



**SSE-F3548S/SSE-F3548SR**

**Link Aggregation**

**User's Guide**

**Revision 1.0**

---

The information in this USER'S GUIDE has been carefully reviewed and is believed to be accurate. The vendor assumes no responsibility for any inaccuracies that may be contained in this document, makes no commitment to update or to keep current the information in this manual, or to notify any person organization of the updates. Please Note: For the most up-to-date version of this manual, please see our web site at [www.supermicro.com](http://www.supermicro.com).

Super Micro Computer, Inc. ("Supermicro") reserves the right to make changes to the product described in this manual at any time and without notice. This product, including software, if any, and documentation may not, in whole or in part, be copied, photocopied, reproduced, translated or reduced to any medium or machine without prior written consent.

DISCLAIMER OF WARRANTY ON SOFTWARE AND MATERIALS. You expressly acknowledge and agree that use of the Software and Materials is at your sole risk. FURTHERMORE, SUPER MICRO COMPUTER INC. DOES NOT WARRANT OR MAKE ANY REPRESENTATIONS REGARDING THE USE OR THE RESULTS OF THE USE OF THE SOFTWARE OR MATERIALS IN TERMS OF THEIR CORRECTNESS, ACCURACY, RELIABILITY, OR OTHERWISE. NO ORAL OR WRITTEN INFORMATION OR ADVICE GIVEN BY SUPER MICRO COMPUTER INC. OR SUPER MICRO COMPUTER INC. AUTHORIZED REPRESENTATIVE SHALL CREATE A WARRANTY OR IN ANY WAY INCREASE THE SCOPE OF THIS WARRANTY. SHOULD THE SOFTWARE AND/OR MATERIALS PROVE DEFECTIVE, YOU (AND NOT SUPER MICRO COMPUTER INC. OR A SUPER MICRO COMPUTER INC. AUTHORIZED REPRESENTATIVE) ASSUME THE ENTIRE COST OF ALL NECESSARY SERVICE, REPAIR, OR CORRECTION.

LIMITATION OF LIABILITY. UNDER NO CIRCUMSTANCES INCLUDING NEGLIGENCE, SHALL SUPER MICRO COMPUTER INC. BE LIABLE FOR ANY INCIDENTAL, SPECIAL, OR CONSEQUENTIAL DAMAGES THAT RESULT FROM THE USE OR INABILITY TO USE THE SOFTWARE OR MATERIALS, EVEN IF SUPER MICRO COMPUTER INC. OR A SUPER MICRO COMPUTER INC. AUTHORIZED REPRESENTATIVE HAS BEEN ADVISED OF THE POSSIBILITY OF SUCH DAMAGES.

Any disputes arising between manufacturer and customer shall be governed by the laws of Santa Clara County in the State of California, USA. The State of California, County of Santa Clara shall be the exclusive venue for the resolution of any such disputes. Super Micro's total liability for all claims will not exceed the price paid for the hardware product.

Manual Revision 1.0  
Release Date: 3/2/2020

Unless you request and receive written permission from Super Micro Computer, Inc., you may not copy any part of this document.

Information in this document is subject to change without notice. Other products and companies referred to herein are trademarks or registered trademarks of their respective companies or mark holders.

Copyright © 2020 by Super Micro Computer, Inc.  
All rights reserved.  
Printed in the United States of America

---

## Document Revision History

Date	Revision	Description
03/2/2020	1.0	Initial document.

---

## Contents

1	Introduction .....	5
2	Link Aggregation Support .....	5
3	Link Aggregation Numbers .....	6
4	Link Aggregation Defaults .....	6
5	Static Link Aggregation.....	6
6	Dynamic Link Aggregation - LACP .....	7
7	Link Aggregation Port Channel .....	8
7.1	Creating Port Channels .....	8
7.1.1	Creating Port Channel Interfaces.....	8
7.1.2	Adding Member Ports to Port Channels.....	9
7.2	Modifying Port Channels .....	11
7.2.1	Modifying Port Channel Parameters .....	11
7.2.2	Modifying Port Channel Member Ports.....	12
7.2.3	Adding New Member Ports .....	12
7.2.4	Removing Member Ports.....	12
7.3	Removing Port Channels.....	15
7.4	LACP Parameters.....	16
7.4.1	LACP System Priority.....	16
7.4.2	LACP Port Priority.....	17
7.4.3	LACP Timeout.....	18
7.4.4	LACP Wait Time.....	21
7.5	Load Balancing .....	22
7.6	Link Aggregation Configuration Example.....	24
	Contacting Supermicro.....	30

---

# 1 Introduction

---

The Link Aggregation feature connects two or more physical links between two network devices without forming loops. Link aggregation can be used between switches, servers and routers.

Link aggregation provides the following advantages:

Increased bandwidth – User can connect up to eight physical links between devices to increase the link bandwidth. When 25 Gbps links are aggregated, users can get an aggregated link with up to 200 Gbps bandwidth. When ports are set to 10Gig speed, users can aggregate eight 10Gig ports to get an aggregated uplink with up to 80 Gbps.

Incremental bandwidth – Users can start aggregation with a fewer number of ports and then increase the number of ports in aggregation (up to eight) incrementally based on the bandwidth requirements.

Redundancy - When one of the physical links fails, traffic will be distributed over the other remaining links in the aggregation.

Figure LA-1: Link Aggregation

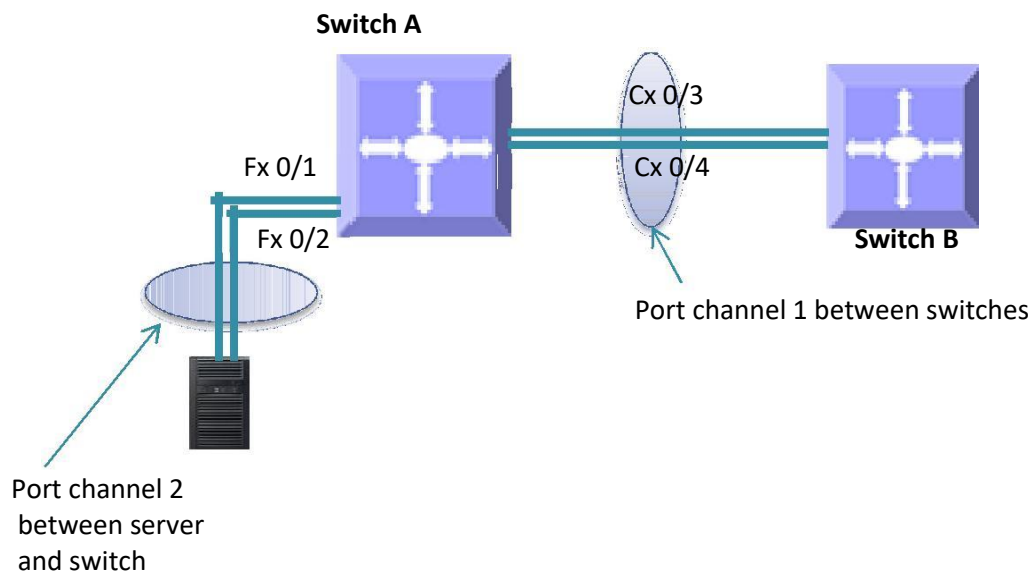

---

 The “port channel”, “channel group” and “ether channels” are used synonymously to refer to aggregate links

---

## 2 Link Aggregation Support

---

Supermicro switches support both static and dynamic link aggregations. Dynamic link aggregation support is based on the Link Aggregation Control Protocol (LACP).

---

Supermicro switches support only Layer 2 level link aggregation. Hence, only switching ports can be aggregated.

Supermicro switches do support the Multiple Chassis Link Aggregation (MLAG) feature.

## 3 Link Aggregation Numbers

---

Supermicro switches support up to 52 port channels.

Each port channel can have eight active links.



Users can configure more than eight ports to a LACP mode port channel. However, a maximum of eight ports only can be in an active bundle state in any port channel.

---

## 4 Link Aggregation Defaults

---

The Link Aggregation feature is enabled by default in Supermicro switches.

When a port channel interface is created, it will be added to VLAN 1 by default.

Port channels use the MAC address of the first physical link added to it.

The default LACP system priority is 32768.

The default LACP port priority is 128.

The default LACP timeout is long (30 seconds).

The default LACP wait time is 2 seconds.

## 5 Static Link Aggregation

---

Supermicro switches support static link aggregation.

User can add up to eight ports to a static port channel group. When the physical link status of one or more ports in a channel group is up, that port channel status will be up. The port channel status will be down when the ports physical link status of all members are down.

Switches do not exchange any port channel control information with other end devices in static link aggregation. Hence, users need to configure the port channel groups and member ports correctly on both end devices.

## 6 Dynamic Link Aggregation – LACP

Superswitches support dynamic link aggregation through IEEE 802.3ad Link Aggregation Control Protocol (LACP).

Users can add one or more ports to an LACP mode port channel. When more than eight member ports are configured, only the first eight member ports reaching the “bundle” state will be used for data traffic.

Ports in LACP mode exchange LACP packets with other end devices. The LACP system priority, switch MAC address, port LACP priority, port number and aggregation key are all exchanged between devices. Based on the exchanged information, both end devices agree on the status of the member ports. The member ports that successfully negotiated LACP parameters will be moved to the “bundle” state. The member ports that could not reach agreement on LACP parameters will stay in the “independent” state. Switches do not send traffic on member ports in “independent” state. When one or more member ports reach the “bundle” state, the port channel status will be up. The port channel status will be down when all its member ports are either physically down or in the “independent” state.

Ports can be configured in either active or passive LACP mode. Ports in active LACP mode will initiate LACP negotiation by sending LACP messages to the other end devices. Ports in passive LACP mode will not initiate the LACP negotiation, but they will respond to LACP messages if received from other end.



Users should configure for an active LACP mode on at least one end of the LACP port channel connection. If LACP mode is configured as passive on both end devices, the port channel interface will not come up. Configuring LACP mode as active on both the end devices is allowed.

Figure LA-2: Dynamic Link Aggregation

Figure LA-2: Dynamic Link Aggregation

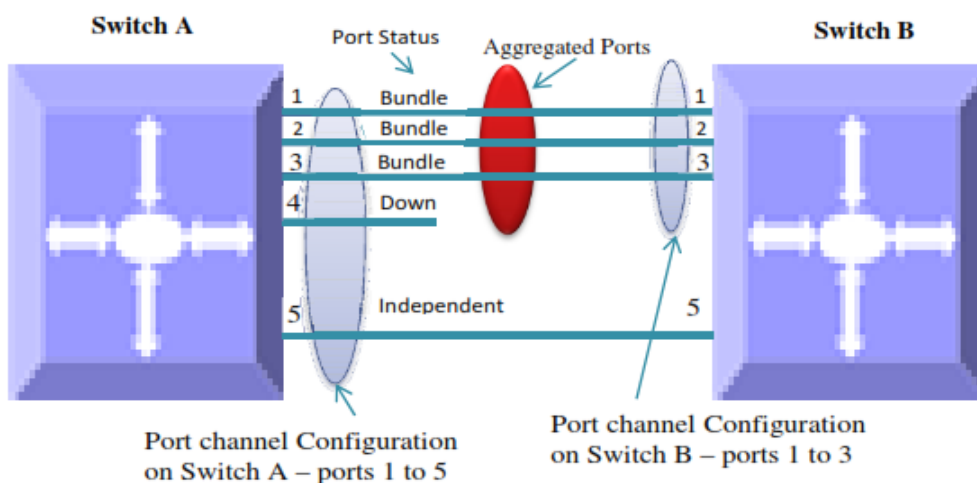

Figure LA-2: Dynamic Link Aggregation

The figure above shows an example of a port channel configuration with port status and aggregated ports. In this example, port 5 is not configured on LACP mode on switch B, and is therefore shown as being in the “independent” state and not part of the aggregated ports.

## 7 Link Aggregation Port Channel

### 7.1 Creating Port Channels

Port channel creation involves two steps: the first is to create the port channel interfaces and the second is to add member ports to the port channel interfaces.

#### 7.1.1 Creating Port Channel Interfaces

Follow the steps below to create port channel interfaces in Supermicro switches.

Step	Command	Description
Step 1	configure terminal	Enters the configuration mode
Step 2	interface port-channel <channel-group-number> Or no interface range port-channel <channel-group-number> ....	Creates a port channel using “interface port—channel” command.  <i>channel-group-number</i> – may be any number from 1 to 65535.  To configure multiple port channel interfaces, use the “interface range ...” command. To provide a range, use a hyphen (-) between the start and end interface numbers. E.g.: int range po 1-3 To provide multiple interfaces or ranges, separate with a comma (.). E.g. : int range po 1, 2
Step 3	description <string>	Optional step - adds any name string to the port channel interfaces using the description command.  The <i>string</i> may be up to 64 characters in length.  The port channel description strings will not affect the member ports



		description strings configurations.
Step 4	<code>mtu &lt;framesize&gt;</code>	Optional step.  Configures the MTU for the port channel interfaces.  <i>framesize</i> may be any number from Port channel MTU will be used on its all member ports.
Step 5	VLAN Configurations	Optional step – configures the VLAN parameters for port channel interfaces.  Refer to the VLAN configuration guide for all VLAN configuration details.
Step 6	Spanning Tree Configurations	Optional step – configures the spanning tree parameters for port channel interfaces.  Refer to the spanning Tree configuration guide for all spanning tree configuration details.
Step 7	End	Exits the configuration mode.
Step 8	<code>show interface port-channel &lt;channel-group-number&gt;</code>  <code>show etherchannel [[channel-group-number] { detail   load-balance   port   port-channel   summary   protocol}]</code>	Displays the configured port channel information.
Step 9	<code>write startup-config</code>	Optional step – saves this port channel configuration to be part of startup configuration.

### 7.1.2 Adding Member Ports to Port Channels

Users can add up to eight member ports to static port channels. For LACP port channels, users can add more than eight ports, but only the first eight member ports reaching a bundle state will be part of the port channel for data transfer.



Only ports of same speed can be added to port channel interfaces.

Follow the steps below to add member ports to port channel interfaces.

Step	Command	Description
Step 1	configure terminal	Enters the configuration mode
Step 2	interface <interface-type><interface-id> Or  interface range <interface-type><interface-id>	Enters the interface mode.  <i>interface-type</i> – may be any of the following: fx-ethernet – fx cx-ethernet – cx  <i>interface-id</i> is in <i>slot/port</i> format for all physical interfaces. To configure multiple interfaces, use the “interface range ...” command. To provide a range, use a hyphen (-) between the start and end interface numbers. E.g.: int range fx 0/1-10 To provide multiple interfaces or ranges, separate with a comma (,). E.g.: int range fx 0/1-10, fx 0/20
Step 3	channel-group <channel-group-number> mode {active   passive   on}	Configures the interfaces as member ports for the given port channel.  <i>channel-group-number</i> – The port channel to which these member ports are added.  For LACP aggregation, use the active or passive mode. For static link aggregation, use mode on.
Step 4	End	Exits the interface configuration mode.
Step 5	show interface port-channel <channel-group-number>  show etherchannel [[channel-group-number] { detail   load-balance   port   port-channel   summary   protocol}]	Displays the configured port channel information.

---

Step 6	write startup-config	Optional step – saves this port channel configuration to be part of startup configuration.
--------	----------------------	--

---



The MTU, VLAN and spanning tree parameters of a port channel interface will be used on its member ports. After adding a port to any port channel, users should not configure MTU, VLAN and spanning tree parameters on that port. Instead users should configure MTU, VLAN and spanning tree parameters on the port channel interfaces.

The examples below show various ways to create port channels.

Create an LACP port channel with member ports cx 0/1 and cx 0/2.

```
SMIS# configure terminal
SMIS(config)# interface port-channel 10
SMIS(config-if)# exit
SMIS(config)# int range cx 0/1-2
SMIS(config-if)# channel-group 10 mode active
SMIS(config-if)# end
```

Create a static port channel having MTU 9000 with member ports cx 0/1 and cx 0/2. Also configure this port channel as a trunk interface to carry all the VLANs configured in the switch.

```
SMIS# configure terminal
SMIS(config)# interface port-channel 10
SMIS(config-if)# mtu 9000
SMIS(config-if)# switchport mode trunk
SMIS(config-if)# exit
SMIS(config)# int range cx 0/1-2
SMIS(config-if)# channel-group 10 mode on
SMIS(config-if)# end
```

## 7.2 Modifying Port Channels

### 7.2.1 Modifying Port Channel Parameters

After a port channel is created, users can modify the port channel configuration for description, MTU, VLAN, and spanning tree parameters. Users should not modify these parameters on port channel member ports directly. Instead, these parameters should be configured on port channel interfaces. To modify port channel parameters, follow the same steps used to create the port channels as explained in the Creating Port Channel Interfaces section.

The example below shows the steps to modify the parameters of a port channel interface.

Modify port channel 10 as a trunk interface to allow VLANs 100 to 200 with a native VLAN 100.

```
SMIS# configure terminal
SMIS(config)# interface port-channel 10
SMIS(config-if)# switchport mode trunk
```

```
SMIS(config-if)# switchport trunk allowed vlan 100-200
SMIS(config-if)# switchport trunk native vlan 100
SMIS(config-if)# exit
```

## 7.2.2 Modifying Port Channel Member Ports

Users can add or remove member ports to the existing port channels. Users can also modify the port modes for member ports.

## 7.2.3 Adding New Member Ports

To add new member ports to an existing port channel, follow the same steps explained in the Adding Member Ports to Port Channels section.

The example below shows the steps necessary to add a new member port to an existing port channel interface.

Add port fx 0/3 to static port channel interface 10.

```
SMIS# configure terminal
SMIS(config)# int fx 0/3
SMIS(config-if)# channel-group 10 mode on
SMIS(config-if)# exit
```

## 7.2.4 Removing Member Ports

Follow the steps below to remove member ports from the port channel interfaces.

Step	Command	Description
Step 1	configure terminal	Enters the configuration mode
Step 2	interface <interface-type><interface-id> Or interface range <interface-type><interface-id> ....	Enters the interface mode.  <i>interface-type</i> – may be any of the following: fx-ethernet – fx cx-ethernet – cx  <i>interface-id</i> is in <i>slot/port</i> format for all physical interfaces.  To configure multiple interfaces, use the “interface range ...” command. To provide a range, use a hyphen (-) between the start and end interface numbers. E.g.: int range fx 0/1-10 To provide multiple interfaces or ranges, separate with a comma (.). E.g.: int range fx 0/1-10, fx 0/20

Step 3	no channel-group	Removes the member ports from the port channel.
Step 4	End	Exits the configuration mode.
Step 5	show interface port-channel <channel-group-number>  show etherchannel [[channel-group-number] { detail   load-balance   port   port-channel   summary   protocol }]	Displays the configured port channel information.
Step 6	write startup-config	Optional step – saves this port channel configuration to be part of startup configuration



When a port is removed from a port channel, that port will automatically be added to VLAN 1. The MTU and spanning tree configurations of that port will not be automatically changed to the default configurations. After removing any port from a port channel, users must verify and change the port VLAN, MTU and spanning tree configurations as needed.

The example below shows the steps necessary to remove a member port from a port channel interface.

Remove port cx 0/3 from port channel interface 10

```
SMIS# configure terminal
```

```
SMIS(config)# int cx 0/3
```

```
SMIS(config-if)# no channel-group
```

```
SMIS(config-if)# exit
```

To modify the port channel mode (active/passive/on) for any member port, users should first remove the port from the port channel using the “no channel-group” command. After removing the port from the port channel interface, the channel-group command can be configured with the required port mode.

Step	Commands	Description
Step 1	configure terminal	Enters the configuration mode
Step 2	interface <interface-type><interface-id> or	Enters the interface mode. Interface-type - may be any of the following:

	<code>interface range &lt;interface-type&gt;&lt;interface-id&gt;....</code>	<p>fx-ethernet – fx cx-ethernet – cx Interface-id is in slot/port format for all physical interfaces. To configure multiple interfaces, use the "interface range..." command. To provide a range, use a hyphen(-) between the start and end interface numbers. E.g.: int range fx0/1-10 To provide multiple interfaces or ranges, separate with a comma(.). E.g.: int range fx 0/1-10,fx 0/1-20</p>
Step 3	<code>no channel-group</code>	Removes the member ports from the port channel.
Step 4	<code>channel-group &lt;channel-group-number&gt; mode {active   passive   on}</code>  <code> </code>	<p>Configures the interfaces as member ports with the given port mode.</p> <p>For LACP aggregation, use the active or passive mode.</p> <p>For static link aggregation, use the mode on.</p> <p><i>channel-group-number</i> – The port channel to which these member ports are added.</p>
Step 5	<code>End</code>	Exits the interface configuration mode.
Step 6	<code>show interface port-channel &lt;channel-group-number&gt;</code>  <code>show etherchannel [[channel-group-number] {detail   load-balance   port   port-channel   summary   protocol}]</code>	Displays the configured port channel information.
Step 7	<code>write startup-config</code>	Optional step – saves this port channel configuration to be part of startup configuration.

The example below shows the steps necessary to modify the member ports modes of a port channel interface.

Modify the member ports' modes to "active" for ports cx 0/2 and cx 0/3.

SMIS# configure terminal

SMIS(config)# int range cx 0/2-3

```
SMIS(config-if)# no channel-group
SMIS(config-if)# channel-group 10 mode active
SMIS(config-if)# exit
```

## 7.3 Removing Port Channels

Step	Command	Description
Step 1	configure terminal	Enters the configuration mode
Step 2	no interface port-channel <channel-group-number> Or no interface range port-channel <channel-group-number> ....	Removes the port channel interface.  <i>channel-group-number</i> – may be any number from 1 to 65535.  To remove multiple port channel interfaces, use the “no interface range ...” command. To provide a range, use a hyphen (-) between the start and end interface numbers. E.g.: no int range po 1-3 To provide multiple interfaces or ranges, separate with a comma (,). E.g. : no int range po 1, 2
Step 3	show running-config  show etherchannel	Displays the port channel information.
Step 4	write startup-config	Optional step – saves this port channel configuration to be part of startup configuration.



When a port channel is removed, all its member ports will be automatically added to VLAN 1. The MTU and spanning tree configurations of that port will not automatically be changed to their default configurations.

The example below shows the necessary steps to remove a port channel interface.

Remove port channel 10 and add all its member ports to VLAN 10 as access ports.

```
SMIS# configure terminal
```

```
SMIS(config)# no int port-channel 10
```

```
SMIS(config)# interface range cx 0/1-2
```

```
SMIS(config-if)# switchport mode access
SMIS(config-if)# switchport access vlan 10
SMIS(config-if)# exit
```

## 7.4 LACP Parameters

Users can configure the following LACP parameters on Supermicro switches.

- LACP System
  - Priority
- LACP Port
  - Priority
- LACP
  - Timeout

### 7.4.1 LACP System Priority

Every LACP device needs to have a globally unique system identifier. This globally unique system identifier is formed by combining a switch’s MAC address and LACP system priority.

LACP system priority is also used to decide the active member ports of a port channel. When more than eight member ports are configured, the switch that has the lowest system priority value decides the active member ports. If both end devices have the same LACP system priority, the device with the numerically lower MAC address will get to decide the active member ports.

The default LACP system priority value is 32768.

Follow the steps below to modify the LACP system priority.

Step	Command	Description
Step 1	configure terminal	Enters the configuration mode.
Step 2	lacp system-priority <system-priority>	Configures the LACP system priority.  <i>system-priority</i> – may be any value from 0 to 65535
Step 3	Exit	Exits the configuration mode.
Step 4	show running-config	Displays the configured LACP system priority value.
Step 5	write startup-config	Optional step – saves this LACP configuration to be part of startup configuration.



The “no lacp system-priority” command resets the LACP system priority to the default value 32768.



The example below shows the steps necessary to configure the LACP system priority value.

Set the LACP system priority as 1000.

SMIS# configure terminal

SMIS(config)# lacp system-priority 1000

SMIS(config-if)# exit

## 7.4.2 LACP Port Priority

If a LACP is configured with more than eight member ports then, switch selects the first eight ports that have the lowest port priority value as active member ports. If multiple ports have the same port priority value then, switch selects the first eight ports that have the numerically lower port ID as the active member ports.

The default LACP port priority is 128.

Follow the steps below to modify the LACP port priority.

Step	Command	Description
Step 1	configure terminal	Enters the configuration mode.
Step 2	interface <interface-type><interface-id> Or interface range <interface-type><interface-id> ....	Enters the interface mode.  <i>interface-type</i> – may be any of the following: fx-ethernet – fx cx-ethernet – cx  <i>interface-id</i> is in <i>slot/port</i> format for all physical interfaces.  To configure multiple interfaces, use the “interface range ...” command. To provide a range, use a hyphen (-) between the start and end interface numbers. E.g.: int range fx 0/1-10 To provide multiple interfaces or ranges, separate with a comma (,). E.g.: int range fx 0/1-10, fx 0/20
Step 3	lacp port-priority <port-priority>	Configures the LACP port priority.  <i>port-priority</i> – may be any value from 0 to 65535
Step 4	End	Exits the configuration mode.
Step 5	show running-config	Displays the configured port priority information.

	show etherchannel	
Step 6	write startup-config	Optional step – saves this port priority configuration to be part of startup configuration.



The “no lacp port-priority” command resets the LACP port priority to the default value of 128.

The example below shows the steps necessary to configure the port priority.

Configure the port priority as 10 for cx 0/1 and 20 for cx 0/2.

SMIS# configure terminal

SMIS(config)# interface cx 0/1

SMIS(config-if)# lacp port-priority 10

SMIS(config-if)# exit

SMIS(config)# interface cx 0/2

SMIS(config-if)# lacp port-priority 20

SMIS(config-if)# exit

### 7.4.3 LACP Timeout

Every LACP member port sends LACP messages periodically. The time period between LACP messages is configurable using the “lacp timeout” command.

Users can define the LACP timeout value either as “long” or “short”. Every member port can have a different LACP timeout selection. Also, the LACP timeout selection does not need to match on both end devices. An LACP port with a “long” timeout can be connected to a port which has a “short” timeout.

When the “long” timeout value is chosen, LACP messages are expected to be received once every 30 seconds. When the “short” timeout value is chosen, LACP messages are expected to be received once every second.

The default LACP timeout is “long”.

Follow the steps below to modify the LACP timeout value.

Step	Command	Description
Step 1	configure terminal	Enters the configuration mode.
Step 2	interface <interface-type><interface-id>	Enters the interface mode.

---

Or

interface range <interface-type><interface-id>

....

lacp timeout {long | short}

Step 3

*interface-type* – may be any of the

following:

fx-ethernet – fx

cx-ethernet – cx

*interface-id* is in *slot/port* format for all physical interfaces.

To configure multiple interfaces, use the “interface range ...” command. To provide a range, use a hyphen (-) between the start and end interface numbers.

E.g.: int range fx 0/1-10

To provide multiple interfaces or ranges, separate with a comma (,).

E.g.: int range fx 0/1-10, fx 0/20

Configures the LACP port timeout.

		<p>long – LACP messages are expected to be received once every 30 seconds.</p> <p>short – LACP messages are expected to be received once every second.</p>
Step 4	End	Exits the configuration mode.
Step 5	<pre>show running-config show etherchannel</pre>	Displays the configured port priority information.
Step 6	write startup-config	Optional step – saves this port timeout configuration to be part of startup configuration.



The “no lacp timeout” command resets the LACP timeout to the default value of “long”.

The example below shows the steps necessary to configure the LACP timeout.

Configure the LACP timeout as short for ports cx 0/1 and cx 0/2.

```
SMIS# configure terminal
```

```
SMIS(config)# interface range cx 0/1-2
```

```
SMIS(config-if)# lacp timeout short
```

```
SMIS(config-if)# exit
```

---

## 7.4.4 LACP Wait Time

Switch waits for the “LACP wait time” period before adding any member port to aggregation.

The default LACP wait time period is two seconds.

Users can choose any time interval from 0 to 10 seconds as the LACP wait time. The LACP wait time is port specific and users can configure different LACP wait times on different member ports.

Follow the steps below to modify the LACP wait time

Step	Command	Description
Step 1	configure terminal	Enters the configuration mode.
Step 2	interface <interface-type><interface-id> Or interface range <interface-type><interface-id> ....	Enters the interface mode.  <i>interface-type</i> – may be any of the following: fx-ethernet – fx cx-ethernet – cx
Step 4	Command	Exits the configuration mode.
Step 5	show running-config show etherchannel	Displays the configured port priority information.
Step 6	write startup-config	Optional step – saves this LACP wait



The “no lacp wait-time” command resets the LACP wait time to the default value of “2”.

---

The example below shows the necessary steps to configure the LACP wait time.

Configure the LACP wait time as 0 for ports cx 0/1 and cx 0/2.

```
SMIS# configure terminal
```

```
SMIS(config)# interface range cx 0/1-2
```

```
SMIS(config-if)# lacp wait-time 0
```

```
SMIS(config-if)# exit
```

---

## 7.5 Load Balancing

Supermicro switches support load balancing on aggregated links.

Switches distribute outgoing traffic on all member ports that are in a bundle state. The distribution decision to transmit a packet on any particular member port is decided by a hash algorithm.

Supermicro switches support the following hash algorithms:

- Packets will be distributed across the member ports based on the source MAC address of the packet.

### Destination MAC Based

- Packets will be distributed across the member ports based on the source and destination MAC addresses of the packet.

### Source based IP

- Packets will be distributed across the member ports based on the source IP address of the packet.

### Destination based IP

- Packets will be distributed across the member ports based on the destination IP address of the packet.

### Source and Destination IP Based

- Packets will be distributed across the member ports based on the source and destination IP addresses of the packet.
- The hash algorithm provides the best distribution when the traffic has multiple streams. Users need to choose the right hash algorithm based on their common traffic scenarios.
- The load balance algorithm selection can be configured for individual port channel interfaces or it can be configured globally for all port channel interfaces. The load balancing algorithm on both ends of a port channel need not be the same.

The default load balancing algorithm is “Source and Destination MAC Based”.

Step	Command	Description
Step 1	configure terminal	Enters the configuration mode.
Step 2	port-channel load-balance {src-mac   dest-mac   src-dest-mac  src-ip   dest-ip   src-dest-ip} [ <channel-group> ]	<i>channel-group</i> is the port channel identifier to which this load balancing algorithm is configured. <i>channel-group</i> number is an optional parameter for this configuration. When

		<i>channel-group</i> is not provided, the given port channel algorithm will be applied to all port channel interfaces.
Step 3	End	Exits the configuration mode.
Step 4	show running-config	Displays the configured load balancing information.
Step 5	write startup-config	Optional step – saves this load balancing configuration to be part of the startup configuration.

Follow the below steps to configure the load balancing algorithm.



The “no port-channel load-balance” command resets the load balancing algorithm to the default value of “src-dest-mac”.

The example below shows the steps necessary to configure the port channel load balancing algorithm. Configure the load balancing algorithm based upon source and destination IP addresses.

SMIS# configure terminal

SMIS(config)# port-channel load-balance src-dest-ip

SMIS(config-if)# exit

The link aggregation feature is enabled by default in Supermicro switches. Users can disable link aggregation if needed.

Follow the steps below to disable the link aggregation feature.

Step	Command	Description
Step 1	configure terminal	Enters the configuration mode.
Step 2	set port-channel disable	Disables the link aggregation feature.
Step 3	End	Exits the configuration mode.
Step 4	show etherchannel	Displays link aggregation feature status.
Step 5	write startup-config	Optional step – saves this configuration to be part of startup configuration.

To enable the link aggregation feature, follow the steps below.

Step	Command	Description
Step 1	configure terminal	Enters the configuration mode.

Step 2	set port-channel enable	Enables the link aggregation feature.
Step 3	End	Exits the configuration mode.
Step 4	show etherchannel	Displays link aggregation feature status
Step 5	write startup-config	Optional step – saves this configuration to be part of startup configuration.

## 7.6 Link Aggregation Configuration Example

Configure switch A as shown below in Figure LA-3.

1. Aggregate ports Cx 0/3 and Cx 0/4 with LACP mode. Also configure this aggregation as a trunk interface with native VLAN 20.
2. Aggregate ports Cx 0/1 and Cx 0/2 with LACP mode. Configure this aggregation as an access port on VLAN 10.
3. Aggregate ports Fx 0/20 and Fx 0/21 statically.

Figure LA-3: Link Aggregation Configuration Example

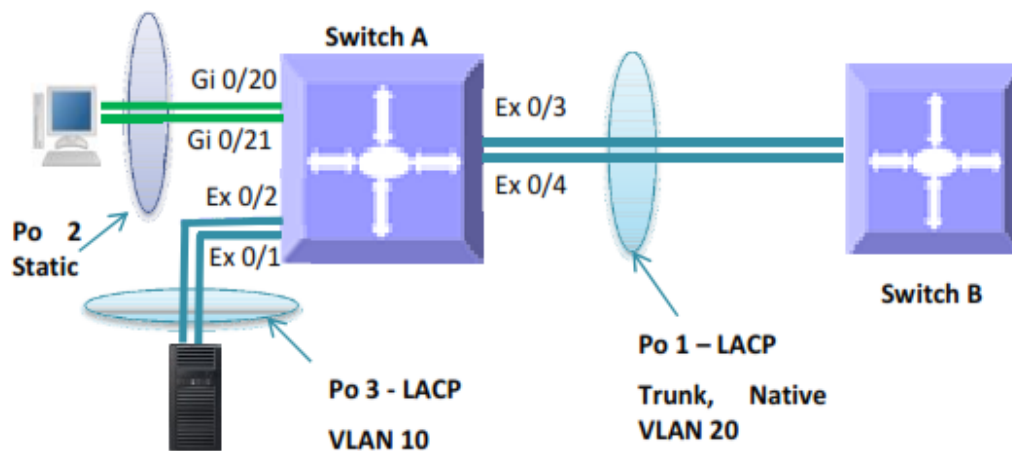

```
SMIS# configure terminal
```

```
# Create all the required VLANs
```

```
first SMIS(config)# vlan 10,20
```

```
SMIS(config-vlan)# exit
```

```
# Create the port channel 1 interface
```

```
SMIS(config)# int port-channel 1
```

```
SMIS(config-if)# exit
```

```
Add member ports to the port channel 1 interface SMIS(config)# int range cx 0/3-4
```

```
SMIS(config-if)# channel-group 1 mode active
```



```

SMIS(config-if)# exit

# Configure the VLAN requirements for the port channel 1 interface
SMIS(config)# int port-channel 1
SMIS(config-if)# switchport mode trunk
SMIS(config-if)# switchport trunk native vlan 20
SMIS(config-if)# exit

# Create the port channel 2 interface
SMIS(config)# int port-channel 2
SMIS(config-if)# exit
# Add member ports to the port channel 2 interface
SMIS(config)# int range fx 0/20-21
SMIS(config-if)# channel-group 2 mode on
SMIS(config-if)# exit

# Create the port channel 3 interface
SMIS(config)# int port-channel 3
SMIS(config-if)# exit

# Add member ports to the port channel 3 interface
SMIS(config)# int range cx 0/1-2
SMIS(config-if)# channel-group 3 mode active
SMIS(config-if)# exit
# Configure the VLAN requirements for the port channel 3 interface
SMIS(config)# int port-channel 3
SMIS(config-if)# switchport mode access
SMIS(config-if)# switchport access vlan 10
SMIS(config-if)# end
# Check the running-configuration for accuracy
SMIS# show running-config
Building configuration...
ID          ID Hardware VersionID  Hardware Version
Hardwar    Firmware  OS      Firmware  OS      Boot
e Version  Boot Loader      Loader
Firmware
OS
Boot
Loader
0          0      SSE-F3548      0      SSE-
SSE-      1.0.0.0 6      0.0.0.0  F3548
F3548      1.0.0.0 6
1.0.0.0      0.0.0.0
6
0.0.0.0
ip address dhcp interface port-channel 1 exit
interface port-channel 2 exit

```

---

```
interface port-channel 3 exit
vlan 1

ports fx 0/1-19 untagged ports fx 0/22-48 untagged ports po 2 untagged
exit vlan 10
ports po 3 untagged exit
vlan 20
ports po 1 untagged
exit
```

```
interface Fx 0/20 channel-group 2 mode on
interface Fx 0/21 channel-group 2 mode on
interface Cx 0/1 channel-group 3 mode active
interface Cx 0/2 channel-group 3 mode active
interface Cx 0/3 channel-group 1 mode active
interface Cx 0/4 channel-group 1 mode active
interface po 1
switchport trunk native vlan 20
switchport mode trunk
interface po 3
switchport access vlan 10
switchport mode access
exit
```

```
SMIS#
# Check the port channels using the "show etherchannel" command
SMIS# show etherchannel detail
Port-channel Module Admin Status is enabled
Port-channel Module Oper Status is enabled
Port-channel System Identifier is 00:30:48:a1:11:01
LACP System Priority: 32768
Channel Group Listing
```

```
-----
Group: 1
Protocol: LACP
Ports in the Group
-----
Port: Cx0/3
-----
Port State = Down, Not in Bundle
Channel Group: 1
Mode: Active
Pseudo port-channel = Po1
LACP port-priority = 128
LACP Wait-time = 2 secs
LACP Activity: Active
```

---

LACP Timeout: Long  
Aggregation State: Aggregation, Defaulted  
Port: Cx0/4

-----  
Port State = Down, Not in Bundle  
Channel Group: 1  
Mode: Active  
Pseudo port-channel = Po1  
LACP port-priority = 128  
LACP Wait-time = 2 secs  
LACP Activity: Active  
LACP Timeout: Long  
Aggregation State: Aggregation, Defaulted

LACP Port Admin Oper Port Port Port State Priority Key Key Number State

-----  
Cx0/3 Down 128 1 1 0x33 0x45  
Cx0/4 Down 128 1 1 0x34 0x45

Port-channel: Po1

-----  
Number of Ports = 2 HotStandBy port = null  
Port state = Port-channel Ag-Not-Inuse Protocol = LACP  
Default Port = None  
Channel Group Listing

-----  
Group: 2

-----  
Protocol: Manual  
Ports in the Group

-----  
Port: Fx0/20

-----  
Port State = Down, Not in Bundle  
Channel Group: 2  
Mode: On  
Pseudo port-channel = Po2  
LACP port-priority = 128  
LACP Wait-time = 2 secs  
LACP Activity: Passive  
LACP Timeout: Long  
Aggregation State: Aggregation, Defaulted  
Port: Fx0/21

-----  
Port State = Down, Not in Bundle  
Channel Group: 2  
Mode: On

---

Pseudo port-channel = Po2  
 LACP port-priority = 128  
 LACP Wait-time = 2 secs  
 LACP Activity: Passive  
 LACP Timeout: Long  
 Aggregation State: Aggregation, Defaulted  
 LACP Port Admin Oper Port Port Port State Priority Key Key Number State

-----  
 Fx0/20 Down 128 2 2 0x14 0x44  
 Fx0/21 Down 128 2 2 0x15 0x44

Port-channel: Po2  
 -----

Number of Ports = 2  
 HotStandBy port = null  
 Port state = Port-channel Ag-Not-Inuse  
 Protocol = Manual  
 Default Port = None  
 Channel Group Listing

-----  
 Group: 3  
 -----

Protocol: LACP  
 Ports in the Group

-----  
 Port: Fx0/1  
 -----

Port State = Down, Not in Bundle  
 Channel Group: 3  
 Mode: Active  
 Pseudo port-channel = Po3  
 LACP port-priority = 128  
 LACP Wait-time = 2 secs  
 LACP Activity: Active  
 LACP Timeout: Long  
 Aggregation State: Aggregation, Defaulted  
 Port: Fx0/2  
 -----

Port State = Down, Not in Bundle  
 Channel Group: 3  
 Mode: Active  
 Pseudo port-channel = Po3  
 LACP port-priority = 128  
 LACP Wait-time = 2 secs  
 LACP Activity: Active  
 LACP Timeout: Long  
 Aggregation State: Aggregation, Defaulted  
 LACP Port Admin Oper Port Port Port State Priority Key Key Number State

---

-----  
Fx0/1 Down 128 3 3 0x31 0x45

Fx0/2 Down 128 3 3 0x32 0x45

Port-channel: Po3  
-----

Number of Ports = 2

HotStandBy port = null

Port state = Port-channel Ag-Not-Inuse

Protocol = LACP

Default Port = None

SMIS#

# Save this port channel configuration. SMIS# write startup-config

Building configuration, please wait. May take a few minutes . . .

[OK]

SMIS#

---

# Contacting Supermicro

---

## Headquarters

Address: Super Micro Computer, Inc.  
980 Rock Ave.  
San Jose, CA 95131 U.S.A.  
Tel: +1 (408) 503-8000  
Fax: +1 (408) 503-8008  
Email: [marketing@supermicro.com](mailto:marketing@supermicro.com) (General Information)  
[support@supermicro.com](mailto:support@supermicro.com) (Technical Support)  
Web Site: [www.supermicro.com](http://www.supermicro.com)

## Europe

Address: Super Micro Computer B.V.  
Het Sterrenbeeld 28, 5215 ML  
's-Hertogenbosch, The Netherlands  
Tel: +31 (0) 73-6400390  
Fax: +31 (0) 73-6416525  
Email: [sales@supermicro.nl](mailto:sales@supermicro.nl) (General Information)  
[support@supermicro.nl](mailto:support@supermicro.nl) (Technical Support)  
[rma@supermicro.nl](mailto:rma@supermicro.nl) (Customer Support)  
Web Site: [www.supermicro.com.nl](http://www.supermicro.com.nl)

## Asia-Pacific

Address: Super Micro Computer, Inc.  
3F, No. 150, Jian 1st Rd.  
Zhonghe Dist., New Taipei City 235  
Taiwan (R.O.C)  
Tel: +886-(2) 8226-3990  
Fax: +886-(2) 8226-3992  
Email: [support@supermicro.com.tw](mailto:support@supermicro.com.tw)  
Web Site: [www.supermicro.com.tw](http://www.supermicro.com.tw)