

SUPER

SC213L Chassis Series

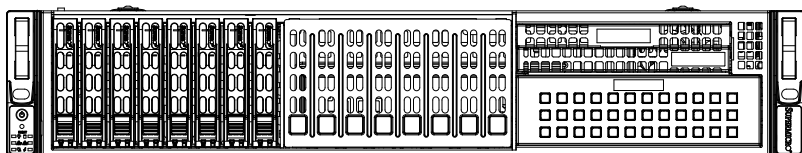

SC213LT-600LPB

SC213LT-563LPB

SC213LT-563UB

SC213LTQ-R720LPB

SC213LTQ-R720UB

USER'S MANUAL

1.0b

The information in this User's Manual has been carefully reviewed and is believed to be accurate. The vendor assumes no responsibility for any inaccuracies that may be contained in this document, makes no commitment to update or to keep current the information in this manual, or to notify any person or organization of the updates. **Please Note: For the most up-to-date version of this manual, please see our web site at www.supermicro.com.**

Super Micro Computer, Inc. ("Supermicro") reserves the right to make changes to the product described in this manual at any time and without notice. This product, including software and documentation, is the property of Supermicro and/or its licensors, and is supplied only under a license. Any use or reproduction of this product is not allowed, except as expressly permitted by the terms of said license.

IN NO EVENT WILL SUPERMICRO BE LIABLE FOR DIRECT, INDIRECT, SPECIAL, INCIDENTAL, SPECULATIVE OR CONSEQUENTIAL DAMAGES ARISING FROM THE USE OR INABILITY TO USE THIS PRODUCT OR DOCUMENTATION, EVEN IF ADVISED OF THE POSSIBILITY OF SUCH DAMAGES. IN PARTICULAR, SUPERMICRO SHALL NOT HAVE LIABILITY FOR ANY HARDWARE, SOFTWARE, OR DATA STORED OR USED WITH THE PRODUCT, INCLUDING THE COSTS OF REPAIRING, REPLACING, INTEGRATING, INSTALLING OR RECOVERING SUCH HARDWARE, SOFTWARE, OR DATA.

Any disputes arising between manufacturer and customer shall be governed by the laws of Santa Clara County in the State of California, USA. The State of California, County of Santa Clara shall be the exclusive venue for the resolution of any such disputes. Super Micro's total liability for all claims will not exceed the price paid for the hardware product.

California Best Management Practices Regulations for Perchlorate Materials: This Perchlorate warning applies only to products containing CR (Manganese Dioxide) Lithium coin cells. "Perchlorate Material-special handling may apply. See www.dtsc.ca.gov/hazardouswaste/perchlorate"

WARNING: Handling of lead solder materials used in this product may expose you to lead, a chemical known to the State of California to cause birth defects and other reproductive harm.

Manual Revision 1.0b
Release Date: March 4, 2014

Unless you request and receive written permission from Super Micro Computer, Inc., you may not copy any part of this document.

Information in this document is subject to change without notice. Other products and companies referred to herein are trademarks or registered trademarks of their respective companies or mark holders.

Copyright © 2014 by Super Micro Computer, Inc.
All rights reserved.

Printed in the United States of America

Preface

About This Manual

This manual is written for professional system integrators and PC technicians. It provides information for the installation and use of the chassis. Installation and maintenance should be performed by experienced technicians only.

This document lists compatible parts available when this document was published. Refer to the Supermicor web site for updates on supported parts and configurations.

Manual Organization

Chapter 1 Introduction

The first chapter describes product features and Supermicro contact information.

Chapter 2 Warning Statements for AC Systems

This chapter lists warnings, precautions, and system safety. It is recommended that you thoroughly familiarize yourself with these before installing or servicing this product.

Chapter 3 Chassis Components

This chapter lists components such as drive bays, power supplies, and the cooling system.

Chapter 4 System Interface

This chapter describes control panel buttons and status indicator lights.

Chapter 5 Chassis Setup and Installation

Follow the procedures given in this chapter when installing, removing, or reconfiguring your chassis.

Chapter 6 Rack Installation

Refer to this chapter for rack installation.

Appendix A Cables, Screws and other Accessories

Appendix B Power Supply Specifications

Appendix C and D Backplane Specs

Contents

Chapter 1 Introduction

1-1	Overview	1-1
1-2	Contacting Supermicro.....	1-2
1-3	Returning Merchandise for Service.....	1-3

Chapter 2 Standardized Warning Statements for AC Systems

2-1	About Standardized Warning Statements.....	2-1
	Warning Definition	2-1
	Installation Instructions.....	2-4
	Circuit Breaker	2-5
	Power Disconnection Warning	2-6
	Equipment Installation.....	2-8
	Restricted Area.....	2-9
	Battery Handling.....	2-10
	Redundant Power Supplies	2-12
	Backplane Voltage	2-13
	Comply with Local and National Electrical Codes	2-14
	Product Disposal	2-15
	Hot Swap Fan Warning.....	2-16
	Power Cable and AC Adapter	2-18

Chapter 3 Chassis Components

3-1	Overview	3-1
3-2	Components.....	3-1
	Drives	3-1
	Motherboard.....	3-1
	Backplane.....	3-1
	Expansion Cards.....	3-1
	Power Supply.....	3-2
	Fans	3-2
	Mounting Rails	3-2
3-3	Where to get Replacement Components.....	3-2

Chapter 4 System Interface

4-1	Overview	4-1
4-2	Control Panel Buttons	4-2
4-3	Control Panel LEDs	4-2
	Overheating.....	4-3

4-4	Drive Carrier LEDs	4-4
4-5	Power Supply LEDs	4-4

Chapter 5 Chassis Setup and Maintenance

5-1	Overview	5-1
5-2	Removing Power from the System	5-1
5-3	Removing the Chassis Cover	5-2
5-4	Installing Hard Drives	5-3
5-5	Installing the Motherboard	5-5
	I/O Shield	5-5
	Permanent and Optional Standoffs	5-6
	Installation Procedure	5-6
5-6	Installing Expansion Cards	5-8
	Expansion Cards for a U Model Chassis	5-8
5-7	Installing the Air Shroud	5-11
	Checking the Air Flow	5-12
	Installation Complete	5-12
5-8	System Fans	5-12
5-9	Power Supply	5-14
	Single Unit	5-14
	Redundant Units	5-14
	Installing the Power Distributor	5-15
5-10	Backplane	5-16

Chapter 6 Rack Installation

6-1	Unpacking the System	6-1
6-2	Preparing for Setup	6-1
	Choosing a Setup Location	6-1
6-3	Warnings and Precautions	6-2
	Rack Precautions	6-2
	General Server Precautions	6-2
	Rack Mounting Considerations	6-3
	Ambient Operating Temperature	6-3
	Sufficient Airflow	6-3
	Circuit Overloading	6-3
	Reliable Ground	6-3
6-4	Installing the System into a Rack	6-4
	Identifying the Sections of the Rack Rails	6-4
	Releasing the Inner Rail	6-5
	Installing the Inner Rails on the Chassis	6-6

Installing the Outer Rails onto the Rack.....	6-7
Sliding the Chassis onto the Rack Rails.....	6-8

Appendix A SC213L Chassis Cables

Appendix B SC213L Power Supply Specifications

Appendix C BPN-SAS-213LTQ Backplane Specifications

Appendix D BPN-SAS-213LT Backplane Specifications

Notes

Chapter 1

Introduction

1-1 Overview

Supermicro's SC213L chassis provides eight hot-swappable 2.5" SAS/SATA hard drive bays and one 5.25" hard drive in an efficient 2U form factor, designed for the most frequently encountered applications. The chassis is also equipped with a high-efficiency power supply for outstanding power savings, with specially designed optimized cooling.

Note: A complete list of safety warnings is provided on the Supermicro web site at http://www.supermicro.com/about/policies/safety_information.cfm.

SC213L			
Model	HDD	I/O Slots	Power Supply
SC213LTQ-R720LPB	8x 2.5" hot-swap SAS/SATA	7x LP	720W Redundant (Gold Level)
SC213LTQ-R720UB	8x 2.5" hot-swap SAS/SATA	4x FH and 3x LP	720W Redundant (Gold Level)
SC213LT-600LPB	8x 2.5" hot-swap SAS/SATA	7x LP	600W
SC213LT-563LPB	8x 2.5" hot-swap SAS/SATA	7x LP	560W (Gold Level)
SC213LT-563UB	8x 2.5" hot-swap SAS/SATA	4x FH, 3x LP, 1x FH UIO	560W (Gold Level)

FH = Full-height, Half-length

LP = Low-profile

1-2 Contacting Supermicro

Headquarters

Address: Super Micro Computer, Inc.
980 Rock Ave.
San Jose, CA 95131 U.S.A.

Tel: +1 (408) 503-8000

Fax: +1 (408) 503-8008

Email: marketing@supermicro.com (General Information)
support@supermicro.com (Technical Support)

Web Site: www.supermicro.com

Europe

Address: Super Micro Computer B.V.
Het Sterrenbeeld 28, 5215 ML
's-Hertogenbosch, The Netherlands

Tel: +31 (0) 73-6400390

Fax: +31 (0) 73-6416525

Email: sales@supermicro.nl (General Information)
support@supermicro.nl (Technical Support)
rma@supermicro.nl (Customer Support)

Web Site: www.supermicro.com

Asia-Pacific

Address: Super Micro Computer, Inc.
3F, No. 150, Jian 1st Rd.
Zhonghe Dist., New Taipei City 235
Taiwan (R.O.C)

Tel: +886-(2) 8226-3990

Fax: +886-(2) 8226-3992

Email: support@supermicro.com.tw

Tel: +886-(2)-8226-3990

Web Site: www.supermicro.com.tw

1-3 Returning Merchandise for Service

A receipt or copy of your invoice marked with the date of purchase is required before any warranty service will be rendered. You can obtain service by calling your vendor for a Returned Merchandise Authorization (RMA) number. When returning to the manufacturer, the RMA number should be prominently displayed on the outside of the shipping carton, and mailed prepaid or hand-carried. Shipping and handling charges will be applied for all orders that must be mailed when service is complete.

For faster service, RMA authorizations may be requested online (<http://www.supermicro.com/support/rma/>).

Whenever possible, repack the chassis in the original Supermicro carton, using the original packaging material. If these are no longer available, be sure to pack the chassis securely, using packaging material to surround the chassis so that it does not shift within the carton and become damaged during shipping.

This warranty only covers normal consumer use and does not cover damages incurred in shipping or from failure due to the alteration, misuse, abuse or improper maintenance of products.

During the warranty period, contact your distributor first for any product problems.

Notes

Chapter 2

Standardized Warning Statements for AC Systems

2-1 About Standardized Warning Statements

The following statements are industry standard warnings, provided to warn the user of situations which have the potential for bodily injury. Should you have questions or experience difficulty, contact Supermicro's Technical Support department for assistance. Only certified technicians should attempt to install or configure components.

Read this appendix in its entirety before installing or configuring components in the Supermicro chassis.

These warnings may also be found on our web site at http://www.supermicro.com/about/policies/safety_information.cfm.

Warning Definition



Warning!

This warning symbol means danger. You are in a situation that could cause bodily injury. Before you work on any equipment, be aware of the hazards involved with electrical circuitry and be familiar with standard practices for preventing accidents.

警告の定義

この警告サインは危険を意味します。

人身事故につながる可能性がありますので、いずれの機器でも動作させる前に、電気回路に含まれる危険性に注意して、標準的な事故防止策に精通して下さい。

此警告符号代表危險。

您正处于可能受到严重伤害的工作环境中。在您使用设备开始工作之前，必须充分意识到触电的危险，并熟练掌握防止事故发生的标准工作程序。请根据每项警告结尾的声明号码找到此设备的安全性警告说明的翻译文本。

此警告符號代表危險。

您正處於可能身體可能會受損傷的工作環境中。在您使用任何設備之前，請注意觸電的危險，並且要熟悉預防事故發生的標準工作程序。請依照每一注意事項後的號碼找到相關的翻譯說明內容。

Warnung

WICHTIGE SICHERHEITSHINWEISE

Dieses Warnsymbol bedeutet Gefahr. Sie befinden sich in einer Situation, die zu Verletzungen führen kann. Machen Sie sich vor der Arbeit mit Geräten mit den Gefahren elektrischer Schaltungen und den üblichen Verfahren zur Vorbeugung vor Unfällen vertraut. Suchen Sie mit der am Ende jeder Warnung angegebenen Anweisungsnummer nach der jeweiligen Übersetzung in den übersetzten Sicherheitshinweisen, die zusammen mit diesem Gerät ausgeliefert wurden.

BEWAHREN SIE DIESE HINWEISE GUT AUF.

INSTRUCCIONES IMPORTANTES DE SEGURIDAD

Este símbolo de aviso indica peligro. Existe riesgo para su integridad física. Antes de manipular cualquier equipo, considere los riesgos de la corriente eléctrica y familiarícese con los procedimientos estándar de prevención de accidentes. Al final de cada advertencia encontrará el número que le ayudará a encontrar el texto traducido en el apartado de traducciones que acompaña a este dispositivo.

GUARDE ESTAS INSTRUCCIONES.

IMPORTANTES INFORMATIONS DE SÉCURITÉ

Ce symbole d'avertissement indique un danger. Vous vous trouvez dans une situation pouvant entraîner des blessures ou des dommages corporels. Avant de travailler sur un équipement, soyez conscient des dangers liés aux circuits électriques et familiarisez-vous avec les procédures couramment utilisées pour éviter les accidents. Pour prendre connaissance des traductions des avertissements figurant dans les consignes de sécurité traduites qui accompagnent cet appareil, référez-vous au numéro de l'instruction situé à la fin de chaque avertissement.

CONSERVEZ CES INFORMATIONS.

תקנת הצהרות אזהרה

הצהרות הבאות הן אזהרות על פי תקני התעשייה, על מנת להזהיר את המשתמש מפני חבלה פיזית אפשרית. במידה ויש שאלות או היתקלות בבעיה כלשהי, יש ליצור קשר עם מחלקת תמיכה טכנית של סופרמיקרו. טכנאים מוסמכים בלבד רשאים להתקין או להגדיר את הרכיבים.

יש לקרוא את הנספח במלוואו לפני התקנת או הגדרת הרכיבים במארוזי סופרמיקרו.

تحذير! هذا الرمز يعني خطر انك في حالة يمكن أن تتسبب في اصابة جسدية .
قبل أن تعمل على أي معدات، كن على علم بالمخاطر الناجمة عن الدوائر
الكهربائية
وكن على دراية بالممارسات الوقائية لمنع وقوع أي حوادث
استخدم رقم البيان المنصوص في نهاية كل تحذير للعثور ترجمتها

안전을 위한 주의사항

경고!

이 경고 기호는 위험이 있음을 알려 줍니다. 작업자의 신체에 부상을 야기 할 수 있는 상태에 있게 됩니다. 모든 장비에 대한 작업을 수행하기 전에 전기회로와 관련된 위험요소들을 확인하시고 사전에 사고를 방지할 수 있도록 표준 작업절차를 준수해 주시기 바랍니다.

해당 번역문을 찾기 위해 각 경고의 마지막 부분에 제공된 경고문 번호를 참조하십시오

BELANGRIJKE VEILIGHEIDSINSTRUCTIES

Dit waarschuwings symbool betekent gevaar. U verkeert in een situatie die lichamelijk letsel kan veroorzaken. Voordat u aan enige apparatuur gaat werken, dient u zich bewust te zijn van de bij een elektrische installatie betrokken risico's en dient u op de hoogte te zijn van de standaard procedures om ongelukken te voorkomen. Gebruik de nummers aan het eind van elke waarschuwing om deze te herleiden naar de desbetreffende locatie.

BEWAAR DEZE INSTRUCTIES

Installation Instructions



Warning!

Read the installation instructions before connecting the system to the power source.

設置手順書

システムを電源に接続する前に、設置手順書をお読み下さい。

警告

将此系统连接电源前，请先阅读安装说明。

警告

將系統與電源連接前，請先閱讀安裝說明。

Warnung

Vor dem Anschließen des Systems an die Stromquelle die Installationsanweisungen lesen.

¡Advertencia!

Lea las instrucciones de instalación antes de conectar el sistema a la red de alimentación.

Attention

Avant de brancher le système sur la source d'alimentation, consulter les directives d'installation.

יש לקרוא את הוראות התקנה לפני חיבור המערכת למקור מתח.

اقرأ إرشادات التركيب قبل توصيل النظام إلى مصدر للطاقة

시스템을 전원에 연결하기 전에 설치 안내를 읽어주시시오.

Waarschuwing

Raadpleeg de installatie-instructies voordat u het systeem op de voedingsbron aansluit.

Circuit Breaker



Warning!

This product relies on the building's installation for short-circuit (overcurrent) protection. Ensure that the protective device is rated not greater than: 250 V, 20 A.

サーキット・ブレーカー

この製品は、短絡(過電流)保護装置がある建物での設置を前提としています。

保護装置の定格が250 V、20 Aを超えないことを確認下さい。

警告

此产品的短路(过载电流)保护由建筑物的供电系统提供,确保短路保护设备的额定电流不大于250V,20A。

警告

此产品的短路(過載電流)保護由建築物的供電系統提供,確保短路保護設備的額定電流不大於250V,20A。

Warnung

Dieses Produkt ist darauf angewiesen, dass im Gebäude ein Kurzschluss- bzw. Überstromschutz installiert ist. Stellen Sie sicher, dass der Nennwert der Schutzvorrichtung nicht mehr als: 250 V, 20 A beträgt.

¡Advertencia!

Este equipo utiliza el sistema de protección contra cortocircuitos (o sobrecorrientes) del edificio. Asegúrese de que el dispositivo de protección no sea superior a: 250 V, 20 A.

Attention

Pour ce qui est de la protection contre les courts-circuits (surtension), ce produit dépend de l'installation électrique du local. Vérifiez que le courant nominal du dispositif de protection n'est pas supérieur à :250 V, 20 A.

מוצר זה מסתמך על הגנה המותקנת במבנים למניעת קצר חשמלי. יש לוודא כי המכשיר המגן מפני הקצר החשמלי הוא לא יותר מ-250 V, 20 A

هذا المنتج يعتمد على معدات الحماية من الدوائر القصيرة التي تم تثبيتها في المبنى

تأكد من أن تقييم الجهاز الوقائي ليس أكثر من: 20A, 250V

경고!

이 제품은 전원의 단락(과전류)방지에 대해서 전적으로 건물의 관련 설비에 의존합니다. 보호장치의 정격이 반드시 250V(볼트), 20A(암페어)를 초과하지 않도록 해야 합니다.

Waarschuwing

Dit product is afhankelijk van de kortsluitbeveiliging (overspanning) van uw elektrische installatie. Controleer of het beveiligde apparaat niet groter gedimensioneerd is dan 220V, 20A.

Power Disconnection Warning



Warning!

The system must be disconnected from all sources of power and the power cord removed from the power supply module(s) before accessing the chassis interior to install or remove system components.

電源切斷の警告

システムコンポーネントの取り付けまたは取り外しのために、シャーシ内部にアクセスするには、システムの電源はすべてのソースから切斷され、電源コードは電源モジュールから取り外す必要があります。

警告

在你打开机箱并安装或移除内部器件前，必须将系统完全断电，并移除电源线。

警告

在您打開機殼安裝或移除內部元件前，必須將系統完全斷電，並移除電源線。

Warnung

Das System muss von allen Quellen der Energie und vom Netzanschlusskabel getrennt sein, das von den Spg.Versorgungsteilmodulen entfernt wird, bevor es auf den Chassisinnenraum zurückgreift, um Systemsbestandteile anzubringen oder zu entfernen.

¡Advertencia!

El sistema debe ser disconnected de todas las fuentes de energía y del cable eléctrico quitado de los módulos de fuente de alimentación antes de tener acceso el interior del chasis para instalar o para quitar componentes de sistema.

Attention

Le système doit être débranché de toutes les sources de puissance ainsi que de son cordon d'alimentation secteur avant d'accéder à l'intérieur du châssis pour installer ou enlever des composants de système.

אזהרה!

יש לנתק את המערכת מכל מקורות החשמל ויש להסיר את כבל החשמלי מהספק לפני גישה לחלק הפנימי של המארז לצורך התקנת או הסרת רכיבים.

يجب فصل النظام من جميع مصادر الطاقة وإزالة سلك الكهرباء من وحدة امداد الطاقة قبل الوصول إلى المناطق الداخلية للهيكल لتثبيت أو إزالة مكونات الجهاز

경고!

시스템에 부품들을 장착하거나 제거하기 위해서는 새시 내부에 접근하기 전에 반드시 전원 공급장치로부터 연결되어있는 모든 전원과 전기코드를 분리해주어야 합니다.

Waarschuwing

Voordat u toegang neemt tot het binnenwerk van de behuizing voor het installeren of verwijderen van systeem onderdelen, dient u alle spanningsbronnen en alle stroomkabels aangesloten op de voeding(en) van de behuizing te verwijderen

Equipment Installation



Warning!

Only trained and qualified personnel should be allowed to install, replace, or service this equipment.

機器の設置

トレーニングを受け認定された人だけがこの装置の設置、交換、またはサービスを許可されています。

警告

只有经过培训且具有资格的人员才能进行此设备的安装、更换和维修。

警告

只有經過受訓且具資格人員才可安裝、更換與維修此設備。

Warnung

Das Installieren, Ersetzen oder Bedienen dieser Ausrüstung sollte nur geschultem, qualifiziertem Personal gestattet werden.

¡Advertencia!

Solamente el personal calificado debe instalar, reemplazar o utilizar este equipo.

Attention

Il est vivement recommandé de confier l'installation, le remplacement et la maintenance de ces équipements à des personnels qualifiés et expérimentés.

אזהרה!

צוות מוסמך בלבד רשאי להתקין, להחליף את הציוד או לתת שירות עבור הציוד.

يجب أن يسمح فقط للموظفين المؤهلين والمدربين لتثبيت واستبدال أو خدمة هذا الجهاز

경고!

훈련을 받고 공인된 기술자만이 이 장비의 설치, 교체 또는 서비스를 수행할 수 있습니다.

Waarschuwing

Deze apparatuur mag alleen worden geïnstalleerd, vervangen of hersteld door geschoold en gekwalificeerd personeel.

Restricted Area



Warning!

This unit is intended for installation in restricted access areas. A restricted access area can be accessed only through the use of a special tool, lock and key, or other means of security. (This warning does not apply to workstations).

アクセス制限区域

このユニットは、アクセス制限区域に設置されることを想定しています。

アクセス制限区域は、特別なツール、鍵と錠前、その他のセキュリティの手段を用いてのみ出入りが可能です。

警告

此部件应安装在限制进出的场所，限制进出的场所指只能通过使用特殊工具、锁和钥匙或其它安全手段进出的场所。

警告

此裝置僅限安裝於進出管制區域，進出管制區域係指僅能以特殊工具、鎖頭及鑰匙或其他安全方式才能進入的區域。

Warnung

Diese Einheit ist zur Installation in Bereichen mit beschränktem Zutritt vorgesehen. Der Zutritt zu derartigen Bereichen ist nur mit einem Spezialwerkzeug, Schloss und Schlüssel oder einer sonstigen Sicherheitsvorkehrung möglich.

¡Advertencia!

Esta unidad ha sido diseñada para instalación en áreas de acceso restringido. Sólo puede obtenerse acceso a una de estas áreas mediante la utilización de una herramienta especial, cerradura con llave u otro medio de seguridad.

Attention

Cet appareil doit être installée dans des zones d'accès réservés. L'accès à une zone d'accès réservé n'est possible qu'en utilisant un outil spécial, un mécanisme de verrouillage et une clé, ou tout autre moyen de sécurité.

אזור עם גישה מוגבלת

אזהרה!

יש להתקין את היחידה באזורים שיש בהם הגבלת גישה. הגישה ניתנת בעזרת כלי אבטחה בלבד (מפתח, מנעול וכד').

تم تخصيص هذه الوحدة لت تركيبها في مناطق محظورة .
يمكن الوصول إلى منطقة محظورة فقط من خلال استخدام أداة خاصة،
قفل ومفتاح أو أي وسيلة أخرى للأمان

경고!

이 장치는 접근이 제한된 구역에 설치하도록 되어 있습니다. 특수도구, 잠금 장치 및 키, 또는 기타 보안 수단을 통해서만 접근 제한 구역에 들어갈 수 있습니다.

Waarschuwing

Dit apparaat is bedoeld voor installatie in gebieden met een beperkte toegang. Toegang tot dergelijke gebieden kunnen alleen verkregen worden door gebruik te maken van speciaal gereedschap, slot en sleutel of andere veiligheidsmaatregelen.

Battery Handling



Warning!

There is the danger of explosion if the battery is replaced incorrectly. Replace the battery only with the same or equivalent type recommended by the manufacturer. Dispose of used batteries according to the manufacturer's instructions

電池の取り扱い

電池交換が正しく行われなかった場合、破裂の危険性があります。交換する電池はメーカーが推奨する型、または同等のものを使用下さい。使用済電池は製造元の指示に従って処分して下さい。

警告

電池更換不當會有爆炸危險。請只使用同類電池或製造商推薦的功能相當的電池更換原有電池。請按製造商的說明處理廢舊電池。

警告

電池更換不當會有爆炸危險。請使用製造商建議之相同或功能相當的電池更換原有電池。請按照製造商的說明指示處理廢棄舊電池。

Warnung

Bei Einsetzen einer falschen Batterie besteht Explosionsgefahr. Ersetzen Sie die Batterie nur durch den gleichen oder vom Hersteller empfohlenen Batterietyp. Entsorgen Sie die benutzten Batterien nach den Anweisungen des Herstellers.

Attention

Danger d'explosion si la pile n'est pas remplacée correctement. Ne la remplacer que par une pile de type semblable ou équivalent, recommandée par le fabricant. Jeter les piles usagées conformément aux instructions du fabricant.

¡Advertencia!

Existe peligro de explosión si la batería se reemplaza de manera incorrecta. Reemplazar la batería exclusivamente con el mismo tipo o el equivalente recomendado por el fabricante. Desechar las baterías gastadas según las instrucciones del fabricante.

אזהרה!

קיימת סכנת פיצוץ של הסוללה במידה והוחלפה בדרך לא תקינה. יש להחליף את הסוללה בסוג התואם מחברת יצרן מומלצת.

סילוק הסוללות המשומשות יש לבצע לפי הוראות היצרן.

هناك خطر من انفجار في حالة استبدال البطارية بطريقة غير صحيحة فعليك استبدال البطارية فقط بنفس النوع أو ما يعادلها كما أوصت به الشركة المصنعة تخلص من البطاريات المستعملة وفقا لتعليمات الشركة الصانعة

경고!

배터리가 올바르게 교체되지 않으면 폭발의 위험이 있습니다. 기존 배터리와 동일하거나 제조사에서 권장하는 동등한 종류의 배터리로만 교체해야 합니다. 제조사의 안내에 따라 사용된 배터리를 처리하여 주십시오.

Waarschuwing

Er is ontploffingsgevaar indien de batterij verkeerd vervangen wordt. Vervang de batterij slechts met hetzelfde of een equivalent type die door de fabrikant aanbevolen wordt. Gebruikte batterijen dienen overeenkomstig fabrieksvoorschriften afgevoerd te worden.

Redundant Power Supplies



Warning!

This unit might have more than one power supply connection. All connections must be removed to de-energize the unit.

冗長電源装置

このユニットは複数の電源装置が接続されている場合があります。
ユニットの電源を切るためには、すべての接続を取り外さなければなりません。

警告

此部件连接的电源可能不止一个，必须将所有电源断开才能停止给该部件供电。

警告

此装置连接的電源可能不只一個，必須切斷所有電源才能停止對該裝置的供電。

Warnung

Dieses Gerät kann mehr als eine Stromzufuhr haben. Um sicherzustellen, dass der Einheit kein Strom zugeführt wird, müssen alle Verbindungen entfernt werden.

¡Advertencia!

Puede que esta unidad tenga más de una conexión para fuentes de alimentación. Para cortar por completo el suministro de energía, deben desconectarse todas las conexiones.

Attention

Cette unité peut avoir plus d'une connexion d'alimentation. Pour supprimer toute tension et tout courant électrique de l'unité, toutes les connexions d'alimentation doivent être débranchées.

אם קיים יותר מספק אחד

אזהרה!

ליחידה יש יותר מחיבור אחד של ספק. יש להסיר את כל החיבורים על מנת לרוקן את היחידה.

قد يكون لهذا الجهاز عدة اتصالات بوحدات امداد الطاقة.
يجب إزالة كافة الاتصالات لعزل الوحدة عن الكهرباء

경고!

이 장치에는 한 개 이상의 전원 공급 단자가 연결되어 있을 수 있습니다. 이 장치에 전원을 차단하기 위해서는 모든 연결 단자를 제거해야만 합니다.

Waarschuwing

Deze eenheid kan meer dan één stroomtoevoeraansluiting bevatten. Alle aansluitingen dienen verwijderd te worden om het apparaat stroomloos te maken.

Backplane Voltage



Warning!

Hazardous voltage or energy is present on the backplane when the system is operating. Use caution when servicing.

バックプレーンの電圧

システムの稼働中は危険な電圧または電力が、バックプレーン上にかかっています。

修理する際にはご注意ください。

警告

当系統正在进行时，背板上有很危险的电压或能量，进行维修时务必小心。

警告

當系統正在進行時，背板上有危險的電壓或能量，進行維修時務必小心。

Warnung

Wenn das System in Betrieb ist, treten auf der Rückwandplatine gefährliche Spannungen oder Energien auf. Vorsicht bei der Wartung.

¡Advertencia!

Cuando el sistema está en funcionamiento, el voltaje del plano trasero es peligroso. Tenga cuidado cuando lo revise.

Attention

Lorsque le système est en fonctionnement, des tensions électriques circulent sur le fond de panier. Prendre des précautions lors de la maintenance.

מתח בפנל האחורי

אזהרה!
קיימת סכנת מתח בפנל האחורי בזמן תפעול המערכת. יש להיזהר במהלך העבודה.

هناك خطر من التيار الكهربائي أو الطاقة الموجودة على اللوحة
عندما يكون النظام يعمل كن حذرا عند خدمة هذا الجهاز

경고!

시스템이 동작 중일 때 후면판 (Backplane)에는 위험한 전압이나 에너지가 발생
합니다. 서비스 작업 시 주의하십시오.

Waarschuwing

Een gevaarlijke spanning of energie is aanwezig op de backplane wanneer het
systeem in gebruik is. Voorzichtigheid is geboden tijdens het onderhoud.

Comply with Local and National Electrical Codes



Warning!

Installation of the equipment must comply with local and national electrical codes.

地方および国の電気規格に準拠

機器の取り付けはその地方および国の電気規格に準拠する必要があります。

警告

设备安装必须符合本地与本国电气法规。

警告

設備安裝必須符合本地與本國電氣法規。

Warnung

Die Installation der Geräte muss den Sicherheitsstandards entsprechen.

¡Advertencia!

La instalación del equipo debe cumplir con las normas de electricidad locales y
nacionales.

Attention

L'équipement doit être installé conformément aux normes électriques nationales et locales.

תיאום חוקי החשמל הארצי

אזהרה!

התקנת הציוד חייבת להיות תואמת לחוקי החשמל המקומיים והארציים.

تركيب المعدات الكهربائية يجب أن يمتثل للقوانين المحلية والوطنية المتعلقة بالكهرباء

경고!

현 지역 및 국가의 전기 규정에 따라 장비를 설치해야 합니다.

Waarschuwing

Bij installatie van de apparatuur moet worden voldaan aan de lokale en nationale elektriciteitsvoorschriften.

Product Disposal



Warning!

Ultimate disposal of this product should be handled according to all national laws and regulations.

製品の廃棄

この製品を廃棄処分する場合、国の関係する全ての法律・条例に従い処理する必要があります。

警告

本产品的废弃处理应根据所有国家的法律和规章进行。

警告

本產品的廢棄處理應根據所有國家的法律和規章進行。

Warnung

Die Entsorgung dieses Produkts sollte gemäß allen Bestimmungen und Gesetzen des Landes erfolgen.

¡Advertencia!

Al deshacerse por completo de este producto debe seguir todas las leyes y reglamentos nacionales.

Attention

La mise au rebut ou le recyclage de ce produit sont généralement soumis à des lois et/ou directives de respect de l'environnement. Renseignez-vous auprès de l'organisme compétent.

סילוק המוצר

אזהרה!

סילוק סופי של מוצר זה חייב להיות בהתאם להנחיות וחוקי המדינה.

عند التخلص النهائي من هذا المنتج ينبغي التعامل معه وفقا لجميع القوانين واللوائح الوطنية

경고!

이 제품은 해당 국가의 관련 법규 및 규정에 따라 폐기되어야 합니다.

Waarschuwing

De uiteindelijke verwijdering van dit product dient te geschieden in overeenstemming met alle nationale wetten en reglementen.

Hot Swap Fan Warning



Warning!

The fans might still be turning when you remove the fan assembly from the chassis. Keep fingers, screwdrivers, and other objects away from the openings in the fan assembly's housing.

ファン・ホットスワップの警告

シャーシから冷却ファン装置を取り外した際、ファンがまだ回転している可能性があります。ファンの開口部に、指、ドライバー、およびその他のものを近づけないで下さい。

警告

当您从机架移除风扇装置，风扇可能仍在转动。小心不要将手指、螺丝起子和其他物品太靠近风扇

警告

當您從機架移除風扇裝置，風扇可能仍在轉動。小心不要將手指、螺絲起子和其他物品太靠近風扇。

Warnung

Die Lüfter drehen sich u. U. noch, wenn die Lüfterbaugruppe aus dem Chassis genommen wird. Halten Sie Finger, Schraubendreher und andere Gegenstände von den Öffnungen des Lüftergehäuses entfernt.

¡Advertencia!

Los ventiladores podran dar vuelta cuando usted quite el montaje del ventilador del chasis. Mantenga los dedos, los destornilladores y todos los objetos lejos de las aberturas del ventilador

Attention

Il est possible que les ventilateurs soient toujours en rotation lorsque vous retirez le bloc ventilateur du châssis. Prenez garde à ce que doigts, tournevis et autres objets soient éloignés du logement du bloc ventilateur.

אזהרה!

כאשר מסירים את חלקי המאוורר מהמארז, יתכן והמאווררים עדיין עובדים. יש להרחיק למרחק בטוח את האצבעות וכלי עבודה שונים מהפתחים בתוך המאוורר

من الممكن أن المراوح لا تزال تدور عند إزالة كتلة المروحة من الهيكل يجب إبقاء الأصابع ومفكات البراغي وغيرها من الأشياء بعيدا عن الفتحات في كتلة المروحة.

경고!

새시로부터 팬 조립품을 제거할 때 팬은 여전히 회전하고 있을 수 있습니다. 팬 조립품 외관의 열려있는 부분들로부터 손가락 및 스크류드라이버, 다른 물체들이 가까이 하지 않도록 배치해 주십시오.

Waarschuwing

Het is mogelijk dat de ventilator nog draait tijdens het verwijderen van het ventilatorsamenstel uit het chassis. Houd uw vingers, schroevendraaiers en eventuele andere voorwerpen uit de buurt van de openingen in de ventilatorbehuizing.

Power Cable and AC Adapter



Warning!

When installing the product, use the provided or designated connection cables, power cables and AC adaptors. Using any other cables and adaptors could cause a malfunction or a fire. Electrical Appliance and Material Safety Law prohibits the use of UL or CSA -certified cables (that have UL/CSA shown on the code) for any other electrical devices than products designated by Supermicro only.

電源コードとACアダプター

製品を設置する場合、提供または指定された接続ケーブル、電源コードとACアダプターを使用下さい。他のケーブルやアダプタを使用すると故障や火災の原因になることがあります。電気用品安全法は、ULまたはCSA認定のケーブル(UL/CSEマークがコードに表記)をSupermicroが指定する製品以外に使用することを禁止しています。

警告

安裝此產品時，請使用本身提供的或指定的連接線，電源線和電源適配器。使用其它線材或適配器可能會引起故障或火災。除了Supermicro所指定的產品，電氣用品和材料安全法律規定禁止使用未經UL或CSA認證的線材。(線材上會顯示UL/CSA符號)。

警告

安裝此產品時，請使用本身提供的或指定的連接線，電源線和電源適配器。使用其它線材或適配器可能會引起故障或火災。除了Supermicro所指定的產品，電氣用品和材料安全法律規定禁止使用未經UL或CSA認證的線材。(線材上會顯示UL/CSA符號)。

Warnung

Bei der Installation des Produkts, die zur Verfügung gestellten oder benannt Anschlusskabel, Stromkabel und Netzteile. Verwendung anderer Kabel und Adapter kann zu einer Fehlfunktion oder ein Brand entstehen. Elektrische Geräte und Material Safety Law verbietet die Verwendung von UL-oder CSA-zertifizierte Kabel, UL oder CSA auf der Code für alle anderen elektrischen Geräte als Produkte von Supermicro nur bezeichnet gezeigt haben.

¡Advertencia!

Al instalar el producto, utilice los cables de conexión previstos o designados, los cables y adaptadores de CA. La utilización de otros cables y adaptadores podría ocasionar un mal funcionamiento o un incendio. Aparatos Eléctricos y la Ley de Seguridad del Material prohíbe el uso de UL o CSA cables certificados que tienen UL o CSA se muestra en el código de otros dispositivos eléctricos que los productos designados por Supermicro solamente.

Attention

Lors de l'installation du produit, utilisez les bables de connection fournis ou désigné. L'utilisation d'autres cables et adaptateurs peut provoquer un dysfonctionnement ou un incendie. Appareils électroménagers et de loi sur la sécurité Matériel interdit l'utilisation de UL ou CSA cables certifiés qui ont UL ou CSA indiqué sur le code pour tous les autres appareils électriques que les produits désignés par Supermicro seulement.

חשמליים ומתאמי AC**אזהרה!**

כאשר מתקינים את המוצר, יש להשתמש בכבלים, ספקים ומתאמים AC אשר נועדו וסופקו לשם כך. שימוש בכל כבל או מתאם אחר יכול לגרום לתקלה או קצר חשמלי. על פי חוקי שימוש במכשירי חשמל וחוקי בטיחות, קיים איסור להשתמש בכבלים המוסמכים ב- UL או ב- CSA (כשאר מופיע עליהם קוד של UL/CSA) עבור כל מוצר חשמלי אחר שלא צויין על ידי סופרמיקרו בלבד.

عند تركيب الجهاز يجب استخدام كابلات التوصيل، والكابلات الكهربائية ومحولات التيار المتردد التي . أن استخدام أي كابلات ومحولات أخرى يتسبب في حدوث عطل أو حريق. تم توفيرها لك مع المنتج الأجهزة الكهربائية ومواد قانون السلامة يحظر استخدام الكابلات CSA أو UL معتمدة من قبل لأي أجهزة كهربائية أخرى غير المنتجات المعينة من قبل Supermicro (التي تحمل علامة UL/CSA)

경고!

제품을 설치할 때에는 제공되거나 지정된 연결케이블과 전원케이블, AC 어댑터를 사용해야 합니다. 그 밖의 다른 케이블들이나 어댑터들은 고장 또는 화재의 원인이 될 수 있습니다. 전기용품안전법 (Electrical Appliance and Material Safety Law)은 슈퍼마이크로에서 지정한 제품들 외에는 그 밖의 다른 전기 장치들을 위한 UL 또는 CSA에서 인증한 케이블(전선 위에 UL/CSA가 표시)들의 사용을 금지합니다.

Waarschuwing

Bij het installeren van het product, gebruik de meegeleverde of aangewezen kabels, stroomkabels en adapters. Het gebruik van andere kabels en adapters kan leiden tot een storing of een brand. Elektrisch apparaat en veiligheidsinformatiebladen wet verbiedt het gebruik van UL of CSA gecertificeerde kabels die UL of CSA die op de code voor andere elektrische apparaten dan de producten die door Supermicro alleen.

Notes

Chapter 3

Chassis Components

3-1 Overview

This chapter describes the most common components included with your chassis. Some components listed may not be included or compatible with your particular chassis model. For more information, see the installation instructions detailed later in this manual.

3-2 Components

For the latest shipping lists, visit our Web site at: www.supermicro.com.

Drives

The chassis includes eight hard disk drive bays, which support 2.5" hot-swap hard disk drives. The hard drives must be purchased separately.

The chassis also supports an optional slim DVD drive.

Motherboard

The chassis supports motherboards of size 13.68" x 13", E-ATX and ATX with single or dual processors from Intel or AMD.

Backplane

The chassis comes with a backplane which supports SAS/SATA. For more information regarding compatible backplanes, see the appendices at the end of this manual.

Expansion Cards

The chassis supports six or seven expansion cards. The LP models accommodate seven low profile cards. The UB models support four full height expansion cards and three low profile cards, or a Supermicro universal I/O (UIO) card plus three full height expansion cards and three low profile cards.

Power Supply

Each chassis includes a high-efficiency power supply rated at 560, 600, or 720 Watts.

Fans

The chassis supports three system fans. System fans are powered from the motherboard or the backplane. Fan speed may be controlled if the motherboard has either PWM or DC control ability. An air shroud helps channel the airflow for optimum cooling.

Mounting Rails

The chassis can be mounted in a rack and rails are included.

3-3 Where to get Replacement Components

Infrequently, you may need replacement parts for your system. To ensure the highest level of professional service and technical support, we strongly recommend purchasing exclusively from our Supermicro authorized distributors, system integrators and resellers. A list of Supermicro authorized distributors, system integrators and resellers can be found at: <http://www.supermicro.com>. Click the Where to Buy link.

Chapter 4

System Interface

4-1 Overview

The chassis includes:

- A control panel on the front, left handle that includes power buttons and status monitoring lights
- Status lights on externally accessible hard drives
- Status lights for the power supply

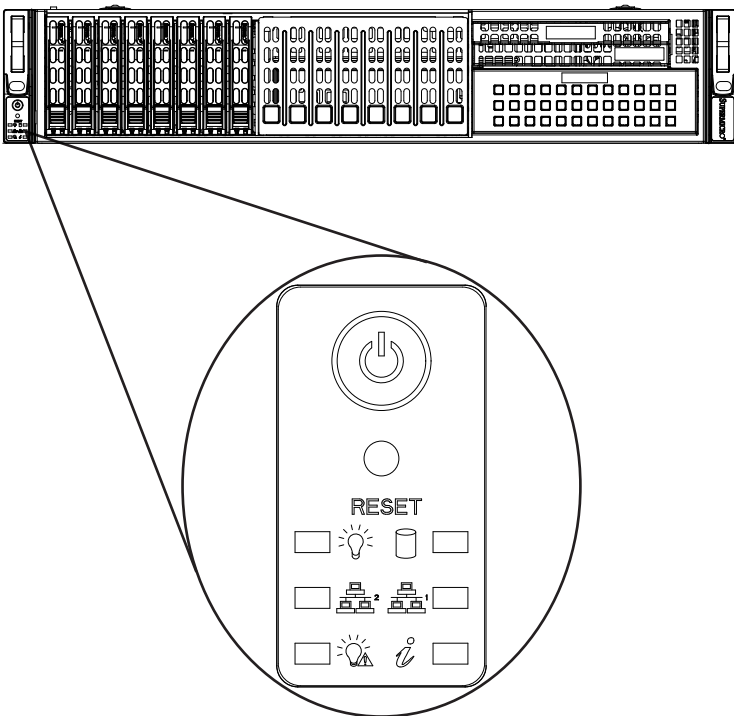

Figure 4-1. Chassis Control Panel

4-2 Control Panel Buttons

The chassis includes two push-buttons that control power to the system.



Power: The main power switch is used to apply or remove power from the power supply to the server. Turning off system power with this button removes the main power but maintains standby power. To perform many maintenance tasks, you must unplug system before servicing.



RESET

Reset: The reset button is used to reboot the system. A needle, pen, or other small device is required to activate this button and reset the system

4-3 Control Panel LEDs

There are six LEDs that provide status information about the system.



Power: Indicates power is being supplied to the system power supply units. This LED should normally be illuminated when the system is operating.



HDD: Indicates IDE channel activity on the hard drive when flashing.



NIC2: Indicates network activity on GLAN2 when flashing.



NIC1: Indicates network activity on GLAN1 when flashing.



Power Failure: When flashing, indicates a failure of the power supply



Information LED: Alerts operator of several states, as noted in the table below.

Information LED	
Status	Description
Continuously on and red	An overheat condition has occurred. (This may be caused by cable congestion.)
Blinking red (1Hz)	Fan failure, check for an inoperative fan.
Blinking red (0.25Hz)	Power failure, check for a non-operational power supply.
Solid blue	Local UID has been activated. Use this function to locate the server in a rack mount environment.
Blinking blue	Remote UID is on. Use this function to identify the server from a remote location.

Overheating

There are several possible responses if the system overheats.

Overheat Temperature Setting

Some backplanes allow the overheat temperature to be set at 45, 50, or 55 degrees by changing a jumper setting. For more information, consult the backplane user manual at www.supermicro.com. (Click **Support > Manuals**.)

Responses

If the server overheats:

1. Use the LEDs to determine the nature of the overheating condition.
2. Confirm that the chassis covers are installed properly.

3. Check the routing of the cables and make sure all fans are present and operating normally.
4. Verify that the heatsinks are installed properly.

4-4 Drive Carrier LEDs

The chassis includes externally accessible SAS/SATA drives. Each drive carrier displays two status LEDs on the front of the carrier.

- **Green:** When illuminated, this LED indicates drive activity. It blinks on and off when that particular drive is being accessed. This function is controlled by the backplane.
- **Red:** When illuminated, this LED indicates a drive failure. You should be notified by your system management software.

4-5 Power Supply LEDs

On the rear of the power supply module, an LED displays the status.

- **Solid Green:** When illuminated, indicates that the power supply is on.
- **Solid Amber:** When illuminated, indicates the power supply is plugged in and turned off, or the system is off but in an abnormal state.
- **Blinking Amber:** When blinking, this system power supply temperature has reached 63°C. The system will automatically power-down when the power supply temperature reaches 70°C and restarts when the power supply temperature goes below 60°C.

Chapter 5

Chassis Setup and Maintenance

5-1 Overview

This chapter covers the steps required to install components and perform maintenance on the chassis. The only tool required is a Phillips screwdriver.

Review the warnings and precautions listed in the manual before setting up or servicing this chassis. These include information in Chapter 2: System Safety and the warning/precautions listed in the setup instructions.

5-2 Removing Power from the System

Before performing most setup or maintenance tasks, use the following procedure to ensure that power has been removed from the system.

1. Use the operating system to power down the system <or node>, following the on-screen prompts.
2. After the system has completely shut-down, carefully grasp the head of the power cord and gently pull it out of the back of the power supply. If your system has dual power supplies, remove the cords from both power supplies.
3. Disconnect the cord from the power strip or wall outlet.

5-3 Removing the Chassis Cover

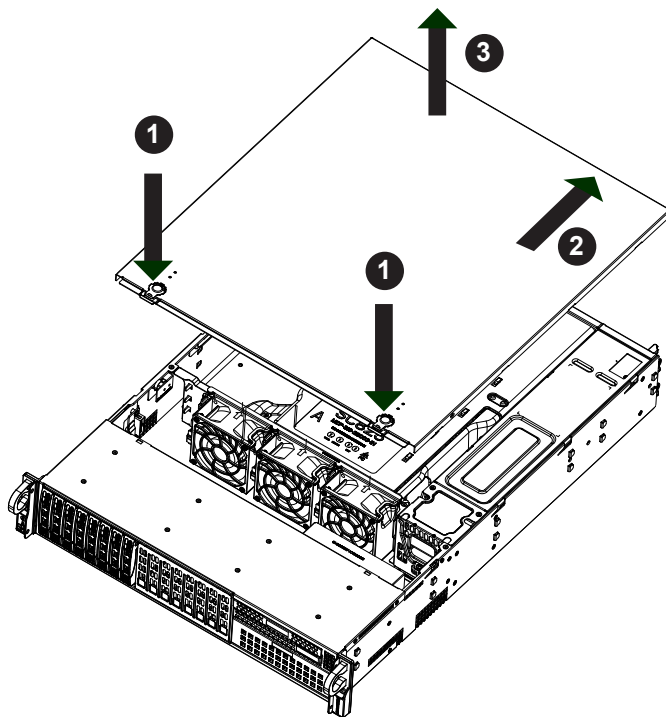

Figure 5-1. Removing the Chassis Cover

Removing the Chassis Cover

1. Press both release tabs at the same time to release the cover from the locked position.
2. Once the top cover has been released, slide the cover backwards, toward the rear of the chassis.
3. Lift the cover up and off the chassis.

Caution: Except for short periods of time, do not operate the system without the cover in place. The chassis cover must be in place to allow proper airflow and prevent overheating.

5-4 Installing Hard Drives

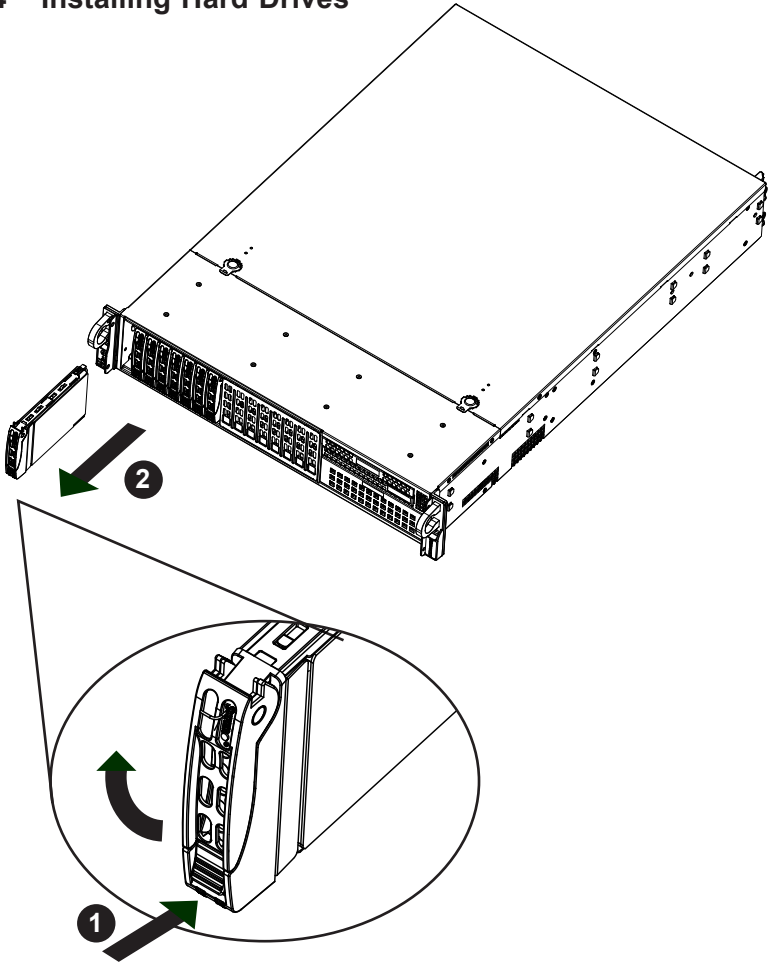

Figure 5-2 Removing Hard Drive Carrier

The SC213L comes equipped with eight hot-swappable hard drives. They are mounted in carriers for ease of handling. Only SAS or enterprise SATA HDDs are recommended.

Removing Hard Drive Trays from the Chassis

1. Press the release button on the drive carrier. This extends the drive carrier handle.
2. Hold the handle to pull the tray out of the chassis.

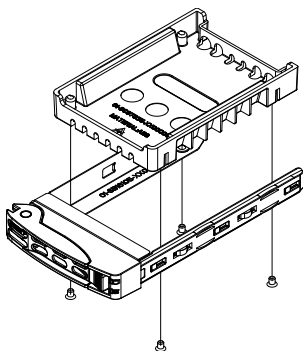

Figure 5-3. Chassis Drive Carrier

Installing a Hard Drive into a Drive Carrier

1. Insert a drive into the carrier with the PCB side facing down and the connector end toward the rear of the carrier.
2. Align the drive in the carrier so that the mounting holes of both are aligned. Note that there are holes in the carrier marked "SAS" or "SATA" to aid in correct installation.
3. Secure the drive to the carrier with four screws as illustrated above. Use the four M3 flat-head screws included in the HDD bag of your accessory box. Note that the screws used to secure the dummy drive to the tray cannot be used to secure the hard drive.
4. Insert the hard drive and drive carrier into its bay vertically, keeping the carrier oriented so that the release button is on the bottom. When the carrier reaches the rear of the bay, the release handle will retract.
5. Using the thumb, push against the upper part of the hard drive handle. Push the hard drive into the hard drive bay as illustrated below, until the hard drive clicks into the locked position.

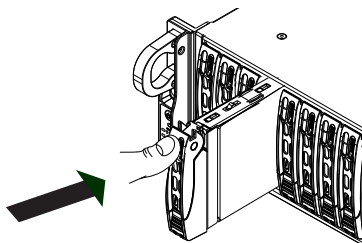

Figure 5-4. Installation of the Hard Drive into the Hard Drive Bay

5-5 Installing the Motherboard

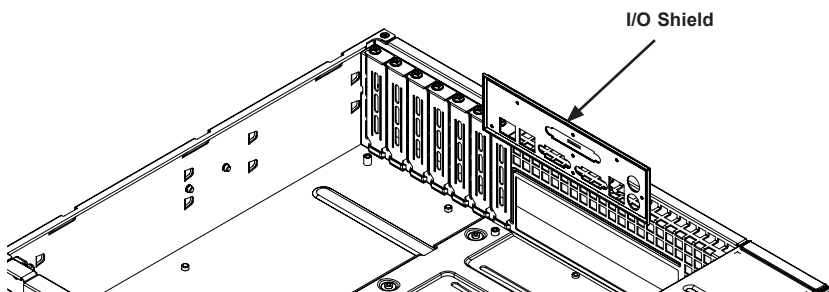

Figure 5-5. I/O Shield Placement

I/O Shield

The I/O shield holds the motherboard ports in place. Install the I/O shield before installing the motherboard. If the motherboard you purchased did not include a standard I/O shield, contact the motherboard vendor.

Installing the I/O Shield

1. Review the documentation that came with your motherboard. Become familiar with component placement, requirements, and precautions.
2. Open the chassis cover.
3. With the illustrations facing the outside of the chassis, place the I/O shield into the space provided at the rear of the chassis as illustrated above.

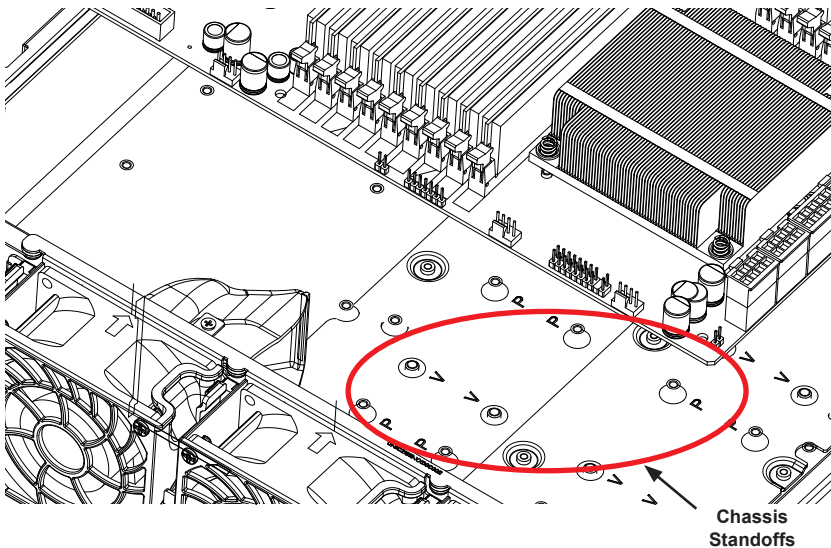

Figure 5-6. Chassis Standoffs

Permanent and Optional Standoffs

Standoffs prevent short circuits by creating space between the motherboard and the chassis surface. The SC213L chassis includes permanent standoffs in locations used by most motherboards. These standoffs accept the rounded Phillips head screws which are included in the accessories packaging.

Some motherboards require additional screws for heatsinks, general components and/or non-standard security. Optional standoffs are included for these motherboards. To use an optional standoff, place the hexagonal nut with the rounded side up, in the holes provided on the floor of the chassis.

Installation Procedure

Installing the Motherboard

1. Review the documentation that came with your motherboard. Become familiar with component placement, requirements, precautions, and cable connections.
2. Open the chassis cover.
3. If necessary, remove the air shroud and riser card bracket.
4. Ensure that the I/O shield has been installed correctly.

5. As required by your motherboard, install standoffs in any areas that do not have a permanent standoff and remove any standoffs that are not required by the motherboard.
6. Lay the motherboard in the chassis aligning the permanent and optional standoffs.
7. Secure the motherboard to the chassis using the rounded, Phillips head screws which are included in the motherboard bag of the accessory box. Do not exceed eight inch-lbs of torque when tightening the screws.
8. Secure the CPUs, heatsinks, and other components to the motherboard as described in the motherboard documentation.
9. Connect the cables between the motherboard, backplane, chassis, front panel, and power supply, as needed. The fans may be temporarily removed to allow access to the backplane ports and to allow for ease of installation.

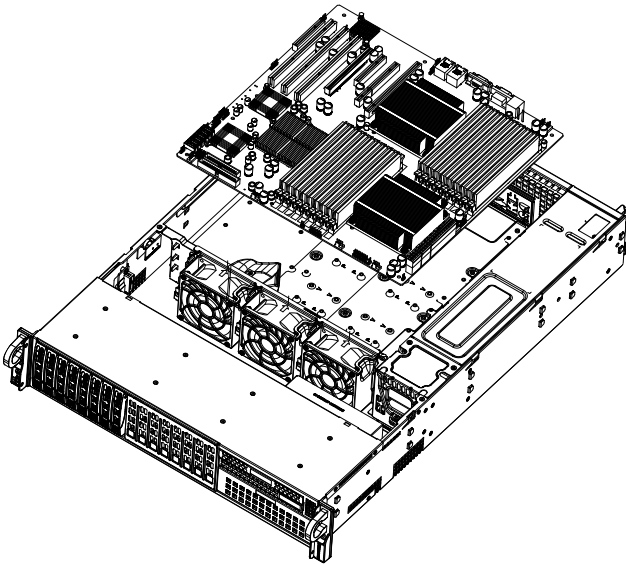

Figure 5-7. Installing the Motherboard

5-6 Installing Expansion Cards

For the LP models, such as SC213LT-563LPB, the chassis slots are vertical and allow the addition of low profile expansion cards. The U models, such as SC213LT-563UB, allow a Supermicro universal I/O (UIO) card and more expansion cards. The slots are horizontal.

The motherboard must be installed before expansion cards.

Installing an Expansion Card for an LP Model Chassis

1. Power down the system as described in Section 5-2 and remove the cover.
2. In the rear of the chassis, remove the blank PCI shield that is pre-installed covering the expansion slot.

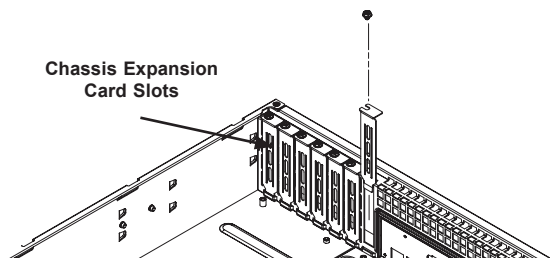

Figure 5-8. Removing the PCI Shield in an LP Model

3. Slide the expansion card into the expansion slot on the motherboard while aligning it with the chassis slot in the rear of the chassis.
4. Secure the expansion card shield onto the rear of the chassis with a screw.

Expansion Cards for a U Model Chassis

The U model chassis, such as SC213LT-563UB, accommodates expansion cards using riser cards. If your motherboard supports a Supermicro universal I/O (UIO) card, the chassis supports an additional three full-height expansion cards and three low profile expansion cards. If the motherboard does not support a UIO, then the chassis supports four full-height expansion cards and three low profile expansion cards.

Installing a UIO Card

1. Power down the system as described in Section 5-2 and remove the cover.
2. Release the clamp that secures all four full-height PCI shields (Figure 5-10). Looking at the rear of the chassis, this clamp is in the right corner. Unscrew

the single screw that secures the clamp and rotate the clamp away from the shields. Remove the blank PCI shield that is pre-installed covering the expansion slot in the chassis.

3. Place the UIO card horizontally in the rear left area of the chassis bottom and insert it into the blue UIO slot in the motherboard, while aligning it with slot in the rear of the chassis.
4. Secure the shield to the rear of the chassis with the lever.

Installing an Expansion Card for a U Model Chassis

1. If this is the first expansion card, start by locating the *riser card bracket* in your chassis accessory bag, and one or two riser cards, which are purchased separately. One riser card accommodates the full-height expansion cards and another riser card accommodates the three low profile expansion cards.
2. Power down the system as described in Section 5-2 and remove the cover.
3. Attach the riser card(s) to the riser card bracket using screws. Note that there are different cards for the right and left side of the bracket.
4. Insert the riser card(s) into the motherboard expansion slot(s) while aligning the riser card bracket with the rear of the chassis. Secure the bracket with screws.

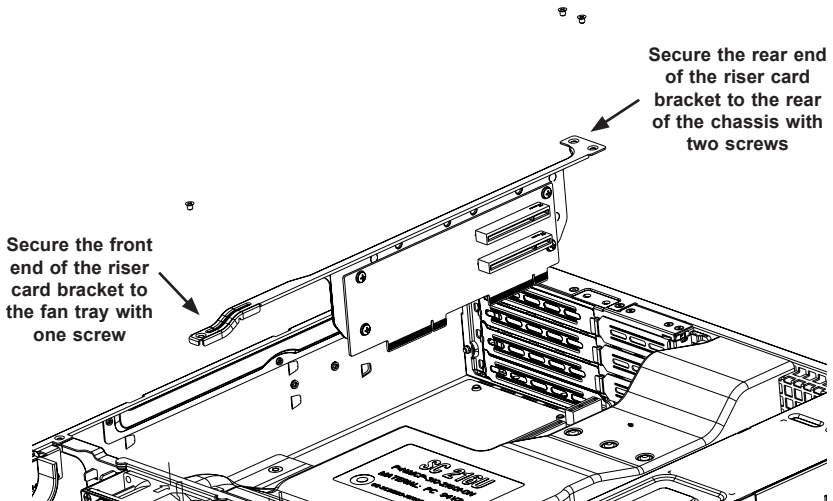
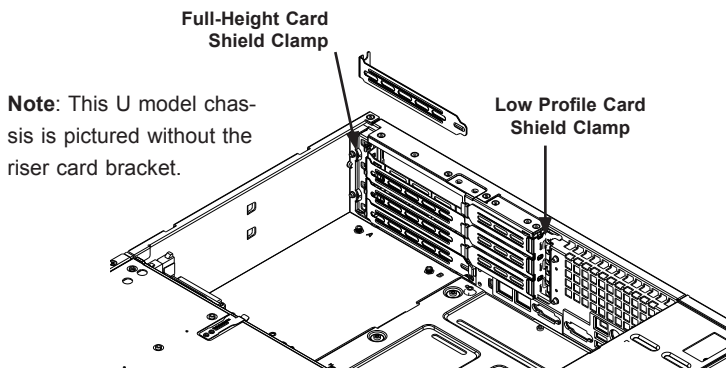

Figure 5-9. Installing the Riser Card Bracket in a U Model



Note: This U model chassis is pictured without the riser card bracket.

Figure 5-10. Remove an Expansion Card Slot Shield

5. For a **full-height** extension card, release the clamp that secures all four PCI shields. Looking at the rear of the chassis, this clamp is in the right corner. Unscrew the single screw that secures the clamp and rotate the clamp away from the shields.

For a **low profile** extension card, release the box-shaped clamp that secures all three PCI shields. Looking at the rear of the chassis, this clamp is near the middle, just left of the low profile PCI slots. Unscrew the single screw that secures the clamp and slide the clamp to the left away from the shields.

6. Insert the expansion card into a slot on the riser card while aligning the expansion card backplate with the open slot in the rear of the chassis. Repeat for other expansion cards if you are installing more than one.
7. Secure the card backplates to the chassis by returning the clamp to the closed position and installing the locking screw.
8. Replace the chassis cover and power up.

5-7 Installing the Air Shroud

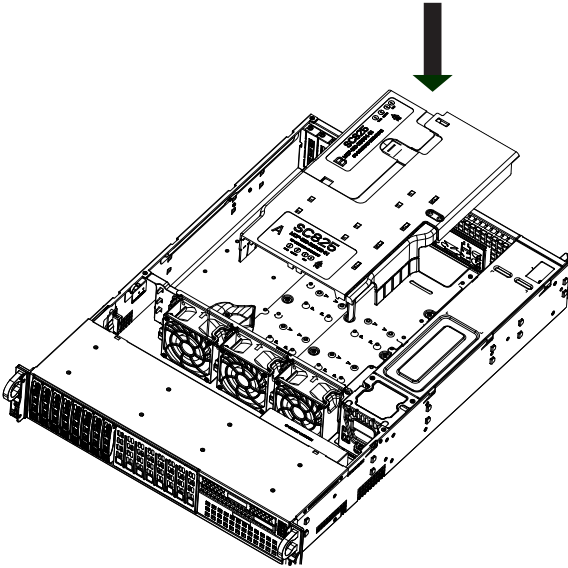

Figure 5-11. Air Shroud Installation

Air shrouds concentrate airflow to maximize fan efficiency. The SC213L air shroud does not require screws for installation.

Installing the Air Shroud

1. Remove the chassis cover.
2. Place the air shroud in the chassis. The air shroud fits just behind the three fans in the fan rack. Slide the air shroud into the grooves just behind the fan rack. If necessary, move any cables that interfere with the air shroud placement.

Note that some motherboards may require the air shroud to be modified to fit over the motherboard. The air shroud is designed with break-away pieces that may be removed to accommodate differing styles of motherboards.

Checking the Air Flow

- Make sure there are no objects to obstruct airflow in and out of the server. In addition, if you are using a front bezel, make sure the bezel's filter is replaced periodically.
- Do not operate the server without drives or drive trays in the drive bays. Use only recommended server parts.
- Make sure no wires or foreign objects obstruct air flow through the chassis. Pull all excess cabling out of the airflow path or use shorter cables.

The control panel LEDs inform you of system status. See Chapter 3: System Interface for details on the LEDs and the control panel buttons.

Installation Complete

In most cases, the chassis power supply and fans are pre-installed. If you need to install fans continue to the Systems Fan section of this chapter. If the chassis will be installed into a rack, continue to the next chapter for rack installation instructions.

5-8 System Fans

Three 8cm heavy duty fans provide cooling for the chassis internal temperature. The fans are hot-swappable, enabling the fans to be replaced without powering-down the system.

Replacing a System Fan

1. If necessary, open the chassis while the power is running to determine which fan requires changing. (Never run the server for an extended period of time with the chassis open.)
2. Press the fan release tab to lift the failed fan from the chassis and pull it completely out of the chassis.

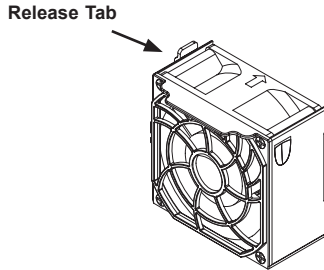

Figure 5-12. System Fan

3. Place the new fan into the vacant space in the housing while making sure the arrows on the top of the fan (indicating air direction) point in the same direction as the arrows on the other fans. The fan will automatically begin running at the correct speed.

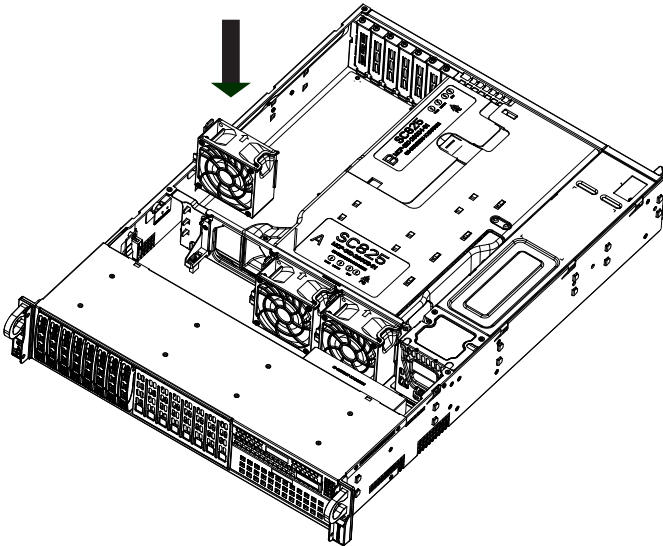

Figure 5-13. Placing System Fan

5-9 Power Supply

The chassis may have a single power supply or two redundant power supplies, depending on the model. In either case, the power supplies automatically sense the input voltage from 100v to 240v and operate accordingly.

A green light on the power supply indicates that the power supply is operating. An amber light indicates the system power is off.

Single Unit

Changing a Single Power Supply

1. Unplug the power cord.
2. On the back of the unit, push the release tab and pull the power supply out using the handle.
3. Push the new power supply module into the power bay until the tab clicks into the locked position.
4. Plug in the AC power cord.

Redundant Units

The power modules are hot-swappable, so they can be changed without powering down the system. This is facilitated by the power distributor in the chassis.

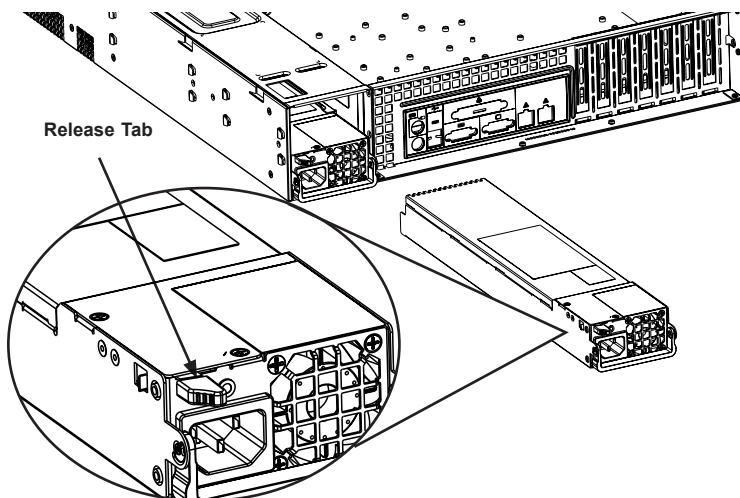

Figure 5-14. Removing the Power Supply

Changing a Redundant Power Supply

1. Determine which power supply needs to be replaced and unplug the power cord to that module.
2. On the back of the unit, push the release tab and pull the power supply out using the handle.
3. Replace with a the same model unit. Push the new power supply module into the power bay until the tab clicks into the locked position.
4. Plug the AC power cord back into the module and the replacement power module will automatically power-up.

Installing the Power Distributor

The power distributor provides failover and power supply redundancy and is pre-installed in the chassis. In the rare event that you have to replace the power distributor, follow the steps below.

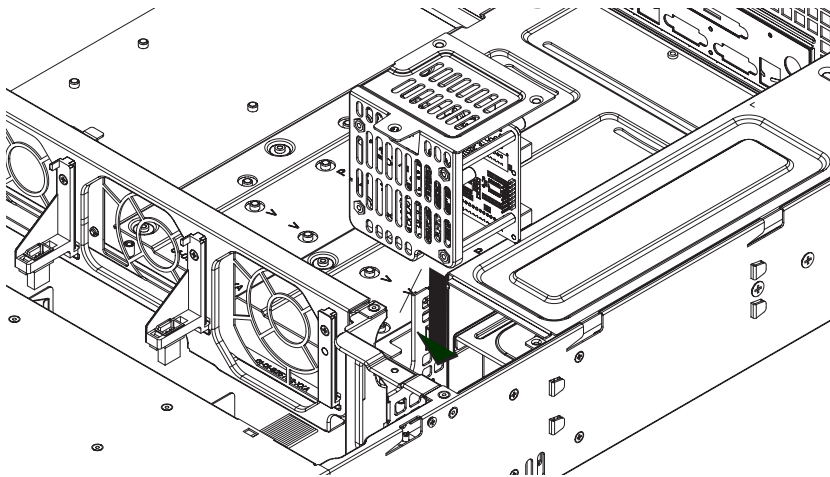

Figure 5-15. Installing the Power Distributor

Changing the Power Distributor

1. Power down the server and unplug the power cord from the power module.
2. Remove all cable connections to the power supply from the motherboard, backplane, and other components. Also, remove both power supply modules.
3. Remove the screws securing the power distributor.
4. Gently pull the power distributor from the chassis. Gently guide all the cables through the power distributor housing.
5. Slide the new power distributor module into the power distributor housing. Make that you slide the cables through the bottom of the housing.
6. Reconnect all the power cables, replace the power supply, and insert the plug into the wall.

5-10 Backplane

The backplane is located behind the hard drives and in front of the system fans. In order to change jumper settings on the backplane, it may be necessary to remove the backplane from the chassis.

Removing the Backplane from the Chassis

1. Power down the system as described in Section 5-2 and remove the cover.
2. Disconnect the cabling to the backplane.
3. Remove all of the hard drives from the hard drive bays in the front of the chassis
4. Remove the two upper screws at the top of the backplane, indicated by the arrows below.
5. Gently ease the backplane up and out of the chassis.

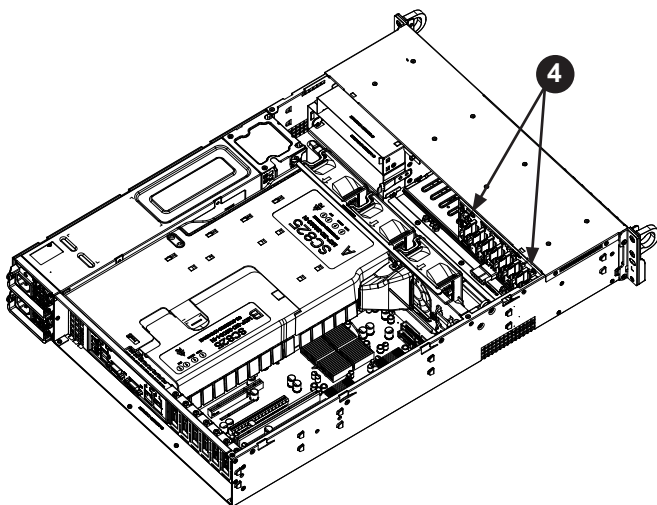

Figure 5-16. Removing the Screws at the Top of the Backplane

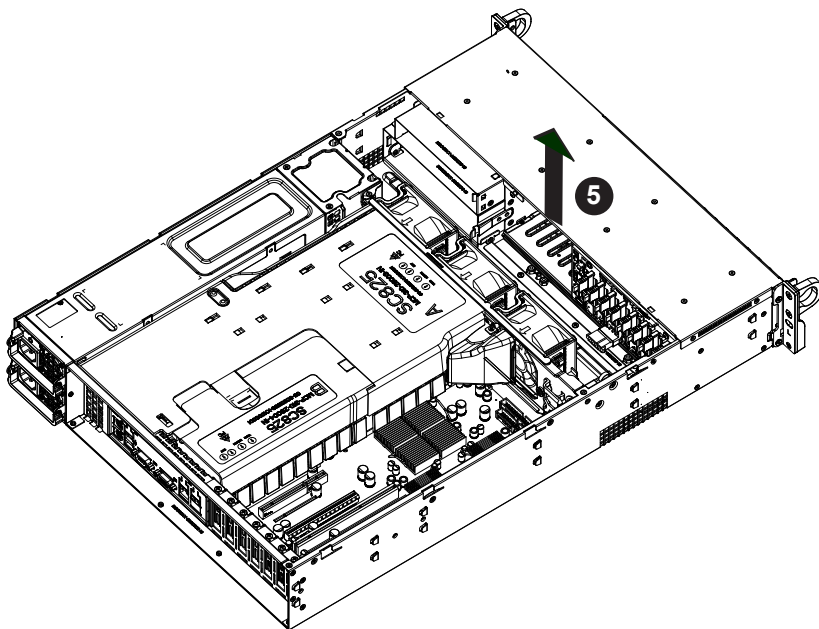
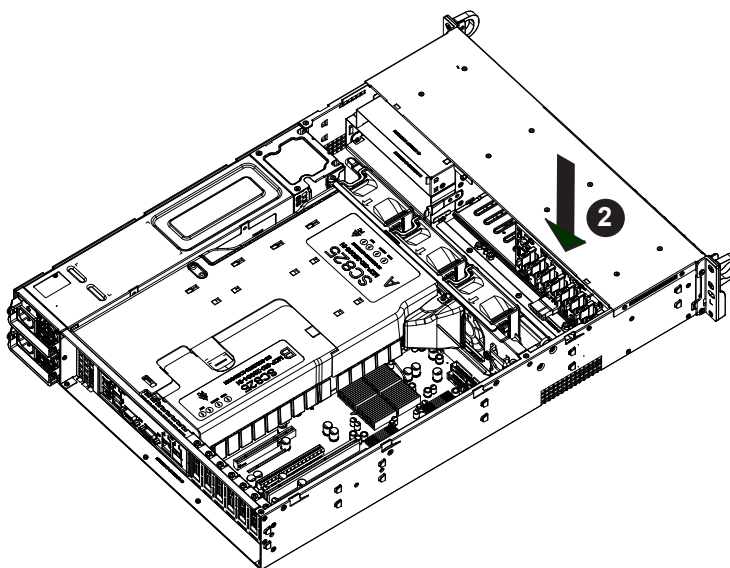

Figure 5-17. Removing the Backplane

Installing the Backplane into the Chassis

1. Ensure that all of the hard drive trays have been removed from the bays in the front of the chassis and that the spring bar has been loosened.
2. Slide the backplane into the chassis, easing it into the clips on the floor of the chassis.
3. Align the mounting holes in the backplane with the holes in the chassis. Replace the two screws at the top of the backplane.
4. Reconnect all cables and return the hard drive trays to their bays in the front of the chassis.

**Figure 5-18. Installing the Backplane**

Chapter 6

Rack Installation

This chapter provides instructions for preparing and mounting your chassis in a rack.

6-1 Unpacking the System

You should inspect the box the chassis was shipped in and note if it was damaged in any way. If the chassis itself shows damage, file a damage claim with the carrier who delivered it.

6-2 Preparing for Setup

Decide on a suitable location for the rack unit that will hold your chassis. It should be a clean, dust-free area that is well ventilated. Avoid areas where heat, electrical noise and electromagnetic fields are generated. A nearby grounded power outlet is required.

The box your chassis was shipped in should include two sets of rail assemblies, two rail mounting brackets and the mounting screws to mount the system into the rack. Please read this chapter in its entirety before beginning the installation procedure.

Choosing a Setup Location

- Leave at least 25 inches clearance in front of the rack to open the front door completely.
- Leave approximately 30 inches of clearance in the back of the rack to allow for sufficient airflow and access for servicing.
- It should be a restricted access location, such as a dedicated equipment room or a service closet.

6-3 Warnings and Precautions

Rack Precautions

- Ensure that the leveling jacks on the bottom of the rack are fully extended to the floor with the full weight of the rack resting on them.
- In single rack installations, stabilizers should be attached to the rack.
- In multiple rack installations, the racks should be coupled together.
- Always make sure that the rack is stable before extending a component from the rack.
- Only one chassis should be extended from the rack at a time. Extending two or more chassis simultaneously may cause the rack to become unstable.

General Server Precautions

- Review the electrical and general safety precautions that came with the components you are adding to your chassis.
- Determine the placement of each component in the rack *before* you install the rails.
- Install the heaviest server components on the bottom of the rack first, and then work upward.
- Use a regulating uninterruptible power supply (UPS) to protect the server from power surges, voltage spikes and to keep your system operating in case of a power failure.
- Allow the hot-swappable hard drives and power supply modules to cool before touching them.
- Always keep the rack's front door and all panels and components on the servers closed when not servicing to maintain proper cooling.

Rack Mounting Considerations

Ambient Operating Temperature

If installed in a closed or multi-unit rack assembly, the ambient operating temperature of the rack environment may be greater than the ambient temperature of the room. Therefore, consideration should be given to installing the equipment in an environment compatible with the manufacturer's maximum rated ambient temperature (TMRA).

Sufficient Airflow

Equipment should be mounted into a rack so that the amount of airflow required for safe operation is not compromised.

Circuit Overloading

Consideration should be given to the connection of the equipment to the power supply circuitry and the effect that any possible overloading of circuits might have on overcurrent protection and power supply wiring. Appropriate consideration of equipment nameplate ratings should be used when addressing this concern.

Reliable Ground

A reliable ground must be maintained at all times. To ensure this, the rack itself should be grounded. Particular attention should be given to power supply connections other than the direct connections to the branch circuit (i.e. the use of power strips, etc.).



Warning: To prevent bodily injury when mounting or servicing this unit in a rack, you must take special precautions to ensure that the system remains stable. The following guidelines are provided to ensure your safety:

- This unit should be mounted at the bottom of the rack if it is the only unit in the rack.
- When mounting this unit in a partially filled rack, load the rack from the bottom to the top with the heaviest component at the bottom of the rack.
- If the rack is provided with stabilizing devices, install the stabilizers before mounting or servicing the unit in the rack.

6-4 Installing the System into a Rack

This section provides information on installing the chassis into a rack unit with the rails provided. There are a variety of rack units on the market, which may mean that the assembly procedure will differ slightly from the instructions provided. You should also refer to the installation instructions that came with the rack unit you are using. **Note:** This rail will fit a rack between 26.5" and 36.4" deep.

Identifying the Sections of the Rack Rails

The chassis package includes two rail assemblies. Each assembly consists of three sections: An inner rail that secures directly to the chassis, an outer rail that secures to the rack, and a middle rail which extends from the outer rail. These assemblies are specifically designed for the left and right side of the chassis.

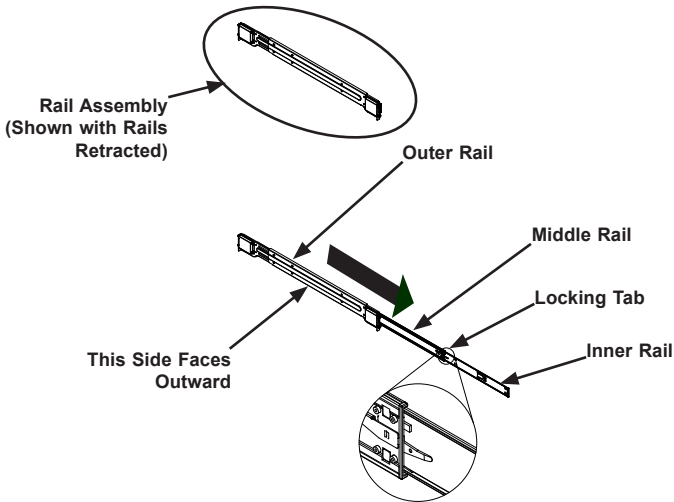

Figure 6-1. Identifying the Outer Rail, Middle Rail and Inner Rail
(Left Rail Assembly Shown)

Releasing the Inner Rail

Each inner rail has a locking latch. This latch prevents the server from coming completely out of the rack when the chassis is pulled out for servicing.

To mount the rail onto the chassis, first release the inner rail from the outer rails.

Releasing Inner Rail from the Outer Rails

1. Pull the inner rail out of the outer rail until it is fully extended as illustrated below.
2. Press the locking tab down to release the inner rail.
3. Pull the inner rail all the way out.
4. Repeat for the other outer rail.

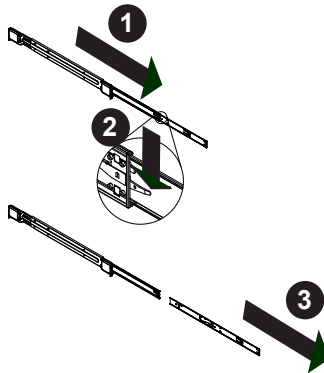

Figure 6-2. Extending and Releasing the Inner Rail

Installing the Inner Rails on the Chassis

Installing the Inner Rails

1. Identify the left and right inner rails. They are labeled.
2. Place the inner rail firmly against the side of the chassis, aligning the hooks on the side of the chassis with the holes in the inner rail.
3. Slide the inner rail forward toward the front of the chassis until the quick release bracket snaps into place, securing the rail to the chassis.
4. Optionally, you can further secure the inner rail to the chassis with a screw.
5. Repeat for the other inner rail.

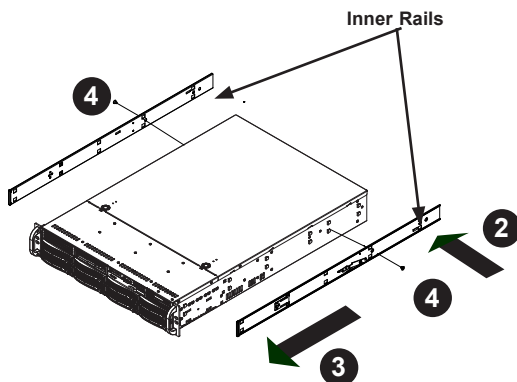

Figure 6-3. Installing the Inner Rails

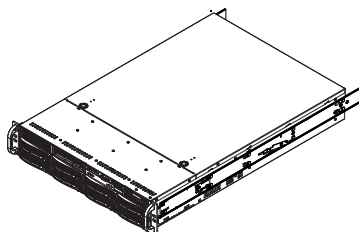

Figure 6-4. Inner Rails Installed on the Chassis

Installing the Outer Rails onto the Rack

Installing the Outer Rails

1. Press upward on the locking tab at the rear end of the middle rail.
2. Push the middle rail back into the outer rail.
3. Hang the hooks on the front of the outer rail onto the square holes on the front of the rack. If desired, use screws to secure the outer rails to the rack.
4. Pull out the rear of the outer rail, adjusting the length until it just fits within the posts of the rack.
5. Hang the hooks of the rear section of the outer rail onto the square holes on the rear of the rack. Take care that the proper holes are used so the rails are level. If desired, use screws to secure the rear of the outer rail to the rear of the rack.
6. Repeat for the other outer rail.

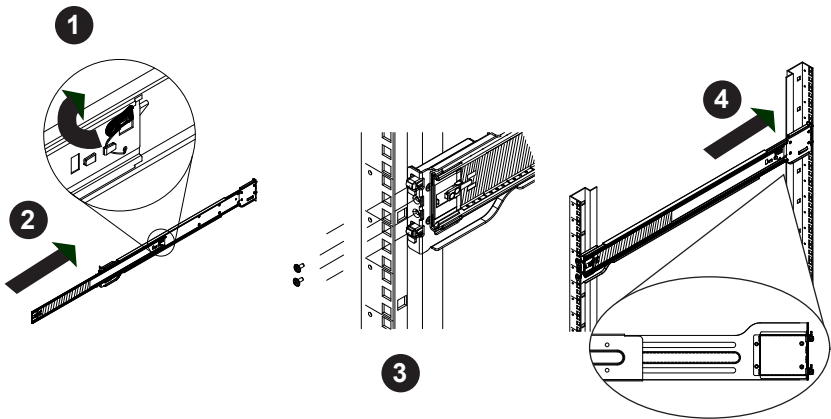

Figure 6-5. Extending and Mounting the Outer Rails



Stability hazard. The rack stabilizing mechanism must be in place, or the rack must be bolted to the floor before you slide the unit out for servicing. Failure to stabilize the rack can cause the rack to tip over.

Do not use a two post "telco" type rack.

Sliding the Chassis onto the Rack Rails



Warning: Mounting the system into the rack requires at least two people to support the chassis during installation. Please follow safety recommendations printed on the rails.

Installing the Chassis into a Rack

1. Extend the outer rails as illustrated above.
2. Align the inner rails of the chassis with the outer rails on the rack.
3. Slide the inner rails into the outer rails, keeping the pressure even on both sides. When the chassis has been pushed completely into the rack, it should click into the locked position.
4. Optional screws may be used to hold the front of the chassis to the rack.

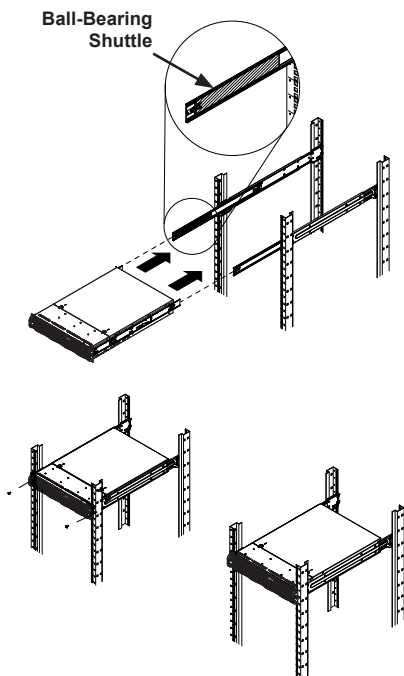

Figure 6-6. Installing into a Rack

Note: The figure above is for illustrative purposes only. Always install servers to the bottom of the rack first.



Caution: Do not pick up the server with the front handles. They are designed to pull the system from a rack only.

Appendix A

SC213L Chassis Cables

A-1 Overview

This appendix lists supported cables for your chassis system. It only includes the most commonly used components and configurations. For more compatible cables, refer to the manufacturer of the motherboard you are using and our Web site at: www.supermicro.com.

A-2 Cables Included with SC213L Chassis (SAS/SATA)

SC213L-R720LPB			
Part #	Type	Length	Description
CBL-0087	Cable	20"	Round 16 to 16 pin ribbon front panel cable
CBL-0088L	Cable	10.5"	4-pin middle fan power extension (PWM)
CBL-0217L	Cable	8.66"	16-pin control panel converter cable,

A-3 Compatible Cables

These cables are compatible with the SC213L Chassis.

Alternate SAS/SATA Cables

Some compatible motherboards have different connectors. If your motherboard has only one SAS connector that the SAS/SATA cables must share, use one of the following cables. These cables must be purchased separately.

Cable Name: SAS Cable

Quantity: 1

Part #: CBL-0175L

Alt. Name: "Big Four"

Description: This cable has one SFF-8484 (32 pin) connector on one end and 4 SAS connectors (7 pins each) at the other. This cable connects from the Host (motherboard or other controller) to the backplane SAS hard drive port.

Cable Name: SAS Cable

Quantity: 1

Part #: CBL-0116

Alt. Name: iPass or "Small Four"

Description: This cable has one ipass (SFF-8087/mini-sas) connector (36 pins) at one end and 4 SAS connectors on one end. This cable connects from the Host (motherboard or other controller) to the backplane SAS hard drive port.

Extending Power Cables

Although Supermicro chassis are designed to be efficient and cost-effective, some compatible motherboards have power connectors located in different areas.

To use these motherboards you may have to extend the power cables to the motherboards. To do this, use the following chart as a guide.

Power Cable Extenders		
Number of Pins	Cable Part #	Length
24 pin	CBL - 0042	7.9"(20 CM)
20 pin	CBL - 0059	7.9"(20 CM)
8 pin	CBL - 0062	7.9"(20 CM)
4 pin	CBL - 0060	7.9"(20 CM)

Front Panel to the Motherboard

The SC213L chassis includes a cable to connect the chassis front panel to the motherboard. If your motherboard uses a different connector, use the following list to find a compatible cable.

Front Panel to Motherboard Cable (Ribbon Cable)		
Number of Pins (Front Panel)	Number of Pins (Motherboard)	Cable Part #
16 pin	16 pin	CBL - 0049
16 pin	20 pin	CBL - 0048
20 pin	20 pin	CBL - 0047
16 pin	varies*	CBL - 0068
20 pin	varies*	CBL - 0067

* Split cables: Use these cables if your motherboard requires several different connections from the front panel.

Notes

Appendix B

SC213L Power Supply Specifications

This appendix lists power supply specifications for your chassis system.

SC213LTQ-R720LPB, SC213LTQ-R720UB	
	720W
MFR Part #	PWS-721P-1R with PDB
AC Input	100 - 240V 60 - 50Hz 9-4 Amp
DC Output	
+5V standby	3 Amp
+12V	59 Amp
+5V	45 Amp
+3.3V	24Amp
-12V	0.6 Amp



SC213LT-563LPB, SC213LT-563UB	
	560W
MFR Part #	PWS-563-1H20
AC Input	100 - 240V 60 - 50Hz 7.5 Amp maximum
DC Output	
+5V standby	3 Amp
+12V	46 Amp at 100V-180V 49 Amp at 180V-420V
+5V	18 Amp
+3.3V	15 Amp
-12V	0.5 Amp



SC213LT-600LPB	
	600W
MFR Part #	PWS-605P-1H
AC Input	100 - 240V 60 - 50Hz 7.5 Amp maximum
DC Output	
+5V standby	3 Amp
+12V	49 Amp
+5V	18 Amp
+3.3V	15Amp
-12V	0.5 Amp



Appendix C

BPN-SAS-213LTQ Backplane Specifications

To avoid personal injury and property damage, carefully follow all the safety steps listed below when accessing your system or handling the components.

C-1 ESD Safety Guidelines

Electrostatic Discharge (ESD) can damage electronic components. To prevent damage to your system, it is important to handle it very carefully. The following measures are generally sufficient to protect your equipment from ESD.

- Use a grounded wrist strap designed to prevent static discharge.
- Touch a grounded metal object before removing a component from the antistatic bag.
- Handle the backplane by its edges only; do not touch its components, peripheral chips, memory modules or gold contacts.
- When handling chips or modules, avoid touching their pins.
- Put the card and peripherals back into their antistatic bags when not in use.

C-2 General Safety Guidelines

- Always disconnect power cables before installing or removing any components from the computer, including the backplane.
- Disconnect the power cable before installing or removing any cables from the backplane.
- Make sure that the backplane is securely and properly installed on the motherboard to prevent damage to the system due to power shortage.

C-3 A Note to Users

- All images and layouts shown in this user's guide are based upon the latest PCB revision available at the time of publishing. The card you have received may or may not look exactly the same as the graphics shown in this manual.

C-4 Introduction to the SAS-213LTQ Backplane

The BPN-SAS-213LTQ backplane has been designed to utilize the most up-to-date technology available, providing your system with reliable, high-quality performance.

This manual reflects BPN-SAS-213LTQ board revision 1.00, the most current release available at the time of publication. Always refer to the Supermicro Web site at www.supermicro.com for the latest updates, compatible parts and supported configurations.

Jumper Settings, Connectors and Pin Definitions

C-5 Front Connectors

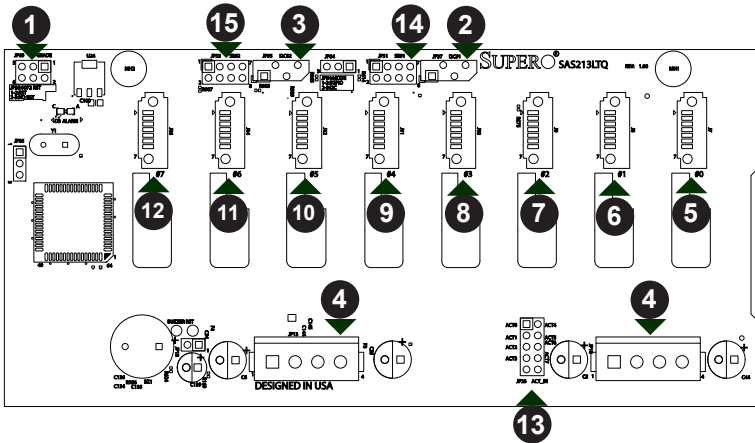

Figure C-1: Front Connectors

Front Connectors

- | | |
|--|-----------------------|
| 1. Upgrade Connectors: JP69 | 9. SAS/SATA #4: J11 |
| 2. I ² C Connector #1: JP37 | 10. SAS/SATA #5: J12 |
| 3. I ² C Connector #2: JP95 | 11. SAS/SATA #6: J14 |
| 4. Power Connectors (4-pin): JP10 and JP13 | 12. SAS/SATA #7: J16 |
| 5. SAS/SATA #0: J7 | 13. ACT_IN: JP26 |
| 6. SAS/SATA #1: J8 | 14. Sideband #1: JP51 |
| 7. SAS/SATA #2: J9 | 15. Sideband #2: JP53 |
| 8. SAS/SATA #3: J10 | |

C-6 Front Connector and Pin Definitions

1. Upgrade Connectors

The upgrade connector is designated JP69 and is used for manufacturer's diagnostic purposes only.

2. - 3. I²C Connectors

The I²C Connectors, designated JP37 and JP95, are used to monitor HDD activity and status. See the table on the right for pin definitions.

I ² C Connector Pin Definitions	
Pin#	Definition
1	Data
2	Ground
3	Clock
4	No Connection

4. Backplane Main Power Connectors

The 4-pin connectors, designated JP10, and JP13, provide power to the backplane. See the table on the right for pin definitions.

Backplane Main Power 4-Pin Connector	
Pin#	Definition
1	+12V
2 and 3	Ground
4	+5V

5. - 12. SAS/SATA Ports The SAS/SATA ports are used to connect the SAS drive cables. The eight SAS IN ports are designated #0 - #7.

13. ACT_IN:

The activity LED connector designated JP26, is used to indicate the activity status of each SAS drive. The activity LED connector is located on the front panel. For the activity LED connector to work properly, connect using a 10-pin LED cable. This is only used when the activity LED is not supported by the hard drive.

SAS Activity LED Header Pin Definitions			
Pin#	Definition	Pin#	Definition
1	ACT IN#0	6	ACT IN#4
2	ACT IN#1	7	ACT IN#5
3	ACT IN#2	8	ACT IN#6
4	ACT IN#3	9	ACT IN#7
5	Ground	X	Empty

14. - 15. Sideband #1 and #2:

The sideband headers are designated JP51 and JP53. For SES-2 to work properly, an 8-pin sideband cable must be connected. See the table on the right for pin definitions.

Sideband Headers			
Pin #	Definition	Pin #	Definition
2	Backplane Addressing (SB5)	1	Controller ID (SB6)
4	Reset (SB4)	3	GND (SB2)
6	GND (SB3)	5	SDA (SB1)
8	Backplane ID (SB7)	7	SCL (SB0)
10	No Connection	9	No Connection

C-7 Front Jumper Locations and Pin Definitions

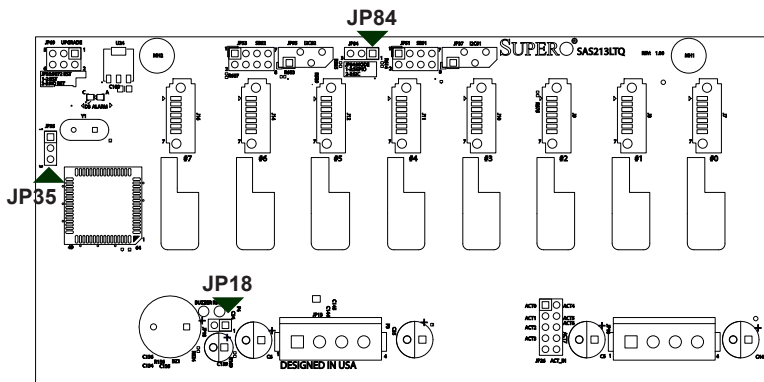
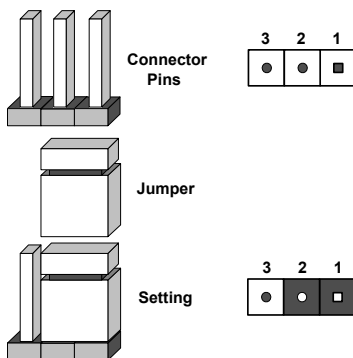

Figure C-2: Front Jumpers

Explanation of Jumpers

To modify the operation of the backplane, jumpers can be used to choose between optional settings. Jumpers create shorts between two pins to change the function of the connector. Pin 1 is identified with a square solder pad on the printed circuit board. Note: On two pin jumpers, "Closed" means the jumper is on and "Open" means the jumper is off the pins.



Jumper	1-2 Jumper Setting	2-3 Jumper Setting
JP35	9072 Reset	No Reset
Jumper	Open (Jumper Off)	Closed (Jumper On)
JP18	Buzzer Enabled*	Buzzer Disabled*

*The buzzer sound indicates that a condition requiring immediate attention has occurred.

The buzzer alarm is triggered by the following conditions:

1. Hard drive failure
2. System temperature over 45° Celsius.

I²C and SGPIO Modes and Jumper Settings

This backplane can utilize I²C or SGPIO. SGPIO is the default mode and can be used without making changes to your jumper. The following information details which jumper must be configured to use SGPIO mode or restore your backplane to I²C mode.

Jumper	1-2 Jumper Setting	2-3 Jumper Setting
JP84	SGPIO Mode (Default)	I ² C Mode

Front LED Indicators

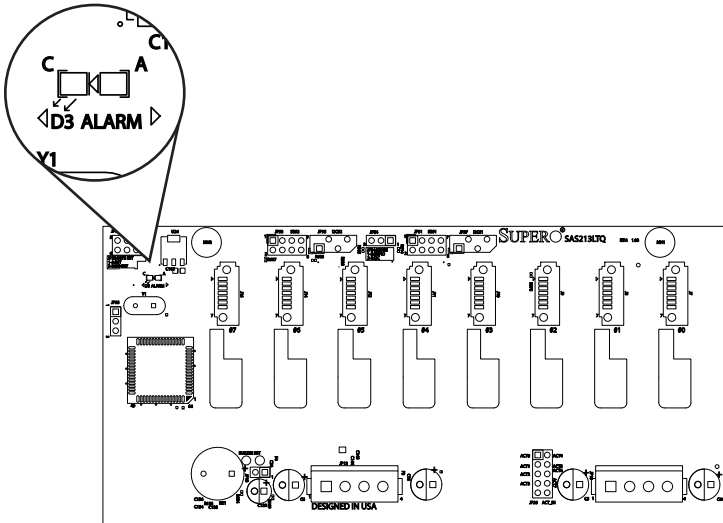

Figure C-3: Front LED

Front Panel LED		
LED	State	Specification
D3	On	Alarm indicating an overheat condition or drive failure

C-8 Rear Connectors and LED Indicators

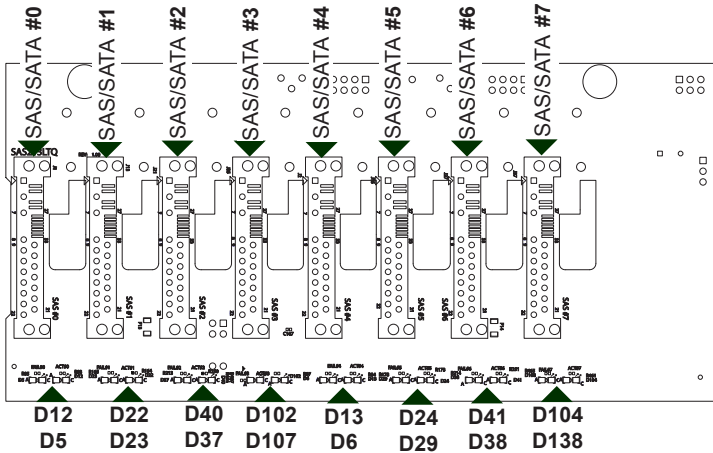

Figure C-4: Rear LEDs

Rear SAS/SATA Connectors	
Rear Connector	SAS Drive Number
SAS/SATA #0	SAS/SATA HDD #0
SAS/SATA #1	SAS/SATA HDD #1
SAS/SATA #2	SAS/SATA HDD #2
SAS/SATA #3	SAS/SATA HDD #3
SAS/SATA #4	SAS/SATA HDD #4
SAS/SATA #5	SAS/SATA HDD #5
SAS/SATA #6	SAS/SATA HDD #6
SAS/SATA #7	SAS/SATA HDD #7

Rear LED Indicators		
Rear LED	Hard Drive Activity (Blue LED)	Failure LED (Red LED)
SAS/SATA #0	D12	D5
SAS/SATA #1	D22	D23
SAS/SATA #2	D40	D37
SAS/SATA #3	D102	D107
SAS/SATA #4	D13	D6
SAS/SATA #5	D24	D29
SAS/SATA #6	D41	D38
SAS/SATA #7	D104	D108

Notes

Appendix D

BPN-SAS-213LT Backplane Specifications

To avoid personal injury and property damage, carefully follow all the safety steps listed below when accessing your system or handling the components.

D-1 ESD Safety Guidelines

Electrostatic Discharge (ESD) can damage electronic components. To prevent damage to your system, it is important to handle it very carefully. The following measures are generally sufficient to protect your equipment from ESD.

- Use a grounded wrist strap designed to prevent static discharge.
- Touch a grounded metal object before removing a component from the antistatic bag.
- Handle the backplane by its edges only; do not touch its components, peripheral chips, memory modules or gold contacts.
- When handling chips or modules, avoid touching their pins.
- Put the card and peripherals back into their antistatic bags when not in use.

D-2 General Safety Guidelines

- Always disconnect power cables before installing or removing any components from the computer, including the backplane.
- Disconnect the power cable before installing or removing any cables from the backplane.
- Make sure that the backplane is securely and properly installed on the motherboard to prevent damage to the system due to power shortage.

D-3 A Note to Users

All images and layouts shown in this user's guide are based upon the latest PCB revision available at the time of publishing. The card you have received may or may not look exactly the same as the graphics shown in this manual.

D-4 Introduction to the SAS-213LT Backplane

The SAS-213LT backplane has been designed to utilize the most up-to-date technology available, providing your system with reliable, high-quality performance.

This manual reflects SAS-213LT board revision 1.00, the most current release available at the time of publication. Always refer to the Supermicro Web site at www.supermicro.com for the latest updates, compatible parts and supported configurations

D-5 Front Connectors

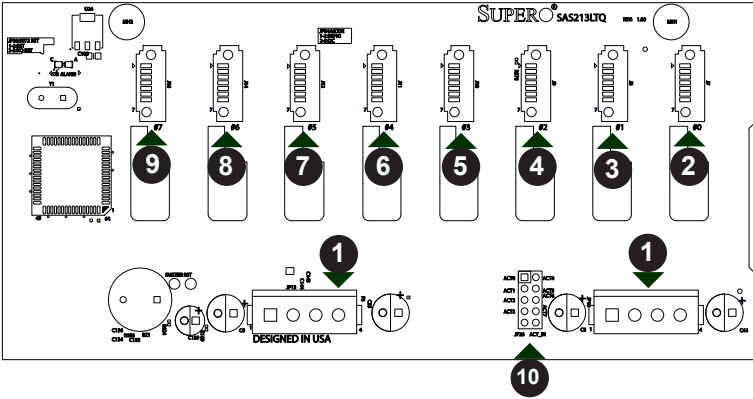

Figure D-1. Front Connectors

Front Connectors

- | | |
|--|---------------------|
| 1. Power Connectors (4-pin): JP10 and JP13 | 6. SAS/SATA #4: J11 |
| 2. SAS/SATA #0: J7 | 7. SAS/SATA #5: J12 |
| 3. SAS/SATA #1: J8 | 8. SAS/SATA #6: J14 |
| 4. SAS/SATA #2: J9 | 9. SAS/SATA #7: J16 |
| 5. SAS/SATA #3: J10 | 10. ACT_IN: JP26 |

D-6 Front Connector and Pin Definitions

1. Backplane Main Power Connectors

The 4-pin connectors, designated JP10, and JP13, provide power to the backplane. See the table on the right for pin definitions.

Backplane Main Power 4-Pin Connector	
Pin#	Definition
1	+12V
2 and 3	Ground
4	+5V

2. - 9. SAS/SATA Ports The SAS/SATA ports are used to connect the SAS drive cables. The eight SAS IN ports are designated #0 - #7.

10. ACT_IN:

The activity LED connector designated JP26, is used to indicate the activity status of each SAS drive. The activity LED connector is located on the front panel. For the activity LED connector to work properly, connect using a 10-pin LED cable. This is only used when the activity LED is not supported by the hard drive.

SAS Activity LED Header Pin Definitions			
Pin#	Definition	Pin#	Definition
1	ACT IN#0	6	ACT IN#4
2	ACT IN#1	7	ACT IN#5
3	ACT IN#2	8	ACT IN#6
4	ACT IN#3	9	ACT IN#7
5	Ground	X	Empty

D-7 Rear Connectors and LED Indicators

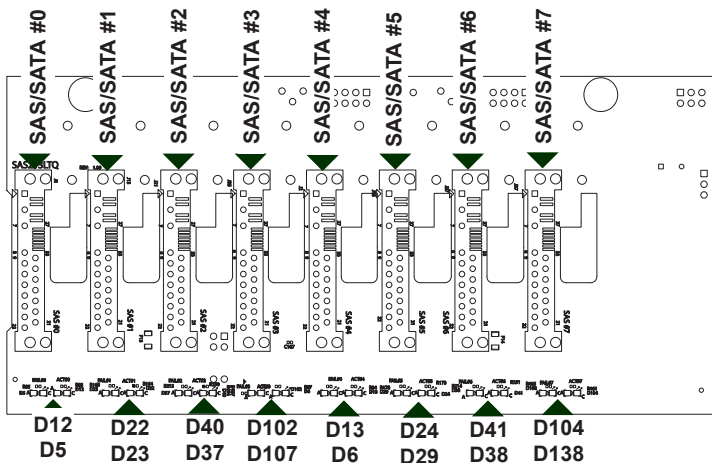

Figure D-2. Rear LEDs

Rear SAS/SATA Connectors	
Rear Connector	SAS Drive Number
SAS/SATA #0	SAS/SATA HDD #0
SAS/SATA #1	SAS/SATA HDD #1
SAS/SATA #2	SAS/SATA HDD #2
SAS/SATA #3	SAS/SATA HDD #3
SAS/SATA #4	SAS/SATA HDD #4
SAS/SATA #5	SAS/SATA HDD #5
SAS/SATA #6	SAS/SATA HDD #6
SAS/SATA #7	SAS/SATA HDD #7

Rear LED Indicators	
Rear LED	Hard Drive Activity (Blue LED)
SAS/SATA #0	D12
SAS/SATA #1	D22
SAS/SATA #2	D40
SAS/SATA #3	D102
SAS/SATA #4	D13
SAS/SATA #5	D24
SAS/SATA #6	D41
SAS/SATA #7	D104

Disclaimer (cont.)

The products sold by Supermicro are not intended for and will not be used in life support systems, medical equipment, nuclear facilities or systems, aircraft, aircraft devices, aircraft/emergency communication devices or other critical systems whose failure to perform be reasonably expected to result in significant injury or loss of life or catastrophic property damage. Accordingly, Supermicro disclaims any and all liability, and should buyer use or sell such products for use in such ultra-hazardous applications, it does so entirely at its own risk. Furthermore, buyer agrees to fully indemnify, defend and hold Supermicro harmless for and against any and all claims, demands, actions, litigation, and proceedings of any kind arising out of or related to such ultra-hazardous use or sale.