

SUPER[®]

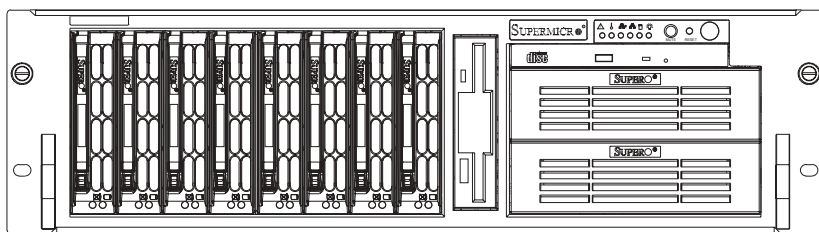

SC832/SC833 CHASSIS USER'S GUIDE

1.0

The information in this User's Guide has been carefully reviewed and is believed to be accurate. The vendor assumes no responsibility for any inaccuracies that may be contained in this document, makes no commitment to update or to keep current the information in this manual, or to notify any person or organization of the updates. **Please Note: For the most up-to-date version of this manual, please see our web site at www.supermicro.com.**

SUPERMICRO COMPUTER reserves the right to make changes to the product described in this manual at any time and without notice. This product, including software, if any, and documentation may not, in whole or in part, be copied, photocopied, reproduced, translated or reduced to any medium or machine without prior written consent.

IN NO EVENT WILL SUPERMICRO COMPUTER BE LIABLE FOR DIRECT, INDIRECT, SPECIAL, INCIDENTAL, OR CONSEQUENTIAL DAMAGES ARISING FROM THE USE OR INABILITY TO USE THIS PRODUCT OR DOCUMENTATION, EVEN IF ADVISED OF THE POSSIBILITY OF SUCH DAMAGES. IN PARTICULAR, THE VENDOR SHALL NOT HAVE LIABILITY FOR ANY HARDWARE, SOFTWARE, OR DATA STORED OR USED WITH THE PRODUCT, INCLUDING THE COSTS OF REPAIRING, REPLACING, INTEGRATING, INSTALLING OR RECOVERING SUCH HARDWARE, SOFTWARE, OR DATA.

Any disputes arising between manufacturer and customer shall be governed by the laws of Santa Clara County in the State of California, USA. The State of California, County of Santa Clara shall be the exclusive venue for the resolution of any such disputes. Supermicro's total liability for all claims will not exceed the price paid for the hardware product.

Unless you request and receive written permission from SUPER MICRO COMPUTER, you may not copy any part of this document.

Information in this document is subject to change without notice. Other products and companies referred to herein are trademarks or registered trademarks of their respective companies or mark holders.

Copyright © 2004 by SUPER MICRO COMPUTER INC.
All rights reserved.

Printed in the United States of America

Table of Contents

Chapter 1: Safety Information and Technical Specifications	1-4
1-1. Electrical Safety Guidelines	1-4
1-2. General Safety Guidelines	1-5
1-3. ESD Safety Guidelines	1-6
1-4. Operation Safety Guidelines	1-6
1-5. Product Compliance Information	1-8
1-6. Packing List and the SC832/SC833 Specifications	1-9
Chapter 2: Chassis Description and Installation Procedures	2-1
2-1. Chassis Description	2-1
A. Contents of the Accessory Kit	2-1
B. Chassis Front View and the Front Control Panel	2-2
C. Chassis Rear View and the Back Panel	2-4
2-2. Chassis Installation	2-6
A. Important Safety Guidelines	2-6
B. Tools Needed	2-6
C. Accessing the SCA Drive Tray and Installing a HDD	2-7
D. Removing the Top Cover of the Chassis	2-8
E. Accessing the Front Chassis Fans	2-9
F. Accessing the Power Supply	2-10
G. Installing the Motherboard	2-12
H. Installing Chassis Rails	2-14
I. Rack Installation	2-16

Chapter 1-Safety Information and Technical Specifications

1-1 Electrical Safety Guidelines



Warning: *To avoid electrical shock, check the power cords as follows:*

Checking the Power Cords

- Use the exact type of power cords as required.
- Be sure to use power cord(s) that came with safety certifications.
- The power cord(s) must be compliant with the AC voltage requirements in your region.
- The power cord plug cap must have an electrical current rating that is at least 125% of the electrical current rating of this product.
- The power cord plug cap that plugs into the AC receptacle on the power supply must be an IEC 320, sheet C13, type female connector.
- Be sure to disconnect the power supply before accessing the SC832/SC833 or its components.
- Plug the Power cord(s) into a socket that is properly grounded before turning on the power.



Warning: *Follow the guidelines below to avoid possible damages to the system or injury to yourself:*

General Electrical Safety Guidelines

- Be aware of the locations of the power switches on the chassis and in the room, so you can disconnect the power supply if an accident occurs.
- Take extra precautionary measures when working with high voltage components. It is not recommended to work alone.
- Before removing or installing main system components, be sure to disconnect the power first. Turn off the system before you disconnect the PS.
- Use only one hand when working with powered-on electrical equipment to avoid possible electrical shock.

- Use rubber mats specifically designed as electrical insulators when working with computer systems.
- The power supply or power cord must include a grounding plug and must be plugged into grounded outlets.
- Motherboard Battery: CAUTION - Make sure not to install the onboard battery upside down to avoid possible explosion. Make sure that the positive side should be facing up on the motherboard. This battery must be replaced only with the same or an equivalent type recommended by the manufacturer. Dispose of used batteries according to the manufacturer's instructions.
- CD-ROM Laser: CAUTION - Do not open the enclosures of power supplies or CD ROM to avoid injury.

1-2 General Safety Guidelines



Warning: Follow these rules to ensure general safety:

Keep the area around the SC832/SC833 clean and free of clutter.

- To avoid injuries to the back, be sure to use your leg muscles, keep your back straight, and bend your knees, when lifting the system.
- After removing the components or chassis covers from the system, place them on a table for safeguard.
- Avoid wearing loose clothing to preventing it from coming into contact with
- Be sure to remove any jewelry or metal objects before working on the chassis to avoid short circuits should these objects come into contact with power circuits.
- After accessing the interior of the chassis, be sure to close the chassis with chassis covers and secure the chassis to the racks with screws.

1-3 ESD Safety Guidelines



Electric Static Discharge (ESD) can damage electronic components. To prevent damage to your system board, it is important to handle it very carefully. The following measures are generally sufficient to protect your equipment from ESD.

- Use a grounded wrist strap designed to prevent static discharge.
- Keep all components and printed circuit boards (PCBs) in their antistatic bags until ready for use.
- Touch a grounded metal object before removing the board from the antistatic bag.
- Do not let components or PCBs come into contact with your clothing, which may retain a charge even if you are wearing a wrist strap.
- Touch a grounded metal object before removing the board from the antistatic bag.
- Handle a board by its edges only; do not touch its components, peripheral chips, memory modules or contacts.
- When handling chips or modules, avoid touching their pins.
- Put the motherboard and peripherals back into their antistatic bags when not in use.
- For grounding purposes, make sure your computer chassis provides excellent conductivity between the power supply, the case, the mounting fasteners and the motherboard.

1-4 Operation Safety Guidelines



Warning: For proper cooling, make sure to install all chassis covers before turning on the system. If this rule is not strictly followed, warranty may become void. Do not open the casing of a power supply. Power supplies can only be accessed and serviced by a qualified technician of the manufacturer.



To avoid personal injury and property damage, please carefully follow all the safety steps listed below:

Before accessing the chassis:

1. Turn off all peripheral devices connected to the SC832/SC833.
2. Press the power button to power off the system.
3. Unplug all power cords from the system or the wall outlets.
4. Disconnect all the cables and label the cables for easy identification.
5. Use a grounded wrist strap designed to prevent static discharge when handling components.

Removing the chassis covers:

After completing the above steps, you can remove the covers and install components/peripheral devices into the chassis as described in Chapter 2.

1. Unlock and remove the screws and fasteners to remove the cover or components.
2. Save all the screws and fasteners for later use. (If necessary, label these screws or fasteners for easy identification.)
3. Follow the instruction given in Chapter 3 to remove the chassis covers.

Reinstalling the chassis covers:

To maintain proper system cooling and airflow, do not operate the system without installing all chassis covers back to the chassis. To reinstall the chassis covers, please follow the steps listed below:

1. Make sure that all components and devices are securely fastened on the chassis and there are no loose parts/screws inside the chassis.
2. Make sure that all cables are properly connected to the connectors and ports.
3. Use the original screws or fasteners to install the covers to the chassis.
4. Be sure to lock to the chassis or the system to prevent unauthorized access.
5. For proper cooling, enclose the chassis with covers before operating the system.

Before installing the chassis into a rack:

1. Make sure that the rack is securely anchored onto a unmovable surface or structure before installing the chassis into the rack.
2. Unplug the power cord(s) of the rack before installing the chassis into the rack.
3. Make sure that the system is adequately supported. Make sure that all the components are securely fastened to the chassis to prevent components falling off from the chassis.
4. Be sure to install an AC Power Disconnect for the entire rack assembly and this Power Disconnect must be clearly marked.
5. The rack assembly shall be properly grounded to avoid electric shock.
6. The rack assembly must provide sufficient airflow to the chassis for proper cooling.

1-5 Product Compliance Information

The SC832/SC833 Chassis is compliant with the following safety standards/requirements:

Product Safety

- *Canada/USA--UL60 950-CSA60 950
- *European Union--EN 60 950
- *International--IEC 60 950

Electromagnetic Compatibility (EMC)-Emissions

- *European Union--EN55022: 1994
- *International--CISPR 22
- *USA--Title 47 CFR, Part 15

Electromagnetic Compatibility-Immunity

- *European Union--EN55024: 1998
- *International--CISPR 24

Power Line Harmonics/Voltage Flicker

- *European Union--EN61000-3-2/EN61000-3-3
- *International--IEC61000-3-2

1-6 Packing List and the SC832/SC833 Specifications

A. The SC832/SC833 chassis contains the following:

The SC832 chassis:

Component	Quantity	Part Number
SCA 1" Drive Trays	8	CSE-PT39(B)
92mm Hot-Swap Chassis Fan	4	FAN-0063
80mm Rear Chassis fan	Optional	FAN-0062
2+1 Triple Redundant 760W Power Supply	3	PWS-0050M (*760W)
Power Supply Power Distributor	1	CSE-PT833-PD382 (*760W)
550W Power Supply	1	PWS-0047 (*550W)
8-port SATA Backplane (*SC832T Only)	1	CSE-SATA-833
8-port SCSI Backplane (*SC832S Only)	1	CSE-SCA-833S
Floppy Drive	1	FPD-TEAC(B)
CD ROM Drive	Optional	CDM-TEAC-24(B)

The SC833 chassis:

Component	Quantity	Part Number
SCA 1" Drive Trays	8	CSE-PT39(B)
92mm Hot-Swap Chassis Fan	4	FAN-0064
80mm Rear Chassis fan	2	FAN-0062
Fan Shroud Sets	1	CSE-PT44
	1	CSE-PT45
2+1 Triple Redundant 760W Power Supply	3	PWS-0050M (*760W)
Power Supply Power Distributor	1	CSE-PT833-PD382 (*760W)
550W Power Supply	1	PWS-0047 (*550W)
8-port SATA Backplane (*SC833T Only)	1	CSE-SATA-833
8-port SCSI Backplane (*SC833S Only)	1	CSE-SCA-833S
Floppy Drive	1	FPD-TEAC(B)
CD ROM Drive	Optional	CDM-TEAC-24(B)

B. The Accessory Box and the Rail Packaging contain the following:

The Accessory box contains the following:

Component	Quantity
AC Power Cords	3 (*760W)
	1 (*550W)
Motherboard Screws and Standoffs	1 set
HDD Screws	1 set
Wrench	1

C. The Rail Packaging contains the following:

Rail Packaging contains:

Component	Quantity
Rack Rail Assembly	2 sets
Front Brackets for Mounting Rack Rail	2
Rear Brackets for Mounting Rack Rail	2
Mounting Screws	1 set

D. The Power Supply Specifications of the SC832/SC833

Power supply spec	760W series	550W Series
Mfr. model#	3 x SP382-TS	SP550
Mfr. part #	3 x PWS-0050M	PWS-0047
Rated AC input voltage	100-240V AC	100-240V AC
Rated input frequency	50-60 Hz	50-60 Hz
Rated input current	14A (115V)	9A(115V)
	7A (230V)	4.5A(230V)
Rated output power	760W	550W
Maximum rated BTU	4350 BTUs/Hr	2910 BUTs/Hr
Nominal DC output		
+3.3V	36A	30A
+5V	36A	35A
+12V	50A combined	34A
-5V	n/a	0.8A
-12V	1A	1A
+5Vsb	3.5A	2A

(*Note: When connecting the 760W Power Supply to the Drive Backplane, be sure to use the connectors marked "PD" and "PG", colored in yellow/green stripes.)

E. The Serial ATA Back Panel (*SC832/SC833T Only)

E-1 Jumper Settings and Pin Definitions

	Jumpers	Default Settings	Notes
A	JP18	Open	Buzzer Reset (*Note Below)
B	JP25	1-2	Overheat Temperature at 50°C
C	JP26	Open	Common Act In and Act#0-#7 In
D	JP61	Closed	Fan #1 Enabled/Sense
E	JP62	Closed	Fan #2 Enabled/Sense
F	JP63	Closed	Fan #3 Enabled/Sense

(*Note: Press the button on the front panel once to disable the buzzer. If the buzzer has been disabled, please be sure to press the button once again to re-enable the buzzer.)

E-2 Jumper Setting Locations

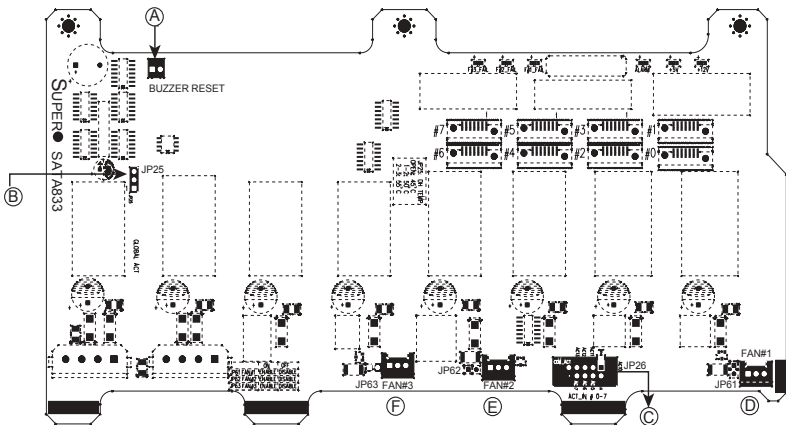

(*Note: When connecting the 760W Power Supply to the Drive Backplane, be sure to use the connectors marked "PD" and "PG", colored in yellow/green stripes.)

F. The SCSI Back Panel (*SC832/SC833S Only)

F-1 Jumper Settings and Pin Definitions

	Jumpers	Default Settings	Notes
A	JP19	Open	Buzzer Reset (*Note Below)
B	JP41	Closed	Fan #1 On/Sense
C	JP42	Closed	Fan #2 On/Sense
D	JP43	Closed	Fan #3 On/Sense

(*Note: Press the button on the front panel once to disable the buzzer. If the buzzer has been disabled, please be sure to press the button once again to re-enable the buzzer.)

F-2 Jumper Setting Locations

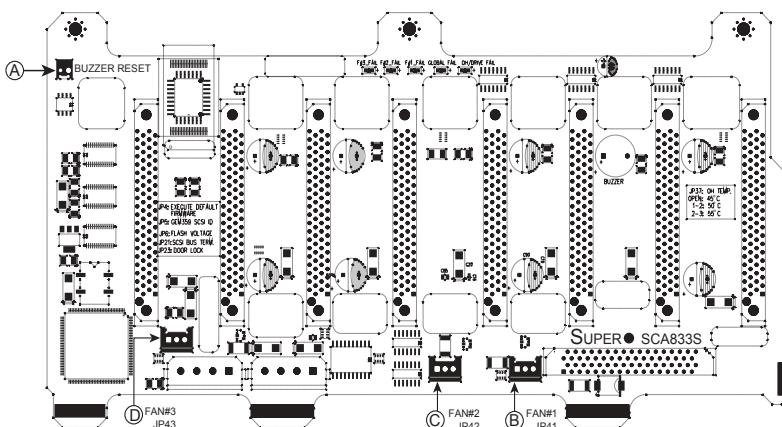

(*Note: When connecting the 760W Power Supply to the Drive Backplane, be sure to use the connectors marked "PD" and "PG", colored in yellow/green stripes.)

F-3 SCSI (Super) GEM Driver Installation (*for Windows OS)

(*Note: This driver is not necessary for other Operating Systems. If you have two SCA backplanes, you will need to install the driver twice.)

The driver is located on the Super Micro motherboard driver CD or is available for download from our FTP site: <ftp://ftp.supermicro.com/driver/Qlogic/>

Follow the procedure below to install this driver to your system.

Installing the driver:

- 1) Right click on "My Computer" and choose "Property".
- 2) Select "Hardware" tab and click on "Device Manager".
- 3) Open "Other Devices" or wherever "GEM318" is on.
- 4) Right click on this device and choose "Property".
- 5) Click on "Driver" tab and choose "Update Driver".
- 6) Click "Next" 2 times, uncheck both "Floppy disk drives" and "CD-ROM drives". Then, select the item- "Specify a location," and choose "Next".
- 7) Click on "Browse" and choose D drive or wherever Supermicro Setup CD is in.
- 8) Choose "Qlogic" folder and click on "Open".
- 9) System will automatically detect GEM318 and install the drive from this point on.

or,

- 1) Right click the "My Computer" icon on your desktop and choose Properties.
- 2) Click on the Hardware tab and click on "Device Manager" to bring up the list of system devices.
- 3) You may see one or two yellow question marks (?) that read QLogic GEM354 or GEM318 SCSI Processor Device. Right click on these, and choose to uninstall. If two such question marks are present, uninstall both.
- 4) Click on Action tab and choose "Scan for Hardware Changes". The Hardware Wizard program should start up. Click "Next".
- 5) At the first prompt, choose "Display a list of known device drivers for the device so that I can choose a specific driver" and click "Next".
- 6) Choose "Other Devices" and click Next.
- 7) Choose "Have Disk", and specify your floppy drive location in the options box. Then, click "Next".
- 8) Highlight "Enclosure Services Device" and click "Next".
- 9) Ignore the warning prompt by clicking "Yes".

Notes

Chapter 2: Chassis Description and Installation Instructions

2-1 Chassis Description

A. Contents of the Accessory Kit:

The following items are included in the Accessory Kit:

M/B



- A. Pan head w/ lock
6-32 x 4.5 mm [0.177]

HDD

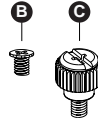

- B. Flat head 6-32 x 5 mm [0.197]
C. Thumb screw 6-32 x 5 mm [0.197]

DRIVE



- B. Flat head 6-32 x 5 mm [0.197]
D. Pan head 6-32 x 5 mm [0.197]
E. Round head M3 x 5 mm [0.197]

RAIL

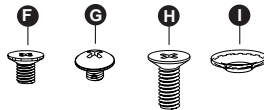

- F. Flat head M4 x 4 mm [0.157]
G. Round head M4 x 4 mm [0.157]
H. Flat head M5 x 12 mm [0.472]
I. Washer for M5

M/B STANDOFF

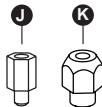

- J. M/B standoff, 6-32 to 6-32
K. M/B (CPU) standoff, M5 to 6-32

B. Chassis Front View and the Front Control Panel

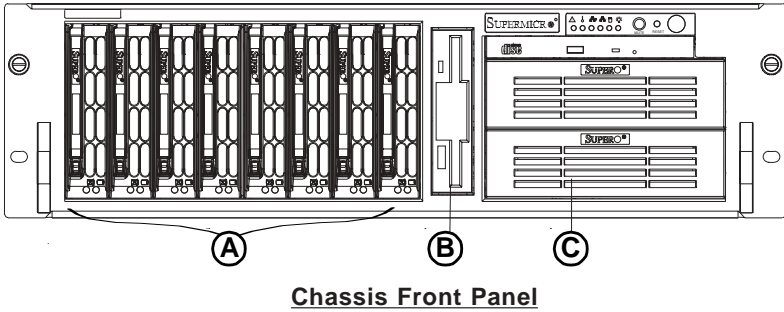

Front Panel I/O Device Definitions

- A. SCA Drive Trays(8)
- B. Floppy Disk(1)
- C. 5.25" Drive Bays(2)

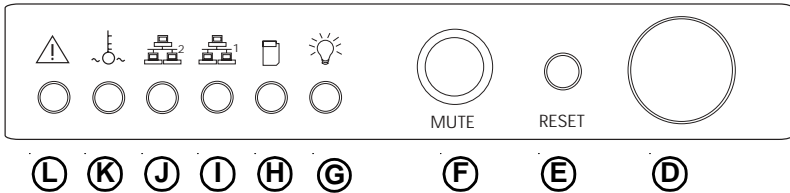

(*Note)

LED Panel

(*Note: After the Alarm goes off, please press the Alarm Reset button to reactivate the function.)

LED Button Definitions

- | | |
|------------------------|-------------------------------|
| D. Power Button | I. LAN1 |
| E. Reset | J. LAN2 |
| F. Alarm Reset (*Note) | K. Overheat |
| G. Power Indicator | L. System Alert/Power Failure |
| H. HDD Activity | |

LED Button Descriptions

LED Button	Color	Condition	Description
Power	Green	On	System On
		Off	System Off
HDD	Amber	Blink	HDD Activity
		Off	No Activity
LAN1 & LAN2	Green	On	Linked
		Blink	LAN Activity
		Off	Disconnected
Overheat	Red	On	System Overheat
		Off	System Normal
System Alert/ Power Failure	Red	On	1 or more PWR modules failure
		Off	System Normal

C. Chassis Rear View and the Back Panel

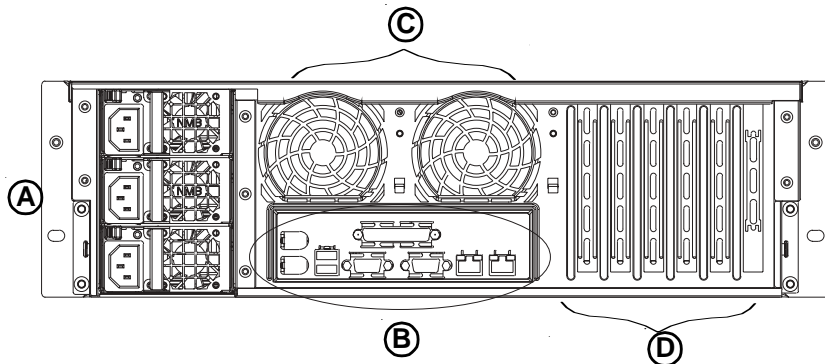

SC832/SC833 Chassis Rear View

Back Panel Devices

- A. Power Supply Modules (3) (*760W only)
- B. Back Panel I/O Ports
- C. Rear System Fan Slots(2)
- D. Full size PCI Expansion Slots (6)

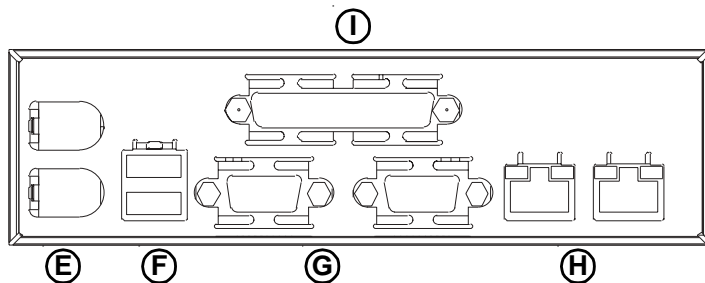

***I/O Back Panel**

Back Panel I/O Port Definitions

- E. Keyboard & Mouse
- F. USB Ports
- G. COM/Video Ports
- H. LAN1 & LAN2
- I. Parallel Port

(*Note: The actual I/O Configuration of your system might be different from the one shown above.)

Power Module LED Descriptions

Power Module LED	Color Condition	Description
	Green	Power Supply DC On
	Amber	Power Supply Standby
	Off	No AC Power to the system

2-2 Chassis Installation

A. Important Safety Guidelines



This product shall only be accessed, assembled and serviced by technically qualified personnel or technicians.

To avoid personal injury and property damage, please read all the information provided in Chapter 1, and carefully follow all the Safety Guidelines listed before accessing or servicing the SC832/SC833 or its components. For your convenience, some Safety Steps are also listed below:

Safety Steps

Before accessing the chassis:

1. Turn off all peripheral devices and turn off the power supply connected to the SC832/SC833.
2. Unplug all power cords from the system or the wall outlets.
3. Disconnect all the cables and label the cables for easy identification.
4. Use a grounded wrist strap designed to prevent static discharge when handling components.

Removing the chassis covers:

After completing the above steps, you can remove the chassis covers and install components and devices into the chassis as described in this chapter.

1. Unlock and remove the screws and fasteners to remove the cover or components.
2. Save all the screws and fasteners for later use. (If necessary, label these screws or fasteners for easy identification.)
3. Follow the instructions given in this chapter to remove the chassis covers.

B. Tools needed

1. Phillips Screw Driver
2. Antistatic Strap

C. Accessing the SCA Drive Tray and Installing a HDD

To install the SCA drive into the chassis, you need to first remove the SCA drive tray from the chassis.

Procedures

1. Press the release tab located on the drive tray door to release the drive tray from its locking position as shown below:

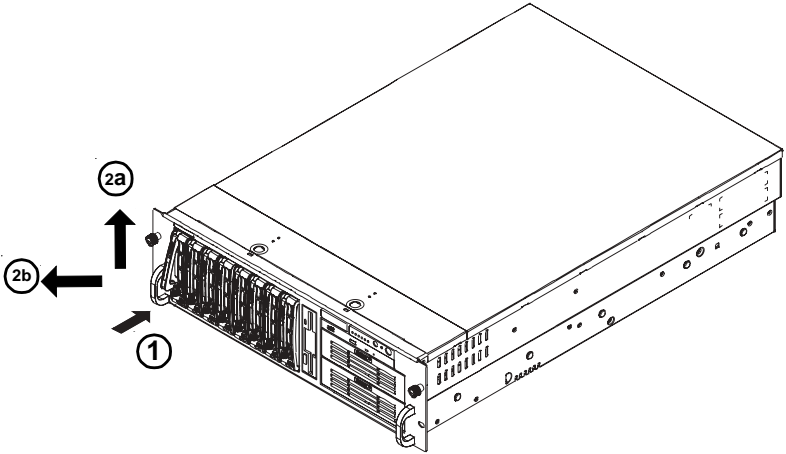

2. Pull the drive tray door upward and then pull the SCA drive tray out from the chassis

3. Mount a hard drive in the drive tray as shown below:

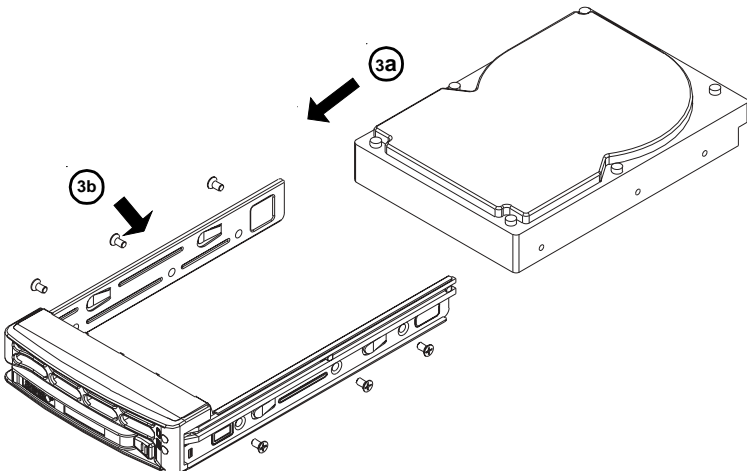

D. Removing the Top Cover of the SC832/SC833 Chassis

Before installing any components, replacing chassis fans or accessing the motherboard, you will first need to remove the top cover.

Procedures

1. Press the release tabs to release the cover from its locking position.

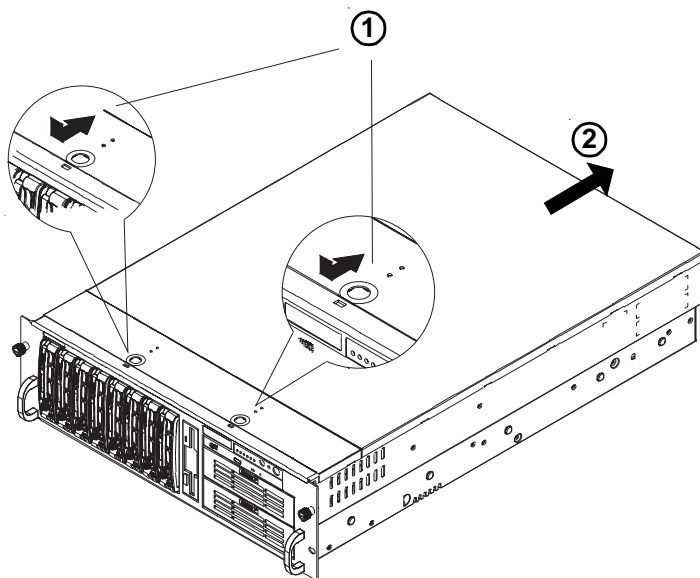

2. Once the top cover is released from its locking position, push the cover toward the rear side and slide it out from the chassis.

E. Accessing the Front Chassis Fans

Procedures

1. Press the release tab located on the left side of the front chassis fan (when facing the front side of the fan) to release the chassis fan from its locking position as shown in the picture below:

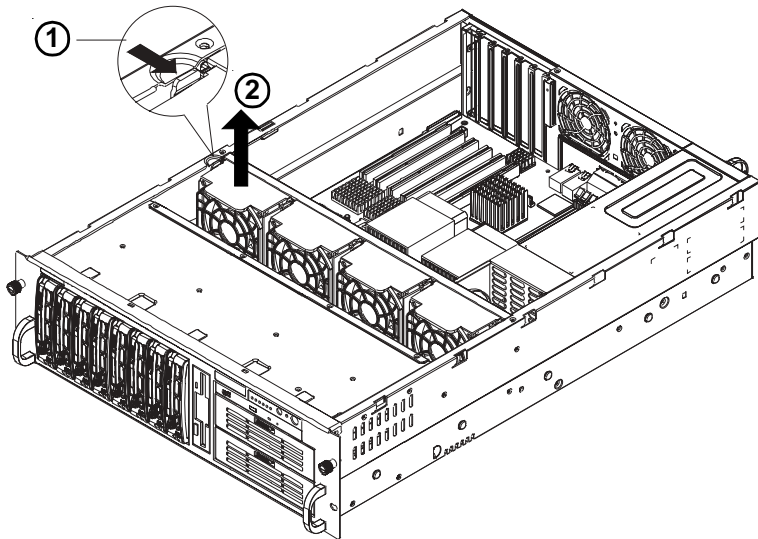

2. Once you've loosened the front chassis fan, you can pull the fan out.

F-1. Accessing the 760W Power Supply (*For Triple Redundant Power Supply-3xPWS-0050M)

(*Caution: Unplug the Power Cord before removing the Power Supply!!)

Procedures

1. Locate the release tab on the left side of the power supply.
2. Push the release tab to the right to release the power supply from its locking position as shown below:

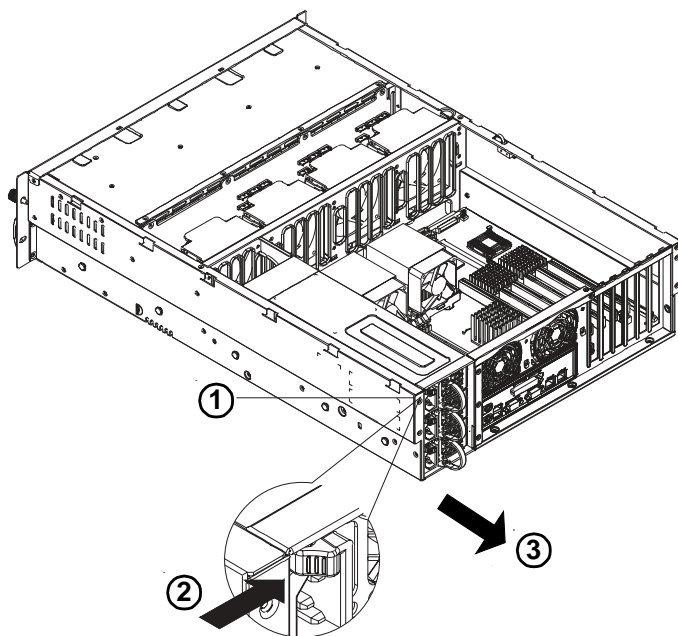

3. Once the power supply module is released from its locking position, remove it from the chassis.



Warning: *Do not open the casing of a power supply. Power supplies can only be accessed and serviced by a qualified technician from the manufacturer.*

F-2. Accessing the 550W-Power Supply (*For Single PWS-0047)

(*Caution: Unplug the Power Cord before removing the Power Supply!!)

Procedures

1. Unscrew the screws to remove the metal plate.
2. Remove the four screws from the power supply.
3. Pull the power supply out from its housing as shown in the picture:

(PWS-0047)

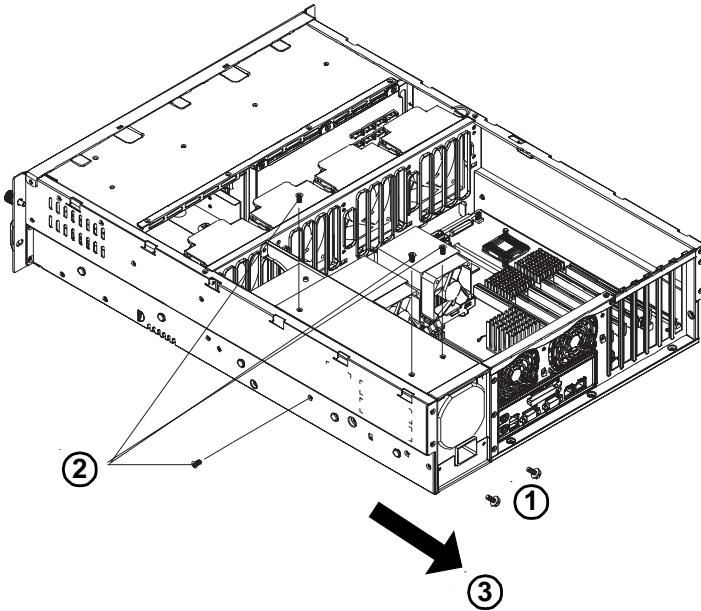

G. Installing the Motherboard

Be sure to disconnect the power supply before accessing or installing the motherboard into the chassis. However, you will need to, first, identify the CPU locations, and then, install the correct type of standoffs under the CPUs before installing the motherboard into the chassis. (Refer to Chapter 1 for Safety Guidelines.)

Procedures

1. Lay the chassis on a flat surface. Locate the CPU mounting holes on the chassis and install CPU standoffs on the chassis.

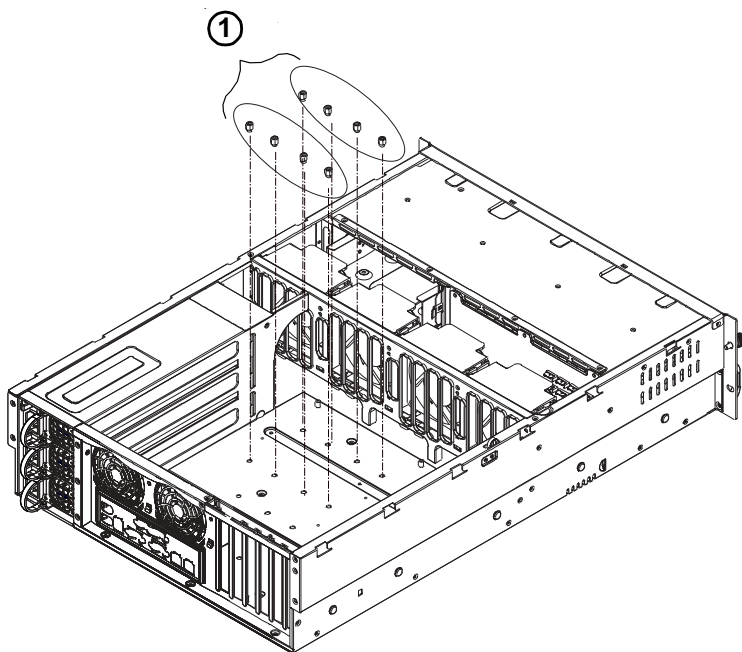

(****Note:** the motherboard shown above is for reference only!! The motherboard is not included in the SC832/SC833 shipping package.)

2. Install standoffs to all the remaining mounting holes on the motherboard. Then, lay the motherboard on the standoffs.

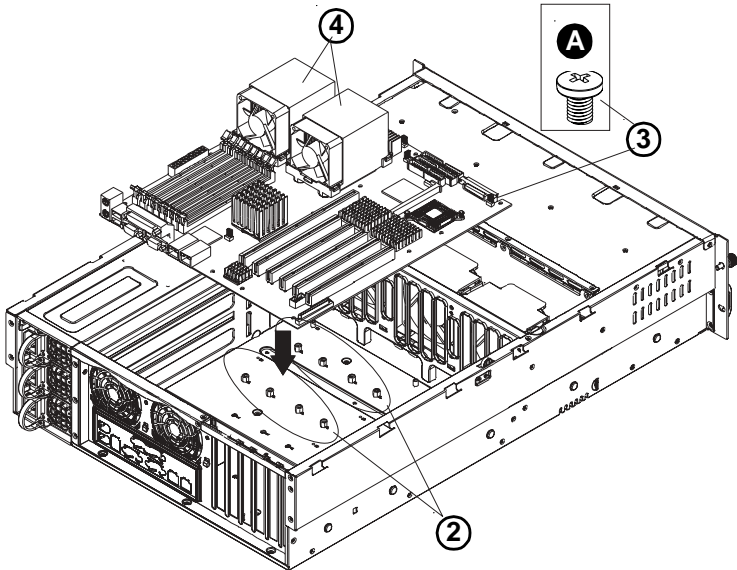

3. Secure the motherboard to the chassis with Type A(6-32) screws as shown above. (*Please refer to Page 2-1 MB kit for the Type A screw.)
4. Secure the CPU heatsink mechanism to the motherboard.

(****Note:** the CPU shown above is for reference only!! The motherboard is not included in the SC832/SC833 shipping package.)



Warning: *For proper cooling, please make sure that all the chassis covers are installed before you operate the system. Out of warranty damage can occur if this rule is not strictly followed.*

H. Installing Chassis Rails

Please make sure that the chassis covers and chassis rails are installed on the chassis before you install the chassis into the rack.



To avoid personal injury and property damage, please carefully follow all the safety steps listed below:

Before installing the Chassis rails:

1. Enclose the chassis with chassis covers.
2. Unplug the AC power cord(s).
3. Remove all external devices and connectors.

Procedures to Install Chassis Rails

1. Included in the shipping package are a pair of rail assemblies. In each rail assembly, locate the inner rail and the outer rail.
2. Press the locking tab to release the inner rail from its locking position and pull out the inner rail from the rail assembly. (*The inner rails are to be attached to the chassis and the outer rails are to be installed in the rack.)

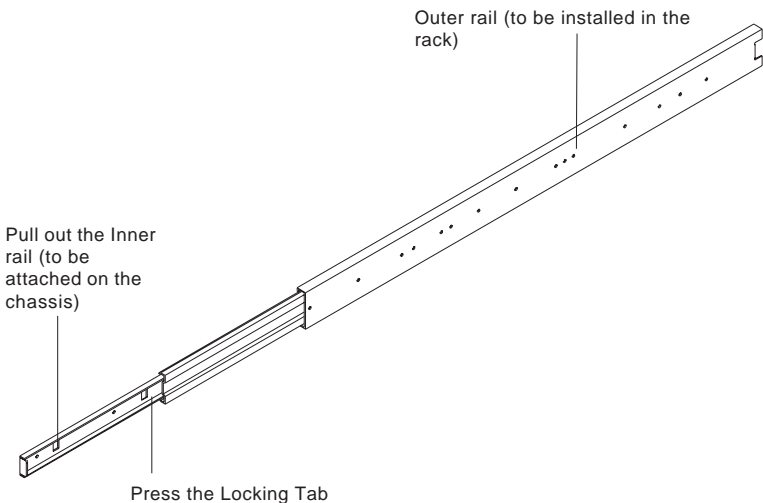

3. Locate the five rail buttons on each side of the chassis and locate the five corresponding holes on each of the inner rail.

(*Please note that one end of the hole is larger than the other end of the hole.)

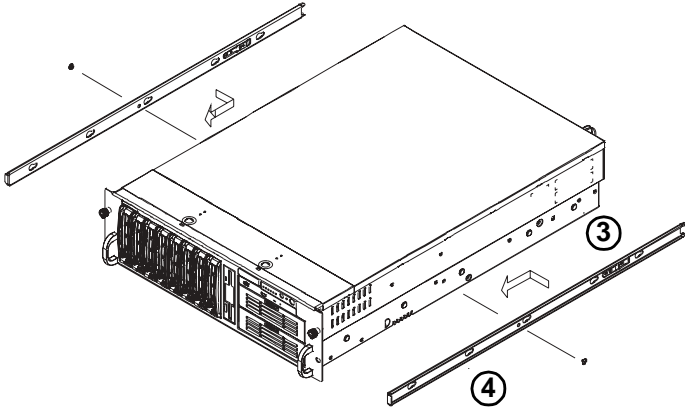

4. Align the larger end of each hole against its corresponding button. Once all aligned, push the holes toward their corresponding buttons and the rail is placed on the chassis.

5. Once the rail is placed on the chassis, pull the rail forward until the rail buttons lock in the small ends of the corresponding holes.

6. Secure the rail to the chassis with a Type G screw (Refer to Page 2-1 for the Type G screw.) Repeat the above steps to install other rail on the chassis.

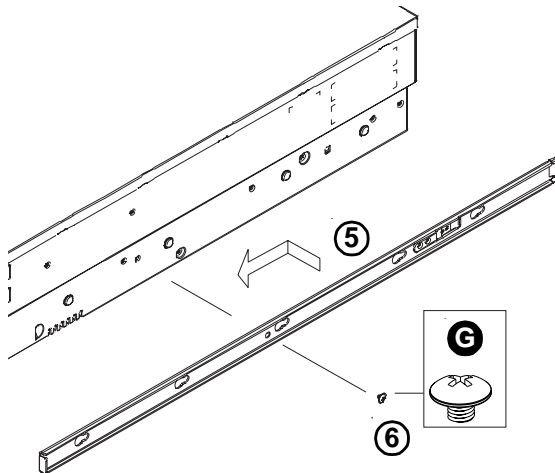

I. Rack Installation

After you have installed the inner rails on the chassis, you are ready to install the outer rails of rail assemblies to the rack.

(* The rails are designed to fit in the racks with the depth of 28" to 33".)

Procedures

1. In the package, locate a pair of front (-short) and rear (-long) brackets. Please note that the brackets are marked with Up/Front Arrows (-front) and Up/Rear arrows (-rear).
2. Secure the front (-short) bracket (marked with the Up/Front arrows) to the outer rail with two Type G screws.
3. Locate the two buttons on the outer rail and attach the rear (-long) bracket to it by sliding the opening of the rear rail through the button.
4. Measure the depth of your rack and adjust the length of the rails accordingly.
5. Repeat the same steps install the other outer rail on the chassis.
6. Secure both outer rail assemblies to the rack with Type H screws and Type I Washers.

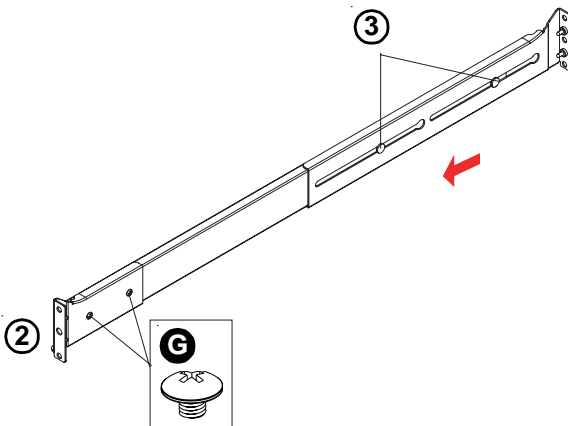

7. Slide the SC832/SC833 chassis into the rack as shown below:

(The SC832/SC833 may not slide into the rack smoothly or easily when installed the first time. However, some adjustment to the slide assemblies might be needed for easy installation.)

8. You will need to release the safety taps on both sides of the chassis in order to completely remove the chassis out of the rack.

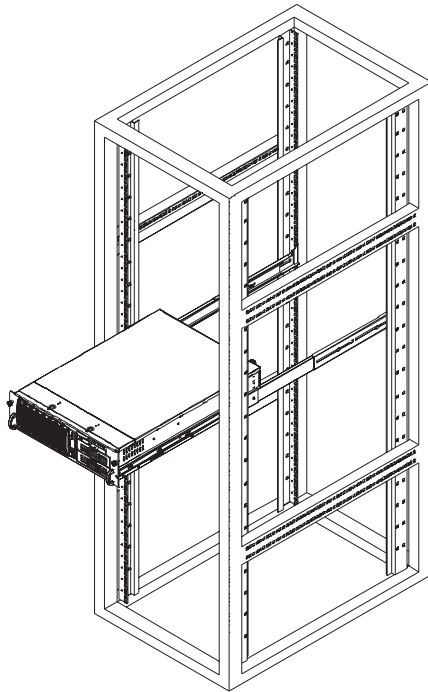

Notes