

SUPERO[®]

SUPER P4SS8
SUPER P4SSE

USER'S MANUAL

Revision 1.0

The information in this User's Manual has been carefully reviewed and is believed to be accurate. The vendor assumes no responsibility for any inaccuracies that may be contained in this document, makes no commitment to update or to keep current the information in this manual, or to notify any person or organization of the updates.

Please Note: For the most up-to-date version of this manual, please see our web site at www.supermicro.com.

SUPERMICRO COMPUTER reserves the right to make changes to the product described in this manual at any time and without notice. This product, including software, if any, and documentation may not, in whole or in part, be copied, photocopied, reproduced, translated or reduced to any medium or machine without prior written consent.

IN NO EVENT WILL SUPERMICRO COMPUTER BE LIABLE FOR DIRECT, INDIRECT, SPECIAL, INCIDENTAL, OR CONSEQUENTIAL DAMAGES ARISING FROM THE USE OR INABILITY TO USE THIS PRODUCT OR DOCUMENTATION, EVEN IF ADVISED OF THE POSSIBILITY OF SUCH DAMAGES. IN PARTICULAR, THE VENDOR SHALL NOT HAVE LIABILITY FOR ANY HARDWARE, SOFTWARE, OR DATA STORED OR USED WITH THE PRODUCT, INCLUDING THE COSTS OF REPAIRING, REPLACING, INTEGRATING, INSTALLING OR RECOVERING SUCH HARDWARE, SOFTWARE, OR DATA.

Any disputes arising between manufacturer and customer shall be governed by the laws of Santa Clara County in the State of California, USA. The State of California, County of Santa Clara shall be the exclusive venue for the resolution of any such disputes. Supermicro's total liability for all claims will not exceed the price paid for the hardware product.

Unless you request and receive written permission from SUPER MICRO COMPUTER, you may not copy any part of this document.

Information in this document is subject to change without notice. Other products and companies referred to herein are trademarks or registered trademarks of their respective companies or mark holders.

Copyright © 2002 by SUPER MICRO COMPUTER INC.
All rights reserved.

Printed in the United States of America

Preface

About This Manual

This manual is written for system integrators, PC technicians and knowledgeable PC users. It provides information for the installation and use of the SUPER P4SS8/P4SSE mainboard. The SUPER P4SS8/P4SSE supports single Intel® Xeon™ 1.8 - 2.8 GHz processors with a 512K L2 cache at a 400 MHz front side bus. Please refer to the support section of our web site (<http://www.supermicro.com/TechSupport.htm>) for a complete listing of supported processors. This product is intended to be professionally installed.

Manual Organization

Chapter 1 begins with a checklist of what should be included in your mainboard box, describes the features, specifications and performance of the motherboard and provides detailed information about the chipset.

Chapter 2 begins with instructions on handling static-sensitive devices. Read this chapter when you want to install the processor and DIMM memory modules and when mounting the mainboard in the chassis. Also refer to this chapter to connect the floppy and hard disk drives, SCSI drives, the IDE interfaces, the parallel and serial ports, the front control panel functions, the speaker and the keyboard.

If you encounter any problems, see **Chapter 3**, which describes troubleshooting procedures for the video, the memory and the setup configuration stored in CMOS. For quick reference, a general FAQ [Frequently Asked Questions] section is provided. Instructions are also included for contacting technical support. In addition, you can visit our web site at www.supermicro.com/techsupport.htm for more detailed information.

Chapter 4 includes an introduction to BIOS and provides detailed information on running the CMOS Setup utility.

Appendix A gives information on BIOS error beep codes.

Appendix B provides POST checkpoint codes.

Table of Contents

Preface

About This Manual	iii
Manual Organization	iii

Chapter 1: Introduction

1-1 Overview	1-1
Checklist	1-1
Contacting Supermicro	1-2
Super P4SS8 Image	1-4
Super P4SSE Image	1-5
Super P4SS8 Layout	1-6
Super P4SS8 Quick Reference	1-7
Super P4SSE Layout	1-8
Super P4SSE Quick Reference	1-9
Motherboard Features	1-10
ServerWorks GC - SL Chipset System Block Diagram	1-12
1-2 Chipset Overview	1-13
1-3 Special Features	1-13
ATI Graphics Controller	1-13
BIOS Recovery	1-13
Recovery from AC Power Loss	1-13
1-4 PC Health Monitoring	1-14
1-5 ACPI Features	1-15
1-6 Power Supply	1-17
1-7 Super I/O	1-17

Chapter 2: Installation

2-1 Static-Sensitive Devices	2-1
Precautions	2-1
Unpacking	2-1
2-2 PGA Processor and Heatsink Installation	2-2
2-3 Installing DIMMs	2-5
2-4 IO Ports/Control Panel Connectors	2-6
2-5 Connecting Cables	2-8
ATX Power Connection	2-8
PWR_SEC Connection	2-8
Power LED	2-8
HDD LED	2-8

L2 LED	2-9
L1 LED	2-9
Overheat LED	2-9
Power Fail LED	2-9
Reset	2-9
PWR_ON	2-10
Universal Serial Bus (USB0/1)	2-10
Extra Universal Serial Bus Connection (USB2/3)	2-10
Serial Ports	2-11
PS/2 Keyboard and Mouse Ports	2-11
Fan Headers	2-11
LAN (Ethernet) Ports	2-11
HD LED Indicator	2-12
Chassis Intrusion	2-12
Power LED	2-12
Wake-On-LAN	2-12
SMB	2-12
External Speaker Header	2-13
2-6 Onboard Indicators	2-13
LAN Port LEDs	2-13
CR1 LED	2-13
2-7 DIP Switch Settings	2-14
DIP Switch 1: Processor Speed	2-14
2-8 Jumper Settings	2-15
Explanation of Jumpers	2-15
CMOS Clear	2-15
VGA Enable/Disable	2-16
Fan Status Select	2-16
Watch Dog Enable/Disable	2-16
Mb LAN Enable/Disable	2-16
Gb Enable/Disable	2-17
SCSI Termination Enable/Disable	2-17
SCSI Enable/Disable	2-17
2-9 Parallel Port, Floppy/Hard Disk Drive and SCSI Connections	2-18
Parallel Port Connector	2-18
Floppy Connector	2-19
IDE Connectors	2-19
Ultra320 SCSI Connector	2-20

2-10 Installing Software Drivers 2-21

Chapter 3: Troubleshooting

3-1 Troubleshooting Procedures 3-1

- Before Power On 3-1
- No Power 3-1
- No Video 3-1
- Memory Errors 3-2
- Losing the System's Setup Configuration 3-2

3-2 Technical Support Procedures 3-2

3-3 Frequently Asked Questions 3-3

3-4 Returning Merchandise for Service 3-5

Chapter 4: BIOS

4-1 Introduction 4-1

4-2 BIOS Features 4-2

4-3 Running Setup 4-2

- Main BIOS Setup Menu 4-3

4-4 Advanced BIOS Setup 4-4

4-5 Chipset Setup 4-15

4-6 PCI / PnP Setup 4-18

4-7 Power Setup 4-20

4-8 Boot Setup 4-22

4-9 Security Setup 4-24

4-10 Exit Setup 4-26

Appendices:

Appendix A: BIOS Error Beep Codes A-1

Appendix B: BIOS POST Codes B-1

Chapter 1

Introduction

1-1 Overview

Checklist

Congratulations on purchasing your computer motherboard from an acknowledged leader in the industry. Supermicro boards are designed with the utmost attention to detail to provide you with the highest standards in quality and performance.

Please check that the following items have all been included with your motherboard. If anything listed here is damaged or missing, contact your retailer.

One (1) Supermicro Mainboard

One (1) ribbon cable for IDE devices

One (1) floppy ribbon cable

One (1) I/O backpanel shield

One (1) Supermicro CD or diskettes containing drivers and utilities

One (1) User's/BIOS Manual

One (1) fan/heatsink assembly (OEM only)

One (1) set of heatsink retention clips

SCSI Accessories (P4SS8 only)

One (1) 68-pin LVD SCSI cable (OEM only)

One (1) set of SCSI drivers (included on CD-ROM)

One (1) SCSI manual (PDF file included on CD-ROM)

Contacting Supermicro

Headquarters

Address: SuperMicro Computer, Inc.
980 Rock Ave.
San Jose, CA 95131 U.S.A.

Tel: +1 (408) 503-8000

Fax: +1 (408) 503-8008

Email: marketing@supermicro.com (General Information)
support@supermicro.com (Technical Support)

Web Site: www.supermicro.com

Europe

Address: SuperMicro Computer B.V.
Het Sterrenbeeld 28, 5215 ML
's-Hertogenbosch, The Netherlands

Tel: +31 (0) 73-6400390

Fax: +31 (0) 73-6416525

Email: sales@supermicro.nl (General Information)
support@supermicro.nl (Technical Support)
rma@supermicro.nl (Customer Support)

Asia-Pacific

Address: SuperMicro, Taiwan
D5, 4F, No. 16 Chien-Ba Road
Chung-Ho 235, Taipei Hsien, Taiwan, R.O.C.

Tel: +886-(2) 8226-3990

Fax: +886-(2) 8226-3991

Web Site: www.supermicro.com.tw

Technical Support:

Email: support@supermicro.com.tw

Tel: 886-2-8226-3990, ext.132 or 139

Notes

Figure 1-1. SUPER P4SS8 Image

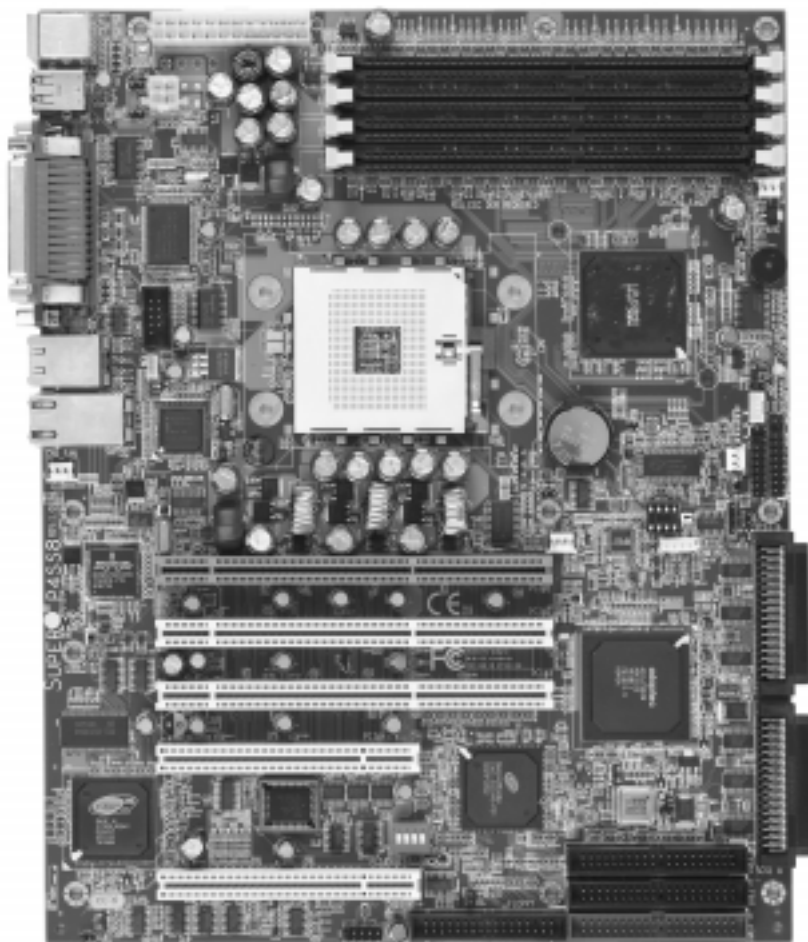

Figure 1-2. SUPER P4SSE Image

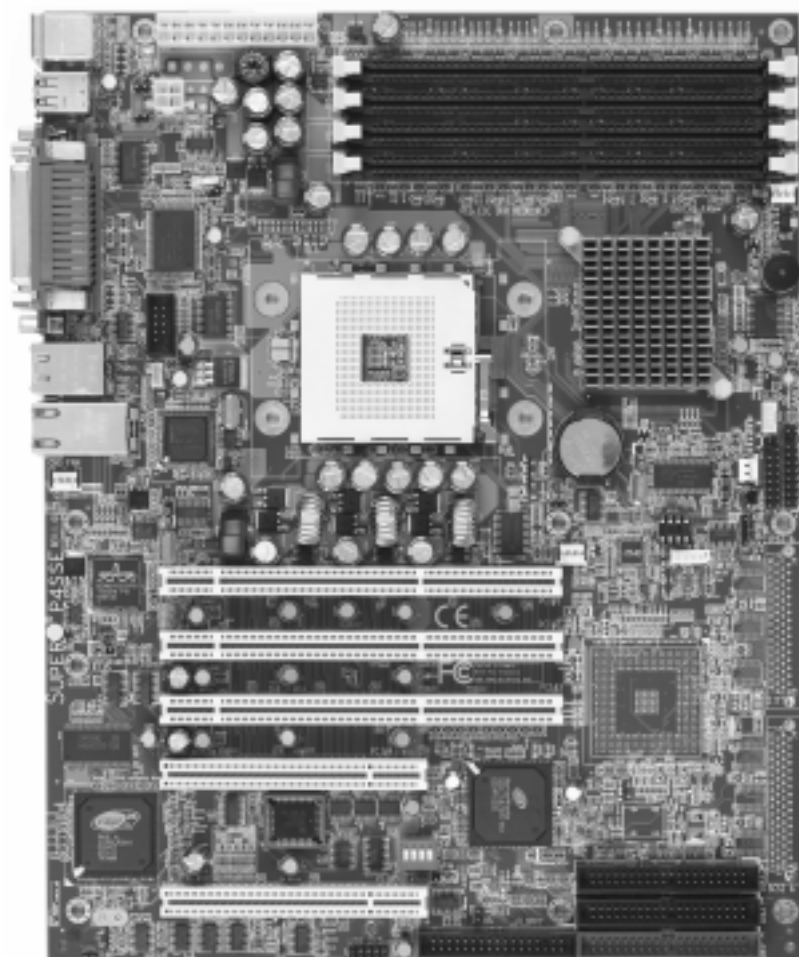
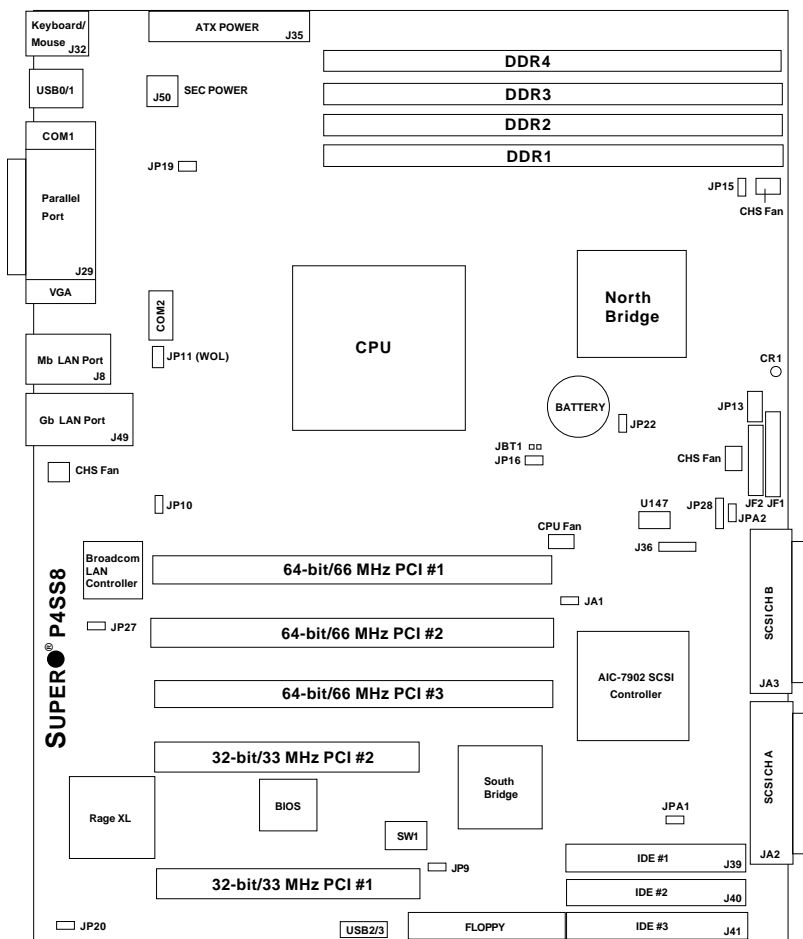

Figure 1-3. SUPER P4SS8 Layout
(not drawn to scale)



Note: DIP Switch 1 sets the processor speed (see Section 2-7).
Jumpers not noted are for test purposes only.

Also see Chapter 2 for the locations of the I/O ports and Front Control Panel (JF1/JF2) connectors and for details on jumper settings and pin definitions.

P4SS8 Quick Reference

<u>Jumper</u>	<u>Description</u>	<u>Default Setting</u>
JA1	SCSI Enable/Disable	Pins 1-2 (Enabled)
JBT1	CMOS Clear	See Chapter 2
JPA1/A2	SCSI Channel A/B Termination	Off (Terminated)
JP9	VGA Enable/Disable	Pins 1-2 (Enabled)
JP10	Mb LAN Enable/Disable	Pins 1-2 (Enabled)
JP15	Fan Status Select	Open (OH Condition)
JP19	Watch Dog Enable/Disable	Open (Disabled)
JP20	Main Power Override	Off (Normal)
JP22	System Bus Speed Select	Pins 1-2 (Auto)
JP27	Gb LAN Enable/Disable	Pins 1-2 (Enabled)

<u>Switch</u>	<u>Description</u>
DIP Switch 1	Processor Speed

<u>Connector</u>	<u>Description</u>
COM1/COM2	COM1/COM2 Serial Ports
CPU/CHS/OH FAN	CPU/Chassis/Overheat Fan Headers
CPU	CPU Socket
DDR1-DDR4	Memory (SDRAM) Slots
JA2/JA3	Ultra320 LVD SCSI CH A/B Connector
JF1	Front Control Panel Headers
JF2	ChInt/NMI/HD LED/PWR LED Headers
JP11	Wake-on-LAN Header
JP16	Chassis Intrusion Header
JP28	External Speaker Header
J7	VGA Display (Monitor) Port
J8	Mb Ethernet Port
J28	Floppy Disk Drive Connector
J29	Parallel Printer Port
J32	PS/2 Keyboard/Mouse Ports
J35	Primary ATX Power Connector
J36	SMB Header
J39/J40/J41	IDE1/2/3 Hard Disk Drive Connector
J49	Gb Ethernet Port
J50	Secondary ATX Power Connector
USB0/1	Universal Serial Bus Ports
USB2/3	Universal Serial Bus Headers
U147	POST Messaging Voice BIOS (future option)

Figure 1-4. SUPER P4SSE Layout
(not drawn to scale)

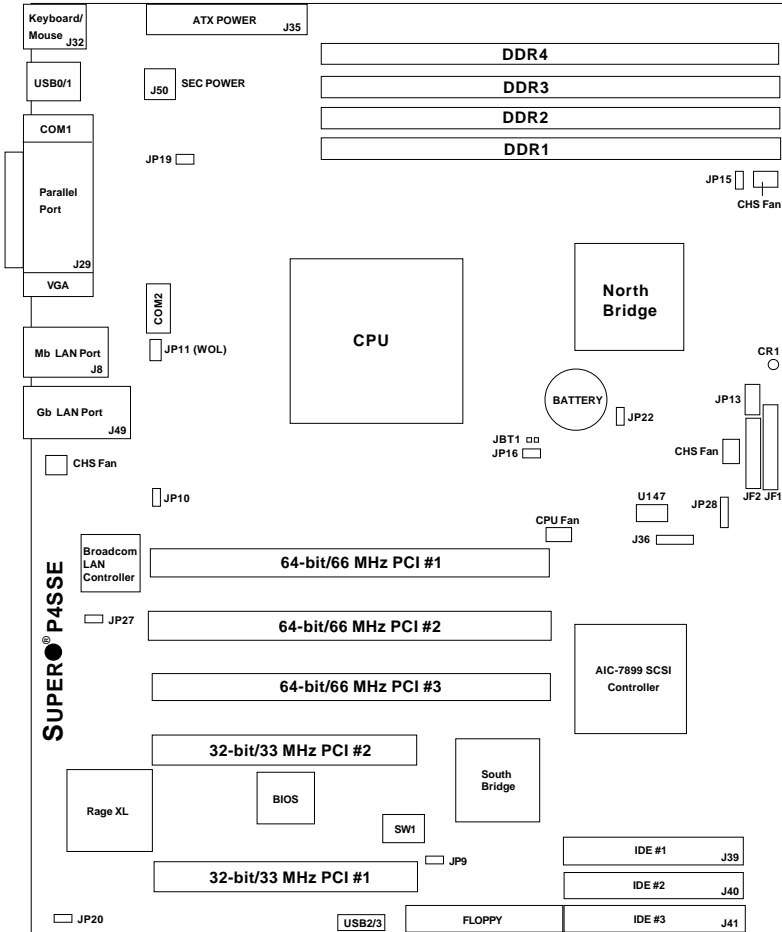

Note: DIP Switch 1 sets the processor speed (see Section 2-7).
Jumpers not noted are for test purposes only.

Also see Chapter 2 for the locations of the I/O ports and Front Control Panel (JF1/JF2) connectors and for details on jumper settings and pin definitions.

P4SSE Quick Reference

<u>Jumper</u>	<u>Description</u>	<u>Default Setting</u>
JBT1	CMOS Clear	See Chapter 2
JP9	VGA Enable/Disable	Pins 1-2 (Enabled)
JP10	Mb LAN Enable/Disable	Pins 1-2 (Enabled)
JP15	Fan Status Select	Open (OH Condition)
JP19	Watch Dog Enable/Disable	Open (Disabled)
JP20	Main Power Override	Off (Normal)
JP22	System Bus Speed Select	Pins 1-2 (Auto)
JP27	Gb LAN Enable/Disable	Pins 1-2 (Enabled)

<u>Switch</u>	<u>Description</u>
DIP Switch 1	Processor Speed

<u>Connector</u>	<u>Description</u>
COM1/COM2	COM1/COM2 Serial Ports
CPU/CHS/OH FAN	CPU/Chassis/Overheat Fan Headers
CPU	CPU Socket
DDR1-DDR4	Memory (SDRAM) Slots
JF1	Front Control Panel Headers
JF2	ChInt/NMI/HD LED/PWR LED Headers
JP11	Wake-on-LAN Header
JP16	Chassis Intrusion Header
JP28	External Speaker Header
J7	VGA Display (Monitor) Port
J8	Mb Ethernet Port
J28	Floppy Disk Drive Connector
J29	Parallel Printer Port
J32	PS/2 Keyboard/Mouse Ports
J35	Primary ATX Power Connector
J36	SMB Header
J39/J40/J41	IDE1/2/3 Hard Disk Drive Connector
J49	Gb Ethernet Port
J50	Secondary ATX Power Connector
USB0/1	Universal Serial Bus Ports
USB2/3	Universal Serial Bus Headers
U147	POST Messaging Voice BIOS (future option)

Motherboard Features

CPU

- Single Intel® Xeon™ 1.8 - 2.8 GHz processors with a 512K L2 cache at a front side (system) bus speed of 400 MHz.

Note: Please refer to the support section of our web site for a complete listing of supported processors (<http://www.supermicro.com/TechSupport.htm>).

Memory

- Four 184-pin DIMM sockets supporting up to 4 GB of registered ECC DDR-200 (PC1600) SDRAM

Note: DDR-266 (PC2100) memory is supported but only at 200 MHz (PC1600 speed).

Chipset

- ServerWorks Grand Champion SL

Expansion Slots

- Three 64-bit 33 MHz and two 32-bit 33 MHz PCI slots

BIOS

- 4 Mb AMI® Flash ROM
- APM 1.2, DMI 2.3, PCI 2.2, ACPI 1.0, Plug and Play (PnP), SMBIOS 2.3

PC Health Monitoring

- Onboard voltage monitors for CPU core, chipset voltage, +5V, +12V, -12V, +3.3V and +2.5V
- Fan status monitor with firmware/software on/off control
- Environmental temperature monitor and control
- Power-up mode control for recovery from AC power loss
- System overheat LED and control
- System resource alert

ACPI Features

- Microsoft OnNow
- Slow blinking LED for suspend state indicator
- Main switch override mechanism

Onboard I/O

- AIC-7902 for dual channel Ultra320 SCSI (P4SS8 only)
- Integrated ATI Rage XL Graphics Controller
- One Intel 82551 10/100 (Mb) fast Ethernet controller
- One Broadcom BCM5702 1Gb fast Ethernet controller
- 3 EIDE Ultra DMA/100 bus master interfaces
- 1 floppy port interface (up to 2.88 MB)
- 2 Fast UART 16550A compatible serial ports
- 1 EPP/ECP (Enhanced Parallel Port/Extended Capabilities Port)
- PS/2 mouse and PS/2 keyboard ports
- 4 USB (Universal Serial Bus) ports (USB 1.1)

Other

- Internal/external modem ring-on (S1 state support only)
- Recovery from AC power loss control
- Wake-on-LAN (WOL)
- Console redirection
- FUCI (Frontside USB Control Interface)

CD/Diskette Utilities

- BIOS flash upgrade utility
- Device Drivers

Dimensions

- P4SS8: ATX: 12" x 9.625" (305 x 244.5 mm)
- P4SSE: ATX: 12" x 9.625" (305 x 244.5 mm)

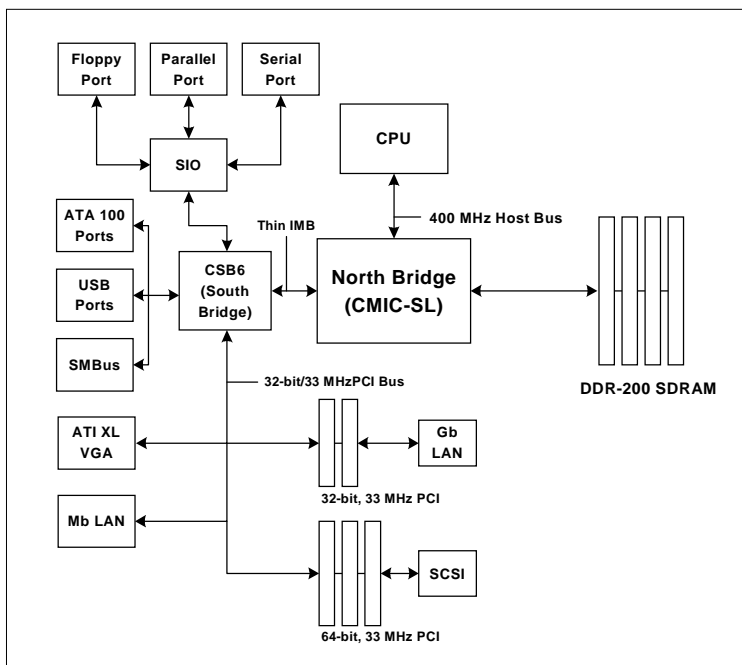

**Figure 1-5. ServerWorks Grand Champion SL Chipset:
System Block Diagram**

Note: This is a general block diagram. Please see the previous Motherboard Features Section for details on the features of each motherboard.

1-2 Chipset Overview

The Grand Champion SL™ is a fourth-generation product of ServerWorks "Champion" chipset technology. The GCSL chipset configuration used for the P4SS8/P4SSE is comprised of a North Bridge (CMIC-SL) and a South Bridge (CSB6).

The North Bridge interfaces directly to the processors via a 400 MHz Host bus and integrates the functions of the main memory subsystem and the IMB bus interface unit. The memory subsystem consists of a 4 DIMM configuration accessed over a 200 MHz memory bus at a peak bandwidth of 1.6 GB/sec.

The South Bridge provides various integrated functions, including the PCI bridge and support for UDMA100, security (passwords and system protection), Plug & Play, USBs, power management, interrupt controllers and the LPC Bus.

1-3 Special Features

ATI Graphics Controller

The P4SS8/P4SSE has an integrated ATI video controller based on the Rage XL graphics chip. The Rage XL fully supports sideband addressing and AGP texturing. This onboard graphics package can provide a bandwidth of up to 512 MB/sec over a 32-bit graphics memory bus.

BIOS Recovery

The BIOS Recovery function allows you to recover your BIOS image file if the BIOS flashing procedure fails (see Section 3-3).

Recovery from AC Power Loss

BIOS provides a setting for you to determine how the system will respond when AC power is lost and then restored to the system. You can choose for the system to remain powered off (in which case you must hit the power switch to turn it back on) or for it to automatically return to a power on state. See the Power Lost Control setting in the Advanced BIOS Setup section (Peripheral Device Configuration) to change this setting. The default setting is Always On.

1-4 PC Health Monitoring

This section describes the PC health monitoring features of the SUPER P4SS8/P4SSE. All have an onboard System Hardware Monitor chip that supports PC health monitoring.

Onboard Voltage Monitors for the CPU Core, Chipset Voltage, +5V, +12V, -12V, +3.3V and +2.5V

An onboard voltage monitor will scan these voltages continuously. Once a voltage becomes unstable, a warning is given or an error message is sent to the screen. Users can adjust the voltage thresholds to define the sensitivity of the voltage monitor.

Fan Status Monitor with Firmware/Software On/Off Control

The PC health monitor can check the RPM status (tachometer reading) of the cooling fans. The onboard 3-pin CPU and chassis fans are controlled by the power management functions. The thermal fan is controlled by the over-heat detection logic.

Environmental Temperature Control

The thermal control sensor monitors the CPU temperature in real time and will turn on the thermal control fan whenever the CPU temperature exceeds a user-defined threshold. The overheat circuitry runs independently from the CPU. It can continue to monitor for overheat conditions even when the CPU is in sleep mode. Once it detects that the CPU temperature is too high, it will automatically turn on the thermal control fan to prevent any overheat damage to the CPU. The onboard chassis thermal circuitry can monitor the overall system temperature and alert users when the chassis temperature is too high.

System Resource Alert

This feature is available when used with Intel's LANDesk Client Manager (retail only). LDCM is used to notify the user of certain system events. For example, if the system is running low on virtual memory and there is insufficient hard drive space for saving the data, you can be alerted of the potential problem.

Hardware BIOS Virus Protection

The system BIOS is protected by hardware that prevents viruses from infecting the BIOS area. The user can only change the BIOS content through the flash utility provided by Supermicro. This feature can prevent viruses from infecting the BIOS area and destroying valuable data.

Auto-Switching Voltage Regulator for the CPU Core

The auto-switching voltage regulator for the CPU core can support up to 20A current and auto-sense voltage IDs ranging from 1.4V to 3.5V. This will allow the regulator to run cooler and thus make the system more stable.

1-5 ACPI Features

ACPI stands for Advanced Configuration and Power Interface. The ACPI specification defines a flexible and abstract hardware interface that provides a standard way to integrate power management features throughout a PC system, including its hardware, operating system and application software. This enables the system to automatically turn on and off peripherals such as CD-ROMs, network cards, hard disk drives and printers. This also includes consumer devices connected to the PC such as VCRs, TVs, telephones and stereos.

In addition to enabling operating system-directed power management, ACPI provides a generic system event mechanism for Plug and Play and an operating system-independent interface for configuration control. ACPI leverages the Plug and Play BIOS data structures while providing a processor architecture-independent implementation that is compatible with Windows 2000.

Microsoft OnNow

The OnNow design initiative is a comprehensive, system-wide approach to system and device power control. OnNow is a term for a PC that is always on but appears to be off and responds immediately to user or other requests.

Slow Blinking LED for Suspend-State Indicator

When the CPU goes into a suspend state, the chassis power LED will start blinking to indicate that the CPU is in suspend mode. When the user presses any key, the CPU will wake-up and the LED will automatically stop blinking and remain on.

Main Switch Override Mechanism

When an ATX power supply is used, the power button can function as a system suspend button to make the system enter a SoftOff state. The monitor will be suspended and the hard drive will spin down. Depressing the power button again will cause the whole system to wake-up. During the SoftOff state, the ATX power supply provides power to keep the required circuitry in the system alive. In case the system malfunctions and you want to turn off the power, just depress and hold the power button for 4 seconds. This option can be set in the Power section of the BIOS Setup routine.

External Modem Ring-On

Wake-up events can be triggered by a device such as the external modem ringing when the system is in the SoftOff state (only S1 state is supported). Note that external modem ring-on can only be used with an ATX 2.01 (or above) compliant power supply.

Wake-On-LAN (WOL)

Wake-On-LAN is defined as the ability of a management application to remotely power up a computer that is powered off. Remote PC setup, updates and asset tracking can occur after hours and on weekends so that daily LAN traffic is kept to a minimum and users are not interrupted. The motherboards have a 3-pin header (WOL) to connect to the 3-pin header on a Network Interface Card (NIC) that has WOL capability. Wake-On-LAN must be enabled in BIOS. Note that the Broadcom 1 Gb LAN port only supports the S1 suspend state.

1-6 Power Supply

As with all computer products, a stable power source is necessary for proper and reliable operation. It is even more important for processors that have high CPU clock rates.

The SUPER P4SS8/P4SSE accommodates ATX power supplies. Although most power supplies generally meet the specifications required by the CPU, some are inadequate. You should use one that will supply at least 300W of power - an even higher wattage power supply is recommended for high-load configurations. Also your power supply must provide a +5V standby voltage that supplies at least 720 mA of current. In addition, 1.5A is needed for LAN1 and LAN2.

NOTE: Secondary 12v ATX power (at J50) is necessary to support Intel Xeon CPUs. Failure to provide this extra power will result in the CPUs becoming unstable after only a few minutes of operation. See Section 2-5 for details on connecting the power supply cables.

It is strongly recommended that you use a high quality power supply that meets ATX power supply Specification 2.02 or above. Additionally, in areas where noisy power transmission is present, you may choose to install a line filter to shield the computer from noise. It is recommended that you also install a power surge protector to help avoid problems caused by power surges.

1-7 Super I/O

The disk drive adapter functions of the Super I/O chip include a floppy disk drive controller that is compatible with industry standard 82077/765, a data separator, write pre-compensation circuitry, decode logic, data rate selection, a clock generator, drive interface control logic and interrupt and DMA logic. The wide range of functions integrated onto the Super I/O greatly reduces the number of components required for interfacing with floppy disk drives. The Super I/O supports 360 K, 720 K, 1.2 M, 1.44 M or 2.88 M disk drives and data transfer rates of 250 Kb/s, 500 Kb/s or 1 Mb/s. It also provides two high-speed, 16550 compatible serial communication ports (UARTs), one of which supports serial infrared communication. Each UART includes a 16-byte send/receive FIFO, a programmable baud rate generator, complete modem control capability and a processor interrupt system.

Each UART includes a 16-byte send/receive FIFO, a programmable baud rate generator, complete modem control capability and a processor interrupt system. Both UARTs provide legacy speed with baud rate of up to 115.2 Kbps as well as an advanced speed with baud rates of 250 K, 500 K, or 1 Mb/s, which support higher speed modems.

The Super I/O supports one PC-compatible printer port (SPP), Bi-directional Printer Port (BPP) , Enhanced Parallel Port (EPP) or Extended Capabilities Port (ECP).

The Super I/O provides functions that comply with ACPI (Advanced Configuration and Power Interface), which includes support of legacy and ACPI power management through an SMI or SCI function pin. It also features auto power management to reduce power consumption.

The IRQs, DMAs and I/O space resources of the Super I/O can flexibly adjust to meet ISA PnP requirements, which support ACPI and APM (Advanced Power Management).

Chapter 2 Installation

2-1 Static-Sensitive Devices

Electric-Static-Discharge (ESD) can damage electronic components. To prevent damage to your system board, it is important to handle it very carefully. The following measures are generally sufficient to protect your equipment from ESD.

Precautions

- Use a grounded wrist strap designed to prevent static discharge.
- Touch a grounded metal object before removing the board from the anti-static bag.
- Handle the board by its edges only; do not touch its components, peripheral chips, memory modules or gold contacts.
- When handling chips or modules, avoid touching their pins.
- Put the motherboard and peripherals back into their antistatic bags when not in use.
- For grounding purposes, make sure your computer chassis provides excellent conductivity between the power supply, the case, the mounting fasteners and the motherboard.

Unpacking

The motherboard is shipped in antistatic packaging to avoid static damage. When unpacking the board, make sure the person handling it is static protected.

2-2 PGA Processor and Heatsink Installation



When handling the processor package, avoid placing direct pressure on the label area of the fan. Also, do not place the motherboard on a conductive surface, which can damage the BIOS battery and prevent the system from booting up.

IMPORTANT: Always connect the power cord last and always remove it before adding, removing or changing any hardware components. Make sure that you install the processor into the CPU socket **before** you install the CPU heat sink.

1. Locate the following components, which are included in the shipping package.

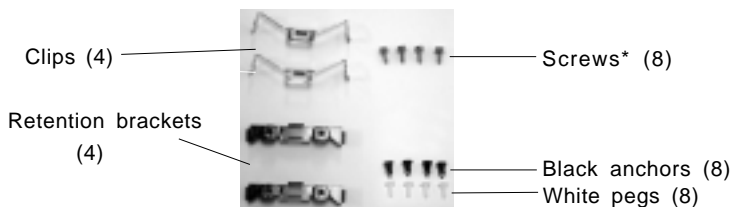

*These screws are for mounting the motherboard to the back panel of a chassis that has four mounting holes (as shown on right).



For chassis that do not have four mounting holes, use the anchor/peg assemblies:

2. Insert the white pegs into the black anchors. Do not force the white pegs all the way in - only about 1/3 of the way into the black anchors.

Anchor/peg assemblies



3. Place a retention bracket in the proper position and secure it by pressing pegs into two of the retention holes until you hear a *click*. The clicking sound indicates that the peg is locked and secured.

Two pegs in position



One retention bracket in position

4. Secure the other retention bracket into position by repeating Step 3.



5. Lift the lever on the CPU socket: lift the the lever completely or you will damage the CPU socket when power is applied.

Socket lever



6. Install the CPU in the socket. Make sure that pin 1 of the CPU is seated on pin 1 of the socket (both corners are marked with a triangle).

Pin 1

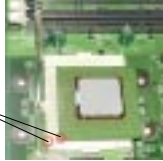

7. Press the lever down until you hear it *click* into the locked position.

Socket lever in locked position



8. Apply the proper amount of thermal compound to the CPU die and place the heatsink and fan on top of the CPU.

Heatsink

CPU



9. Secure the heatsink by locking the retention clips into their proper position.

Retention clip



10. Connect the three wires of the CPU fan to the respective CPU fan connector.

CPU fan wires

CPU fan connector

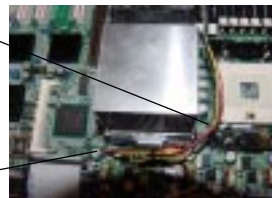
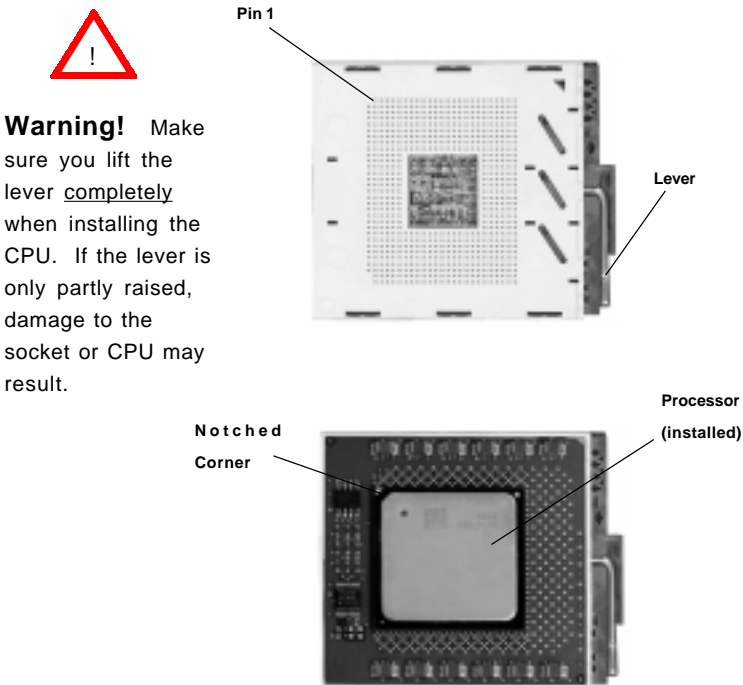

Figure 2-1. PGA603 Socket: Empty and with Processor Installed



Warning! Make sure you lift the lever completely when installing the CPU. If the lever is only partly raised, damage to the socket or CPU may result.

Mounting the Motherboard in the Chassis

All motherboards have standard mounting holes to fit different types of chassis. Make sure the location of all the mounting holes for both the motherboard and the chassis match. Although a chassis may have both plastic and metal mounting fasteners, metal ones are highly recommended because they ground the motherboard to the chassis. Make sure the metal standoffs click in or are screwed in tightly. Then use a screwdriver to secure the motherboard onto the motherboard tray.

2-3 Installing DIMMs

Note: Check the Supermicro web site for recommended memory modules:
http://www.supermicro.com/TECHSUPPORT/FAQs/Memory_vendors.htm

CAUTION

Exercise extreme care when installing or removing DIMM modules to prevent any possible damage.

DIMM Installation (See Figure 2-2)

1. Insert one to four memory modules. Memory is not interleaved, so you can add any number of DIMMs into the slots in any order.
2. Insert each DIMM module into its slot. Note the notch at the bottom of the module to prevent inserting the module incorrectly.
3. Gently press down on the DIMM module until it snaps into place in the slot. Repeat for more modules as desired.

Support

The P4SS8/P4SSE supports up to 4 GB of ECC registered DDR-200 (PC1600) SDRAM memory. PC2100 memory is supported but only runs at 200 MHz (PC1600 speed).

Figure 2-2. Installing and Removing DIMMs

To Install:

Insert the module vertically and press down until it snaps into place. Pay attention to the notch on the bottom of the module.

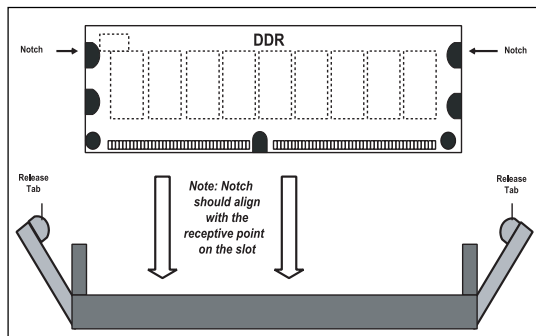

To Remove:

Use your thumbs to gently push near the edge of both ends of the module. This should release it from the slot.

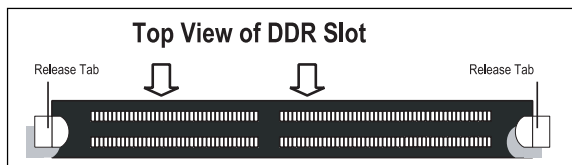

2-4 IOPorts/Control Panel Connectors

The IO ports are color coded in conformance with the PC 99 specification. See Figure 2-3 below for the colors and locations of the various IO ports.

Figure 2-3. IO Port Locations and Definitions

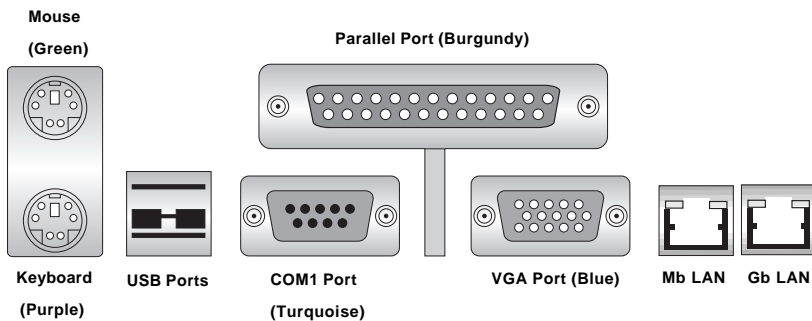

Note: COM2 is a header located on the motherboard behind the VGA port.

Front Control Panel

JF1 and JF2 contain header pins for various front control panel connectors. These connectors are designed for use with Supermicro server chassis. See Figure 2-4 for the pin locations of the various front control panel buttons and LED indicators. Refer to the following section for descriptions and pin definitions.

Figure 2-4. JF1/JF2 Header Pins

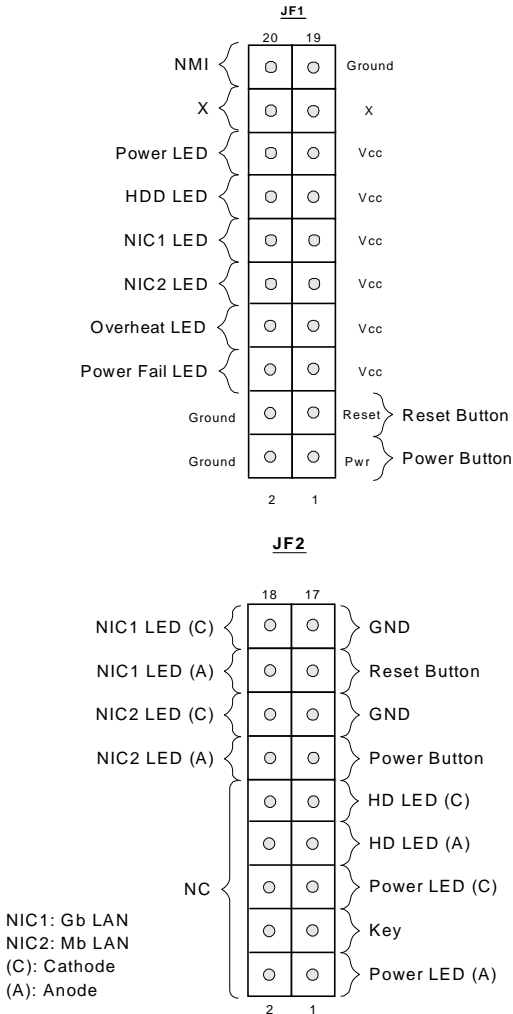

2-5 Connecting Cables

ATX Power Connection

The power supply connector (at J35) meets the SSI (Superset ATX) 24-pin specification, however it also supports a 20-pin power supply connector. Make sure that the orientation of the PS connector is correct. See the table on the right for pin definitions.

**24-pin ATX Power Supply Connector (J35)
Pin Definitions**

Pin Number	Definition	Pin Number	Definition
13	+3.3V	1	+3.3V
14	-12V	2	+3.3V
15	COM	3	COM
16	PS_ON#	4	+5V
17	COM	5	COM
18	COM	6	+5V
19	COM	7	COM
20	Res(NC)	8	PWR_OK
21	+5V	9	5VSB
22	+5V	10	+12V
23	+5V	11	+12V
24	COM	12	+3.3V

PWR_SEC Connection

In addition to the Primary ATX power connector (above), the Secondary 12v 4-pin PWR_SEC connector at J50 must also be connected to your power supply. See the table on the right for pin definitions.

**4-Pin +12v Power Supply
Connector (J50)**

Pins	Definition
1 & 2	Ground
3 & 4	+12v

Power LED

The Power LED connection is located on pins 15 and 16 of JF1. Refer to the table on the right for pin definitions.

**PWR_LED Pin Definitions
(JF1)**

Pin Number	Definition
15	+5V
16	Control

HDD LED

The HDD LED (for IDE Hard Disk Drives) connection is located on pins 13 and 14 of JF1. Attach the IDE hard drive LED cable to these pins to display disk activity. Refer to the table on the right for pin definitions.

**(IDE) HDD LED Pin
Definitions
(JF1)**

Pin Number	Definition
13	+5V
14	HD Active

L2 LED

The L2 (LAN2: Gb LAN) LED connection is located on pins 9 and 10 of JF1. Attach an LED cable to display network activity. Refer to the table on the right for pin definitions.

**L2 LED Pin
Definitions
(JF1)**

Pin Number	Definition
9	+5V
10	GND

L1 LED

The L1 (LAN1: Mb LAN) LED connection is located on pins 11 and 12 of JF1. Attach an LED cable to display network activity. Refer to the table on the right for pin definitions.

**L1 LED Pin
Definitions
(JF1)**

Pin Number	Definition
11	+5V
12	GND

Overheat LED (OH)

Connect an LED to the OH connection on pins 7 and 8 of JF1 to provide advanced warning of chassis overheating. Refer to the table on the right for pin definitions.

**Overheat (OH) LED
Pin Definitions
(JF1)**

Pin Number	Definition
7	+5V
8	GND

Power Fail LED

The Power Fail LED connection is located on pins 5 and 6 of JF1. Refer to the table on the right for pin definitions.

**Power Fail LED Pin
Definitions
(JF1)**

Pin Number	Definition
5	Control
6	GND

Reset

The Reset connection is located on pins 3 and 4 of JF1. Attach it to the hardware reset switch on the computer case. Refer to the table on the right for pin definitions.

**Reset Pin
Definitions
(JF1)**

Pin Number	Definition
3	Reset
4	Ground

PWR_ON

The PWR_ON connection is located on pins 1 and 2 of JF1. Momentarily contacting both pins will power on/off the system. This button can also be configured to function as a suspend button (see the Power Button Mode setting in BIOS). To turn off the power when set to suspend mode, depress the button for at least 4 seconds. Refer to the table on the right for pin definitions.

**PWR_ON Connector
Pin Definitions
(JF1)**

Pin Number	Definition
1	PW_ON
2	Ground

Universal Serial Bus (USB0/1)

Two Universal Serial Bus ports are located beside the keyboard/mouse ports. USB0 is the bottom connector and USB1 is the top connector. See the table on the right for pin definitions.

**Universal Serial Bus Pin Definitions
USB0 USB1**

USB0		USB1	
Pin Number	Definition	Pin Number	Definition
1	+5V	1	+5V
2	P0-	2	P0-
3	P0+	3	P0+
4	Ground	4	Ground
5	N/A	5	Key

Extra Universal Serial Bus Connection (USB2/3)

Two additional USB headers on the motherboard can provide convenient front side USB access. The odd numbered pins (toward the DIMM slots) are for USB2 and the even numbered pins (toward the SCSI chip) are for USB3. You will need a USB cable (not included) to use each of these connections. Refer to the tables on the right for pin definitions.

**USB2 Pin
Definitions**

Pin Number	Definition
1	Power
3	-
5	+
7	Ground
9	Key

**USB3 Pin
Definitions**

Pin Number	Definition
2	Power
4	-
6	+
8	Ground
10	NC

NC = No Connection

Serial Ports

The COM1 serial port is located under the parallel port (see Figure 2-3). See the table on the right for pin definitions. The COM2 connector is a header located behind the VGA port.

**Serial Port Pin Definitions
(COM1, COM2)**

Pin Number	Definition	Pin Number	Definition
1	DCD	6	CTS
2	DSR	7	DTR
3	Serial In	8	R1
4	RTS	9	Ground
5	Serial Out	10	NC

PS/2 Keyboard and Mouse Ports

The ATX PS/2 keyboard and the PS/2 mouse are located on J32. See the table on the right for pin definitions. (The mouse port is above the keyboard port. See Figure 2-3.)

**PS/2 Keyboard
and Mouse Port
Pin Definitions
(J32)**

Pin Number	Definition
1	Data
2	NC
3	Ground
4	VCC
5	Clock
6	NC

NC = No Connection

Fan Headers*

The P4SS8/P4SSE has one CPU, two Chassis and one Chassis/Overheat fan headers. See the table on the right for pin definitions.

**Fan Header Pin Definitions
(CPU/CHS/OH Fans)**

Pin Number	Definition
1	Ground (black)
2	+12V (red)
3	Tachometer

Caution: These fan headers are DC power.

LAN (Ethernet) Ports

Two Ethernet ports are located beside the VGA port on the IO backplane. These ports accept RJ45 type cables. See the next section for a description of the LEDs on the LAN ports.

Note: The P4SS8/P4SSE has one 100 Mb and one 1Gb LAN port. When viewed from the rear, the Mb port is on the left (see Figure 2-3).



HD LED Indicator

A HD LED connector is located on JF2 (see Figure 2-4). This LED indicates activity on any hard drive (IDE, SCSI or CD-ROM).

Chassis Intrusion

A Chassis Intrusion header is located at JF2 and another on JP16. Attach the appropriate connector here to inform you of a chassis intrusion condition.

Power LED

The Power LED connection on JF2 (see Figure 2-4) is used to inform you that power is being supplied to the motherboard.

Wake-On-LAN

The Wake-On-LAN header is designated JP11. See the table on the right for pin definitions. You must have a LAN card with a Wake-on-LAN connector and cable to use this feature.

**Wake-On-LAN Pin
Definitions (JP11)**

Pin Number	Definition
1	+5V Standby
2	Ground
3	Wake-up

SMB

An SMB (System Management Bus) header is located at J36. Connect the appropriate cable here to utilize SMB on your system.

**SMB Header
Pin Definitions (J36)**

Pin Number	Definition
1	Data
2	Ground
3	Clock
4	+5V Standby

External Speaker Header

Connect a cable from an external speaker to the JP28 header on the motherboard if you wish to use external speakers instead of the onboard speaker.

2-6 Onboard Indicators

LAN Port LEDs

Each of the Ethernet ports (located beside the VGA port) has a yellow and a green LED. See the tables to the right for the functions associated with these LEDs. On the Gb LAN port, the yellow LED indicates activity while the other LED may be green, orange or off to indicate the speed of the connection (as specified in the table at right).

100 Mb LAN LED Indicators

LED Color	Definition
Green	Connected
Yellow	Active

1 Gb LAN Right LED Indicator

LED Color	Definition
Off	No Connection
Green	100 MHz
Orange	1 GHz

1 Gb LAN Left LED Indicator

LED Color	Definition
Off	Not Active
Yellow	Active

CR1 LED

CR1 is an onboard LED that serves as a power indicator. It is located near JF1. See the table on the right for the meaning of each of the three colors displayed by CR1.

Onboard LED Power Indicator (CR1)

LED Color	Definition
Green	Power On
Yellow	Standby Mode
Red	CPU Error

2-7 DIP Switch Settings

DIP Switch 1: Processor Speed

The red "DIP" switch labeled SW1 has four individual switches, which are used to set the speed of the processor.

The table on the right shows you the switch settings for the various speeds your processor may be able to run at. (This table is also silkscreened on the motherboard.)

Note: Most Intel processors have a fixed Core/Bus ratio that overwrites the setting of DIP Switch 1.

Processor Speed Selection
(DIP Switch 1)

CPU	SW #1	SW #2	SW #3	SW #4
1.3 GHz	ON		ON	
1.4 GHz		ON	ON	
1.5 GHz	ON	ON	ON	
1.6 GHz				ON
1.7 GHz	ON			ON
1.8 GHz		ON		ON
1.9 GHz	ON	ON		ON
2.0 GHz			ON	ON
2.1 GHz	ON		ON	ON
2.2 GHz		ON	ON	ON
2.4 GHz	ON	ON	ON	ON

← Default

2-8 Jumper Settings

Explanation of Jumpers

To modify the operation of the motherboard, jumpers can be used to choose between optional settings. Jumpers create shorts between two pins to change the function of the connector. Pin 1 is identified with a square solder pad on the printed circuit board. See the motherboard layout pages for jumper locations.

Note: On two pin jumpers, "Closed" means the jumper is on and "Open" means the jumper is off the pins. "Off" means open with no jumper cap included for those pins.

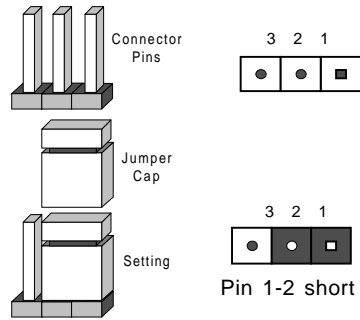

CMOS Clear

JBT1 is used to clear CMOS. Instead of pins, this jumper consists of contact pads to prevent accidental clearing of CMOS. To clear CMOS, use a metal object such as a small screwdriver to touch both pads at the same time to short the connection. Always remove the AC power cord from the system before clearing CMOS. JBT1 is located near the battery on the motherboard.

Note: For an ATX power supply, you must completely shut down the system, remove the AC power cord and then short JBT1 to clear CMOS. Do not use the PW ON connector to clear CMOS.

VGA Enable/Disable

JP9 allows you to enable or disable the VGA port. The default position is on pins 1 and 2 to enable VGA. See the table on the right for jumper settings.

**VGA Enable/Disable
Jumper Settings
(JP9)**

Jumper Position	Definition
1-2	Enabled
2-3	Disabled

Fan Status Select

JP15 allows you to change the status of the Overheat/Chassis fan to either activate only during an overheat condition (set in BIOS) or to remain active at all times. The default position is open. See the table on the right for jumper settings.

**Fan Status Select
Jumper Settings (JP15)**

Jumper Position	Definition
Open	Overheat
Closed	Always On

Watch Dog Enable/Disable

JP19 is used to enable or disable the Watch Dog function. This jumper is used together with the Watch Dog enable function in BIOS. Enable both the jumper and the BIOS setting to use the Watch Dog feature. See the table on the right for pin definitions.

**Watch Dog Enable/
Disable
Jumper Settings (JP19)**

Jumper Position	Definition
Open	Disabled
Closed	Enabled

Mb LAN Enable/Disable

Change the setting of jumper JP10 to enable or disable the Mb LAN port or NIC (Network Interface Card) on the motherboard. See the table on the right for jumper settings. The default setting is pins 1-2.

**Mb LAN
Enable/Disable
Jumper Settings
(JP10)**

Jumper Position	Definition
Pins 1-2	Enabled
Pins 2-3	Disabled

Gb LAN Enable/Disable

Change the setting of jumper JP27 to enable or disable the Gb LAN port or NIC (Network Interface Card) on the motherboard. See the table on the right for jumper settings. The default setting is pins 1-2.

**Gb LAN
Enable/Disable
Jumper Settings
(JP27)**

Jumper Position	Definition
Pins 1-2	Enabled
Pins 2-3	Disabled

SCSI Termination Enable/Disable (P4SS8 only)

Jumpers JPA1 and JPA2 allow you to enable or disable termination for the SCSI connectors. Jumper JPA1 controls SCSI channel A and JPA2 is for SCSI channel B. The normal (default) setting is open to enable (terminate) both SCSI channels. See the table on the right for jumper settings.

**SCSI Channel Termination
Enable/Disable
Jumper Settings
(JPA1, JPA2)**

Jumper Position	Definition
Open	Enabled
Closed	Disabled

SCSI Enable/Disable (P4SS8 only)

The SCSI Enable/Disable jumper at JA1 allows you to enable or disable the onboard SCSI. The normal (default) position is on pins 1-2 to enable SCSI. See the table on the right for jumper settings.

**SCSI Enable/Disable
Jumper Settings
(JA1)**

Jumper Position	Definition
Pins 1-2	Enabled
Pins 2-3	Disabled

2-9 Parallel Port, Floppy/Hard Disk Drive and SCSI Connections

Note the following when connecting the floppy and hard disk drive cables:

- The floppy disk drive cable has seven twisted wires.
- A red mark on a wire typically designates the location of pin 1.
- A single floppy disk drive ribbon cable has 34 wires and two connectors to provide for two floppy disk drives. The connector with twisted wires always connects to drive A, and the connector that does not have twisted wires always connects to drive B.

Parallel Port Connector

The parallel port is located on J29.

See the table below right for pin definitions.

**Parallel (Printer) Port Pin Definitions
(J29)**

Pin Number	Function	Pin Number	Function
1	Strobe-	2	Auto Feed-
3	Data Bit 0	4	Error-
5	Data Bit 1	6	Init-
7	Data Bit 2	8	SLCT IN-
9	Data Bit 3	10	GND
11	Data Bit 4	12	GND
13	Data Bit 5	14	GND
15	Data Bit 6	16	GND
17	Data Bit 7	18	GND
19	ACK	20	GND
21	BUSY	22	GND
23	PE	24	GND
25	SLCT	26	NC

Floppy Connector

The floppy connector is located on J28. See the table below for pin definitions.

Floppy Connector Pin Definitions
(JP28)

Pin Number	Function	Pin Number	Function
1	GND	2	FDHDIN
3	GND	4	Reserved
5	Key	6	FDEDIN
7	GND	8	Index-
9	GND	10	Motor Enable
11	GND	12	Drive Select B-
13	GND	14	Drive Select A-
15	GND	16	Motor Enable
17	GND	18	DIR-
19	GND	20	STEP-
21	GND	22	Write Data-
23	GND	24	Write Gate-
25	GND	26	Track 00-
27	GND	28	Write Protect-
29	GND	30	Read Data-
31	GND	32	Side 1 Select-
33	GND	34	Diskette

IDE Connectors

There are no jumpers to configure the onboard IDE#1, #2 and #3 connectors (J39, J40 and J41, respectively). See the table on the right for pin definitions.

Note: IDE#3 only supports a CD-ROM device.

IDE#1 and #2 support all devices and can also be used to support IDE RAID levels 0,1 and 10.

IDE Connector Pin Definitions
(J39, J40, J41)

Pin Number	Function	Pin Number	Function
1	Reset IDE	2	GND
3	Host Data 7	4	Host Data 8
5	Host Data 6	6	Host Data 9
7	Host Data 5	8	Host Data 10
9	Host Data 4	10	Host Data 11
11	Host Data 3	12	Host Data 12
13	Host Data 2	14	Host Data 13
15	Host Data 1	16	Host Data 14
17	Host Data 0	18	Host Data 15
19	GND	20	Key
21	DRQ3	22	GND
23	I/O Write-	24	GND
25	I/O Read-	26	GND
27	IOCHRDY	28	BALE
29	DACK3-	30	GND
31	IRQ14	32	IOCS16-
33	Addr 1	34	GND
35	Addr 0	36	Addr 2
37	Chip Select 0	38	Chip Select 1-
39	Activity	40	GND

Ultra320 SCSI Connector (P4SS6)

Refer to the table below for the pin definitions of the Ultra320 SCSI connectors located at JA2 and JA3.

68-pin Ultra320 SCSI Connectors
(JA2, JA3)

Connector Contact Number	Signal Names	Connector Contact Number	Signal Names
1	+DB(12)	35	-DB(12)
2	+DB(13)	36	-DB(13)
3	+DB(14)	37	-DB(14)
4	+DB(15)	38	-DB(15)
5	+DB(P1)	39	-DB(P1)
6	+DB(0)	40	-DB(0)
7	+DB(1)	41	-DB(1)
8	+DB(2)	42	-DB(2)
9	+DB(3)	43	-DB(3)
10	+DB(4)	44	-DB(4)
11	+DB(5)	45	-DB(5)
12	+DB(6)	46	-DB(6)
13	+DB(7)	47	-DB(7)
14	+DB(P)	48	-DB(P)
15	GROUND	49	GROUND
16	DIFSENS	50	GROUND
17	TERMPWR	51	TERMPWR
18	TERMPWR	52	TERMPWR
19	RESERVED	53	RESERVED
20	GROUND	54	GROUND
21	+ATN	55	-ATN
22	GROUND	56	GROUND
23	+BSY	57	-BSY
24	+ACK	58	-ACK
25	+RST	59	-RST
26	+MSG	60	-MSG
27	+SEL	61	-SEL
28	+C/D	62	-C/D
29	+REQ	63	-REQ
30	+I/O	64	-I/O
31	+DB(8)	65	-DB(8)
32	+DB(9)	66	-DB(9)
33	+DB(10)	67	-DB(10)
34	+DB(11)	68	-DB(11)

2-10 Installing Software Drivers

After all the hardware has been installed you must install the software drivers. The necessary drivers are all included on the Supermicro CD that came packaged with your motherboard. After inserting this CD into your CDROM drive, the display shown in Figure 2-5 should appear. (If this display does not appear, click on the My Computer icon and then on the icon representing your CDROM drive. Finally, double click on the S "Setup" icon.)

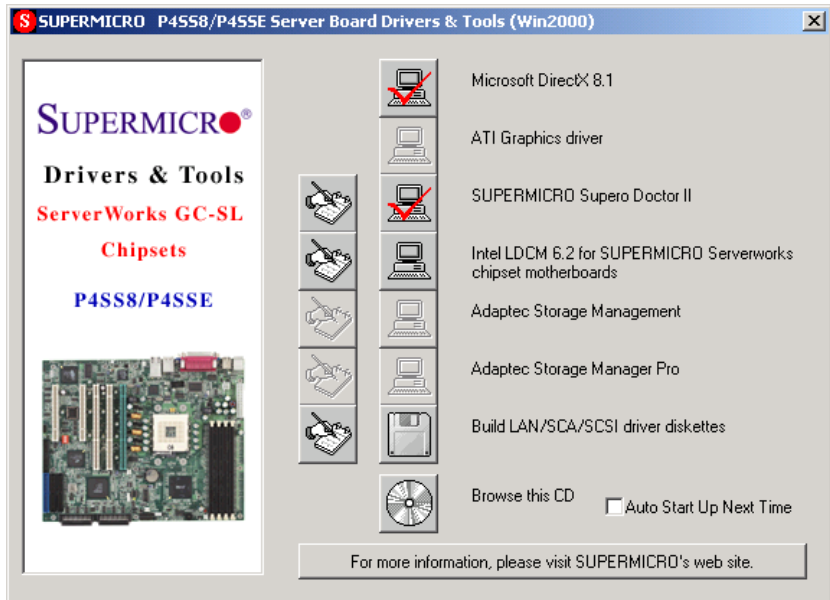

Figure 2-5. Driver/Tool Installation Display Screen

Click the icons showing a hand writing on paper to view the readme files for each item. The bottom icon with a CD on it allows you to view the entire contents of the CD.

Notes

Chapter 3

Troubleshooting

3-1 Troubleshooting Procedures

Use the following procedures to troubleshoot your system. If you have followed all of the procedures below and still need assistance, refer to the 'Technical Support Procedures' and/or 'Returning Merchandise for Service' section(s) in this chapter.

Note: Always disconnect the power cord before adding, changing or installing any hardware components.

Before Power On

1. Make sure no short circuits exist between the motherboard and chassis.
2. Disconnect all ribbon/wire cables from the motherboard, including those for the keyboard and mouse.
3. Remove all add-on cards.
4. Install one CPU (making sure it is fully seated) and connect the chassis speaker and the power LED to the motherboard. (Check all jumper settings as well.)

No Power

1. Make sure no short circuits exist between the motherboard and the chassis.
2. Verify that all jumpers are set to their default positions.
3. Check that the 115V/230V switch on the power supply is properly set.
4. Turn the power switch on and off to test the system.
5. The battery on your motherboard may be old. Check to verify that it still supplies ~3VDC. If it does not, replace it with a new one.

No Video

1. If the power is on but you have no video, remove all the add-on cards and cables.
2. Use the speaker to determine if any beep codes exist. Refer to Appendix A for details on beep codes.

NOTE

If you are a system integrator, VAR or OEM, a POST diagnostics card is recommended. For I/O port 80h codes, refer to App. B.

Memory Errors

1. Make sure the DIMM modules are properly and fully installed.
2. Determine if different speeds of DIMMs have been installed and verify that the BIOS setup is configured for the fastest speed of RAM used. It is recommended to use the same RAM speed for all DIMMs in the system.
3. Make sure you are using registered ECC, DDR-266/200 (PC2100/1600) SDRAM. EDO SDRAM and PC100/133 SDRAM are not supported.
4. Check for bad DIMM modules or slots by swapping a single module between two slots and noting the results.
5. Make sure all memory modules are fully seated in their slots.
6. Check the power supply voltage 115V/230V switch.

Losing the System's Setup Configuration

1. Ensure that you are using a high quality power supply. A poor quality power supply may cause the system to lose the CMOS setup information. Refer to Section 1-6 for details on recommended power supplies.
2. The battery on your motherboard may be old. Check to verify that it still supplies ~3VDC. If it does not, replace it with a new one.
3. If the above steps do not fix the Setup Configuration problem, contact your vendor for repairs.

3-2 Technical Support Procedures

Before contacting Technical Support, please take the following steps. Also, note that as a motherboard manufacturer, Super Micro does not sell directly to end-users, so it is best to first check with your distributor or reseller for troubleshooting services. They should know of any possible problem(s) with the specific system configuration that was sold to you.

1. Refer to the 'Troubleshooting Procedures' and 'Frequently Asked Question' (FAQ) sections in this chapter or see the FAQs on our web site before contacting Technical Support (<http://www.supermicro.com/>)

TECHSUPPORT/TechSupport.htm).

2. BIOS upgrades can be downloaded from our web site at <http://www.supermicro.com/TECHSUPPORT/BIOS/bios.htm>.

Note: Not all BIOS can be flashed depending on the modifications to the boot block code.

3. If you still cannot resolve the problem, include the following information when contacting Super Micro for technical support:

- Motherboard model and PCB revision number
- BIOS release date/version (this can be seen on the initial display when your system first boots up)
- System configuration

An example of a Technical Support form is on our web site at http://www.supermicro.com/TECHSUPPORT/Contact_Support.htm.

4. Distributors: For immediate assistance, please have your account number ready when placing a call to our technical support department. We can be reached by e-mail at support@supermicro.com, by fax at (408) 503-8019 or by phone at (408) 503-8000, option 2.

3-3 Frequently Asked Questions

Question: What are the various types of memory that the P4SS8/P4SSE motherboard can support?

Answer: The P4SS8/P4SSE has four 184-pin DIMM slots that support up to 4 GB of registered ECC DDR-200 (PC1600) SDRAM only (DDR-266 is supported but only runs at 200 MHz). Unbuffered SDRAM, non-ECC memory and PC100/133 SDRAM modules are not supported. Memory is not interleaved so you can install any number of DIMMs into the memory slots in any order.

Question: How do I update my BIOS?

Answer: It is recommended that you **do not** upgrade your BIOS if you are experiencing no problems with your system. Updated BIOS files are located on our web site (<http://www.supermicro.com>). Please check our BIOS warning message and the info on how to update your BIOS on our web site. Also, check the current BIOS revision and make sure it is newer than your BIOS before downloading. Select your motherboard model and download the BIOS file to your computer. Unzip the BIOS update file and you will

find the readme.txt (flash instructions), the flash.bat (BIOS flash utility) and the BIOS image (xxxxxx.rom) files. Copy these files onto a bootable floppy and reboot your system. It is not necessary to set BIOS boot block protection jumpers on the motherboard. At the DOS prompt, enter the command "flash." This will start the flash utility and give you an opportunity to save your current BIOS image. Flash the boot block and enter the name of the update BIOS image file.

Note: It is important to save your current BIOS and **rename it "amiboot.rom"** in case you need to recover from a failed BIOS update. Select flash boot block, then enter the update BIOS image. Select "Y" to start the BIOS flash procedure and do not disturb your system until the flash utility displays that the procedure is complete. After updating your BIOS, please clear the CMOS then load Optimal Values in the BIOS.

Question: After flashing the BIOS my system does not have video. How can I correct this?

Answer: If the system does not have video after flashing your new BIOS, it indicates that the flashing procedure failed. To remedy this, first clear CMOS per the instructions in this manual and retry the BIOS flashing procedure. If you still do not have video, please use the following **BIOS Recovery Procedure**. First, turn your system off and place the floppy disk with the saved BIOS image file (see above FAQ) in drive A. Press and hold <CTRL> and <Home> at the same time, then turn on the power with these keys pressed until your floppy drive starts reading. Your screen will remain blank until the BIOS program is done. If the system reboots correctly, then the recovery was successful. The BIOS Recovery Procedure will not update the boot block in your BIOS.

Question: What's on the CD that came with my motherboard?

Answer: The supplied compact disc has quite a few drivers and programs that will greatly enhance your system. We recommend that you review the CD and install the applications you need. Applications on the CD include chipset drivers for Windows and security and audio drivers.

Question: Why can't I turn off the power using the momentary power on/off switch?

Answer: The instant power off function is controlled in BIOS by the Power Button Mode setting. When the On/Off feature is enabled, the motherboard will have instant off capabilities as long as the BIOS has control of the system. When the Standby or Suspend feature is enabled or when the

BIOS is not in control such as during memory count (the first screen that appears when the system is turned on), the momentary on/off switch must be held for more than four seconds to shut down the system. This feature is required to implement the ACPI features on the motherboard.

3-4 Returning Merchandise for Service

A receipt or copy of your invoice marked with the date of purchase is required before any warranty service will be rendered. You can obtain service by calling your vendor for a Returned Merchandise Authorization (RMA) number. When returning to the manufacturer, the RMA number should be prominently displayed on the outside of the shipping carton, and mailed prepaid or hand-carried. Shipping and handling charges will be applied for all orders that must be mailed when service is complete.

This warranty only covers normal consumer use and does not cover damages incurred in shipping or from failure due to the alternation, misuse, abuse or improper maintenance of products.

During the warranty period, contact your distributor first for any product problems.

Notes

Chapter 4

BIOS

4-1 Introduction

This chapter describes the AMIBIOS for the P4SS8/P4SSE. The AMI ROM BIOS is stored in a Flash EEPROM and can be easily upgraded using a floppy disk-based program.

Note: Due to periodic changes to BIOS, some settings may have been added or deleted and might not yet be recorded in this manual. Refer to the Manual Download area of our web site for any changes to BIOS that are not reflected in this manual.

System BIOS

The BIOS is the Basic Input Output System used in all IBM® PC, XT™, AT®, and PS/2® compatible computers. The BIOS ROM stores the system parameters, such as amount of memory, type of disk drives and video displays, etc. BIOS ROM requires very little power. When the computer is turned off, a back-up battery provides power to the BIOS ROM, enabling it to retain the system parameters. Each time the computer is powered-on, the computer is then configured with the values stored in the BIOS ROM by the system BIOS, which gains control when the computer is powered on.

How To Change the Configuration Data

The configuration data that determines the system parameters may be changed by entering the BIOS Setup utility. This Setup utility can be accessed by pressing at the appropriate time during system boot.

Starting the Setup Utility

Normally, the only visible POST (Power On Self Test) routine is the memory test. As the memory is being tested, press the <Delete> key to enter the main menu of the BIOS Setup utility. From the main menu, you can access the other setup screens, such as the Chipset and Power menus. Section 4-3 gives detailed descriptions of each parameter setting in the Setup utility.

An AMIBIOS identification string is displayed at the left bottom corner of the screen, below the copyright message.

4-2 BIOS Features

- Supports Plug and Play V1.0A and DMI 2.3
- Supports Intel PCI (Peripheral Component Interconnect) (PME) local bus specification 2.2
- Supports Advanced Power Management (APM) specification v 1.1
- Supports ACPI
- Supports Flash ROM

AMIBIOS supports the LS120 drive made by Matsushita-Kotobuki Electronics Industries Ltd. The LS120:

- Can be used as a boot device
- Is accessible as the next available floppy drive

AMIBIOS supports PC Health Monitoring chips. When a failure occurs in a monitored activity, AMIBIOS can sound an alarm and display a message. The PC Health Monitoring chips monitor:

- CPU temperature
- Chassis intrusion detector
- Five positive voltage inputs
- Three fan speed monitor inputs

4-3 Running Setup

**Optimal default settings are in bold text unless otherwise noted.*

The BIOS setup options described in this section are selected by choosing the appropriate text from the Standard Setup screen. All displayed text is described in this section, although the screen display is often all you need to understand how to set the options (see on next page).

The Main BIOS Setup Menu

Press the <Delete> key during the POST (Power On Self Test) to enter the Main Menu of the BIOS Setup Utility. All Main Setup options are described in this section. The Main BIOS Setup screen is displayed below.

BIOS SETUP UTILITY		
Main	Advanced Chipset PCI/PnP	Power Boot Security Exit
AMIBIOS Version:	07.00xx	
BIOS Build Date:	05/22/02	
BIOS ID:	4DS80603	
Processor Type:	Intel®Xeon®	
Processor Speed:	2400 MHz	
System Memory:	2048 MB	
System Date	[10:10:00]	↔ Select Screen
System Time	[05/29/02]	↑↓ Select Item
		+ - Change Option
		F1 General Help
		F10 Save and Exit
		ESC Exit
V07.00 (C)Copyright 1985-2001, American Megatrends, Inc.		

Use the Up/Down arrow keys or the <Tab> key to move between the different settings in the above menu.

When the items "System Time", and "System Date" are highlighted, type in the correct time/date in the time field, and then press "Enter". The date must be entered in MM/DD/YY format. The time is entered in HH:MM:SS format. The time is in also 24-hour format. For example, 5:30 a.m. appears as 05:30:00 and 5:30 p.m. as 17:30:00.

Press the <ESC> key to exit the Main Menu and use the Left/Right arrow keys to enter the the other categories of BIOS settings. The next section is described in detail to illustrate how to navigate through the menus.

Note: Items displayed in gray are preset and cannot be selected. Items with a blue arrow are commands, not options (i.e. Discard Changes).

4-4 Advanced BIOS Setup

Choose Advanced BIOS Setup from the AMIBIOS Setup Utility main menu with the Left/Right arrow keys. You should see the following display. Select one of the items in the left frame of the screen, such as SuperIO Configuration, to go to the sub screen for that item. Advanced BIOS Setup options are displayed by highlighting the option using the arrow keys. All Advanced BIOS Setup options are described in this section.

BIOS SETUP UTILITY	
Main	Advanced
Chipset PCI/PnP Power Boot Security Exit Setup Warning Setting items on this screen to incorrect values may cause the system to malfunction! > SuperIO Configuration > IDE Configuration > Floppy Configuration > Boot Settings Configuration > Event Log Configuration > Peripheral Device Configuration > System Health Monitor > Remote Access Configuration	Configure SuperIO Chipset Winbond627F ← Select Screen ↑↓ Select Item Enter Go to Sub Screen F1 General Help F10 Save and Exit ESC Exit
V7.00 (C)Copyright 1985-2001, American Megatrends, Inc.	

Use the Up/Down arrow keys to select the "Super I/O Configuration line.

When the "Super IO Configuration" line is highlighted, hit "ENTER" to display its menu.

The following Super IO Configuration screen will appear. Here you can select your options for the your computer's I/O (Input/Output) devices.

Super IO Configuration

BIOS SETUP UTILITY	
<u>Advanced</u>	
<u>Configure Winbond627F Serial Port(s) and Parallel P</u>	
Serial Port1 Address	[3F8]
Serial Port1 IRQ	[4]
Serial Port2 Address	[2F8]
Serial Port2 IRQ	[3]
Serial Port2 Mode	[Normal]
Parallel Port Address	[378]
Parallel Port IRQ	[7]
Parallel Port Mode	[ECP]
ECP Mode DMA Channel	[3]
	↔ Select Screen ↑↓ Select Item +- Change Option F1 General Help F10 Save and Exit ESC Exit
V07.00 (C)Copyright 1985-2001, American Megatrends, Inc.	

The Super IO Configuration includes the following items:

Serial Port 1 Address

This option specifies the base I/O port address of serial port 1. The settings for this item include Disabled, **3F8** and 3E8 and 2E8. Select the desired setting and then press "Enter".

Serial Port 1 IRQ

This option specifies the Interrupt Request address of serial port 1. The settings for this item include Disabled, **4** and 3.

Serial Port 2 Address

This option specifies the base I/O port address of serial port 2. The settings for this item include Disabled, **2F8**, 3E8 and 2E8.

Serial Port 2 IRQ

This option specifies the Interrupt Request address of serial port 2. The settings for this item include Disabled, 4 and **3**.

Serial Port 2 Mode

Use this option to choose the Serial Port 2 Mode. The settings are **Normal**, Sharp-IR, SIR and consumer.

Parallel Port Address

This option specifies the I/O address used by the parallel port. The settings for this item include Disabled, **378**, 278 and 3BC. Select your setting and then press "Enter".

Parallel Port IRQ

This option allows the user to set the Parallel Port IRQ. The settings for this item include 5 and 7.

Parallel Port Mode

This option specifies the parallel port mode. The settings for this item include Normal, Bi-directional, EPP and **ECP**.

ECP Mode DMA Channel

This option allows the user to set the setting for the ECP Mode of the DMA Channel. The settings for this item include 0, 1 and 3.

IDE Configuration

Onboard PCI IDE Controller

This option allows the user to enable or disable the integrated IDE Controller. The settings include Disabled, Primary, Second and **Both**. Select "Disabled" to disable the Integrated IDE Controller. Select "Primary" to enable the Primary IDE ontroller only. Select "Secondary" to enable the Secondary IDE Controller only. Select "Both" to enable both Primary and Secondary IDE Controllers.

Primary IDE Master

When entering "Setup", BIOS automatically detects the presence of IDE devices. This displays the auto detection status of the IDE devices. You can also manually configure the IDE drives by providing the following information:

This option allows the user to configure the IDE devices. When the desired item is highlighted (selected), press "Enter" and the following screen will be displayed:

Type

This option sets the type of device that the AMIBIOS attempts to boot from after AMIBIOS POST is completed. The settings include Not installed, **Auto**, CDROM and ARMD. The "Auto" setting allows BIOS to automatically detect the presence of the IDE controller.

LBA/Large Mode

LBA (Logical Block Addressing) is a method of addressing data on a disk drive. In LBA mode, the maximum drive capacity is 137 GB. The settings are Disabled and **Auto**. Select "Disabled" to disable LBA mode. Select "Auto" to enable LBA mode if your device supports it and is not already formatted with the LBA mode.

Block (Multi-Sector Transfer) Mode

This option sets the block mode multi sector transfers option. The settings include Disabled and **Auto**. Disabled: This option prevents the BIOS from using Multi-Sector Transfer on the specified channel. The data to and from the device will occur one sector at a time. Auto: This option allows the BIOS to auto detect device support for Multi-Sector Transfers on the specified channel. If supported, this option allows the BIOS to auto detect the number of sectors per block for transfer from the hard disk drive to memory. The data transfer to and from the device will occur multiple sectors at a time (if the device supports it).

PIO Mode

IDE PIO (Programmable I/O) mode programs timing cycles between the IDE drive and the programmable IDE controller. As the PIO mode increases, the cycle time decreases. The settings are: **Auto**, 0, 1, 2, 3 and 4.

DMA Mode

This item allows the users to select the DMA mode. The settings are: **Auto**, SWDMA0, SWDMA1, SWDMA2, MWDMA0, MWDMA1, MWDMA2, UWDMA0, UWDMA1, UWDMA2, UWDMA3 and UWDMA4. Select Auto to auto detect the DMA Mode. Select SWDMA0 through SWDMA2 to set single word DMA0 through DMA2. Select MWDMA0 through MWDMA2 to set Multi-word DMA0 through DMA2. Select UDMA0 through UDMA4 to set Ultra DMA0 through Ultra DMA4.

S.M.A.R.T.

S.M.A.R.T stands for Self-Monitoring Analysis and Reporting Technology, a feature that can help predict impending drive failures. The settings are **Auto**, Disabled and Enabled. Select "Enabled" or "Disabled" to enable or disable the S.M.A.R.T. Select "Auto" to auto detect S.M.A.R.T.

32Bit Data Transfer

The settings are Auto, Disabled and **Enabled**. Select "Enabled" or "Disabled" to enable or disable the 32-bit Data Transfer function. Select "Auto" to auto detect the 32-bit Data Transfer function.

ARMD Emulation Type

This option is used to select the ARMD emulation type used when configuring an LS120, MO (Magneto-Optical), or Iomega Zip drive. The settings are **Auto**, Floppy and HardDisk. (ARMD stands for ATA(PI) Removable Media Disk).

Primary IDE Slave

When the system enters "Setup", BIOS automatically detects the presence of IDE devices. This option displays the auto detection status of IDE devices. The settings for "Primary IDE Slave" are the same as those for the "Primary IDE Master".

Secondary IDE Master

This displays the status of auto detection of IDE devices. The settings for "Secondary IDE Master" are the same as those for the "Primary IDE Master".

Secondary IDE Slave

This displays the status of auto detection of IDE devices. The settings for "Secondary IDE Slave" are the same as those for the "Primary IDE Master".

Hard Disk Write Protect

This item allows the user to prevent the hard disk from being overwritten. The options are Enabled or **Disabled**. Disabled allows the drive to be used normally; read, write and erase functions can all be performed. Enabled prevents the hard disk from being erased. This function is effective only when the device is accessed through BIOS.

ATA(PI) Detect Timeout (Seconds)

Set this option to stop the system search for ATAPI devices within the specified number of seconds. The options are 0, 5, 10, 15, 20, 25, 30 and **35** (seconds). Most ATA disk drives can be detected within 5 seconds.

ATA(PI) 80pin Cable Detection

This option allows you to select the mechanism used to detect the 80-pin ATA(PI) cable. The settings are Host, Device and **Host & Device**.

Floppy Configuration

Floppy A

Use this option to specify which of floppy drive you have installed in the A drive. The settings are Disabled, 360 KB 5 1/4", 1.2 MB 5 1/4", 720 KB 3 1/2", **1.44 MB 3 1/2"** and 2.88 MB 3 1/2".

Floppy B

Use this option to specify which of floppy drive you have installed in the B drive. The settings are **Disabled**, 360 KB 5 1/4", 1.2 MB 5 1/4", 720 KB 3 1/2", 1.44 MB 3 1/2" and 2.88 MB 3 1/2".

Floppy Drive Seek

Use this option to Enable or **Disable** the floppy seek routine on bootup.

Boot Settings Configuration

Quick Boot

This option allows the BIOS to skip certain tests that are normally performed on boot up. You can disable the option to speed up boot time. The settings are Disabled and **Enabled**.

Quiet Boot

If Disabled, this option will cause the normal POST messages to be displayed upon setup. When Enabled, the OEM logo is displayed instead of the POST messages. The settings are **Enabled** and Disabled.

Add-On ROM Display Mode

Set this option to display add-on ROM (read-only memory) messages. The settings for this option are **Force BIOS** and Keep Current. Force BIOS

allows the computer to force a third party BIOS to display during system boot. Keep Current has the system display AMIBIOS information on bootup.

BootUp Num Lock

This option is used to select the status of the Number Lock function on your keyboard on bootup. The settings are **On** and Off.

BootUp CPU Speed

This option is used set the CPU speed to either **High** or Low.

PS/2 Mouse Support

This option specifies whether a PS/2 Mouse will be supported. Settings are **Enabled** and Disabled.

Typematic Rate

Set this option to select the rate at which the computer repeats a key that is held down. Settings are **Fast** and Slow. Fast: This sets the rate the computer repeats a key to over 20 times per second. Under normal operations, this setting should not be changed. Slow: This sets the rate the computer repeats a key to under 8 times per second.

System Keyboard

This option is to let the system know if a keyboard is **Present** or Absent.

Primary Display

This option specifies the type of monitor display you have installed on the system. The settings are Absent, **VGA/EGA**, Color 40 x 25, Color 80 x 25 and monochrome.

Parity Check

Use this option to either Enable or **Disable** the use of memory parity checking.

Boot to OS/2

This option can be used to boot the system to an OS/2 operating system. The settings are **No** and Yes.

Wait for F1 if Error

This settings for this option are **Enabled** and Disabled. Disabled: This prevents the AMIBIOS to wait on an error for user intervention. This setting should be used if there is a known reason for a BIOS error to appear. An example would be a system administrator must remote boot the system. The computer system does not have a keyboard currently attached. If this setting is set, the system will continue to bootup in to the operating system. If 'F1' is enabled, the system will wait until the BIOS setup is entered. Enabled: This option allows the system BIOS to wait for any error. If an error is detected, pressing <F1> will enter Setup and the BIOS setting can be adjusted to fix the problem. This normally happens when upgrading the hardware and not setting the BIOS to recognize it.

Hit "Delete" Message Display

This option tells the system to display or not display the "Hit Delete to Enter Setup" message. The settings are **Enabled** and Disabled.

Cache

This option is for enabling or disabling the internal CPU L1 cache. Settings include Disabled, Write-Thru, **Write-Back** and Reserved. Disabled: This option prevents the system from using the internal CPU L1 cache. This setting should be used to slow the computer system down or to troubleshoot error messages. Write-Thru: This option allows the computer system to use the internal CPU L1 cache as Write-Through cache. Write-Through cache is slower than Write-Back cache. It performs write operations to the internal L1 CPU cache and system memory simultaneously. Write-Back: This option allows the computer system to use the internal CPU L1 cache as Write-Back cache. Write-Back cache is faster than Write-Through cache. Write-Back cache is a caching method in which modifications to data in the cache aren't copied to the cache source until absolutely necessary. Write-back caching is available on all CPUs supported by this BIOS. With these CPUs, write operations stored in the L1 cache aren't copied to main memory until absolutely necessary. This is the default setting.

System BIOS Cacheable

This option enables you to move the system BIOS to the memory cache to improve performance. Settings are **Enabled** and Disabled.

Event Log Configuration

Event Logging

This option **Enables** or Disables the logging of events. You can use this screen to select options for the Event Log Configuration Settings. You can access sub screens to view the event log and mark all events as read. Use the up and down arrow keys to select an item, and the plus (+) and minus (-) keys to change the option setting. The settings are described on the following pages. The screen is shown below.

ECC Event Logging

This option Enables or **Disables** the logging of ECC events. The events logged by AMIBIOS are post errors such as a bad BIOS, floppy errors, or hard drive errors.

Clear All Event Logs

This option can be used to tell the system to clear the event log on the next boot up. The settings are **No** and Yes.

View Event Log

Highlighting this and pressing <Enter> will allow you to view the unread events from the event log area.

Mark All Events As Read

Highlighting [OK] and pressing <Enter> will mark all events in the log area as having been read. The settings are OK and **Cancel**.

Peripheral Device Configuration

Power Lost Control

This option determines how the system will respond when power is reapplied after a power loss condition. Choose **Last State** to automatically start up the system when power is reapplied after an AC power loss. Always Off means you must push the main power button to restart the system after power is restored.

System Health Monitor

The BIOS continuously monitors the health of your system by measuring certain voltage levels and temperatures.

CPU1 Current Temperature

1st System Temperature

2nd System Temperature

These readings display the real-time temperatures of the CPU and two sensor points for chassis temperature. There are also several voltage level monitors as shown on the System Health Monitor screen.

Remote Access Configuration

Remote Access

This option allows the user to redirect the console (display) through the COM port when enabled. This is useful when two computers are hooked up to a single monitor. The function keys are disabled when this setting is enabled. The settings are "Serial ANSI" and "**Disabled.**"

4-5 Chipset Setup

Choose Chipset Setup from the AMIBIOS Setup Utility main menu. The screen is shown below. All Chipset Setup options are described following the screen.

BIOS SETUP UTILITY							
Main	Advanced	Chipset	PCIPnP	Power	Boot	Security	Exit
C000, 16k Shadow		[Cached]					Options for MCH
C400, 16k Shadow		[Cached]					
C800, 16k Shadow		[Cached]					
CC00, 16k Shadow		[Cached]					
D000, 16k Shadow		[Disabled]					
D400, 16k Shadow		[Disabled]					
D800, 16k Shadow		[Disabled]					
DC00, 16k Shadow		[Disabled]					
Memory Auto Precharge		[Disabled]					
Write Combining for P6-to-PCI		[Disabled]					
Memory Write Posting		[Enabled]					
Scrubbing Enabled		[Enabled]					
Memory Timing Control		[Auto]					
MPS 1.4 Support		[Enabled]					
Hyper-threading		[Enabled]					↔ Select Screen
Hot Spare Row		[Disabled]					↑↓ Select Item
Hide XIOAPIC PCI Functions		[Yes]					Enter Go to Sub Screen
Watchdog Timer		[Disabled]					F1 General Help
							F10 Save and Exit ESC
							Exit
V7.00 (C)Copyright 1985-2001, American Megatrends, Inc.							

C000, 16k Shadow

C400, 16k Shadow

C800, 16k Shadow

CC00, 16k Shadow

D000, 16k Shadow

D400, 16k Shadow

D800, 16k Shadow

DC00, 16k Shadow

These options specify how the 16 KB of video ROM at each of the above addresses is treated. When Disabled, the contents of the video ROM are not copied to RAM. When Enabled, the contents of 16 KB of video ROM beginning at the above address are copied (shadowed) from ROM to RAM

for faster application. The settings for this option are Disabled and Enabled. (The optimal settings are **Cached** for C000, C400, C800 and CC00 and **Disabled** for all the other addresses.

Memory Auto Precharge

The options for this setting are Enabled and **Disabled**. When enabled, an Auto Precharge for read/writes based on speculative algorithms is performed.

Write Combining for P6-to-PCI

This settings for this option are **Disabled** and Enabled. This enables or disables the combining (bursting) of accesses within the PCI memory regions.

Memory Writing Posting

The settings are **Enabled** and Disabled.

Scrubbing Enable

The settings are **Enabled** and Disabled. Scrubbing writes corrected ECC data back into memory.

Memory Timing Control

Determines how the memory timing is controlled. **Auto** lets BIOS program the memory timing from SPD data. **Manual** allows the user to select the appropriate memory timing.

Act to Deact

The settings are 5 Clks and **6 Clks**.

Act to Read/Write

The settings are **2 Clks** and 3 Clks.

RAS Precharge Time

This determines the duration of the time interval during which the Row Address Strobe signal to a DRAM is held low during normal Read and Write Cycles. The settings are **2 Clks** and 3 Clks.

RAS Cycle Time

This determines the cycle time of a Row Address Strobe. The settings are **6 Clks**, 7 Clks, 8 Clks and 9 Clks.

RAS Cycle Time after Refresh

This determines the amount of active time needed for a Row Address Strobe after a refresh. The settings are 8 Clks, 9 Clks and **10 Clks**.

MPS 1.4 Support

The settings for this option are **Enabled** and Disabled.

Hyper-threading

Enables hyper-threading if supported by the operating system. Hyper-threading is a method of creating an additional "virtual" processor by using parallelism to process multiple instructions simultaneously. The settings for this option are **Enabled** and Disabled.

Hot Spare Row

The settings for this option are Enabled and **Disabled**. When enabled, the amount of memory available for use is decreased.

Hide XIOAPIC PCI Functions

The settings for this option are **Yes** and No.

Watchdog Timer

This option is used to configure the Watchdog timer. Settings are **Disabled**, 2 minutes, 5 minutes, 10 minutes and 15 minutes.

Auto DQS Setting Support

The settings for this option are **Disabled** and Enabled.

DQS Selection

This setting is preset.

Spread Spectrum

Spread Spectrum is a technique used to stabilize a system that is being affected by electromagnetic interference. The settings for this option are **Disabled** and Enabled.

Memory Enhance Mapping

The settings for this option are **Enabled** and Disabled.

Buffer Compensation

The settings for this option are **Enabled** and Disabled.

4-6 PCI PnP Setup

Choose PCI/PnP Setup from the AMIBIOS Setup main menu. All PCI/PnP options are described in this section. The PCI/PnP Setup screen is shown below.

BIOS SETUP UTILITY							
Main	Advanced	Chipset	PCI/PnP	Power	Boot	Security	Exit
Plug & Play O/S			[No]				
Reset Config Data			[No]				
PCI Latency Timer			[64]				
Allocate IRQ to VGA			[Yes]				
Palette Snooping			[Disabled]				
PCI IDE BusMaster			[Disabled]				
USB Function			[Enabled]				
Legacy USB Support			[Auto]				
ARMD Emulation Type			[Hard Disk]				
						No: lets the BIOS configure all the devices in the system. Yes: lets the operating system configure Plug and Play (PnP) devices not required for boot if your system has a Plug and Play operating system.	
						↔ Select Screen ↑↓ Select Item +- Change Option F1 General Help F10 Save and Exit ESC Exit	
V07.00 (C)Copyright 1985-2001, American Megatrends, Inc.							

Plug & Play OS

This option specifies how Plug and Play devices will be configured. The settings are **Yes** and **No**. **No** lets BIOS configure all devices in the system. **Yes** lets the operating system (if supported) configure PnP devices not required for bootup.

Reset Configuration Data

Choosing the **Yes** setting will cause the PnP configuration data in the BIOS to be cleared on the next boot up. Choosing the **No** setting does not force PnP data to be cleared on the next boot.

PCI Latency Timer

This option specifies the latency timing of the PCI clocks for all PCI devices. Settings include 32, **64**, 96, 128, 160, 192, 224 and 248 PCI clocks.

Allocate IRQ to PCI VGA

This option lets you allocate an interrupt request (IRQ) to the PCI VGA adapter card (if used). The settings are **Yes** and **No**.

Palette Snooping

When enabled, this option informs PCI devices that an ISA graphics device is installed. The settings are **Disabled** and **Enabled**. This does not necessarily indicate a physical ISA adapter card. The graphics chipset can be mounted on a PCI card. Always check with your adapter card manuals first, before modifying the default settings in the BIOS.

PCI IDE BusMaster

The settings for this option are **Disabled** and **Enabled**. Enable to specify that the IDE controller on the PCI bus has bus mastering capabilities.

USB Function

The settings for this option are **Disabled** and **Enabled**. **Disabled** prevents the use of the USB ports and **Enabled** allows the use of the USB ports.

Legacy USB Support

This option allows you to enable support for Legacy USB. The settings are **Auto**, **Enabled** and **Disabled**.

ARMD Emulation Type

This settings for this option are **Hard Disk**, **Auto** and **Floppy**.

4-7 Power Setup

Choose Power Setup from the AMIBIOS Setup main menu. All Power Setup options are described in this section. The Power Setup screen is shown below.

BIOS SETUP UTILITY	
Main	Advanced
Chipset	PCIPnP
Power	Boot
Security	Exit
ACPI Aware O/S	[Yes]
Power Management	[Enabled]
Power Button Mode	[On/Off]
Suspend Timeout (Minutes)	[Off]
	↔ Select Screen ↑↓ Select Item +- Change Option F1 General Help F10 Save and Exit ESC Exit
V07.00 (C)Copyright 1985-2001, American Megatrends, Inc.	

ACPI Aware O/S

This option allows the system to utilize Intel's ACPI (Advanced Configuration and Power Interface) specification. Settings are **No** and **Yes**. DOS®, Windows 3.x®, and Windows NT® are examples of non-ACPI aware operating systems. Windows 95®, Windows 98®, Windows ME® and Windows 2000® are examples of ACPI aware operating systems.

Power Management

When enabled, this option displays the following four options relating to power management. The settings are **Disabled** and **Enabled**.

Power Button Mode

This option allows you to change the function of the chassis power button. The settings are **On/Off** and **Suspend**. When set to **Suspend**, depressing the power button when the system is up will cause it to enter a suspend state.

Suspend Timeout

This option specifies the length of hard disk inactivity time that should expire before entering the power conserving state. The settings are **Off**, 1, 2, 3, 4, 5, 6, 7, 8, 9 and 10 (minutes).

4-8 Boot Setup

Choose Boot Setup from the AMIBIOS Setup main menu. All Boot Setup options are described in this section. The Boot Setup screen is shown below.

BIOS SETUP UTILITY							
Main	Advanced	Chipset	PCIPnP	Power	Boot	Security	Exit
> <u>Boot Device Priority</u> > Hard Disk Drives > Removable Devices > ATAPI CDROM Drives						↔ Select Screen ↑↓ Select Item Enter Go to Sub Screen F1 General Help F10 Save and Exit ESC Exit	
V02.03 (C)Copyright 1985-2000, American Megatrends, Inc.							

Boot Device Priority

1st Boot Device

This option is used to specify the order of the boot sequence that will be followed from the available system devices. The settings for the 1st Boot Device are **Removable Device**, ATAPI CDROM, Hard Drive and Intel UNDI PXE-2.0 (build 082).

2nd Boot Device

The settings for the 2nd Boot Device are Removable Device, **ATAPI CDROM**, Hard Drive and Intel UNDI PXE-2.0 (build 082).

3rd Boot Device

The settings for the 3rd Boot Device are Removable Device, ATAPI CDROM, **Hard Drive** and Intel UNDI PXE-2.0 (build 082).

4th Boot Device

The settings for the 4th Boot Device are Removable Device, ATAPI CDROM, Hard Drive and **Intel UNDI PXE-2.0 (build 082)**.

Hard Disk Drives

Use this screen to view the boot sequency of hard drives that have been auto-detected or entered manually on your system.

Removable Devices

Use this screen to view the boot sequency of the removeable devices that have been auto-detected or entered manually on your system.

ATAPI CDROM Drives

Use this screen to view the boot sequency ofthe ATAPI CDROM drives that have been auto-detected or entered manually on your system.

4-9 Security Setup

Choose Security Setup from the AMIBIOS Setup main menu. All Security Setup options are described in this section. The Security Setup screen is shown below.

BIOS SETUP UTILITY							
Main	Advanced	Chipset	PCI/PnP	Power	Boot	Security	Exit
Supervisor Password :						Not Installed	
User Password :						Not Installed	
> Change Supervisor Password							
> Change User Password							
> Clear User Password							
Boot Sector Virus Protection						[Disabled]	
						Install or Change the password.	
						↔ Select Screen	
						↑↓ Select Item	
						Enter Go to Sub Screen	
						F1 General Help	
						F10 Save and Exit	
						ESC Exit	
V02.03 (C)Copyright 1985-2000, American Megatrends, Inc.							

Supervisor Password

User Password

AMIBIOS provides both Supervisor and User password functions. If you use both passwords, the Supervisor password must be set first. The system can be configured so that all users must enter a password every time the system boots or when AMIBIOS Setup is executed, using either or both the Supervisor password or User password. The Supervisor and User passwords activate two different levels of password security. If you select password support, you are prompted for a 1 – 6 character password. Type the password on the keyboard. The password does not appear on the screen when typed. Make sure you write it down. If you forget it, you must clear CMOS and reconfigure. **Remember your Password!** Keep a record of the new password when the password is changed. If you forget the password, you must erase the system configuration information in CMOS.

Change Supervisor Password

This option allows you to change a supervisor password that was entered previously.

Change User Password

This option allows you to change a user password that was entered previously.

Clear User Password

Use this option to clear the user password so that it is not required to be entered when the system boots up.

Boot Sector Virus Protection

This option allows you to enable or disable a virus detection program to protect the boot sector of your hard disk drive. The settings for this option **Disabled** and Enabled. If Enabled, AMIBIOS will display a warning when any program (or virus) issues a Disk Format command or attempts to write to the boot sector of the hard disk drive.

4-10 Exit Setup

Choose Exit Setup from the AMIBIOS Setup main menu. All Exit Setup options are described in this section. The Exit Setup screen is shown below.

BIOS SETUP UTILITY							
Main	Advanced	Chipset	PCIPnP	Power	Boot	Security	Exit
> <u>Exit Saving Changes</u> > Exit Discarding Changes > Load Optimal Defaults > Load Fail-Safe Defaults > Discard Changes							Exit system setup with saving the changes.
							↔ Select Screen ↑↓ Select Item Enter Go to Sub Screen F1 General Help F10 Save and Exit ESC Exit
V02.03 (C)Copyright 1985-2000, American Megatrends, Inc.							

Exit Saving Changes

Highlighting this setting and then pressing <Enter> will save any changes you made in the BIOS Setup program and then exit. Your system should then continue with the boot up procedure.

Exit Discarding Changes

Highlighting this setting and then pressing <Enter> will ignore any changes you made in the BIOS Setup program and then exit. Your system should then continue with the boot up procedure.

Load Optimal Defaults

Highlighting this setting and then pressing <Enter> provides the optimum performance settings for all devices and system features.

Load Failsafe Defaults

Highlighting this setting and then pressing <Enter> provides the safest set of parameters for the system. Use them if the system is behaving erratically.

Discard Changes

Highlighting this setting and then pressing <Enter> will ignore any changes you made in the BIOS Setup program but will not exit the BIOS Setup program.

Appendix A

BIOS Error Beep Codes

During the POST (Power-On Self-Test) routines, which are performed each time the system is powered on, errors may occur.

Non-fatal errors are those which, in most cases, allow the system to continue the boot-up process. The error messages normally appear on the screen.

Fatal errors are those which will not allow the system to continue the boot-up procedure. If a fatal error occurs, you should consult with your system manufacturer for possible repairs.

These fatal errors are usually communicated through a series of audible beeps. The numbers on the fatal error list, on the following page, correspond to the number of beeps for the corresponding error. All errors listed, with the exception of Beep Code 8, are fatal errors.

A-1 BIOS Error Beep Codes

Beeps	Error Message	Description
1 beep	Refresh	Circuits have been reset. (Ready to power up.)
1 long, 5 short beeps	Memory error	No memory detected in system
1 long, 8 short beeps	Display memory read/write error	Video adapter missing or with faulty memory

Notes

Appendix B

BIOS POST Codes

When BIOS performs the Power On Self Test, it writes checkpoint codes to I/O port 0080h. If the computer cannot complete the boot process, diagnostic equipment can be attached to the computer to read I/O port 0080h.

B-1 Uncompressed Initialization Codes

The uncompressed initialization checkpoint codes are listed in order of execution:

Checkpoint	Code Description
D0h	The NMI is disabled. Power on delay is starting. Next, the initialization code checksum will be verified.
D1h	Initializing the DMA controller, performing the keyboard controller BAT test, starting memory refresh, and entering 4 GB flat mode next.
D3h	Starting memory sizing next.
D4h	Returning to real mode. Executing any OEM patches and setting the Stack next.
D5h	Passing control to the uncompressed code in shadow RAM at E000:0000h. The initialization code is copied to segment 0 and control will be transferred to segment 0.
D6h	Control is in segment 0. Next, checking if <Ctrl> <Home> was pressed and verifying the system BIOS checksum. If either <Ctrl> <Home> was pressed or the system BIOS checksum is bad, next will go to checkpoint code E0h. Otherwise, going to checkpoint code D7h.

B-2 Bootblock Recovery Codes

The bootblock recovery checkpoint codes are listed in order of execution:

Checkpoint	Code	Description
E0h		The onboard floppy controller if available is initialized. Next, beginning the base 512 KB memory test.
E1h		Initializing the interrupt vector table next.
E2h		Initializing the DMA and Interrupt controllers next.
E6h		Enabling the floppy drive controller and Timer IRQs. Enabling internal cache memory.
Edh		Initializing the floppy drive.
Eeh		Looking for a floppy diskette in drive A:. Reading the first sector of the diskette.
Efh		A read error occurred while reading the floppy drive in drive A:.
F0h		Next, searching for the AMIBOOT.ROM file in the root directory.
F1h		The AMIBOOT.ROM file is not in the root directory.
F2h		Next, reading and analyzing the floppy diskette FAT to find the clusters occupied by the AMIBOOT.ROM file.
F3h		Next, reading the AMIBOOT.ROM file, cluster by cluster.
F4h		The AMIBOOT.ROM file is not the correct size.
F5h		Next, disabling internal cache memory.
FBh		Next, detecting the type of flash ROM.
FCh		Next, erasing the flash ROM.
FDh		Next, programming the flash ROM.
FFh		Flash ROM programming was successful. Next, restarting the system BIOS.

B-3 Uncompressed Initialization Codes

The following runtime checkpoint codes are listed in order of execution.

These codes are uncompressed in F0000h shadow RAM.

Checkpoint	Code	Description
03h		The NMI is disabled. Next, checking for a soft reset or a power on condition.
05h		The BIOS stack has been built. Next, disabling cache memory.
06h		Uncompressing the POST code next.
07h		Next, initializing the CPU and the CPU data area.
08h		The CMOS checksum calculation is done next.
0Ah		The CMOS checksum calculation is done. Initializing the CMOS status register for date and time next.
0Bh		The CMOS status register is initialized. Next, performing any required

	initialization before the keyboard BAT command is issued.
0Ch	The keyboard controller input buffer is free. Next, issuing the BAT command to the keyboard controller.
0Eh	The keyboard controller BAT command result has been verified. Next, performing any necessary initialization after the keyboard controller BAT command test.
0Fh	The initialization after the keyboard controller BAT command test is done. The keyboard command byte is written next.
10h	The keyboard controller command byte is written. Next, issuing the Pin 23 and 24 blocking and unblocking command.
11h	Next, checking if <End or <Ins> keys were pressed during power on. Initializing CMOS RAM if the <i>Initialize CMOS RAM in every boot</i> AMIBIOS POST option was set in AMIBCP or the <End> key was pressed.
12h	Next, disabling DMA controllers 1 and 2 and interrupt controllers 1 and 2.
13h	The video display has been disabled. Port B has been initialized. Next, initializing the chipset.
14h	The 8254 timer test will begin next.
19h	The 8254 timer test is over. Starting the memory refresh test next.
1Ah	The memory refresh line is toggling. Checking the 15 second on/off time next.
2Bh	Passing control to the video ROM to perform any required configuration before the video ROM test.
2Ch	All necessary processing before passing control to the video ROM is done. Looking for the video ROM next and passing control to it.
2Dh	The video ROM has returned control to BIOS POST. Performing any required processing after the video ROM had control.
23h	Reading the 8042 input port and disabling the MEGAKEY Green PC feature next. Making the BIOS code segment writable and performing any necessary configuration before initializing the interrupt vectors.
24h	The configuration required before interrupt vector initialization has completed. Interrupt vector initialization is about to begin.

Checkpoint	Code	Description
25h		Interrupt vector initialization is done. Clearing the password if the POST DIAG switch is on.
27h		Any initialization before setting video mode will be done next.
28h		Initialization before setting the video mode is complete. Configuring the monochrome mode and color mode settings next.
2Ah		Bus initialization system, static, output devices will be done next, if present. See the last page for additional information.
2Eh		Completed post-video ROM test processing. If the EGA/VGA controller is not found, performing the display memory read/write test next.
2Fh		The EGA/VGA controller was not found. The display memory read/write test is about to begin.
30h		The display memory read/write test passed. Look for retrace checking next.
31h		The display memory read/write test or retrace checking failed. Performing the alternate display memory read/write test next.
32h		The alternate display memory read/write test passed. Looking for alternate display retrace checking next.
34h		Video display checking is over. Setting the display mode next.
37h		The display mode is set. Displaying the power on message next.
38h		Initializing the bus input, IPL, general devices next, if present. See the last page of this chapter for additional information.
39h		Displaying bus initialization error messages. See the last page of this chapter for additional information.
3Ah		The new cursor position has been read and saved. Displaying the <i>Hit </i> message next.
3Bh		The <i>Hit </i> message is displayed. The protected mode memory test is about to start.
40h		Preparing the descriptor tables next.
42h		The descriptor tables are prepared. Entering protected mode for the memory test next.
43h		Entered protected mode. Enabling interrupts for diagnostics mode next.
44h		Interrupts enabled if the diagnostics switch is on. Initializing data to check memory wraparound at 0:0 next.
45h		Data initialized. Checking for memory wraparound at 0:0 and finding the total system memory size next.
46h		The memory wraparound test is done. Memory size calculation has been done. Writing patterns to test memory next.
47h		The memory pattern has been written to extended memory. Writing patterns to the base 640 KB memory next.

Checkpoint	Code	Description
48h		Patterns written in base memory. Determining the amount of memory below 1 MB next.
49h		The amount of memory below 1 MB has been found and verified. Determining the amount of memory above 1 MB memory next.
4Bh		The amount of memory above 1 MB has been found and verified. Checking for a soft reset and clearing the memory below 1 MB for the soft reset next. If this is a power on situation, going to checkpoint 4Eh next.
4Ch		The memory below 1 MB has been cleared via a soft reset. Clearing the memory above 1 MB next.
4Dh		The memory above 1 MB has been cleared via a soft reset. Saving the memory size next. Going to checkpoint 52h next.
4Eh		The memory test started, but not as the result of a soft reset. Displaying the first 64 KB memory size next.
4Fh		The memory size display has started. The display is updated during the memory test. Performing the sequential and random memory test next.
50h		The memory below 1 MB has been tested and initialized. Adjusting the displayed memory size for relocation and shadowing next.
51h		The memory size display was adjusted for relocation and shadowing. Testing the memory above 1 MB next.
52h		The memory above 1 MB has been tested and initialized. Saving the memory size information next.
53h		The memory size information and the CPU registers are saved. Entering real mode next.
54h		Shutdown was successful. The CPU is in real mode. Disabling the Gate A20 line, parity, and the NMI next.
57h		The A20 address line, parity, and the NMI are disabled. Adjusting the memory size depending on relocation and shadowing next.
58h		The memory size was adjusted for relocation and shadowing. Clearing the <i>Hit </i> message next.
59h		The <i>Hit </i> message is cleared. The <i><WAIT...></i> message is displayed. Starting the DMA and interrupt controller test next.

Checkpoint	Code	Description
60h		The DMA page register test passed. Performing the DMA Controller 1 base register test next.
62h		The DMA controller 1 base register test passed. Performing the DMA controller 2 base register test next.
65h		The DMA controller 2 base register test passed. Programming DMA controllers 1 and 2 next.
66h		Completed programming DMA controllers 1 and 2. Initializing the 8259 interrupt controller next.
67h		Completed 8259 interrupt controller initialization.
7Fh		Extended NMI source enabling is in progress.
80h		The keyboard test has started. Clearing the output buffer and checking for stuck keys. Issuing the keyboard reset command next.
81h		A keyboard reset error or stuck key was found. Issuing the keyboard controller interface test command next.
82h		The keyboard controller interface test completed. Writing the command byte and initializing the circular buffer next.
83h		The command byte was written and global data initialization has completed. Checking for a locked key next.
84h		Locked key checking is over. Checking for a memory size mismatch with CMOS RAM data next.
85h		The memory size check is done. Displaying a soft error and checking for a password or bypassing WINBIOS Setup next.
86h		The password was checked. Performing any required programming before WINBIOS Setup next.
87h		The programming before WINBIOS Setup has completed. Uncompressing the WINBIOS Setup code and executing the AMIBIOS Setup or WINBIOS Setup utility next.
88h		Returned from WINBIOS Setup and cleared the screen. Performing any necessary programming after WINBIOS Setup next.
89h		The programming after WINBIOS Setup has completed. Displaying the power on screen message next.
8Bh		The first screen message has been displayed. The <WAIT...> message is displayed. Performing the PS/2 mouse check and extended BIOS data area allocation check next.
8Ch		Programming the WINBIOS Setup options next.
8Dh		The WINBIOS Setup options are programmed. Resetting the hard disk controller next.
8Fh		The hard disk controller has been reset. Configuring the floppy drive controller next.
91h		The floppy drive controller has been configured. Configuring the hard disk drive controller next.

Checkpoint	Code	Description
95h		Initializing the bus option ROMs from C800 next. See the last page of this chapter for additional information.
96h		Initializing before passing control to the adaptor ROM at C800.
97h		Initialization before the C800 adaptor ROM gains control has completed. The adaptor ROM check is next.
98h		The adaptor ROM had control and has now returned control to BIOS POST. Performing any required processing after the option ROM returned control.
99h		Any initialization required after the option ROM test has completed. Configuring the timer data area and printer base address next.
9Ah		Set the timer and printer base addresses. Setting the RS-232 base address next.
9Bh		Returned after setting the RS-232 base address. Performing any required initialization before the Coprocessor test next.
9Ch		Required initialization before the Coprocessor test is over. Initializing the Coprocessor next.
9Dh		Coprocessor initialized. Performing any required initialization after the Coprocessor test next.
9Eh		Initialization after the Coprocessor test is complete. Checking the extended keyboard, keyboard ID, and Num Lock key next. Issuing the keyboard ID command next.
A2h		Displaying any soft errors next.
A3h		The soft error display has completed. Setting the keyboard typematic rate next.
A4h		The keyboard typematic rate is set. Programming the memory wait states next.
A5h		Memory wait state programming is over. Clearing the screen and enabling parity and the NMI next.
A7h		NMI and parity enabled. Performing any initialization required before passing control to the adaptor ROM at E000 next.
A8h		Initialization before passing control to the adaptor ROM at E000h completed. Passing control to the adaptor ROM at E000h next.
A9h		Returned from adaptor ROM at E000h control. Performing any initialization required after the E000 option ROM had control next.
Aah		Initialization after E000 option ROM control has completed. Displaying the system configuration next.
Abh		Uncompressing the DMI data and executing DMI POST initialization next.
B0h		The system configuration is displayed.
B1h		Copying any code to specific areas.
00h		Code copying to specific areas is done. Passing control to INT 19h boot loader next.

Notes