

SUPERO®

SUPERSERVER 6024H-8R SUPERSERVER 6024H-i

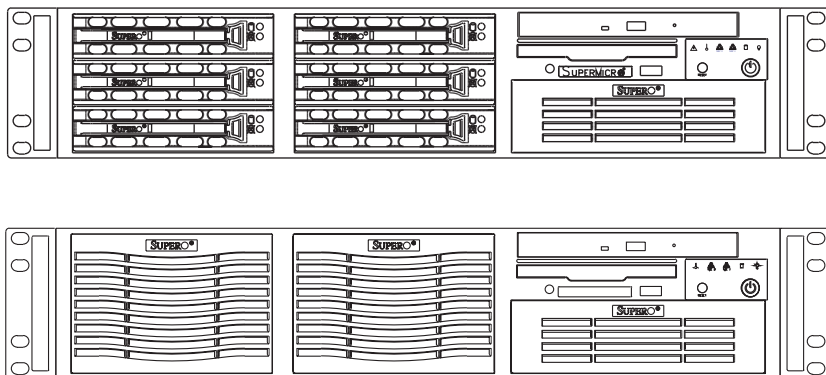

USER'S MANUAL

The information in this User's Manual has been carefully reviewed and is believed to be accurate. The vendor assumes no responsibility for any inaccuracies that may be contained in this document, makes no commitment to update or to keep current the information in this manual, or to notify any person or organization of the updates. **Please Note: For the most up-to-date version of this manual, please see our web site at www.supermicro.com.**

SUPERMICRO COMPUTER reserves the right to make changes to the product described in this manual at any time and without notice. This product, including software, if any, and documentation may not, in whole or in part, be copied, photocopied, reproduced, translated or reduced to any medium or machine without prior written consent.

IN NO EVENT WILL SUPERMICRO COMPUTER BE LIABLE FOR DIRECT, INDIRECT, SPECIAL, INCIDENTAL, SPECULATIVE OR CONSEQUENTIAL DAMAGES ARISING FROM THE USE OR INABILITY TO USE THIS PRODUCT OR DOCUMENTATION, EVEN IF ADVISED OF THE POSSIBILITY OF SUCH DAMAGES. IN PARTICULAR, THE VENDOR SHALL NOT HAVE LIABILITY FOR ANY HARDWARE, SOFTWARE, OR DATA STORED OR USED WITH THE PRODUCT, INCLUDING THE COSTS OF REPAIRING, REPLACING, INTEGRATING, INSTALLING OR RECOVERING SUCH HARDWARE, SOFTWARE, OR DATA.

Any disputes arising between manufacturer and customer shall be governed by the laws of Santa Clara County in the State of California, USA. The State of California, County of Santa Clara shall be the exclusive venue for the resolution of any such disputes. Supermicro's total liability for all claims will not exceed the price paid for the hardware product.

Unless you request and receive written permission from SUPER MICRO COMPUTER, you may not copy any part of this document.

Information in this document is subject to change without notice. Other products and companies referred to herein are trademarks or registered trademarks of their respective companies or mark holders.

Preface

About This Manual

This manual is written for professional system integrators and PC technicians. It provides information for the installation and use of the SuperServer 6024H-8R/6024H-i. Installation and maintenance should be performed by experienced technicians only.

The SuperServer 6024H-8R/6024H-i is a high-end server based on the SC823S-R500LP/SC823i-550LP 2U rackmount chassis and the Super X6DH8-G/X6DHE-G a dual processor serverboard that supports Intel® Xeon™ processors at a Front Side (System) Bus speed of 800 MHz and up to 16/32 GB of registered ECC DDR333/266 SDRAM.

Manual Organization

Chapter 1: Introduction

The first chapter provides a checklist of the main components included with the server system and describes the main features of the X6DH8-G/X6DHE-G serverboard and the SC823S-R500LP/SC823i-550LP chassis, which comprise the SuperServer 6024H-8R/6024H-i.

Chapter 2: Server Installation

This chapter describes the steps necessary to install the SuperServer 6024H-8R/6024H-i into a rack and check out the server configuration prior to powering up the system. If your server was ordered without processor and memory components, this chapter will refer you to the appropriate sections of the manual for their installation.

Chapter 3: System Interface

Refer here for details on the system interface, which includes the functions and information provided by the control panel on the chassis as well as other LEDs located throughout the system.

Chapter 4: System Safety

You should thoroughly familiarize yourself with this chapter for a general overview of safety precautions that should be followed when installing and servicing the SuperServer 6024H-8R/6024H-i.

Chapter 5: Advanced Serverboard Setup

Chapter 5 provides detailed information on the X6DH8-G/X6DHE-G serverboard, including the locations and functions of connections, headers and jumpers. Refer to this chapter when adding or removing processors or main memory and when reconfiguring the serverboard.

Chapter 6: Advanced Chassis Setup

Refer to Chapter 6 for detailed information on the SC823S-R500LP/SC823i-550LP server chassis. You should follow the procedures given in this chapter when installing, removing or reconfiguring SCSI/IDE or peripheral drives and when replacing system power supply units and cooling fans.

Chapter 7: BIOS

The BIOS chapter includes an introduction to BIOS and provides detailed information on running the CMOS Setup Utility.

Appendix A: BIOS POST Codes

Appendix B: Software Installation

Appendix C: System Specifications

Notes

Table of Contents

Preface

About This Manual	iii
Manual Organization	iii

Chapter 1: Introduction

1-1 Overview	1-1
1-2 Serverboard Features	1-2
1-3 Server Chassis Features	1-3
1-4 Contacting Supermicro	1-6

Chapter 2: Quick Setup

2-1 Overview	2-1
2-2 Unpacking the System	2-1
2-3 Preparing for Setup	2-1
2-4 Installing the System into a Rack	2-4
2-5 Checking the Serverboard Setup	2-8
2-6 Checking the Drive Bay Setup	2-10

Chapter 3: System Interface

3-1 Overview	3-1
3-2 Control Panel Buttons	3-1
Reset	3-1
Power	3-1
3-3 Control Panel LEDs	3-2
Power Fail	3-2
Overheat/Fan Fail	3-2
NIC1	3-2
NIC2	3-3
HDD	3-3
Power	3-3
3-4 SCSI Drive Carrier LEDs	3-3

Chapter 4: System Safety

4-1 Electrical Safety Precautions	4-1
4-2 General Safety Precautions	4-2
4-3 ESD Safety Precautions	4-3
4-4 Operating Precautions	4-4

Chapter 5: Advanced Serverboard Setup

5-1	Handling the Serverboard	5-1
5-2	Processor and Heatsink Installation	5-2
5-3	Connecting Cables	5-4
	Connecting Data Cables	5-4
	Connecting Power Cables	5-4
	Connecting the Control Panel	5-5
5-4	I/O Ports	5-6
5-5	Installing Memory	5-6
5-6	Adding PCI Cards	5-8
5-7	Serverboard Details	5-9
	X6DH8-G/X6DHE-G Layout	5-9
	X6DH8-G/X6DHE-G Quick Reference	5-10
5-8	Connector Definitions	5-11
	ATX Power Connector	5-11
	Processor Power Connector	5-11
	NMI Button	5-11
	Power LED	5-11
	HDD LED	5-12
	NIC1/NIC2 LED	5-12
	Overheat/Fan Fail LED	5-12
	Power Fail LED	5-12
	Reset Button	5-13
	Power Button	5-13
	Chassis Intrusion	5-13
	Universal Serial Bus (USB0/1)	5-13
	Fan Headers	5-14
	Serial Ports	5-14
	ATX PS/2 Keyboard and Mouse Ports	5-14
	LAN 1/2 (Ethernet Ports)	5-14
	Power LED/Speaker/NMI	5-15
	Wake-On-Ring	5-15
	Wake-On-LAN	5-15
	Power Fail	5-16
	SMB	5-16
	SMB Power	5-16
	Overheat LED	5-16

5-9	Jumper Settings	5-17
	Explanation of Jumpers	5-17
	CMOS Clear	5-17
	LAN1 Enable/Disable	5-18
	LAN2 Enable/Disable	5-18
	SCSI Controller Enable/Disable	5-18
	Watch Dog Enable/Disable	5-19
	Power Force On Enable/Disable	5-19
	VGA Enable/Disable	5-19
	Third Power Supply Alarm Enable/Disable	5-20
	Alarm Reset	5-20
5-10	Onboard Indicators	5-21
	LAN1/LAN2 LEDs	5-21
5-11	Parallel Port, Floppy/Hard Disk Drive and SCSI Connections	5-21
	Parallel Port Connector	5-21
	Floppy Connector	5-22
	IDE Connectors	5-22
	Ultra320 SCSI Connectors	5-23

Chapter 6: Advanced Chassis Setup

6-1	Static-Sensitive Devices	6-1
6-2	Control Panel	6-3
6-3	System Fans	6-3
	System Fan Failure	6-3
	Replacing System Fans	6-3
6-4	Drive Bay Installation/Removal	6-4
	SCSI Drive Installation	6-5
	IDE Drive Installation	6-8
	Installing a Component in the 5.25" Drive Bay	6-8
	CD-ROM and Floppy Drive Installation	6-10
6-5	Power Supply: 6024H-8R	6-11
	Power Supply Failure	6-11
	Removing/Replacing the Power Supply	6-11
6-6	Power Supply: 6024H-i	6-12
	Power Supply Failure	6-12
	Removing/Replacing the Power Supply	6-12

Chapter 7: BIOS

7-1	Introduction	7-1
7-2	Running Setup	7-2
7-3	Main BIOS Setup	7-2
7-4	Advanced Setup	7-8
7-5	Security	7-19
7-6	Boot	7-21
7-7	Exit	7-22

Appendices:

Appendix A:	BIOS POST Codes	A-1
Appendix B:	Software Installation	B-1
Appendix C:	System Specifications	C-1

Notes

Chapter 1

Introduction

1-1 Overview

The Supermicro SuperServer 6024H-8R/6024H-i is a high-end server that is comprised of two main subsystems: the SC823S-R500LP/SC823i-550LP 2U server chassis and the X6DH8-G/X6DHE-G Intel Xeon dual processor serverboard. Please refer to our web site for information on operating systems that have been certified for use with the SuperServer 6024H-8R/6024H-i (www.supermicro.com).

In addition to the serverboard and chassis, various hardware components have been included with the SuperServer 6024H-8R/6024H-i, as listed below:

- One (1) 3.5" floppy drive [FPD-PNSC-02(1)]
- One (1) slim CD-ROM drive [CDM-TEAC-24(B)]
- Four (4) 8-cm hot-swap chassis fans (FAN-0070)
- One (1) 2U chassis air shroud (CSE-PT47)
- One (1) 5.25" dummy drive tray [CSE-PT41(B)]
- One (1) front control panel cable (CBL-0049)
- SCSI Accessories (6024H-8R only)
 - One (1) SCSI backplane [CSE-SCA-822S]
 - One (1) 9" two-drop SCSI cable (CBL-0033-U320)
 - Six (6) SCA 1-inch high SCSI drive carriers [CSE-PT17(B)]
- IDE Accessories (6024H-i only)
 - Two (2) IDE drive carriers [CSE-PT18(B)]
 - One (1) IDE cable (CBL-0036)
- One (1) rackmount kit [CSE-PT025(B)]
- Optional: One (1) front access USB kit [CSE-PT29(B)]
 - Two (2) CPU passive heatsinks (SNK-P0010)

1-2 Serverboard Features

At the heart of the SuperServer 6024H-8R/6024H-i lies the X6DH8-G/X6DHE-G, a dual processor serverboard based on the Intel E7520 chipset and designed to provide maximum performance. Below are the main features of the X6DH8-G/X6DHE-G. (See Figure 1-1 for a block diagram of the E7520 chipset).

Processors

The X6DH8-G/X6DHE-G supports single or dual 604-pin Intel Xeon EM64T type processors at a FSB speed of 800 MHz. Please refer to the serverboard description pages on our web site for a complete listing of supported processors (www.supermicro.com).

Memory

The X6DH8-G/X6DHE-G has eight 184-pin DIMM slots that can support up to 16 GB of registered ECC DDR333 or up to 32 GB of registered ECC DDR266 SDRAM. The memory is an interleaved configuration, which requires modules of the same size and speed to be installed in pairs.

Onboard SCSI (6024H-8R only)

Onboard SCSI is provided with an Adaptec AIC-7902 SCSI chip, which supports dual channel, Ultra320 SCSI at a throughput of 320 MB/sec for each channel. The X6DH8-G provides two LVD Ultra320 SCSI ports.

PCI Expansion Slots

The X6DH8-G/X6DHE-G has six PCI expansion slots, which includes two x8 PCI-Express slots, one 64-bit 133 MHz PCI-X slot, two 64-bit 100 MHz PCI-X slots and one 32-bit 33 MHz PCI slot. (One 100 MHz PCI slot supports Zero Channel RAID.)

Onboard Controllers/Ports

One floppy drive controller and two onboard ATA/100 controllers are provided to support up to four IDE hard drives or ATAPI devices. The color-coded I/O ports include one COM port (an additional COM header is located on the serverboard), a VGA (monitor) port, a parallel port, two USB 2.0

ports, PS/2 mouse and keyboard ports and two gigabit Ethernet ports. Two front side USB ports are also included on the front of the chassis.

ATI Graphics Controller

The X6DH8-G/X6DHE-G features an integrated ATI video controller based on the Rage XL graphics chip. Rage XL fully supports sideband addressing and AGP texturing. This onboard graphics package can provide a bandwidth of up to 512 MB/sec over a 32-bit graphics memory bus.

Other Features

Other onboard features that promote system health include onboard voltage monitors, a chassis intrusion header, auto-switching voltage regulators, chassis and CPU overheat sensors, virus protection and BIOS rescue.

1-3 Server Chassis Features

The SuperServer 6024H-8R/6024H-i is a high-end, scaleable server platform designed with today's most state-of-the-art features. The following is a general outline of the main features of the SC823S-R500LP/SC823i-550LP server chassis.

System Power

6024H-8R: the SC823S-R500LP features a redundant 500W power supply that consists of two separate power supply modules. Under normal operation, both modules share the load and run continuously. If one fails, the other module will pick up the load and keep the system running without interruption. A failed power supply module will illuminate the power fail LED. The power supply modules are hot-swappable, so you don't have to power down the system to replace a module.

6024H-i: the SC823i-550LP features a single 550W power supply. Power must be removed from the system before servicing or replacing this power supply.

SCSI Subsystem (6024H-8R only)

The SCSI subsystem supports up to six 80-pin SCA Ultra320 SCSI hard drives. Any standard 1" drives are supported. SCA = Single Connection Attachment.) The SCSI drives are connected to an SCA backplane with SAF-TE. The SCSI drives are also hot-swap units. A RAID controller card can be used with the SCA backplane to provide data security.

Note: The operating system you use must have RAID support to enable the hot-swap capability of the SCSI drives.

Front Control Panel

The SuperServer 6024H-8R/6024H-i's control panel provides you with system monitoring and control. LEDs indicate system power, HDD activity, network activity, system overheat and (on the 6024H-8R only) power supply failure. A main power button and a system reset button are also included.

I/O Backplane

The SC823S-R500LP/SC823i-550LP is an ATX form factor chassis that is designed to be used in a 2U rackmount configuration. The I/O backplane provides seven low-profile motherboard expansion slots (with the use of special riser cards), one COM port, a parallel port, a VGA port, four USB 2.0 ports, PS/2 mouse and keyboard ports and two gigabit Ethernet ports.

Cooling System

The SC823S-R500LP/SC823i-550LP chassis has an innovative cooling design that includes four 8-cm hot-plug system cooling fans located in the middle section of the chassis. An air shroud channels the air flow from these fans to efficiently cool the processor area of the system. The power supply module(s) also includes a cooling fan.

**Figure 1-1. Intel E7520 Chipset:
System Block Diagram**

Note: This is a general block diagram. Please see Chapter 5 for details.

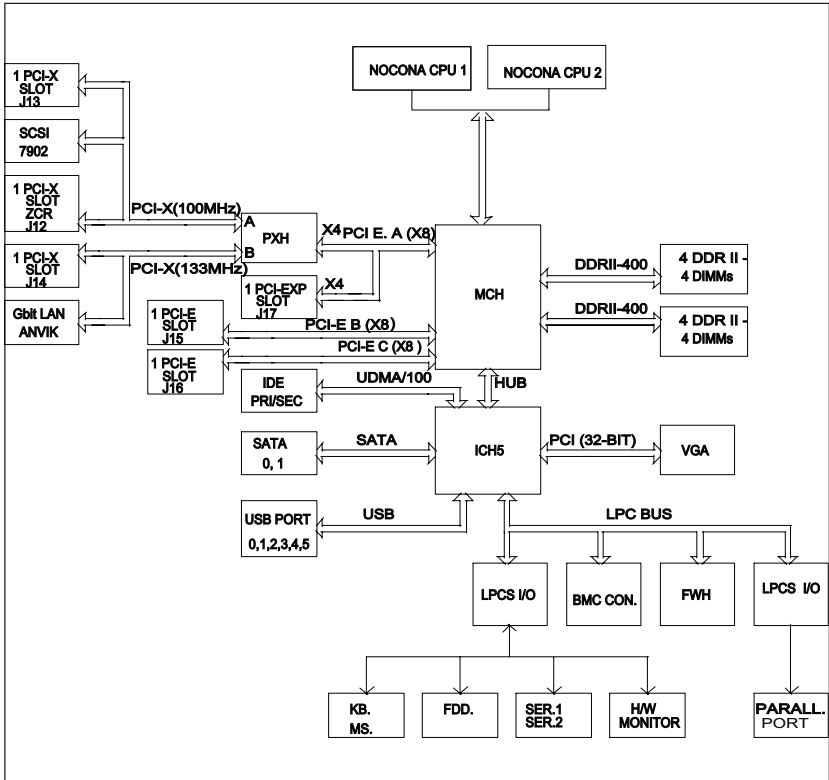

1-4 Contacting Supermicro

Headquarters

Address: SuperMicro Computer, Inc.
980 Rock Ave.
San Jose, CA 95131 U.S.A.

Tel: +1 (408) 503-8000

Fax: +1 (408) 503-8008

Email: marketing@supermicro.com (General Information)
support@supermicro.com (Technical Support)

Web Site: www.supermicro.com

Europe

Address: SuperMicro Computer B.V.
Het Sterrenbeeld 28, 5215 ML
's-Hertogenbosch, The Netherlands

Tel: +31 (0) 73-6400390

Fax: +31 (0) 73-6416525

Email: sales@supermicro.nl (General Information)
support@supermicro.nl (Technical Support)
rma@supermicro.nl (Customer Support)

Asia-Pacific

Address: SuperMicro, Taiwan
D5, 4F, No. 16 Chien-Ba Road
Chung-Ho 235, Taipei Hsien, Taiwan, R.O.C.

Tel: +886-(2) 8226-3990

Fax: +886-(2) 8226-3991

Web Site: www.supermicro.com.tw

Technical Support:

Email: support@supermicro.com.tw

Tel: 886-2-8228-1366, ext.132 or 139

Chapter 2

Server Installation

2-1 Overview

This chapter provides a quick setup checklist to get your SuperServer 6024H-8R/6024H-i up and running. Following these steps in the order given should enable you to have the system operational within a minimum amount of time. This quick setup assumes that your system has come to you with the processors and memory preinstalled. If your system is not already fully integrated with a serverboard, processors, system memory etc., please turn to the chapter or section noted in each step for details on installing specific components.

2-2 Unpacking the System

You should inspect the box the SuperServer 6024H-8R/6024H-i was shipped in and note if it was damaged in any way. If the server itself shows damage you should file a damage claim with the carrier who delivered it.

Decide on a suitable location for the rack unit that will hold the SuperServer 6024H-8R/6024H-i. It should be situated in a clean, dust-free area that is well ventilated. Avoid areas where heat, electrical noise and electromagnetic fields are generated. You will also need it placed near a grounded power outlet. Read the Rack and Server Precautions in the next section.

2-3 Preparing for Setup

The box the SuperServer 6024H-8R/6024H-i was shipped in should include two sets of rail assemblies, two rail mounting brackets and the mounting screws you will need to install the system into the rack. Follow the steps in the order given to complete the installation process in a minimum amount of time. Please read this section in its entirety before you begin the installation procedure outlined in the sections that follow.

Choosing a Setup Location

- Leave enough clearance in front of the rack to enable you to open the front door completely (~25 inches).
- Leave approximately 30 inches of clearance in the back of the rack to allow for sufficient airflow and ease in servicing.



Warnings and Precautions!



Rack Precautions

- Ensure that the leveling jacks on the bottom of the rack are fully extended to the floor with the full weight of the rack resting on them.
- In single rack installation, stabilizers should be attached to the rack.
- In multiple rack installations, the racks should be coupled together.
- Always make sure the rack is stable before extending a component from the rack.
- You should extend only one component at a time - extending two or more simultaneously may cause the rack to become unstable.

Server Precautions

- Review the electrical and general safety precautions in Chapter 4.
- Determine the placement of each component in the rack *before* you install the rails.
- Install the heaviest server components on the bottom of the rack first, and then work up.
- Use a regulating uninterruptible power supply (UPS) to protect the server from power surges, voltage spikes and to keep your system operating in case of a power failure.
- Allow the hot plug SCSI drives and power supply units to cool before touching them.
- Always keep the rack's front door and all panels and components on the servers closed when not servicing to maintain proper cooling.

Rack Mounting Considerations

Ambient Operating Temperature

If installed in a closed or multi-unit rack assembly, the ambient operating temperature of the rack environment may be greater than the ambient temperature of the room. Therefore, consideration should be given to installing the equipment in an environment compatible with the manufacturer's maximum rated ambient temperature (T_{mra}).

Reduced Airflow

Equipment should be mounted into a rack so that the amount of airflow required for safe operation is not compromised.

Mechanical Loading

Equipment should be mounted into a rack so that a hazardous condition does not arise due to uneven mechanical loading.

Circuit Overloading

Consideration should be given to the connection of the equipment to the power supply circuitry and the effect that any possible overloading of circuits might have on overcurrent protection and power supply wiring. Appropriate consideration of equipment nameplate ratings should be used when addressing this concern.

Reliable Ground

A reliable ground must be maintained at all times. To ensure this, the rack itself should be grounded. Particular attention should be given to power supply connections other than the direct connections to the branch circuit (i.e. the use of power strips, etc.).

2-4 Installing the System into a Rack

This section provides information on installing the SuperServer 6024H-8R/6024H-i into a rack unit. If the 6024H-8R/6024H-i has already been mounted into a rack, you can skip ahead to Sections 2-5 and 2-6. There are a variety of rack units on the market, which may mean the assembly procedure will differ slightly. The following is a guideline for installing the 6024H-8R/6024H-i into a rack with the rack rails provided. You should also refer to the installation instructions that came with the rack unit you are using.

Identifying the Sections of the Rack Rails

You should have received two rack rail assemblies with the SuperServer 6024H-8R/6024H-i. Each of these assemblies consist of two sections: an inner fixed chassis rail that secures to the 6024H-8R/6024H-i (A) and an outer fixed rack rail that secures directly to the rack itself (B). All screws and hardware mentioned in the installation steps should be included in the hardware kit.

To remove the fixed chassis rail (A), pull it out as far as possible - you should hear a "click" sound as a locking tab emerges from inside the rail assembly and locks the inner rail. Then depress the locking tab to pull the inner rail completely out. Do this for both the left and right side rack rail assemblies.

Figure 2-1. Identifying the Sections of the Rack Rails

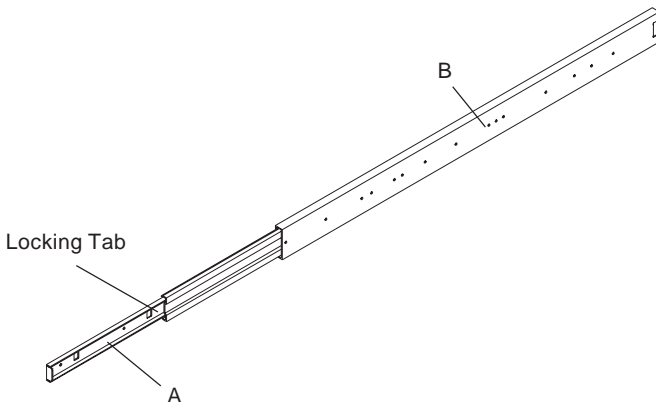

Installing the Chassis Rails

Position the fixed chassis rail sections you just removed along the side of the 6024H-8R/6024H-i making sure the screw holes line up. Note that these two rails are left/right specific. Screw the rail securely to the side of the chassis (see Figure 2-2). Repeat this procedure for the other rail on the other side of the chassis. You will also need to attach the rail brackets when installing into a telco rack.

Locking Tabs: As mentioned, both chassis rails have a locking tab, which serves two functions. The first is to lock the server into place when installed and pushed fully into the rack, which is its normal position. Secondly, these tabs also lock the server in place when fully extended from the rack. This prevents the server from coming completely out of the rack when you pull it out for servicing.

Figure 2-2. Installing Chassis Rails

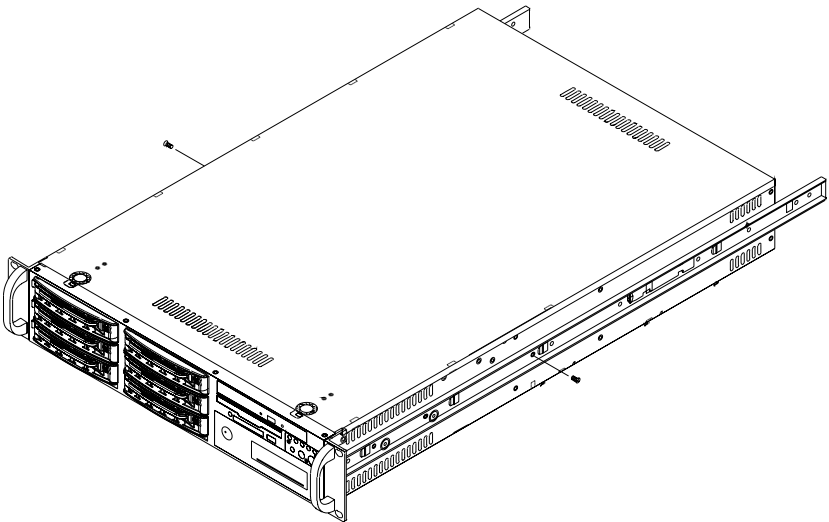

Installing the Rack Rails:

Determine where you want to place the SuperServer 6024H-8R/6024H-i in the rack. (See Rack and Server Precautions in Section 2-3.) Position the fixed rack rail/sliding rail guide assemblies at the desired location in the rack, keeping the sliding rail guide facing the inside of the rack. Screw the assembly securely to the rack using the brackets provided. Attach the other assembly to the other side of the rack, making sure both are at the exact same height and with the rail guides facing inward (see Figure 2-3).

Figure 2-3. Assembling the Rack Rails

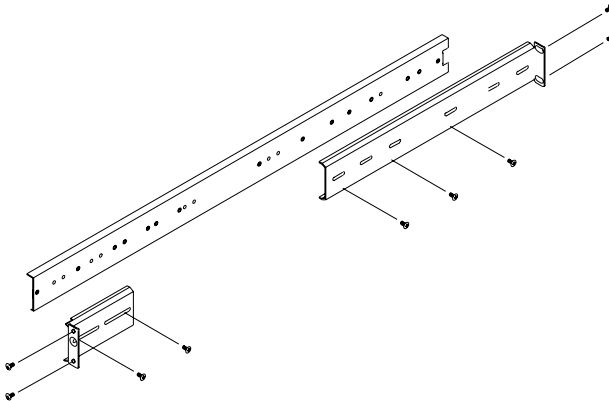

Installing the Server into the Rack

You should now have rails attached to both the chassis and the rack unit. The next step is to install the server into the rack. Do this by lining up the rear of the chassis rails with the front of the rack rails. Slide the chassis rails into the rack rails, keeping the pressure even on both sides (you may have to depress the locking tabs when inserting). See Figure 2-4.

When the server has been pushed completely into the rack, you should hear the locking tabs "click". Finish by inserting and tightening the thumbscrews that hold the front of the server to the rack.

Figure 2-4. Installing the Server into a Rack

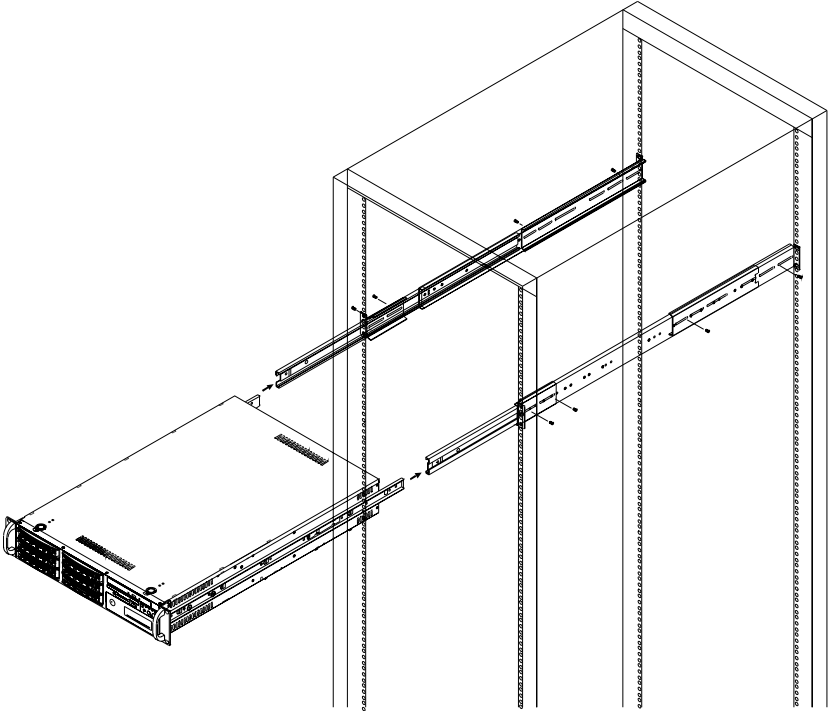

Installing the Server into a Telco Rack

If you are installing the SuperServer 6024H-8R/6024H-i into a Telco type rack, follow the directions given on the previous pages for rack installation. The only difference in the installation procedure will be the positioning of the rack brackets to the rack. They should be spaced apart just enough to accommodate the width of the telco rack.

2-5 Checking the Serverboard Setup

After you install the 6024H-8R/6024H-i in the rack, you will need to open the unit to make sure the serverboard is properly installed and all the connections have been made.

1. Accessing the inside of the System (see Figure 2-5):

First, release the retention screws that secure the unit to the rack. Grasp the two handles on either side and pull the unit straight out until it locks (you will hear a "click"). Next, depress the two buttons on the top of the chassis to release the top cover. You can then lift the top cover from the chassis to gain full access to the inside of the server.

2. Check the CPUs (processors):

You may have one or two processors already installed into the serverboard. Each processor needs its own heatsink. See Chapter 5 for instructions on processor and heatsink installation.

3. Check the system memory:

Your 6024H-8R/6024H-i server system may have come with system memory already installed. Make sure all DIMMs are fully seated in their slots. For details on adding system memory, refer to Chapter 5.

4. Installing add-on cards:

If desired, you can install add-on cards to the system. See Chapter 5 for details on installing PCI add-on cards.

5. Check all cable connections and airflow:

Make sure all power and data cables are properly connected and not blocking the chassis airflow. Also make sure that no cables are positioned in front of the fans. See Chapter 5 for details on cable connections.

Figure 2-5. Accessing the Inside of the System

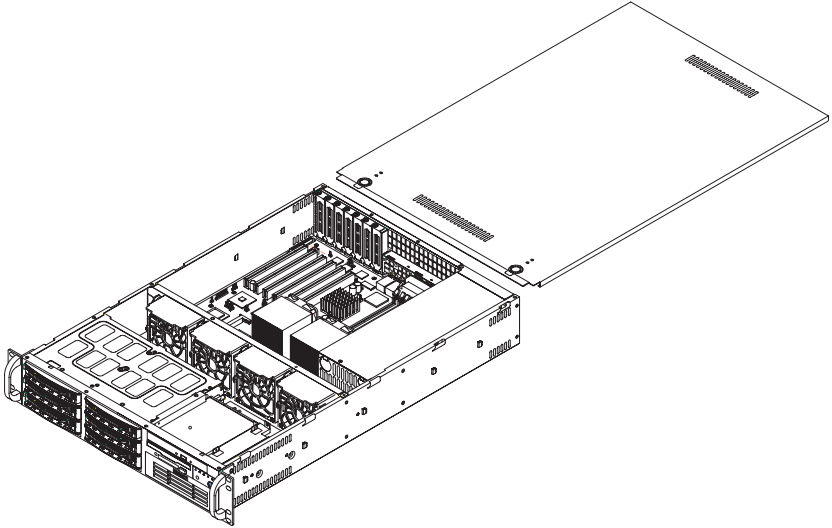

2-6 Checking the Drive Bay Setup

Next, you should check to make sure the peripheral drives and the SCSI drives and SCA backplane have been properly installed and all connections have been made.

1. Accessing the drive bays:

All drives are accessible from the front of the server. For servicing the CD-ROM and floppy drives, you will need to remove the top chassis cover. The SCSI disk drives can be installed and removed from the front of the chassis without removing the top chassis cover.

2. CD-ROM and floppy disk drives:

A slim CD-ROM and a floppy drive should be preinstalled in your server. Refer to Chapter 6 if you need to reinstall a CD-ROM and/or floppy disk drive to the system.

3. Check the SCSI disk drives (6024H-8R only):

Depending upon your system's configuration, your system may have one or more drives already installed. If you need to install SCSI drives, please refer to Chapter 6.

4. Check the airflow:

Airflow is provided by four 8-cm center chassis cooling fans. An air shroud is also included in the system to maximize airflow. The system component layout was carefully designed to direct sufficient cooling airflow to the components that generate the most heat. Note that all power and data cables have been routed in such a way that they do not block the airflow generated by the fans.

5. Supplying power to the system:

The last thing you must do is to provide input power to the system. Plug the power cords from the power supply units into a high-quality power strip that offers protection from electrical noise and power surges. It is recommended that you use an uninterruptible power supply (UPS).

Chapter 3

System Interface

3-1 Overview

There are several LEDs on the control panel as well as others on the SCSI drive carriers (6024H-8R only) to keep you constantly informed of the overall status of the system as well as the activity and health of specific components. There are also two buttons on the chassis control panel.

3-2 Control Panel Buttons

The two push-buttons located on the front of the chassis are (in order from left to right) a reset button and a power on/off button.

RESET



- **RESET:** Use the reset button to reboot the system.



- **POWER:** This is the main power button, which is used to apply or turn off the main system power. Turning off system power with this button removes the main power but keeps standby power supplied to the system.

3-3 Control Panel LEDs

The control panel located on the front of the chassis has five LEDs. These LEDs provide you with critical information related to different parts of the system. This section explains what each LED indicates when illuminated and any corrective action you may need to take.



- **Power Fail:** Indicates a power supply module has failed. The second power supply module will take the load and keep the system running but the failed module will need to be replaced. Refer to Chapter 6 for details on replacing the power supply. This LED should be off when the system is operating normally. Note: the Power Fail LED applies only to the 6024H-8R. It is not needed for the 6024H-i, which has only a single power supply.



- **Overheat/Fan Fail:** When this LED flashes, it indicates a fan failure. When on continuously it indicates an overheat condition, which may be caused by cables obstructing the airflow in the system or the ambient room temperature being too warm. Check the routing of the cables and make sure all fans are present and operating normally. You should also check to make sure that the chassis covers are installed. Finally, verify that the heatsinks are installed properly (see Chapter 5). This LED will remain flashing or on as long as the indicated condition exists.



- **NIC1:** Indicates network activity on the LAN1 port when flashing.



- **NIC2:** Indicates network activity on the LAN2 port when flashing.



- **HDD:** Indicates IDE channel activity. On the SuperServer 6024H-8R/6024H-i, this LED indicates SCSI and CD-ROM/IDE and CD-ROM drive activity when flashing.



- **Power:** Indicates power is being supplied to the system's power supply units. This LED should normally be illuminated when the system is operating.

3-4 SCSI Drive Carrier LEDs (6024H-8R only)

A SCSI drive carrier has two LEDs.

- **Green:** When illuminated, the green LED on the front of the SCSI drive carrier indicates drive activity. A connection to the SCSI SCA backplane enables this LED to blink on and off when that particular drive is being accessed.
- **Red:** A SAF-TE compliant backplane is needed to activate the red LED, which indicates a drive failure. (A SAF-TE compliant SCSI backplane is standard on the 6024H-8R.) If one of the SCSI drives fail, you should be notified by your system management software. Please refer to Chapter 6 for instructions on replacing failed SCSI drives.

Notes

Chapter 4

System Safety

4-1 Electrical Safety Precautions



Basic electrical safety precautions should be followed to protect yourself from harm and the SuperServer 6024H-8R/6024H-i from damage:

- Be aware of the locations of the power on/off switch on the chassis as well as the room's emergency power-off switch, disconnection switch or electrical outlet. If an electrical accident occurs, you can then quickly remove power from the system.
- Do not work alone when working with high voltage components.
- Power should always be disconnected from the system when removing or installing main system components, such as the serverboard, memory modules and the CD-ROM and floppy drives. When disconnecting power, you should first power down the system with the operating system and then unplug the power cords of all the power supply units in the system.
- When working around exposed electrical circuits, another person who is familiar with the power-off controls should be nearby to switch off the power if necessary.
- Use only one hand when working with powered-on electrical equipment. This is to avoid making a complete circuit, which will cause electrical shock. Use extreme caution when using metal tools, which can easily damage any electrical components or circuit boards they come into contact with.
- Do not use mats designed to decrease electrostatic discharge as protection from electrical shock. Instead, use rubber mats that have been specifically designed as electrical insulators.
- The power supply power cord must include a grounding plug and must be plugged into grounded electrical outlets.

- Serverboard Battery: **CAUTION** - There is a danger of explosion if the onboard battery is installed upside down, which will reverse its polarities. This battery must be replaced only with the same or an equivalent type recommended by the manufacturer. Dispose of used batteries according to the manufacturer's instructions.
- CD-ROM Laser: **CAUTION** - this server may have come equipped with a CD-ROM drive. To prevent direct exposure to the laser beam and hazardous radiation exposure, do not open the enclosure or use the unit in any unconventional way.

4-2 General Safety Precautions



Follow these rules to ensure general safety:

- Keep the area around the SuperServer 6024H-8R/6024H-i clean and free of clutter.
- The SuperServer 6024H-8R/6024H-i weighs approximately 57/54 lbs (25.6/24.5 kg.) when fully loaded. When lifting the system, two people at either end should lift slowly with their feet spread out to distribute the weight. Always keep your back straight and lift with your legs. Don't use the handles to lift the chassis; the handles should only be used to pull the server out of the rack.
- Place the chassis top cover and any system components that have been removed away from the system or on a table so that they won't accidentally be stepped on.
- While working on the system, do not wear loose clothing such as neckties and unbuttoned shirt sleeves, which can come into contact with electrical circuits or be pulled into a cooling fan.
- Remove any jewelry or metal objects from your body, which are excellent metal conductors that can create short circuits and harm you if they come into contact with printed circuit boards or areas where power is present.

- After accessing the inside of the system, close the system back up and secure it to the rack unit with the retention screws after ensuring that all connections have been made.

4-3 ESD Precautions



Electrostatic discharge (ESD) is generated by two objects with different electrical charges coming into contact with each other. An electrical discharge is created to neutralize this difference, which can damage electronic components and printed circuit boards. The following measures are generally sufficient to neutralize this difference before contact is made to protect your equipment from ESD:

- Use a grounded wrist strap designed to prevent static discharge.
- Keep all components and printed circuit boards (PCBs) in their antistatic bags until ready for use.
- Touch a grounded metal object before removing the board from the antistatic bag.
- Do not let components or PCBs come into contact with your clothing, which may retain a charge even if you are wearing a wrist strap.
- Handle a board by its edges only; do not touch its components, peripheral chips, memory modules or contacts.
- When handling chips or modules, avoid touching their pins.
- Put the serverboard and peripherals back into their antistatic bags when not in use.
- For grounding purposes, make sure your computer chassis provides excellent conductivity between the power supply, the case, the mounting fasteners and the serverboard.

4-4 Operating Precautions



Care must be taken to assure that the chassis cover is in place when the 6024H-8R/6024H-i is operating to assure proper cooling. Out of warranty damage to the 6024H-8R/6024H-i system can occur if this practice is not strictly followed.

Chapter 5

Advanced Serverboard Setup

This chapter covers the steps required to install processors and heatsinks to the X6DH8-G/X6DHE-G serverboard, connect the data and power cables and install add-on cards. All serverboard jumpers and connections are described and a layout and quick reference chart are included in this chapter. Remember to close the chassis completely when you have finished working on the serverboard to protect and cool the system sufficiently.

5-1 Handling the Serverboard

Static electrical discharge can damage electronic components. To prevent damage to printed circuit boards, it is important to handle them very carefully (see Chapter 4). Also note that the size and weight of the serverboard can cause it to bend if handled improperly, which may result in damage. To prevent the serverboard from bending, keep one hand under the center of the board to support it when handling. The following measures are generally sufficient to protect your equipment from static discharge.

Precautions

- Use a grounded wrist strap designed to prevent static discharge.
- Touch a grounded metal object before removing any board from its anti-static bag.
- Handle a board by its edges only; do not touch its components, peripheral chips, memory modules or gold contacts.
- When handling chips or modules, avoid touching their pins.
- Put the serverboard, add-on cards and peripherals back into their anti-static bags when not in use.

Unpacking

The serverboard is shipped in antistatic packaging to avoid static damage. When unpacking the board, make sure the person handling it is static protected.

5-2 Processor and Heatsink Installation



When handling the processor package, avoid placing direct pressure on the label area of the fan. Also, do not place the serverboard on a conductive surface, which can damage the BIOS battery and prevent the system from booting up.

IMPORTANT: Always connect the power cord last and always remove it before adding, removing or changing any hardware components. Make sure that you install the processor into the CPU socket **before** you install the CPU heat sink.

CPU Installation

1. Lift the lever on the CPU socket: Lift the lever completely as shown on the picture on the right; otherwise, you will damage the CPU socket when power is applied. Install CPU1 first.



Socket lever

2. Insert the CPU in the socket, making sure that pin 1 of the CPU aligns with pin 1 of the socket (both corners are marked with a triangle). When using only one CPU, install it into CPU socket #1. (Socket #2 is automatically disabled if only one CPU is used.)



Pin 1

3. Press the lever down until you hear a *click*, which means the CPU is securely installed in the CPU socket. Repeat these steps if you wish to install a second CPU in socket#2.



Socket lever in the locking Position

Heatsink Installation

1. Do not apply any thermal compound to the heatsink or the CPU die; the required amount has already been applied.
2. Place the heatsink on top of the CPU so that the four mounting holes are aligned with those on the retention mechanism.
3. Screw in two diagonal screws (i.e. the #1 and the #2 screws) until just snug (do not fully tighten the screws to avoid possible damage to the CPU). Then screw in the other two diagonal screws until snug.
4. Finish the installation by fully tightening all four screws.

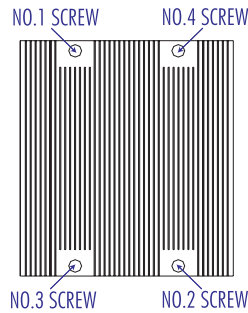
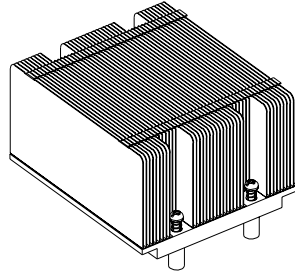

Note: the SNK-P0010 passive heatsink is an optional accessory.

Figure 5-1. 604-pin PGA Socket: Empty and with Processor Installed



Warning! Make sure you lift the lever completely when installing the CPU. If the lever is only partly raised, damage to the socket or CPU may result.

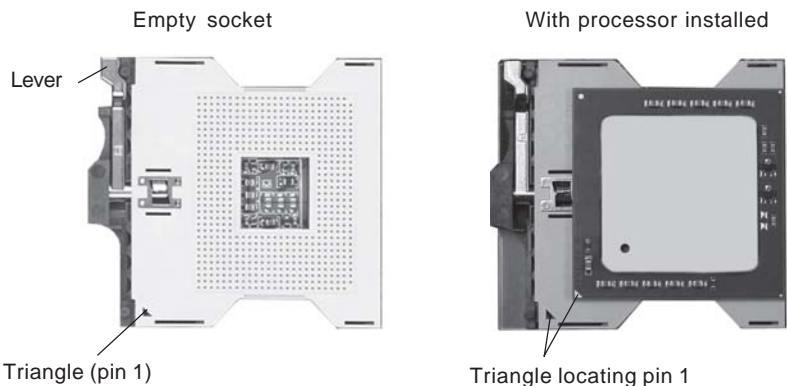

5-3 Connecting Cables

Now that the processors are installed, the next step is to connect the cables to the serverboard. These include the data (ribbon) cables for the peripherals and control panel and the power cables.

Connecting Data Cables

The ribbon cables used to transfer data from the peripheral devices have been carefully routed in preconfigured systems to prevent them from blocking the flow of cooling air that moves through the system from front to back. If you need to disconnect any of these cables, you should take care to keep them routed as they were originally after reconnecting them (make sure the red wires connect to the pin 1 locations). If you are configuring the system, keep the airflow in mind when routing the cables.

The following data cables (with their serverboard connector locations noted) should be connected. See the serverboard layout figure in this chapter for connector locations.

- Ultra320 LVD SCSI cable (JA1, 6024H-8R only)
- IDE#1 cable (J5, 6024H-i only)
- Control Panel cable (JF1, see next page)
- CD-ROM cable (J6)
- Floppy Drive Cable (J12)

Connecting Power Cables

The X6DH8-G/X6DHE-G has a 24-pin primary power supply connector designated "ATX_Power" (JPW1) for connection to the ATX power supply. Connect the appropriate connector from the power supply to the "ATX Power" connector to supply power to the serverboard. The 12V 8-pin processor power connector at J1D1 and the 12V 4-pin power connector at J38 must also both be connected to your power supply. See the Connector Definitions section in this chapter for power connector pin definitions.

Connecting the Control Panel

JF1 contains header pins for various front control panel connectors. See Figure 5-2 for the pin locations of the various front control panel buttons and LED indicators. Please note that even and odd numbered pins are on opposite sides of each header.

All JF1 wires have been bundled into single ribbon cable to simplify their connection. Make sure the red wire plugs into pin 1 as marked on the board. The other end connects to the Control Panel printed circuit board, located just behind the system status LEDs in the chassis.

See the Connector Definitions section in this chapter for details and pin descriptions of JF1.

Figure 5-2. JF1 Header Pins

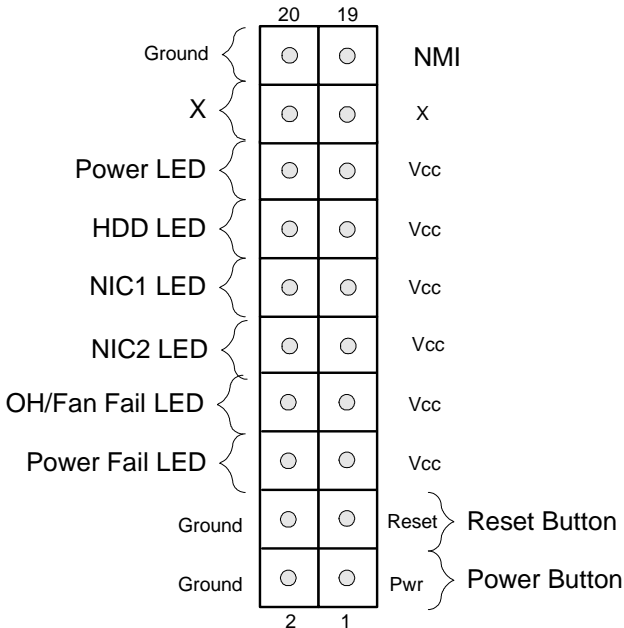

5-4 I/O Ports

The I/O ports are color coded in conformance with the PC 99 specification. See Figure 5-3 below for the colors and locations of the various I/O ports.

Figure 5-3. Rear Panel I/O Ports

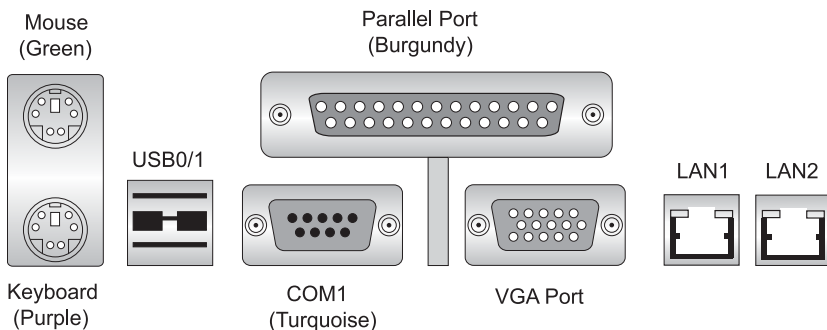

5-5 Installing Memory

Note: Check the Supermicro web site for recommended memory modules:
<http://www.supermicro.com/support/resources/>

CAUTION

Exercise extreme care when installing or removing DIMM modules to prevent any possible damage. Also note that the memory is interleaved to improve performance (see step 1).

DIMM Installation (See Figures 5-4 and 5-5)

1. Insert the desired number of DIMMs into the memory slots, starting with Bank #1A. The memory scheme is interleaved so you must install two modules at a time, beginning with DIMM #1A, then DIMM #1B, and so on.
2. Insert each DIMM module vertically into its slot. Pay attention to the notch along the bottom of the module to prevent inserting the DIMM module incorrectly.
3. Gently press down on the DIMM module until it snaps into place in the slot. Repeat for all modules (see step 1 above).

Memory Support

The X6DH8-G/X6DHE-G has eight 184-pin DIMM slots that can support up to 16 GB of registered ECC DDR333 or up to 32 GB of registered ECC DDR226 SDRAM. The memory is an interleaved configuration, which requires modules of the same size and speed to be installed in pairs. You should not mix modules of different sizes and/or speeds.

Note: if ECC registered DDR333 (PC2700) memory modules are used, configurations of four double-banked DIMMs or six single-banked DIMMs are supported.

Figure 5-4. Side View of DIMM Installation into Slot

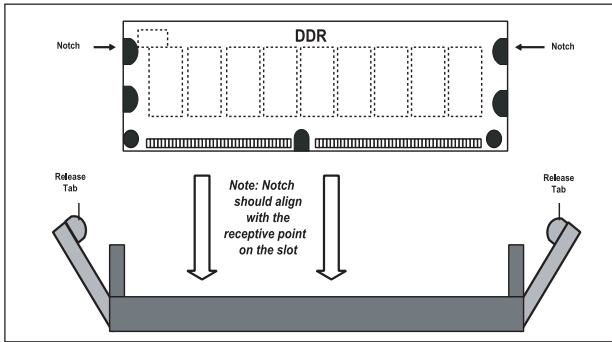

To Install: Insert module vertically and press down until it snaps into place. Pay attention to the bottom notches.

To Remove: Use your thumbs to gently push each release tab outward to free the module from the slot.

Figure 5-5. Top View of DIMM Slot

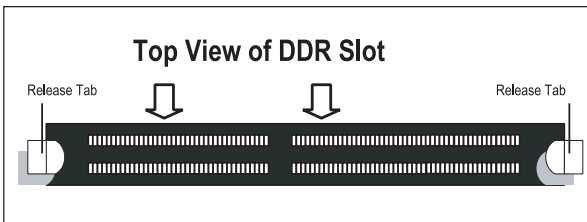

5-6 Adding PCI Cards

1. PCI slots:

The X6DH8-G/X6DHE-G has six PCI expansion slots, which includes two x8 PCI-Express slots, one 64-bit 133 MHz PCI-X slot, two 64-bit 100 MHz PCI-X slots and one 32-bit 33 MHz PCI slot. (One 100 MHz PCI slot supports Zero Channel RAID.)

The SC823i-550LP chassis accommodates up to seven full-length, low-profile PCI cards. PCI cards are installed directly to the serverboard (riser cards are not needed).

2. PCI card installation:

Before installing a PCI add-on card, make sure you install it into a slot that supports the speed of the card (see step 1, above). Begin by removing the screw from the I/O backpanel shield that corresponds to the slot you wish to populate. Insert the PCI card into the correct slot on the serverboard, pushing down with your thumbs evenly on both sides of the card. Finish by securing the card to the chassis with the same screw you removed from the I/O shield. Follow this procedure when adding a card to other slots.

5-7 Serverboard Details

Figure 5-6. SUPER X6DH8-G/X6DHE-G Layout*
(not drawn to scale)

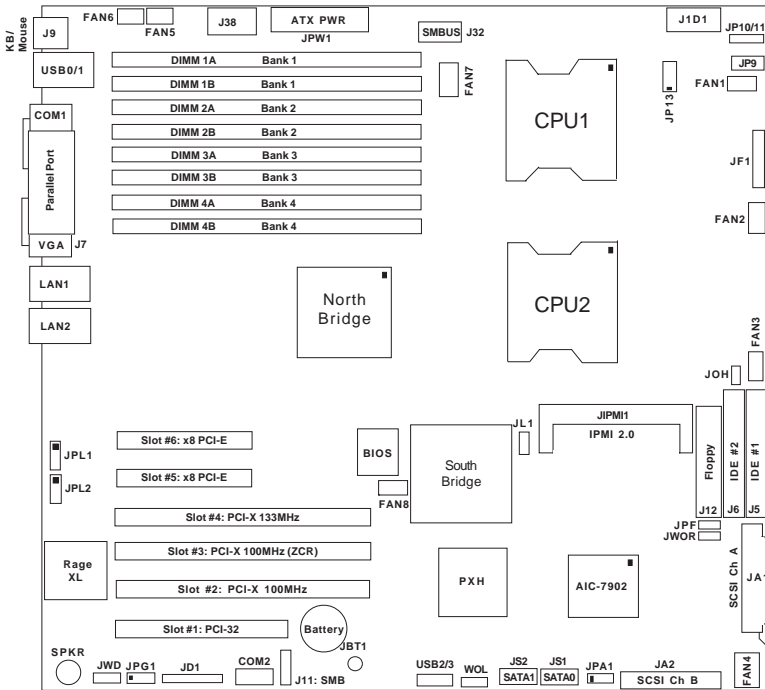

***Notes:**

Jumpers not noted are for test purposes only.

"■" indicates the location of Pin 1.

SCSI connectors and jumpers apply to the X6DH8-G only.

X6DH8-G/X6DHE-G Quick Reference

<u>Jumper</u>	<u>Description</u>	<u>Default Setting</u>
JBT1	CMOS Clear	See Section 5-9
JP10*	3rd PW Supply Fail Alarm Enable	Open (Disabled)
JP11	Alarm Reset	Open (Disabled)
JPA1*	SCSI Controller Enable	Pins 1-2 (Enabled)
JPF	Force PWR On	Open (Normal)
JPG1	Onboard VGA Enable	Pins 1-2 (Enabled)
JPL1	LAN1 Enable/Disable	Pins 1-2 (Enabled)
JPL2	LAN2 Enable/Disable	Pins 1-2 (Enabled)
JWD	Watch Dog	Pins 1-2 (Reset)

<u>Connector</u>	<u>Description</u>
COM1/COM2	COM1/COM2 Serial Port Connectors
DIMM#1A-DIMM#4B	DDR Memory Slots
FAN 1-8	Fans 1-8
J5/6	IDE1/2 Hard Disk Drive Connectors
J7	VGA Connector
J11	System Management Bus Header
J12	Floppy Disk Drive Connector
J32	SMBUS PS
J35	Parallel (Printer) Port
J38	+12V 4-pin Auxiliary Power (required connection)
J1D1	+12V 8-pin Processor Power (req. connection)
JA1*	SCSI Channel A Connector
JA2*	SCSI Channel B Connector
JD1	PWR LED (pins1-3)/Speaker Header (pins 4-7)
JF1	Front Control Panel Header
JIPM1	IPMI Connector
JL1	Chassis Intrusion Header
JOH	Overheat LED
JP9	Power Supply Fail Header
JPW1	Primary ATX PWR Connector
JS1/JS2	Intel SATA#0/1 Connectors
JWOR	Wake-on-Ring Header
LAN1/2	Gigabit Ethernet Ports
USB0/1	USB Ports
USB2/3	Front Panel USB2/3 Headers
WOL	Wake-on-LAN Header

*X6DH8-G (6042H-8R) only

5-8 Connector Definitions

ATX Power Connector

The X6DH8-G/X6DHE-G includes a 24-pin main power supply connector (JPW1) and a 4-pin Auxiliary PWR connector (J38). These power connectors meet the SSI EPS 12V specification. See the table on the right for pin definitions. For CPU power, please see the item below.

**ATX Power Supply 24-pin Connector
Pin Definitions (JPW1)**

Pin Number	Definition	Pin Number	Definition
13	+3.3V	1	+3.3V
14	-12V	2	+3.3V
15	COM	3	COM
16	PS_ON#	4	+5V
17	COM	5	COM
18	COM	6	+5V
19	COM	7	COM
20	Res(NC)	8	PWR_OK
21	+5V	9	5VSB
22	+5V	10	+12V
23	+5V	11	+12V
24	COM	12	+3.3V

Processor Power Connector

In addition to the Primary ATX power connector (above), the 12v 8-pin processor power connector at J1D1 must also be connected to your power supply. (If an 8-pin cable is not available, please use two 4-pin cables.) See the table on the right for pin definitions.

**+12V 4-pin Connector
(J38)**

	Pins #	Definition
Required	1 & 2	Ground
Connection	3 & 4	+12 V

	Pins	Definition
Required	1 thru 4	Ground
Connection	5 thru 8	+12v

**CPU 8-pin PWR
Connector (J1D1)**

NMI Button

The non-maskable interrupt button header is located on pins 19 and 20 of JF1. Refer to the table on the right for pin definitions.

**NMI Button Pin
Definitions (JF1)**

Pin Number	Definition
19	Control
20	Ground

Power LED

The Power LED connection is located on pins 15 and 16 of JF1. Refer to the table on the right for pin definitions.

**PWR_LED Pin Definitions
(JF1)**

Pin Number	Definition
15	Vcc
16	Control

HDD LED

The HDD LED (for IDE and SCSI Disk Drives) connection is located on pins 13 and 14 of JF1. Attach the hard drive LED cable to these pins to display disk activity. Refer to the table on the right for pin definitions.

HDD LED Pin Definitions (JF1)

Pin Number	Definition
13	Vcc
14	HD Active

NIC1/NIC2 LED

The NIC1 (Network Interface Controller) LED connection for LAN port1 is located on pins 11 and 12 of JF1 and the NIC2 LED connection for LAN2 is located on Pins 9 and 10 of JF1. Attach an LED cable to these pins to display network activity. Refer to the table on the right for pin definitions.

NIC1/NIC2 LED Pin Definitions (JF1)

Pin Number	Definition
9/11	Vcc
10/12	GND

OH/Fan Fail LED

Connect an LED to pins 7 and 8 of JF1 to provide warning of a processor overheating or a fan failure. The LED will blink/stay on as long as an overheat/fan fail condition exists. Refer to the table on the right for pin definitions.

OH/Fan Fail LED Pin Definitions (JF1)

Pin Number	Definition
7	Vcc
8	GND

Power Fail LED

The Power Fail LED connection is located on pins 5 and 6 of JF1. Refer to the table on the right for pin definitions.

Power Fail LED Pin Definitions (JF1)

Pin Number	Definition
5	Vcc
6	GND

Reset Button

The Reset Button connection is located on pins 3 and 4 of JF1. Attach it to the hardware reset switch on the computer case. Refer to the table on the right for pin definitions.

**Reset Pin
Definitions
(JF1)**

Pin Number	Definition
3	Reset
4	Ground

Power Button

The Power Button connection is located on pins 1 and 2 of JF1. Momentarily contacting both pins will power on/off the system. This button can also be configured to function as a suspend button (see the appropriate setting in BIOS). To turn off the power when set to suspend mode, depress the button for at least 4 seconds. Refer to the table on the right for pin definitions.

**Power Button
Connector
Pin Definitions
(JF1)**

Pin Number	Definition
1	PW_ON
2	Ground

Chassis Intrusion

A Chassis Intrusion header is located at JL1. Attach the appropriate cable to inform you of a chassis intrusion.

**Chassis Intrusion
Pin Definitions (JL1)**

Pin Number	Definition
1	Intrusion Input
2	Ground

Universal Serial Bus (USB0/1)

There are four USB 2.0 (Universal Serial Bus) ports/headers on the serverboard. Two of them are back panel USB ports (USB0/1) and the other two are front panel USB headers (USB2/3). See the tables on the right for pin definitions.

**USB Pin Definitions
(USB0/1)**

Pin#	Definition
1	Vcc
2	Data-
3	Data+
4	Ground

(FPUSB2/3)

Pin Number	Definition	Pin Number	Definition
1	Vcc	2	Vcc
3	Data-	4	Data-
5	Data+	6	Data+
7	Ground	8	Ground
9	Key	10	NA

Fan Headers

There are eight fan headers (FAN1-FAN8) on the serverboard. See the table on the right for pin definitions.

Notes: 1) These are 4-pin fan headers. Pins 1-3 are backward compatible with traditional 3-pin fans. 2) Fan speed is controlled by Thermal Management via BIOS (refer to "Hardware Monitoring" in the Advanced BIOS Setting.)

Fan Header Pin Definitions

Pin #	Definition
1	Ground (black)
2	+12V (red)
3	Tachometer
4	PWR_Control

Caution: These fan headers use DC power.

Serial Ports

The COM1 serial port is located under the parallel port (see Figure 5-3) and the COM2 header is located by the PCI slot. See the tables on the right for pin definitions.

**Serial Port Pin Definitions
(COM1)**

Pin Number	Definition	Pin Number	Definition
1	DCD	6	DSR
2	RXD	7	RTS
3	TXD	8	CTS
4	DTR	9	RI
5	GND		

**Serial Port Pin Definitions
(COM2)**

Pin Number	Definition	Pin Number	Definition
1	DCD	6	DSR
2	RXD	7	RTS
3	TXD	8	CTS
4	DTR	9	RI
5	GND	10	NC

ATX PS/2 Keyboard and PS/2 Mouse Ports

The ATX PS/2 keyboard and PS/2 mouse are located on J9. See the table at right for pin definitions. (See Figure 5-3 for the locations of each.)

**PS/2 Keyboard and Mouse Port Pin Definitions
(J9)**

Pin Number	Definition
1	Data
2	NC
3	Ground
4	VCC
5	Clock
6	NC

LAN1/2 (Ethernet Ports)

Two Gigabit Ethernet ports (designated LAN1 and LAN2) are located on the I/O backplane. These ports accept RJ45 type cables.



Power LED/Speaker/NMI

On the JDI header, pins 1-3 are for a power LED and pins 4-7 are for the speaker. See the table on the right for speaker pin definitions.

Speaker Connector Pin Definitions (JD1)

Pin Number	Function	Definition
4	+	Power
5	Key	No connection
6		Key
7		Speaker data

Note: The speaker connector pins are for use with an external speaker. If you wish to use the onboard speaker, you should close pins 6-7 with a jumper.

Wake-On-Ring

The Wake-On-Ring header is designated JWOR. This function allows your computer to receive and "wake-up" by an incoming call to the modem when in suspend state. See the table on the right for pin definitions. You must have a Wake-On-Ring card and cable to use this feature.

Wake-on-Ring Pin Definitions (JWOR)

Pin Number	Definition
1	Ground
2	Wake-up

Wake-On-LAN

The Wake-On-LAN header is located at WOL on the serverboard. See the table on the right for pin definitions. You must enable the LAN Wake-Up setting in BIOS to use this function. (You must also have a LAN card with a Wake-On-LAN connector and cable to use this feature.)

Wake-On-LAN Pin Definitions (WOL)

Pin Number	Definition
1	+5V Standby
2	Ground
3	Wake-up

Power Fail Header

Connect a cable from your power supply to the Power Fail header (JP9) to provide warning of power supply failure. This warning signal is passed through the PWR_LED pin to indicate of a power failure on the chassis. See the table on the right for pin definitions.

Note: this feature is available with the 6024H-8R only.

**Power Fail
Pin Definitions (JP9)**

Pin Number	Definition
1	P/S 1 Fail Signal
2	P/S 2 Fail Signal
3	P/S 3 Fail Signal
4	Reset (from MB)

Note: This feature is only available when using redundant Supermicro power supplies.

SMB

A System Management Bus header is located at J11. Connect the appropriate cable here to utilize SMB on your system. SMB is used to monitor the status of power supply, the fans and the system temperature. Power connection (below) is also required.

**SMB Header
Pin Definitions (J11)**

Pin Number	Definition
1	Data
2	Ground
3	Clock
4	No Connection

SMB Power (I² C) Connector

Connect the SMB power connector to J32 (located near DIMM slot #1A) to utilize SMB.

**SMB PWR
Pin Definitions (J24)**

Pin #	Definition
1	Clock
2	Data
3	N/A
4	N/A
5	N/A

Overheat LED (JOH)

Connect an LED to the JOH header to provide warning of chassis overheating. See the table on the right for pin definitions.

**Overheat LED
Pin Definitions (JOH)**

Pin Number	Definition
1	+5V
2	OH Active

5-9 Jumper Settings

Explanation of Jumpers

To modify the operation of the serverboard, jumpers can be used to choose between optional settings. Jumpers create shorts between two pins to change the function of the connector. Pin 1 is identified with a square solder pad on the printed circuit board. See the serverboard layout pages for jumper locations.

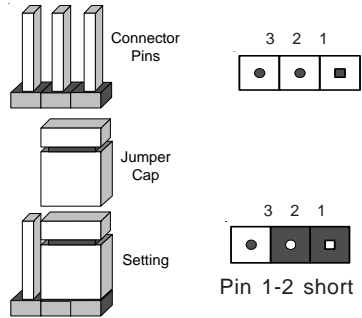

Note: On two pin jumpers, "Closed" means the jumper is on and "Open" means the jumper is off the pins.

CMOS Clear

JBT1 is used to clear CMOS (which will also clear any passwords). Instead of pins, this jumper consists of contact pads to prevent accidentally clearing the contents of CMOS.

To clear CMOS,

- 1) First unplug the power cord(s)
- 2) With the power disconnected, short the CMOS pads with a metal object such as a small screwdriver
- 3) Remove the screwdriver (or shorting device)
- 4) Reconnect the power cord(s) and power on the system.

Note: Do not use the PW_ON connector to clear CMOS.

LAN1 Enable/Disable

Change the setting of jumper JPL1 to enable or disable the onboard LAN port #1 on the serverboard. See the table on the right for jumper settings. The default setting is enabled

LAN1 Enable/Disable Jumper Settings (JPL1)

Jumper Position	Definition
Pins 1-2	Enabled
Pins 2-3	Disabled

LAN2 Enable/Disable

Change the setting of jumper JPL2 to enable or disable the onboard LAN port #2 on the serverboard. See the table on the right for jumper settings. The default setting is enabled

LAN2 Enable/Disable Jumper Settings (JPL2)

Jumper Position	Definition
Pins 1-2	Enabled
Pins 2-3	Disabled

SCSI Controller Enable/Disable (X6DH8-G only)

Jumper JPA1 allows you to enable or disable the SCSI headers. The default setting is pins 1-2 to enable all four headers. See the table on the right for jumper settings.

SCSI Enable/Disable Jumper Settings (JPA1)

Jumper Position	Definition
Pins 1-2	Enabled
Pins 2-3	Disabled

Watch Dog Enable/Disable

JWD enables the Watch Dog function. Watch Dog is a system monitor that can reboot the system when a software application is "hung up". Pins 1-2 will cause WD to reset the system if an application is hung up. Pins 2-3 will generate a non-maskable interrupt signal for the application that is hung up. See the table on the right for jumper settings. Watch Dog can also be enabled via BIOS.

Note: When enabled, the user needs to write his own application software in order to disable the Watch Dog Timer.

**Watch Dog
Jumper Settings (JWD)**

Jumper Position	Definition
Pins 1-2	WD to Reset
Pins 2-3	WD to NMI
Open	Disabled

Power Force On Enable/Disable

Jumper JPF allows you to enable or disable the Power Force On function. If enabled, the power will always stay on automatically. If this function disabled, the user needs to press the power button to power on the system.

**Force Power On
(JPF)**

Jumper Position	Definition
Open	Normal
Closed	Force On

VGA Enable/Disable

JPG1 enables or disables the VGA port on the serverboard. See the table on the right for jumper settings. The default setting is enabled.

**VGA
Enable/Disable
Jumper Settings
(JPG1)**

Jumper Position	Definition
Pins 1-2	Enabled
Pins 2-3	Disabled

3rd Power Supply Alarm Enable/Disable

The system can notify you in the event of a power supply failure. This feature assumes that three power supply units are installed in the chassis with one acting as a backup. If you only have one or two power supply units installed, you should disable this (the default setting) with JP10 to prevent false alarms. See the table on right for pin definitions.

Note: this setting should be disabled on the 6024H-i, which has a single power supply.

Power Supply Alarm Enable/Disable Jumper Settings (JP10)

Jumper Position	Definition
Open	Disabled
Closed	Enabled

Alarm Reset

The system will notify you in the event of a power supply failure. This feature assumes that Supermicro redundant power supply units are installed in the chassis. If you only have a single power supply installed, you should disable this (the default setting) with (JP11) to prevent false alarms. See the table on the right for jumper settings.

Note: this setting should be disabled on the 6024H-i, which has a single power supply.

Alarm Reset Jumper Settings (JP11)

Jumper Position	Definition
Open	Enabled
Closed	Disabled

5-10 Onboard Indicators

LAN1/LAN2 LEDs

Each of the Ethernet ports (located beside the VGA port) have two LEDs. The yellow (left) LED indicates activity while the other LED may be green, orange or off to indicate the speed of the connection. See the table on the right for the functions associated with this second LED.

1 Gb LAN Right LED Indicator

LED Color	Definition
Off	No Connection
Green	100 MHz
Orange	1 GHz

5-11 Parallel Port, Floppy/Hard Disk Drive and SCSI Connections

Note the following when connecting the floppy and hard disk drive cables:

- The floppy disk drive cable has seven twisted wires.
- A red mark on a wire typically designates the location of pin 1.
- A single floppy disk drive ribbon cable has 34 wires and two connectors to provide for two floppy disk drives. The connector with twisted wires always connects to drive A, and the connector that does not have twisted wires always connects to drive B.

Parallel (Printer) Port Connector

The parallel (printer) port is located on J35. See the table on the right for pin definitions.

Parallel (Printer) Port Pin Definitions (J35)

Pin Number	Function	Pin Number	Function
1	Strobe-	2	Auto Feed-
3	Data Bit 0	4	Error-
5	Data Bit 1	6	Init-
7	Data Bit 2	8	SLCT IN-
9	Data Bit 3	10	GND
11	Data Bit 4	12	GND
13	Data Bit 5	14	GND
15	Data Bit 6	16	GND
17	Data Bit 7	18	GND
19	ACK	20	GND
21	BUSY	22	GND
23	PE	24	GND
25	SLCT	26	NC

Floppy Connector

The floppy connector is located on J12. See the table below for pin definitions.

Floppy Connector Pin Definitions (JP12)

Pin Number	Function	Pin Number	Function
1	GND	2	FDHDIN
3	GND	4	Reserved
5	Key	6	FDEDIN
7	GND	8	Index-
9	GND	10	Motor Enable
11	GND	12	Drive Select B-
13	GND	14	Drive Select A-
15	GND	16	Motor Enable
17	GND	18	DIR-
19	GND	20	STEP-
21	GND	22	Write Data-
23	GND	24	Write Gate-
25	GND	26	Track 00-
27	GND	28	Write Protect-
29	GND	30	Read Data-
31	GND	32	Side 1 Select-
33	GND	34	Diskette

IDE Connectors

There are no jumpers to configure the onboard IDE#1 and #2 connectors. See the table on the right for pin definitions.

**IDE Connector Pin Definitions
(J5, J6)**

Pin Number	Function	Pin Number	Function
1	Reset IDE	2	GND
3	Host Data 7	4	Host Data 8
5	Host Data 6	6	Host Data 9
7	Host Data 5	8	Host Data 10
9	Host Data 4	10	Host Data 11
11	Host Data 3	12	Host Data 12
13	Host Data 2	14	Host Data 13
15	Host Data 1	16	Host Data 14
17	Host Data 0	18	Host Data 15
19	GND	20	Key
21	DRQ3	22	GND
23	I/O Write-	24	GND
25	I/O Read-	26	GND
27	IOCHRDY	28	BALE
29	DACK3-	30	GND
31	IRQ14	32	IOCS16-
33	Addr 1	34	GND
35	Addr 0	36	Addr 2
37	Chip Select 0	38	Chip Select 1-
39	Activity	40	GND

Ultra320 SCSI Connectors (X6DH8-G only)

Refer to the table below for the pin definitions of the Ultra320 SCSI connectors located at JA1 and JA2.

Ultra320 SCSI Connectors (JA1, JA2)

Connector Contact Number	Signal Names	Connector Contact Number	Signal Names
1	+DB(12)	35	-DB(12)
2	+DB(13)	36	-DB(13)
3	+DB(14)	37	-DB(14)
4	+DB(15)	38	-DB(15)
5	+DB(P1)	39	-DB(P1)
6	+DB(0)	40	-DB(0)
7	+DB(1)	41	-DB(1)
8	+DB(2)	42	-DB(2)
9	+DB(3)	43	-DB(3)
10	+DB(4)	44	-DB(4)
11	+DB(5)	45	-DB(5)
12	+DB(6)	46	-DB(6)
13	+DB(7)	47	-DB(7)
14	+DB(P)	48	-DB(P)
15	GROUND	49	GROUND
16	DIFFSENS	50	GROUND
17	TERMPWR	51	TERMPWR
18	TERMPWR	52	TERMPWR
19	RESERVED	53	RESERVED
20	GROUND	54	GROUND
21	+ATN	55	-ATN
22	GROUND	56	GROUND
23	+BSY	57	-BSY
24	+ACK	58	-ACK
25	+RST	59	-RST
26	+MSG	60	-MSG
27	+SEL	61	-SEL
28	+C/D	62	-C/D
29	+REQ	63	-REQ
30	+I/O	64	-I/O
31	+DB(8)	65	-DB(8)
32	+DB(9)	66	-DB(9)
33	+DB(10)	67	-DB(10)
34	+DB(11)	68	-DB(11)

Notes

Chapter 6

Advanced Chassis Setup

This chapter covers the steps required to install components and perform maintenance on the SC823S-R500LP/SC823i-550LP chassis. For component installation, follow the steps in the order given to eliminate the most common problems encountered. If some steps are unnecessary, skip ahead to the step that follows.

Tools Required

The only tool you will need to install components and perform maintenance is a Philips screwdriver.

6-1 Static-Sensitive Devices

Electricstatic discharge (ESD) can damage electronic components. To prevent damage to any printed circuit boards (PCBs), it is important to handle them very carefully. The following measures are generally sufficient to protect your equipment from ESD damage.

Precautions

- Use a grounded wrist strap designed to prevent static discharge.
- Touch a grounded metal object before removing any board from its anti-static bag.
- Handle a board by its edges only; do not touch its components, peripheral chips, memory modules or gold contacts.
- When handling chips or modules, avoid touching their pins.
- Put the motherboard, add-on cards and peripherals back into their anti-static bags when not in use.
- For grounding purposes, make sure your computer chassis provides excellent conductivity between the power supply, the case, the mounting fasteners and the serverboard.

Unpacking

The serverboard is shipped in antistatic packaging to avoid static damage. When unpacking the board, make sure the person handling it is static protected.

Figure 6-1a. 6024H-8R: Front and Rear Chassis Views

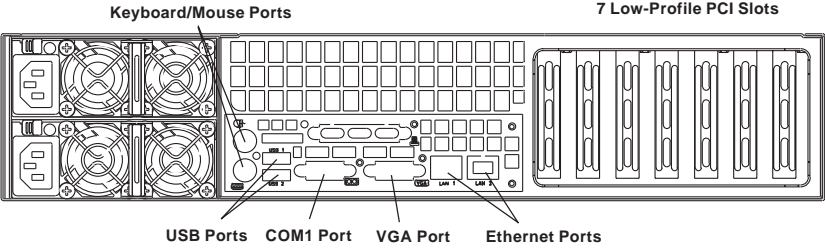
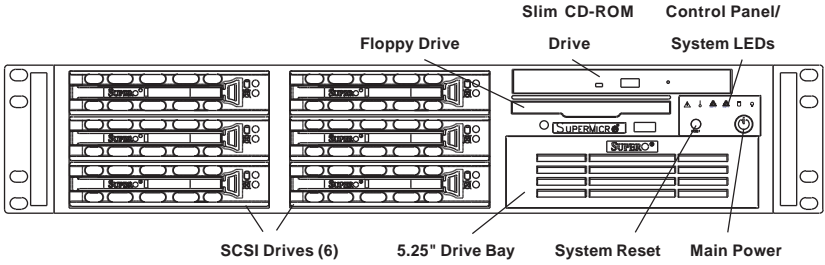
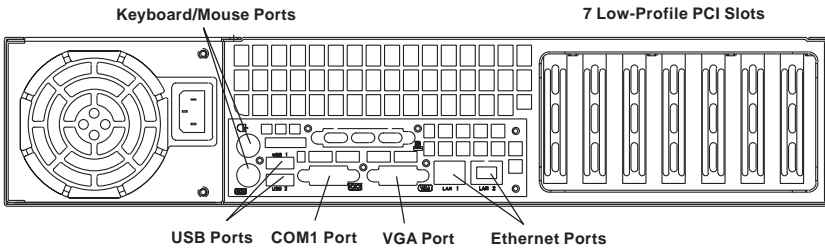
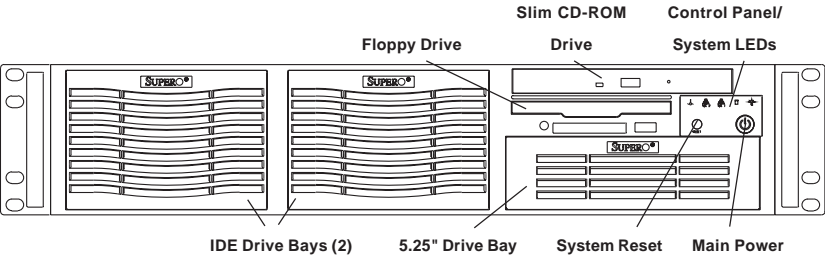

Figure 6-1b. 6024H-i: Front and Rear Chassis Views



6-2 Control Panel

The control panel (located on the front of the chassis) must be connected to the JF1 connector on the serverboard to provide you with system status indications. A ribbon cable has bundled these wires together to simplify the connection. Connect the cable from JF1 on the serverboard to JP4 on the Control Panel PCB (printed circuit board). Make sure the red wire plugs into pin 1 on both JF1 and JP4. Pull all excess cabling out of the airflow path. The LEDs inform you of system status. See Chapter 3 for details on the LEDs and the control panel buttons. Details on JF1 can be found in Chapter 5.

6-3 System Fans

Four 8-cm fans and an air shroud (which channels the air flow to the processors) provide all the cooling needed for the SuperServer 6024H-8R/6024H-i. It is very important that the chassis top cover is properly installed and making a good seal in order for the cooling air to circulate properly through the chassis and cool the components. See Figure 6-2.

System Fan Failure

The fans run at 6300 rpm. If a fan fails, the ambient air temperature in the chassis will rise and activate the overheat LED on the control panel. Replace any non-working fan immediately. The hot plug fan will start to function upon connection to its fan header on the X6DH8-G/X6DHE-G serverboard.

Replacing System Fans

1. Removing a fan

Remove the chassis cover. Press the tabs on the top of the fan housing and remove the fan and its housing. System power does not need to be shut down since the fans are all hot-pluggable.

2. Installing a new fan

Replace the failed fan with an identical 8-cm, 12 volt fan (available from Supermicro, p/n FAN-0070). Position the new fan at its proper place in the chassis by fitting the fan with its housing onto the fan mounts in the chassis. A "click" can be heard if the fan (in its housing) is properly installed. If the system power is on, the hot-plug feature will cause the fan to start immediately upon being connected to its header on the serverboard.

Figure 6-2. System Cooling Fans

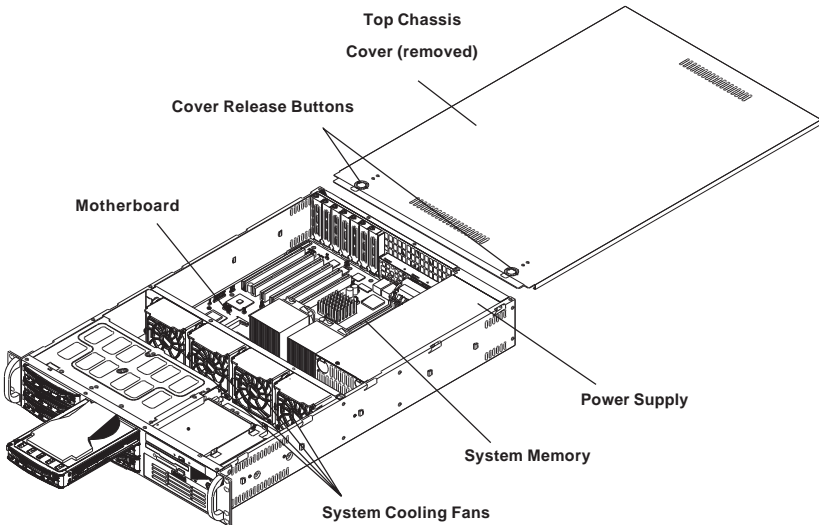

6-4 Drive Bay Installation/Removal

Accessing the Drive Bays

SCSI Drives (6024H-8R only): You do not need to access the inside of the chassis or remove power to replace or swap SCSI drives. Proceed to the next step for instructions. **Note:** You must use standard 1" high, 80-pin SCA SCSI drives in the SuperServer 6024H-8R.

IDE Drives (6024H-i only): You must power down the system and remove the top chassis cover to replace IDE drives. Proceed to the "IDE Drive Installation" section later in this chapter for instructions.

CD-ROM/Floppy Disk Drive: For installing/removing the CD-ROM or floppy disk drive, you will need to gain access to the inside of the server by removing the top cover of the chassis. Proceed to the "CD-ROM and Floppy Drive Installation" section later in this chapter for instructions.

5.25" Drive Bay: For installing/removing a component in the 5.25" drive bay, proceed to the "5.25" Drive Bay Installation" section later in this chapter for instructions.

SCSI Drive Installation (6024H-8R only)

1. Mounting a SCSI drive in a drive carrier

The SCSI drives are mounted in drive carriers to simplify their installation and removal from the chassis. These carriers also help promote proper airflow for the SCSI drive bays. For this reason, even empty carriers without SCSI drives installed must remain in the chassis. To add a new SCSI drive, install a drive into the carrier with the printed circuit board side toward the carrier so that the mounting holes align with those in the carrier (3a). Secure the drive to the carrier with three screws on each side (3b), as shown in Figure 6-3.

Figure 6-3. Mounting a SCSI Drive in a Carrier

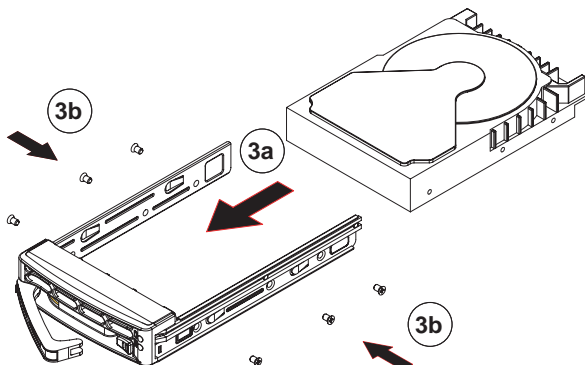

Use caution when working around the SCSI backplane. Do not touch the backplane with any metal objects and make sure no ribbon cables touch the backplane or obstruct the holes, which aid in proper airflow.



Important: Regardless of how many SCSI hard drives are installed, all SCSI drive carriers must remain in the drive bays for proper airflow.

2. Installing/removing hot-swap SCSI drives

The SCSI drive bays are located in the front of the chassis, making them easily accessible for installation and removal. The SCSI drives are hot-swap units, meaning that they can be installed and removed while the system is running. To remove a SCSI drive, first push the release button located beside the drive's LEDs, then swing the handle fully out and use it to pull the SCSI drive carrier straight out (see Figure 6-4).

Figure 6-4. Removing a SCSI Drive Carrier

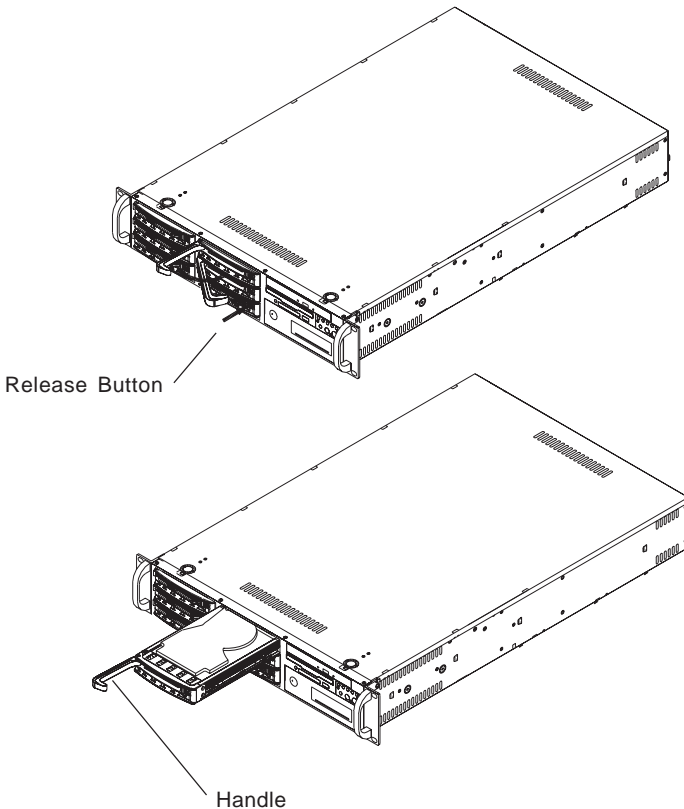

Important: All of the SCSI drive carriers must remain in the drive bay to maintain proper cooling airflow.

SCA Backplane

The SCSI drives plug into a SAF-TE compliant SCA backplane that provides power, SCSI ID and bus termination. A RAID controller can be used with the SCA backplane to provide data security. The operating system you use must have RAID support to enable the hot-swap capability of the SCSI drive. The SCA SCSI backplane is already preconfigured; there are no jumpers or switches.

Figure 6-5. SCSI SCA Backplane

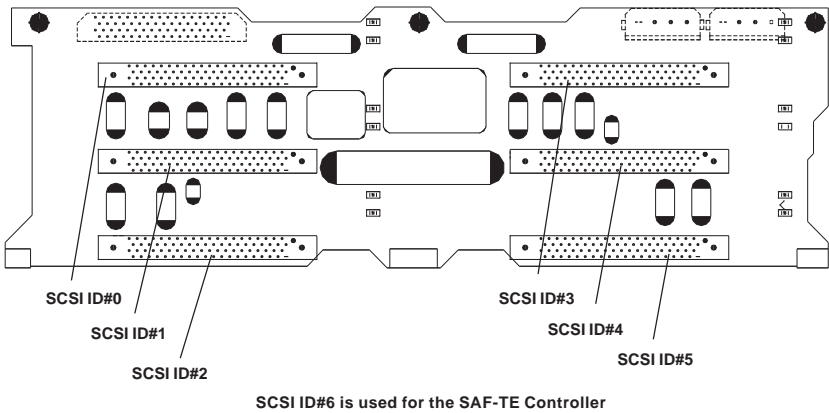

Removing the air shroud

Under most circumstances you will not need to remove the air shroud to perform any service on the system. However, if you wish to temporarily remove it (the air shroud should always be in place when the system is operating), please follow this procedure.

Begin by depressing the tabs at the front and rear of the shroud to unlock it, then lift it up and out of the chassis. To reinstall, simply position the air shroud in its proper place and push it in until you hear it click.

IDE Drive Installation (6024H-i only)

1. Hard drive support

Hard disk drives may be installed in the six internal fixed drive bays located at the front of the system. Hard drives in these bays are mounted in drive carriers to help promote proper airflow and shield against EMI. For this reason, even empty carriers without hard drives installed should remain in the chassis. You must power down the system before installing or removing any hard drive.

2. Mounting an IDE drive in a drive carrier

IDE hard drives are not hot-swappable, meaning system power must be turned off before installing and/or removing them. After power is removed from the system, remove the top chassis cover and unscrew the retention screw at the top center of the drive. Then push the back of the carrier so it exits the front of the chassis (see Figure 6-6).

When installing a hard disk drive, position it in the carrier with the printed circuit board side toward the carrier (facing down) and with the drive's mounting holes aligned with those in the carrier. Secure the drive to the carrier with four screws, as shown in Figure 6-6. Fully insert the carrier back into the chassis (the drive's data and power cables will connect upon insertion), then replace the cover and restore power to the system.

Installing a Component in the 5.25" Drive Bay

1. Mounting the component in the drive carrier

A component such as an additional IDE hard drive or SCSI drive that can fit into a standard IDE drive bay can be mounted in the 5.25" drive bay. The component should also be mounted in a drive carrier to simplify its installation and removal from the chassis. The carrier also helps promote proper airflow. For this reason, even an empty carrier without a component installed must remain in the chassis. To add a component such as those noted above, install a drive into the carrier with the printed circuit board side toward the carrier (facing down) so that the mounting holes align with those in the carrier. Secure the drive to the carrier with the four screws.

2. Installing/removing 5.25" drive bay component

A single 5.25" IDE drive bay is located in the front of the chassis, making it easily accessible for installation and removal. This component is not hot-swappable, meaning system power must be turned off before installing and/or removing them.

To remove the drive carrier, first power down the system and then remove the top cover of the chassis. Unscrew the retention screw at the top center of the drive, then push the drive carrier out from the back until you can grasp and pull it out through the front of the chassis. Attach the component to the carrier if installing. Then reverse the drive carrier removal procedure to install the drive, making sure you screw in the retention screw. Replace the top cover when finished.

Figure 6-6. Removing an IDE Drive Carrier

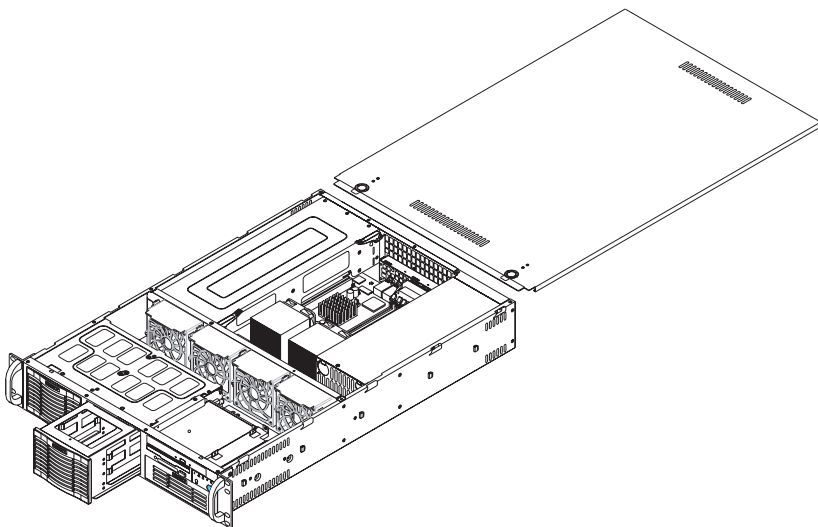

CD-ROM and Floppy Drive Installation

The top cover of the chassis must be opened to gain full access to the CD-ROM and floppy drive bays. The 6024H-8R/6024H-i accommodates only slim type CD-ROM drives. Side mounting brackets are typically needed to mount a slim CD-ROM drive in the 6024H-8R/6024H-i server.

First, release the retention screws that secure the server unit to the rack. Grasp the two handles on either side and pull the unit straight out until it locks (you will hear a "click"). Next, depress the two buttons on the top of the chassis to release the top cover and at the same time, push the cover away from you until it stops. You can then lift the top cover from the chassis to gain full access to the inside of the server. You must power down the system before installing or removing floppy or IDE components.

Drives mount on rails and should "click" into place to be correctly and fully installed in their bays.

- The floppy disk drive cable has seven twisted wires.
- A color mark on a cable typically designates the location of pin 1.
- A single floppy disk drive ribbon cable has 34 wires and two connectors to provide for two floppy disk drives. The connector with twisted wires always connects to drive A, and the connector that does not have twisted wires always connects to drive B.

6-5 Power Supply: 6024H-8R

The SuperServer 6024H-8R has a 500 watt redundant power supply consisting of two power modules. Each power supply module has an auto-switching capability, which enables it to automatically sense and operate at a 100V or 240V input voltage.

Power Supply Failure

If either of the two power supply modules fail, the other module will take the full load and allow the system to continue operation without interruption. The PWR Fail LED will illuminate and remain on until the failed unit has been replaced. Replacement units can be ordered directly from Supermicro (see contact information in the Preface). The power supply units have a hot-swap capability, meaning you can replace the failed unit without powering down the system.

Removing/Replacing the Power Supply

You do not need to shut down the system to replace a power supply unit. The redundant feature will keep the system up and running while you replace the failed hot-swap unit. Replace with the same model - SP502-2S (p/n PWS-0049), which can be ordered directly from Supermicro (see Contact Information in the Preface).

1. Removing the power supply

First unplug the power cord from the failed power supply unit. Then depress the locking tab on the power supply unit and pull the unit straight out with the rounded handle.

2. Installing a new power supply

Replace the failed hot-swap unit with another SP502-2S power supply unit (p/n PWS-0049). Simply push the new power supply unit into the power bay until you hear a click. Secure the locking tab on the unit and finish by plugging the AC power cord back into the unit.

6-6 Power Supply: 6024H-i

The SuperServer 6024H-i has a single 550 watt power supply. This power supply has an auto-switching capability, which enables it to automatically sense and operate at a 100V or 240V input voltage.

Power Supply Failure

If the power supply unit fails, the system will shut down and you will need to replace the power supply unit. Replace with the same model - SP552-2C (p/n PWS-0047), which can be ordered directly from Supermicro (see Contact Information in the Preface). As there is only one power supply unit in the 6024H-i, the server must be powered down before removing and/or replacing the power supply for whatever reason.

Removing/Replacing the Power Supply

1. Removing the power supply

First turn the power switch on the control panel off, then unplug the power cord from the system. Remove the chassis cover by pressing the two release buttons on the top of the chassis (near the front) and push the chassis top rearward about one inch. To remove the failed power unit, remove all screws that connect the power supply to the chassis (two at the rear, four at the side, one on the bottom and one at the front). The power supply can then be lifted straight up and out of the chassis.

2. Installing a new power supply

Replace the failed unit with another unit of the same input voltage, output voltage and wattage. It is highly recommended to replace it with exactly the same model power supply. Carefully insert the new unit into position in the chassis and secure it with the eight screws described in the paragraph above. Then reconnect the power cord, replace the chassis top cover and reposition the unit back into the rack. Finish by depressing the power button on the chassis front panel.

Chapter 7

BIOS

7-1 Introduction

This chapter describes the Phoenix BIOS™ Setup utility for the X6DH8-G2/X6DHE-G2. The Phoenix ROM BIOS is stored in a flash chip and can be easily upgraded using a floppy disk-based program. Due to periodic changes in the BIOS, some settings may have been added or deleted that might not yet be recorded in this manual. Please refer to the Manual Download area of the Supermicro web site (www.supermicro.com) for any such changes.

Starting the Setup Utility

To enter the BIOS Setup Utility, hit the <Delete> key while the system is booting-up. (In most cases, the <Delete> key is used to invoke the BIOS setup screen. There are a few cases when other keys are used, such as <F1>, <F2>, and so on.)

Each main BIOS menu option is described in this manual. The Main BIOS screen has two main frames. The left frame displays all the options that can be configured. "Grayed-out" options cannot be configured. The right frame displays the key legend. Above the key legend is an area reserved for a text message. When an option is selected in the left frame, it is highlighted in white. Often a text message will accompany it. (Note: BIOS has default text messages built in. Supermicro retains the option to include, omit, or change any of these text messages.) Options printed in **Bold** are the default settings.

The BIOS setup/utility uses a key-based navigation system called hot keys. Most of these hot keys (<F1>, <F10>, <Enter>, <ESC>, <Arrow> keys, etc.) can be used at any time during the setup navigation process.

Note: fan speed is controlled by the "Auto Fan Control" setting in BIOS. The recommended setting for the 6024H-82R/6024H-i2 is "3-wire Mode". If you load the BIOS default settings this setting may change. Therefore, if you do load BIOS defaults, you should reenter BIOS setup and change this setting back to **"3-wire Mode"**, then save and exit (see page 7-18).

7-2 Running Setup

Default settings are in bold text unless otherwise noted.

The BIOS setup options described in this section are selected by choosing the appropriate text from the main BIOS Setup screen. All displayed text is described in this section, although the screen display is often all you need to understand how to set the options (see on next page).

When you first power on the computer, the Phoenix BIOS™ is immediately activated.

While the BIOS is in control, the Setup program can be activated in one of two ways:

1. By pressing <Delete> immediately after turning the system on, or
2. When the message shown below appears briefly at the bottom of the screen during the POST (Power On Self-Test), press the <Delete> key to activate the main Setup menu:

Press the <Delete> key to enter Setup

Note: Please load "System Setup Default" when using the system for the first time.

7-3 Main BIOS Setup

All main Setup options are described in this section. The main BIOS Setup screen is displayed below.

Use the Up/Down arrow keys to move among the different settings in each menu. Use the Left/Right arrow keys to change the options for each setting.

Press the <Esc> key to exit the CMOS Setup Menu. The next section describes in detail how to navigate through the menus.

Items that use submenus are indicated with the ► icon. With the item highlighted, press the <Enter> key to access the submenu.

Main BIOS Setup Menu

PhoenixBIOS Setup - Copyright 1985-2001 Phoenix Technologies Ltd.		
Main Advanced Security Boot Exit		
System Time:	[11:42:57]	Item Specific Help <Tab>, <Shift-Tab>, or <Enter> selects field.
System Date:	[03-17-2004]	
BIOS Date		
Legacy Diskette A:	[1.44/1.25 MB 3½"]	
Parallel ATA:	[Both]	
Serial ATA:	[Enabled]	
SATA RAID Enable	[Disabled]	
Native Mode Operation:	[Auto]	
▶ IDE Channel 0 Master		
▶ IDE Channel 0 Slave		
▶ IDE Channel 1 Master		
▶ IDE Channel 1 Slave		
▶ IDE Channel 2 Master		
▶ IDE Channel 3 Master		
System Memory:	[XXXX KB]	
Extended Memory:	[XXXX KB]	
F1 Help ↑↓ Select Item -/+ Change Values F9 Setup Defaults		
Esc Exit ↔ Select Menu Enter Select ▶ Sub-Menu F10 Previous Values		

Main Setup Features

System Time

To set the system date and time, key in the correct information in the appropriate fields. Then press the <Enter> key to save the data.

System Date

Using the arrow keys, highlight the month, day and year fields and enter the correct data. Press the <Enter> key to save the data.

BIOS Date

This feature allows BIOS to automatically display the BIOS date.

Legacy Diskette A

This setting allows the user to set the type of floppy disk drive installed as diskette A. The options are Disabled, 360Kb 5.25 in, 1.2MB 5.25 in, 720Kb 3.5 in, **1.44/1.25MB**, 3.5 in and 2.88MB 3.5 in.

Parallel ATA

This setting allows the user to enable or disable the Parallel ATA function. The options are Disabled, Channel 0, Channel 1 and **Both**.

Serial ATA

This setting allows the user to enable or disable the Serial ATA function. The options are Disabled and **Enabled**.

Serial ATA RAID Enable

Select Enable to enable Serial ATA RAID Functions. (For a Windows OS environment, use the RAID driver if this feature is set to Enabled. If set to **Disabled**, use the Non-RAID driver.)

Native Mode Operation

Select the native mode for ATA. The options are Parallel ATA, Serial ATA, Both and **Auto**.

► IDE Channel 0 Master/Slave, IDE Channel 1 Master/Slave, IDE Channel 2 Master, IDE Channel 3 Master

These settings allow the user to set the parameters of IDE Channel 0 Master/Slave, IDE Channel 1 Master/Slave, IDE Channel 2 Master, IDE Channel 3 Master slots. Hit <Enter> to activate the following sub-menu screen for detailed options of these items. Set the correct configurations accordingly. The items included in the sub-menu are:

PhoenixBIOS Setup - Copyright 1985-2001 Phoenix Technologies Ltd.	
Main	
Type: CHS Format Cylinders: Cylinders: Heads: [1] Heads: Sectors: Sectors: Maximum Capacity: Maximum Capacity: LBA Format Total Sectors: Maximum Capacity: Multi-Sector Transfers: [Disabled] LBA Mode Control: [Disabled] 32 Bit I/O: [Disabled] Transfer Mode: [Standard] Ultra DMA Mode: [Disabled]	Item Specific Help User = you enter parameters of hard-disk drive installed at this connection. Auto = autotypes hard-disk drive installed here. 1-39 = you select pre-determined type of hard-disk drive installed here. CD-ROM = a CD-ROM drive is installed here. ATAPI Removable = removable disk drive is installed here.
F1 Help ↑↓ Select Item ~/+ Change Values F9 Setup Defaults Esc Exit ↔ Select Menu Enter Select ▸ Sub-Menu F10 Previous Values	

Type

Selects the type of IDE hard drive. The options are **Auto**, (which allows BIOS to automatically determine the hard drive's capacity, number of heads, etc.), a number from 1-39 (to select a predetermined type of hard drive), CDROM and ATAPI Removable. The "User" option will allow the user to enter the parameters of the HDD installed at this connection. The option-"Auto" will allow BIOS to automatically configure the parameters of the HDD installed at the connection. Choose the option 1-39 to select a predetermined HDD type. Select CDROM if a CDROM drive is installed. Select ATAPI if a removable disk drive is installed.

CHS Format

The following items will be displayed:

Type: This item displays the type of CPU.

Cylinders: This item indicates the status of cylinders.

Headers: This item indicates the number of headers.

Sectors: This item displays the number of sectors.

Maximum Capacity: This item displays the maximum storage capacity of the system.

LBA Format

The following items will be displayed:

Total Sectors: This item displays the number of total sectors available in the LBA Format.

Maximum Capacity: This item displays the maximum capacity in the LBA Format.

Multi-Sector Transfer

This item allows the user to specify the number of sectors per block to be used in multi-sector transfer. The options are Disabled, 4 Sectors, 8 Sectors and **16 Sectors**.

LBA Mode Control

This item determines whether Phoenix BIOS will access the IDE Channel 0 Master Device via the LBA mode. The options are **Enabled** and Disabled.

32 Bit I/O

This option allows the user to enable or disable the function of 32-bit data transfer. The options are Enabled and **Disabled**.

Transfer Mode

Selects the transfer mode. The options are **Standard**, Fast PIO1, Fast PIO2, Fast PIO3, Fast PIO4, FPIO3/DMA1 and FPIO4/DMA2.

Ultra DMA Mode

Selects the Ultra DMA Mode. The options are **Disabled**, Mode 0, Mode 1, Mode 2, Mode 3, Mode 4 and Mode 5.

System Memory

This display informs you how much system memory is recognized as being present in the system.

Extended Memory

This display informs you how much extended memory is recognized as being present in the system.

7-4 Advanced Setup

Choose Advanced from the Phoenix BIOS Setup Utility main menu with the arrow keys. You should see the following display. The items with a triangle beside them have sub menus that can be accessed by highlighting the item and pressing <Enter>. Options for PIR settings are displayed by highlighting the setting option using the arrow keys and pressing <Enter>.

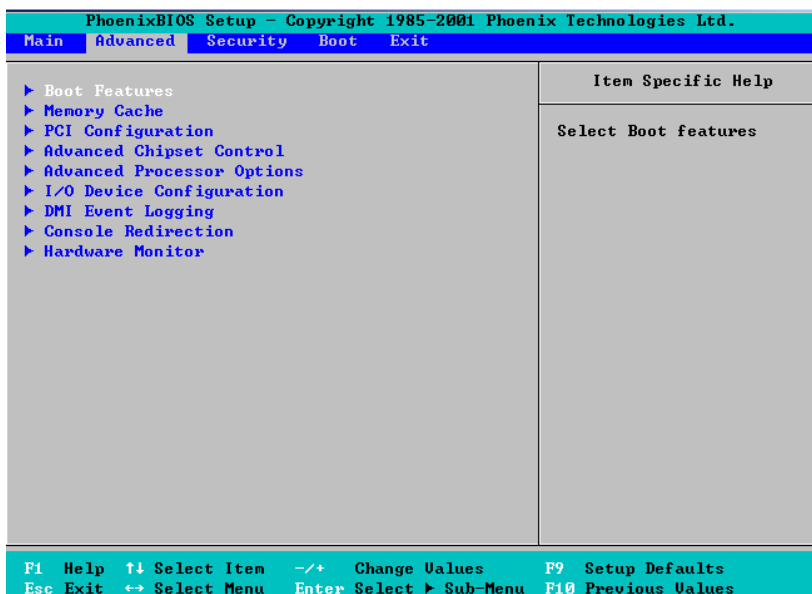

▶ Boot Features

Access the submenu to make changes to the following settings.

Quick Boot Mode

If enabled, this feature will speed up the POST (Power On Self Test) routine by skipping certain tests after the computer is turned on. The settings are **Enabled** and Disabled. If Disabled, the POST routine will run at normal speed.

Quiet Boot

This setting allows you to Enable or **Disable** the diagnostic screen during boot-up.

ACPI Mode

Use the setting to determine if you want to employ ACPI (Advanced Configuration and Power Interface) power management on your system. The options are **Yes** and **No**.

Power Loss Control

This setting allows you to choose how the system will react when power returns after an unexpected loss of power. The options are **Stay Off**, **Power On** and **Last State**.

Watch Dog

If enabled, this option will automatically reset the system if the system is not active for more than 5 minutes. The options are **Enabled** and **Disabled**.

Summary Screen

This setting allows you to **Enable** or **Disable** the summary screen which displays the system configuration during bootup.

► Memory Cache

Cache System BIOS Area

This setting allows you to designate a reserve area in the system memory to be used as a System BIOS buffer to allow the BIOS write (cache) its data into this reserved memory area. Select "**Write Protect**" to enable this function, and this area will be reserved for BIOS ROM access only. Select "Uncached" to disable this function and make this area available for other devices.

Cache Video BIOS Area

This setting allows you to designate a reserve area in the system memory to be used as a Video BIOS buffer to allow the BIOS write (cache) its data into this reserved memory area. Select "**Write Protect**" to enable the function and this area will be reserved for Video BIOS ROM access only. Select "Uncached" to disable this function and make this area available for other devices.

Cache Base 0-512K

If enabled, this feature will allow the data stored in the base memory area: block 0-512K to be cached (written) into a buffer, a storage area in the Static DRAM (SDROM) or to be written into the L1/ L2/ L3 cache

inside the CPU to speed up CPU operations. Select "Uncached" to disable this function. Select "Write Through" to allow data to be cached into the buffer and written into the system memory at the same time. Select "Write Protect" to prevent data from being written into the base memory area of Block 0-512K. Select "Write Back" to allow CPU to write data back directly from the buffer without writing data to the System Memory for fast CPU data processing and operation. The options are "Uncached", "Write Through", "Write Protect" and **"Write Back"**.

Cache Base 512K-640K

If enabled, this feature will allow the data stored in the memory area: 512K-640K to be cached (written) into a buffer, a storage area in the Static DRAM (SDROM) or written into the L1/ L2/ L3 cache inside the CPU to speed up CPU operations. Select "Uncached" to disable this function. Select "Write Through" to allow data to be cached into the buffer and written into the system memory at the same time. Select "Write Protect" to prevent data from being written into the base memory area of Block 0-512K. Select "Write Back" to allow CPU to write data back directly from the buffer without writing data to the System Memory for fast CPU data processing and operation. The options are "Uncached", "Write Through", "Write Protect" and **"Write Back"**.

Cache Extended Memory

If enabled, this feature will allow the data stored in the extended memory area to be cached (written) into a buffer, a storage area in the Static DRAM (SDROM) or written into the L1/ L2/ L3 cache inside the CPU to speed up CPU operations. Select "Uncached" to disable this function. Select "Write Through" to allow data to be cached into the buffer and written into the system memory at the same time. Select "Write Protect" to prevent data from being written into the base memory area of Block 0-512K. Select "Write Back" to allow CPU to write data back directly from the buffer without writing data to the System Memory for fast CPU data processing and operation. The options are "Uncached", "Write Through", "Write Protect" and **"Write Back"**.

► PCI Configuration

Access the submenu to make changes to the following settings for PCI devices.

Onboard GLAN (Gigabit- LAN) OPROM Configure

Enabling this option provides the capability to boot from the GLAN. The options are Disabled and **Enabled**.

Onboard SCSI OPROM Configure

Enabling this option provides the capability to boot from a SCSI HDD. The options are Disabled and **Enabled**.

Reset Configuration Data

If set to Yes, this setting clears the Extended System Configuration Data- (ESCD) area. The options are Yes and **No**.

Frequency for Slot#2-Slot#3/SCSI

This option allows the user to change the bus frequency for the devices installed in the slot indicated. The options are **Auto**, PCI 33 MHz, PCI 66 MHz, PCI-X 66 MHz, PCI-X 100 MHz and PCI-X 133 MHz.

Frequency for Slot#4

This option allows the user to change the bus frequency of the devices installed in the slot indicated. The options are **Auto**, PCI 33 MHz, PCI 66 MHz, PCI-X 66 MHz, PCI-X 100 MHz and PCI-X 133 MHz.

► PCI Devices, Slot #1 - Slot#6

Access the submenu for each of the settings above to make changes to the following:

Option ROM Scan

When enabled, this setting will initialize the device expansion ROM. The options are **Enabled** and Disabled.

Enable Master

This setting allows you to enable the selected device as the PCI bus master. The options are Enabled and **Disabled**.

Latency Timer

This setting allows you to set the clock rate for Bus Master. A high-priority, high-throughput device may benefit from a greater clock rate. The options are **Default**, 0020h, 0040h, 0060h, 0080h, 00A0h, 00C0h, and 00E0h. For Unix, Novell and other Operating Systems, please select the option "Other". If a drive fails after the installation of a new software, you might want to change this setting and try again. Different OSs requires different Bus Master clock rates.

Large Disk Access Mode

This setting determines how large hard drives are to be accessed. The options are **DOS** and Other (for Unix, Novelle NetWare and other operating systems).

►Advanced Chipset Control

Access the submenu to make changes to the following settings.

Force Compliance Mode

This feature allows you to enable the PCI-Express Compliance Mode. The options are **Disabled** and Enabled.

PCI-E Express Jitter Tolerance

This feature allows the user to set the PCI-E Jitter Tolerance Level. The options are **4** to 12.

PCI-E Port A Device 2/PCI-E Port B Device 4

If enabled, the feature allows you to set the device selected to be compliant with the PCI-Express Compliance 1.0 Mode. The options are Disabled, Enabled and **Auto**.

Memory RAS Feature Control

Select this option in order to enable the special feature of DIMM sparing or memory mirroring. The options are Mirroring, Sparing and **Standard**.

Clock Spectrum Feature

If "Enabled", BIOS will monitor the level of Electromagnetic Interference caused by the components and will attempt to decrease the interference whenever needed. The options are Enabled and **Disabled**.

DRAM Data Integrity Mode

If enabled, this feature allows the data stored in the DRAMA memory to be integrated for faster data processing. The options are 72-bit ECC, 144-bit ECC, **Auto** and Disabled.

ECC Error Type

This setting lets you select which type of interrupt is to be activated as a result of an ECC error. The options are **None**, NMI (Non-Maskable Interrupt), SMI (System Management Interrupt) and SCI (System Control Interrupt.)

SERR Signal Condition

This setting specifies the ECC error conditions that an SERR# is to be asserted. The options are None, **Single Bit**, Multiple Bit and Both.

USB Device 29, Function 0 & 1

This setting allows you to **Enable** or Disable all functions for the USB devices specified.

Legacy USB Support

This setting allows you to enable support for Legacy USB devices. The settings are **Enabled** and Disabled.

► Advanced Processor Options

Access the submenu to make changes to the following settings.

CPU Speed

This is a display that indicates the speed of the installed processor.

Hyper-threading

This setting allows you to **Enable** or **Disable** the hyper-threading function. Hyper-threading results in increased CPU performance. (Applicable for the XP systems.)

Set Maximum Extended CPUID=3

If enabled, this feature allows you to set the value of Maximum CPUID Extended function to 3. The options are **Enabled** and **Disabled**.

► I/O Device Configuration

Access the submenu to make changes to the following settings.

Serial Port A

This setting allows you to assign control of serial port A. The options are **Enabled** (user defined), **Disabled** and **Auto** (BIOS or OS controlled).

Base I/O Address

Select the base I/O address for serial port A. The options are **3F8**, **2F8**, **3E8** and **2E8**.

Interrupt

Select the IRQ (interrupt request) for serial port A. The options are **IRQ3** and **IRQ4**.

Serial Port B

This setting allows you to assign control of serial port B. The options are **Enabled** (user defined), Disabled, Auto (BIOS controlled) and OS Controlled.

Mode

Specify the type of device that will be connected to serial port B. The options are **Normal** and IR (for an infrared device).

Base I/O Address

Select the base I/O address for serial port B. The options are 3F8, 2F8, 3E8 and 2E8.

Interrupt

Select the IRQ (interrupt request) for serial port B. The options are **IRQ3** and IRQ4.

Parallel Port

This setting allows you to assign control of the parallel port. The options are **Enabled** (user defined), Disabled and Auto (BIOS or OS controlled).

Base I/O Address

Select the base I/O address for the parallel port. The options are **378**, 278 and 3BC.

Interrupt

Select the IRQ (interrupt request) for the parallel port. The options are IRQ5 and **IRQ7**.

Mode

This feature allows you to specify the parallel port mode. The options are Output only, Bi-Directional, EPP and **ECP**.

DMA Channel

This item allows you to specify the DMA channel for the parallel port. The options are DMA1 and **DMA3**.

Floppy Disk Controller

This setting allows you to assign control of the floppy disk controller. The options are **Enabled** (user defined), Disabled and Auto (BIOS and OS controlled).

Base I/O Address

Select the base I/O address for the parallel port. The options are **Primary** and Secondary.

►DMI Event Logging

Access the submenu to make changes to the following settings.

Event Log Validity

This is a display to inform you of the event log validity. It is not a setting.

Event Log Capacity

This is a display to inform you of the event log capacity. It is not a setting.

View DMI Event Log

Highlight this item and press <Enter> to view the contents of the event log.

Event Logging

This setting allows you to **Enable** or Disable event logging.

ECC Event Logging

This setting allows you to **Enable** or Disable ECC event logging.

Mark DMI Events as Read

Highlight this item and press <Enter> to mark the DMI events as read.

Clear All DMI Event Logs

Select Yes and press <Enter> to clear all DMI event logs. The options are Yes and **No**.

► Console Redirection

Access the submenu to make changes to the following settings.

COM Port Address

This item allows you to specify to redirect the console to Onboard COM A or Onboard COM B. This setting can also be **Disabled**.

BAUD Rate

This item allows you to select the BAUD rate for console redirection. The options are 300, 1200, 2400, 9600, **19.2K**, 38.4K, 57.6K and 115.2K.

Console Type

This item allows you to choose from the available options to select the console type for console redirection. The options are VT100, VT100,8bit, PC-ANSI, 7bit, **PC ANSI**, VT100+ and VT-UTF8.

Flow Control

This item allows you to choose from the available options to select the flow control for console redirection. The options are None, XON/XOFF and **CTS/RTS**.

Console Connection

This item allows you to choose select the console connection. The options are **Direct** and Via Modem.

Continue CR after POST

Choose whether to continue with console redirection after the POST routine. The options are On and **Off**.

► Hardware Monitor Logic

CPU Temperature Threshold

This option allows the user to set a CPU temperature threshold that will activate the alarm system when reached. The options are 70°C, **75°C**, 80°C and 85°C.

Highlight this and hit <Enter> to see monitor data for the following items:

CPU1 Temperature: This item displays CPU1 Temperature.

CPU2 Temperature: This item displays CPU2 Temperature.

System Temperature: This item displays the System Temperature.

Auto Fan Control

Select **3-Wire Mode** to allow the speed of onboard CPU and Chassis Fans to be controlled by DC Voltage. Select 4-Wire Mode to allow the onboard Fan Speed to be controlled by PWM (Pulse Width Modulation).

CHS Fan 1 - CHS FAN8: If the Auto Fan Control feature is enabled, BIOS will automatically display the status of the fans indicated in this item.

Vcore A/Vcore B: These items display the Voltage status of CPU A and CPU B.

P3V3: This item displays the +3.3V voltage status.

P5V: This item displays the +5V voltage status.

N12V: This item displays the -12V voltage status.

P12V: This item displays the +12V voltage status.

VDD: This item displays the VDD status.

P5Vsb: This item displays the +5V standby power voltage status.

P3P3Vsb: This item displays the +3.3V standby power voltage status.

7-5 Security

Choose Security from the Phoenix BIOS Setup Utility main menu with the arrow keys. You should see the following display. Security setting options are displayed by highlighting the setting using the arrow keys and pressing <Enter>.

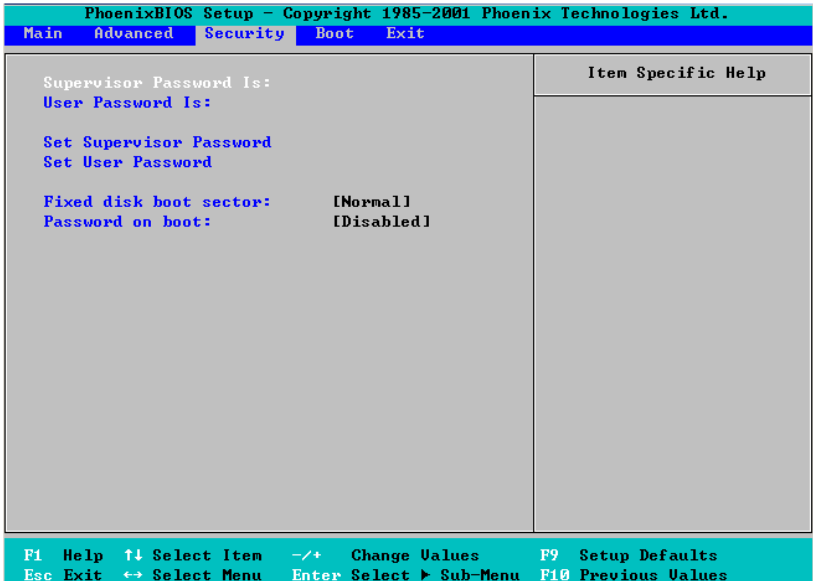

Supervisor Password Is:

This displays whether a supervisor password has been entered for the system. "Clear" means such a password has not been used and "Set" means a supervisor password has been entered for the system.

User Password Is:

This displays whether a user password has been entered for the system. "Clear" means such a password has not been used and "Set" means a user password has been entered for the system.

Set Supervisor Password

When the item "Set Supervisor Password" is highlighted, hit the <Enter> key. When prompted, type the Supervisor's password in the dialogue box to set or to change supervisor's password, which allows access to BIOS.

Set User Password

When the item "Set User Password" is highlighted, hit the <Enter> key. When prompted, type the user's password in the dialogue box to set or to change the user's password, which allows access to the system at boot-up.

Fixed Disk Boot Sector

This setting may offer some protection against viruses when set to Write Protect, which protects the boot sector on the hard drive from having data written to it. The other option is **Normal**.

Password on Boot

This setting allows you to require a password to be entered when the system boots up. The options are Enabled (password required) and **Disabled** (password not required).

7-6 Boot

Choose Boot from the Phoenix BIOS Setup Utility main menu with the arrow keys. You should see the following display. Highlighting a setting with a + or - will expand or collapse that entry. See details on how to change the order and specs of boot devices in the Item Specific Help window.

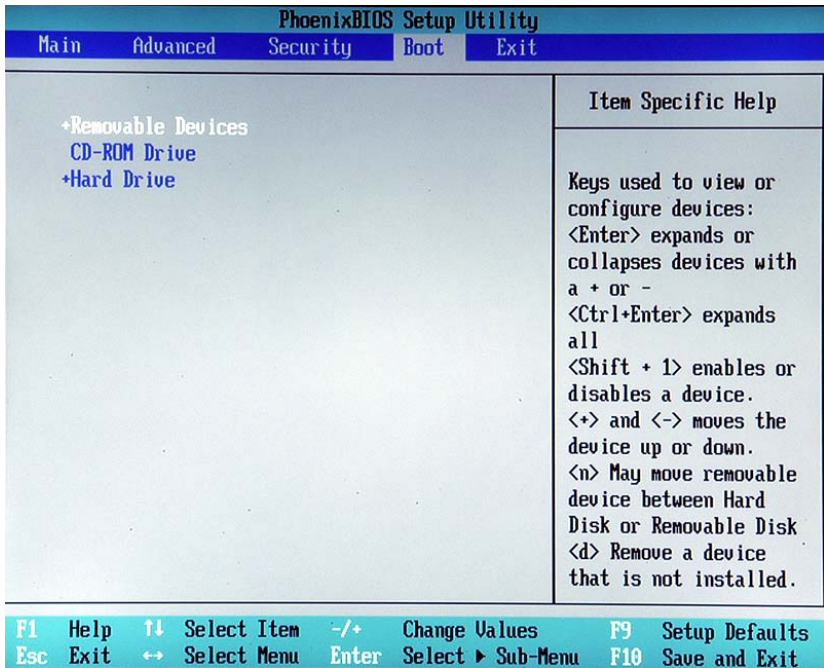

+Removable Devices

Highlight and press <Enter> to expand the field. See details on how to change the order and specs of devices in the Item Specific Help window.

CDROM Drive

See details on how to change the order and specs of the CDROM drive in the Item Specific Help window.

+Hard Drive

Highlight and press <Enter> to expand the field. See details on how to change the order and specs of hard drives in the Item Specific Help window.

7-7 Exit

Choose Exit from the Phoenix BIOS Setup Utility main menu with the arrow keys. You should see the following display.

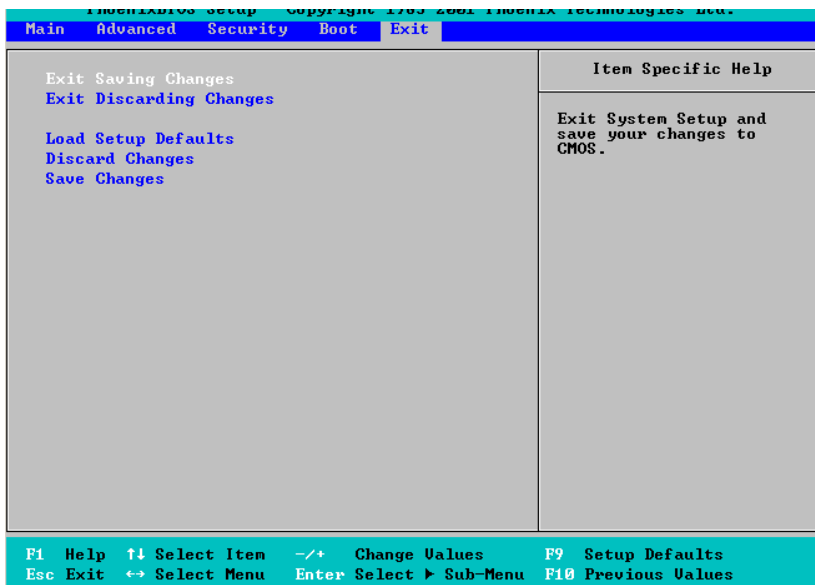

Exit Saving Changes

Highlight this item and hit <Enter> to save any changes you made and to exit the BIOS Setup utility.

Exit Discarding Changes

Highlight this item and hit <Enter> to exit the BIOS Setup utility without saving any changes you may have made.

Load Setup Defaults

Highlight this item and hit <Enter> to load the default settings for all items in the BIOS Setup. These are the safest settings to use.

Discard Changes

Highlight this item and hit <Enter> to discard (cancel) any changes you made. You will remain in the Setup utility.

Save Changes

Highlight this item and hit <Enter> to save any changes you made. You will remain in the Setup utility.

Notes

Appendix A

BIOS POST Codes

This section lists the POST (Power On Self Test) codes for the PhoenixBIOS. POST codes are divided into two categories: recoverable and terminal.

Recoverable POST Errors

When a recoverable type of error occurs during POST, the BIOS will display an POST code that describes the problem. BIOS may also issue one of the following beep codes:

- 1 long and two short beeps - video configuration error
- 1 continuous long beep - no memory detected

Terminal POST Errors

If a terminal type of error occurs, BIOS will shut down the system. Before doing so, BIOS will write the error to port 80h, attempt to initialize video and write the error in the top left corner of the screen.

The following is a list of codes that may be written to port 80h.

POSTCode	Description
02h	Verify Real Mode
03h	Disable Non-Maskable Interrupt (NMI)
04h	Get CPU type
06h	Initialize system hardware
07h	Disable shadow and execute code from the ROM.
08h	Initialize chipset with initial POST values
09h	Set IN POST flag
0Ah	Initialize CPU registers
0Bh	Enable CPU cache
0Ch	Initialize caches to initial POST values
0Eh	Initialize I/O component
0Fh	Initialize the local bus IDE
10h	Initialize Power Management
11h	Load alternate registers with initial POST values
12h	Restore CPU control word during warm boot
13h	Initialize PCI Bus Mastering devices
14h	Initialize keyboard controller
16h	1-2-2-3 BIOS ROM checksum
17h	Initialize cache before memory Auto size

POST Code	Description
18h	8254 timer initialization
1Ah	8237 DMA controller initialization
1Ch	Reset Programmable Interrupt Controller
20h	1-3-1-1 Test DRAM refresh
22h	1-3-1-3 Test 8742 Keyboard Controller
24h	Set ES segment register to 4 GB
28h	Auto size DRAM
29h	Initialize POST Memory Manager
2Ah	Clear 512 kB base RAM
2Ch	1-3-4-1 RAM failure on address line xxxx*
2Eh	1-3-4-3 RAM failure on data bits xxxx* of low byte of memory bus
2Fh	Enable cache before system BIOS shadow
32h	Test CPU bus-clock frequency
33h	Initialize Phoenix Dispatch Manager
36h	Warm start shut down
38h	Shadow system BIOS ROM
3Ah	Auto size cache
3Ch	Advanced configuration of chipset registers
3Dh	Load alternate registers with CMOS values
41h	Initialize extended memory for RomPilot
42h	Initialize interrupt vectors
45h	POST device initialization
46h	2-1-2-3 Check ROM copyright notice
47h	Initialize I20 support
48h	Check video configuration against CMOS
49h	Initialize PCI bus and devices
4Ah	Initialize all video adapters in system
4Bh	QuietBoot start (optional)
4Ch	Shadow video BIOS ROM
4Eh	Display BIOS copyright notice
4Fh	Initialize MultiBoot
50h	Display CPU type and speed
51h	Initialize EISA board
52h	Test keyboard
54h	Set key click if enabled
55h	Enable USB devices
58h	2-2-3-1 Test for unexpected interrupts
59h	Initialize POST display service
5Ah	Display prompt "Press F2 to enter SETUP"
5Bh	Disable CPU cache

POSTCode	Description
5Ch	Test RAM between 512 and 640 kB
60h	Test extended memory
62h	Test extended memory address lines
64h	Jump to UserPatch1
66h	Configure advanced cache registers
67h	Initialize Multi Processor APIC
68h	Enable external and CPU caches
69h	Setup System Management Mode (SMM) area
6Ah	Display external L2 cache size
6Bh	Load custom defaults (optional)
6Ch	Display shadow-area message
6Eh	Display possible high address for UMB recovery
70h	Display error messages
72h	Check for configuration errors
76h	Check for keyboard errors
7Ch	Set up hardware interrupt vectors
7Dh	Initialize Intelligent System Monitoring
7Eh	Initialize coprocessor if present
80h	Disable onboard Super I/O ports and IRQs
81h	Late POST device initialization
82h	Detect and install external RS232 ports
83h	Configure non-MCD IDE controllers
84h	Detect and install external parallel ports
85h	Initialize PC-compatible PnP ISA devices
86h	Re-initialize onboard I/O ports.
87h	Configure Motherboard Configurable Devices (optional)
88h	Initialize BIOS Data Area
89h	Enable Non-Maskable Interrupts (NMIs)
8Ah	Initialize Extended BIOS Data Area
8Bh	Test and initialize PS/2 mouse
8Ch	Initialize floppy controller
8Fh	Determine number of ATA drives (optional)
90h	Initialize hard-disk controllers
91h	Initialize local-bus hard-disk controllers
92h	Jump to UserPatch2
93h	Build MPTABLE for multi-processor boards
95h	Install CD ROM for boot
96h	Clear huge ES segment register
97h	Fix up Multi Processor table
98h	1-2 Search for option ROMs. One long, two short beeps on checksum failure

POST Code	Description
99h	Check for SMART Drive (optional)
9Ah	Shadow option ROMs
9Ch	Set up Power Management
9Dh	Initialize security engine (optional)
9Eh	Enable hardware interrupts
9Fh	Determine number of ATA and SCSI drives
A0h	Set time of day
A2h	Check key lock
A4h	Initialize typematic rate
A8h	Erase F2 prompt
AAh	Scan for F2 key stroke
ACh	Enter SETUP
A Eh	Clear Boot flag
B0h	Check for errors
B1h	Inform RomPilot about the end of POST.
B2h	POST done - prepare to boot operating system
B4h	1 One short beep before boot
B5h	Terminate QuietBoot (optional)
B6h	Check password (optional)
B7h	Initialize ACPI BIOS
B9h	Prepare Boot
BAh	Initialize SMBIOS
BBh	Initialize PnP Option ROMs
BCh	Clear parity checkers
BDh	Display MultiBoot menu
BEh	Clear screen (optional)
BFh	Check virus and backup reminders
C0h	Try to boot with INT 19
C1h	Initialize POST Error Manager (PEM)
C2h	Initialize error logging
C3h	Initialize error display function
C4h	Initialize system error handler
C5h	PnPnd dual CMOS (optional)
C6h	Initialize note dock (optional)
C7h	Initialize note dock late
C8h	Force check (optional)
C9h	Extended checksum (optional)
CAh	Redirect Int 15h to enable remote keyboard
CBh	Redirect Int 13h to Memory Technologies Devices such as ROM, RAM, PCMCIA, and serial disk
CCh	Redirect Int 10h to enable remote serial video

POST Code	Description
CDh	Re-map I/O and memory for PCMCIA
CEh	Initialize digitizer and display message
D2h	Unknown interrupt

The following are for boot block in Flash ROM

POST Code	Description
E0h	Initialize the chipset
E1h	Initialize the bridge
E2h	Initialize the CPU
E3h	Initialize system timer
E4h	Initialize system I/O
E5h	Check force recovery boot
E6h	Checksum BIOS ROM
E7h	Go to BIOS
E8h	Set Huge Segment
E9h	Initialize Multi Processor
EAh	Initialize OEM special code
EBh	Initialize PIC and DMA
ECh	Initialize Memory type
EDh	Initialize Memory size
EEh	Shadow Boot Block
EFh	System memory test
F0h	Initialize interrupt vectors
F1h	Initialize Run Time Clock
F2h	Initialize video
F3h	Initialize System Management Manager
F4h	Output one beep
F5h	Clear Huge Segment
F6h	Boot to Mini DOS
F7h	Boot to Full DOS

* If the BIOS detects error 2C, 2E, or 30 (base 512K RAM error), it displays an additional word-bitmap (**xxxx**) indicating the address line or bits that failed. For example, "2C 0002" means address line 1 (bit one set) has failed. "2E 1020" means data bits 12 and 5 (bits 12 and 5 set) have failed in the lower 16 bits. The BIOS also sends the bitmap to the port-80 LED display. It first displays the checkpoint code, followed by a delay, the high-order byte, another delay, and then the low-order byte of the error. It repeats this sequence continuously.

Notes

Appendix B

Software Installation

After all the hardware has been installed, you must first configure the Adaptec Embedded Serial ATA RAID Driver before you install the Windows operating system. The necessary drivers are all included on the Supermicro bootable CDs that came packaged with your motherboard. (For Adaptec's SCSI Host RAID Utility, please refer to the CDs that came with your motherboard.)

B-1 Adaptec Embedded SATA RAID Controller Driver

Serial ATA (SATA)

Serial ATA (SATA) is a physical storage interface. It uses a single cable with a minimum of four wires to create a point-to-point connection between devices. SATA is a serial link which supports transfer rates from 150 MBps. Because the serial cables used in SATA are thinner than the traditional cables used in Parallel ATA (PATA), SATA systems have better air-flow and can be installed in smaller chassis than Parallel ATA. In addition, the cables used in PATA can only extend to 40cm long, while SATA cables can extend up to one meter. Overall, SATA provides better functionality than PATA.

Configuring BIOS settings for the SATA RAID Functions

1. Press the **Del** key during system startup to enter the BIOS Setup Utility.

Note: If it is the first time to power on the system, we recommend that you load the Optimized Default Settings. If you have already done so, please skip to Step 3.

2. Use the arrow keys to select the "Exit" Menu. Once in the "Exit" Menu, scroll down the menu to select the item "Load Optimized Default Settings" and press the **Enter** key. Select **OK** to confirm the selection. Press the **Enter** key to load the default settings to the BIOS.

3. Use the arrow keys to select the "Main" Menu in BIOS.

4. Scroll down to the item "SATA RAID Enable", select **Enabled** and press **Enter**.

5. Tap the **Esc** key and scroll down to "Exit". Select "Save and Exit" from the "Exit" menu. Press the **Enter** key to save the changes and exit the BIOS.
6. Once you've exited the BIOS Utility, the system will re-boot.
7. During system startup, press the **Ctrl** and the **A** keys simultaneously to run the Adaptec RAID Configuration Utility when prompted by the message: "Press <Ctrl><A> for Adaptec RAID Configuration Utility".

Adaptec Embedded SATA with HostRAID Controller Driver

Adaptec's Embedded Serial ATA RAID with HostRAID controller adds RAID functionality to the Serial ATA I/O controller by supporting RAID 0 (Striping) or RAID 1 (Mirroring) to enhance the industry's pioneer PCI-to-e host controller products. RAID striping (RAID 0) can greatly improve hard disk I/O performance because of its capability in striping data across multiple drives. RAID mirroring (RAID 1) allows the data to be simultaneously written to two drives, so critical data is always available even if one hard disk fails.

Due to this built-in functionality, your Supermicro motherboard is specially designed to keep pace with the increasing performance demands of today's computer systems by improving disk I/O throughput and providing data accessibility regardless of a single disk failure. By incorporating Adaptec Embedded Serial ATA into the motherboard design, Supermicro offers the user the benefits of SATA RAID without the high costs associated with RAID hardware.

Note: For Adaptec's RAID Driver Installation Instructions, please refer to the Adaptec RAID Controller User's Guide: "Emb_SA_RAID_UG.pdf", which is located in the CD that came with this motherboard. You can also download a copy of Adaptec's User's Guide from our website at www.supermicro.com.

Using the Adaptec RAID Configuration Utility (ARC)

The Adaptec RAID Configuration Utility is an embedded BIOS Utility, including:

*Array Configuration Utility: Use this utility when you want to create, configure and manage arrays.

*Disk Utilities: Use this option to format or verify disks.

To run the Adaptec RAID Configuration Utility, you will need to enable the RAID function in the system BIOS (refer to Chapter 7 for System BIOS Configurations), and then press the **Ctrl** and **A** keys simultaneously when prompted to do so during the system startup. (Refer to the previous page for detailed instructions.)

Note: To select an option, use the arrow keys to highlight the item and then press the **Enter** key to select it. To return to the previous menu, press the **ESC** key.

Using the Array Configuration Utility (ACU)

The Array Configuration Utility (ACU) enables you to create, manage, and delete arrays from the controller's BIOS, add and delete spare drives, and initialize drives. During the system startup, press the **Ctrl** and **A** keys simultaneously, and the main menu will appear.

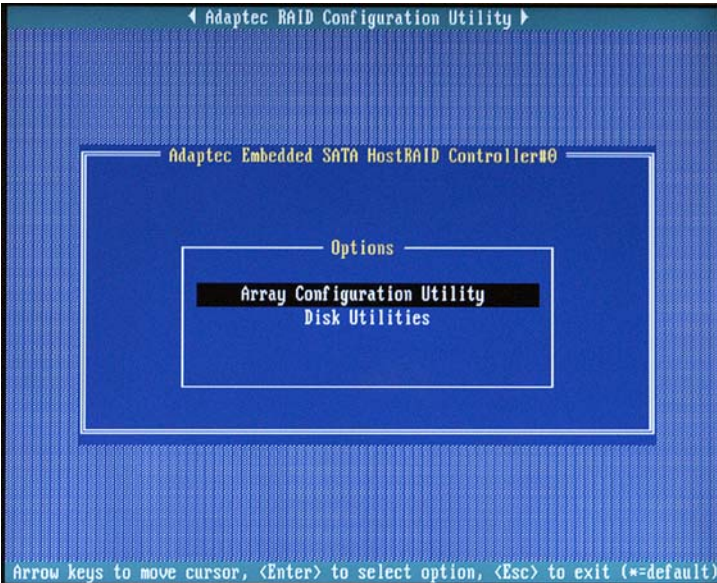

Managing Arrays

Select this option to view array properties and delete arrays. The following sections describe the operations of "Managing Arrays".

To select this option, use the arrow keys and the **Enter** key to select **Managing Arrays** from the main menu (as shown below).

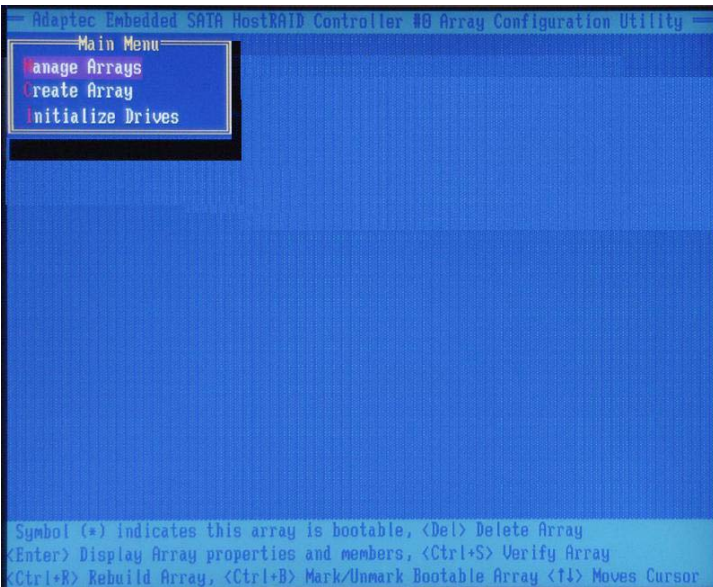

Viewing Array Properties

To view the properties of an existing array:

1. At the BIOS prompt, press **Ctrl+A**.
2. From the ARC menu, select **Array Configuration Utility (ACU)**.
3. From the ACU menu, select **Manage Arrays** (as shown on the previous screen.)
4. From the List of Arrays dialog box, select the array you want to view and press **Enter**.

The Array Properties dialog box appears, showing detailed information on the array. The physical disks associated with the array are displayed here.

5. Press **Esc** to return to the previous menu.

Deleting Arrays

Warning: *Back up the data on an array before you delete it to prevent the loss of data. Deleted arrays cannot be restored.*

1. Turn on your computer and press **Ctrl+A** when prompted to access the ARC utility.
2. From the ARC main menu, select **Array Configuration Utility (ACU)**.
3. From the ACU menu, select **Manage Arrays**.
4. Select the array you wish to delete and press **Delete**.
5. In the Array Properties dialog box, select **Delete** and press **Enter**. The following prompt is displayed:

Warning!! Deleting the array will render array unusable. Do you want to delete the array?(Yes/No):

RAID 1 only - the following prompt is also displayed:

Deleting the partition will result in data loss! Do you also want to delete the partition? (Yes/No):

6. Press **Yes** to delete the array or partition or **No** to return to the previous menu.
7. Press **Esc** to return to the previous menu.

Creating Arrays

Before creating arrays, make sure the disks for the array are connected and installed in your system. Note that disks with no usable space, or disks that are un-initialized are shown in gray and cannot be used. See *Initializing Disk Drives*.

To create an array

1. Turn on your computer and press **Ctrl+A** when prompted to access the ARC utility.
2. From the ARC menu, select **Array Configuration Utility Main Menu (ACU)** (as shown on the first screen on page B-4).
3. From the ACU menu select **Create Array**.
4. Select the disks for the new array and press **Insert** (as shown on the the screen below).

Note: To deselect any disk, highlight the disk and press **Delete**.

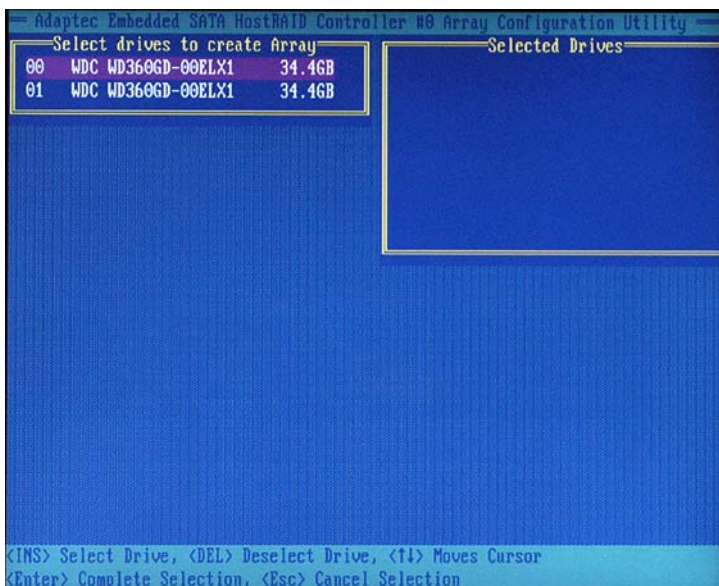

5. Press **Enter** when both disks for the new array are selected. The Array Properties menu displays (as the shown on the screen on the next page).

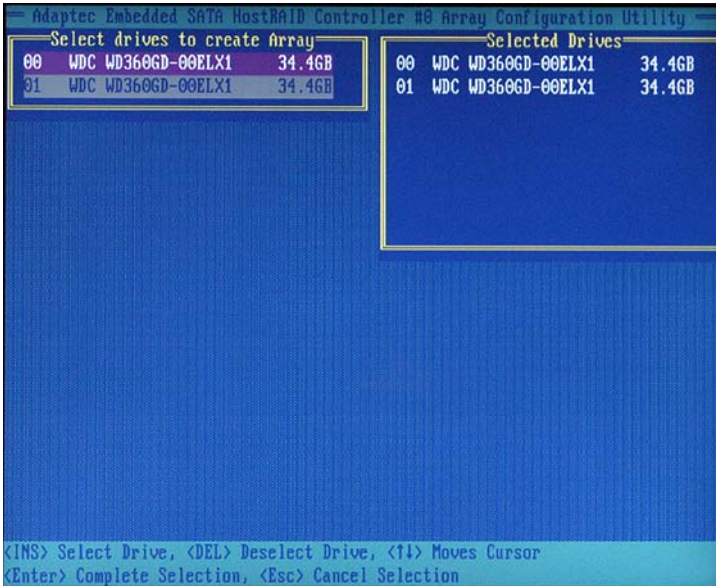

Assigning Array Properties

Once you've create a new array, you are ready to assign properties to the array.

Caution: Once the array is created and its properties are assigned, you cannot change the array properties using the ACU. You will need to use the Adaptec Storage Manager - Browser Edition. (Refer to Adaptec's User's Guide in the enclosed CD.)

To assign properties to the new array

1. In the Array Properties menu (as shown on the following screen), select an array type and press **Enter**.

Note that only the available array types (RAID 0 and RAID 1) are displayed on the screen. (Using RAID 0 or RAID 1 requires two drives.)

2. Under the item "**Arrays Label**", type in a label and press **Enter**. The label cannot be more than 15 characters.

3. For RAID 0, select the desired stripe size. (Available stripe sizes are 16, 32, and 64 KB - default. It is recommended that you *do not* change the default setting.)

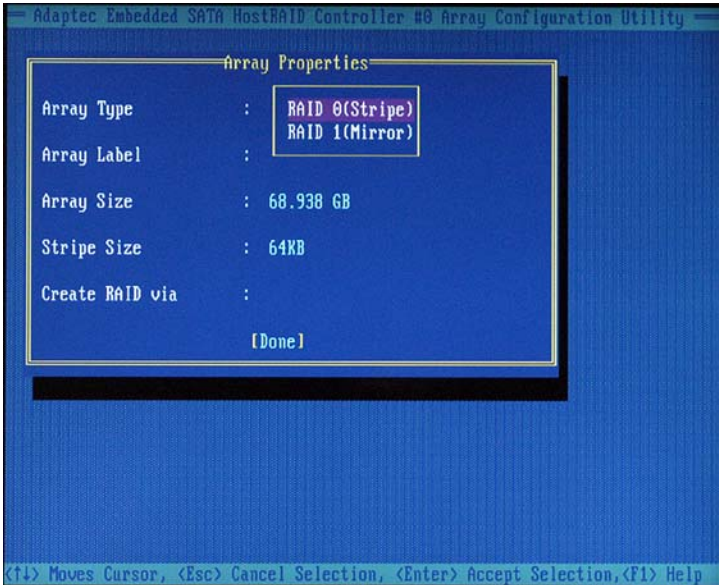

4. The item "Create RAID via" allows you to select between the different methods of creating RAID 0 and RAID 1.

The following table gives examples of when each is appropriate.

Raid Level	Create Via	When Appropriate
RAID 0	No Init	Creating a RAID 0 on new drives
RAID 0	Migrate (*Note)	Creating a RAID 0 from one new drive and one drive with data you wish to preserve
RAID 1	Build1	Any time you wish to create a RAID 1, but especially if you have data on one drive that you wish to preserve
RAID 1	Clear	Creating a RAID 1 on new drives, or when you want to ensure that the array contains no data after creation.
RAID 1	Quick	Fastest way to create a RAID 1. Appropriate when using new drives
RAID 1	Init	

5. When finished, press **Done** (as shown on the following screen).

Note: If you select Migrate for RAID 0, or Build for RAID 1, you will be asked to select the source drive. The contents of the source drive will be preserved. However, the data on the new drive will be lost.

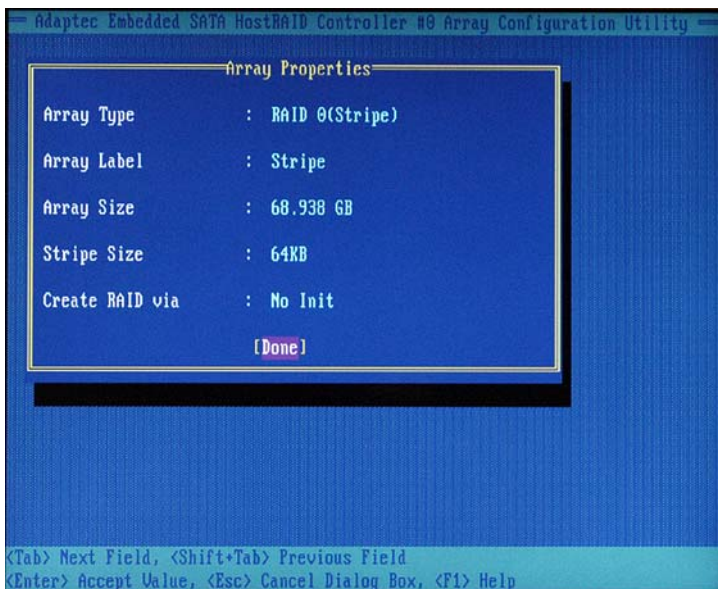

Notes

1. Before adding a new drive to an array, back up any data contained on the new drive. Otherwise, all data will be lost.
2. If you stop the build or clear process on a RAID 1 from ACU, you can restart it by pressing **Ctrl+R**.
3. A RAID 1 created using the Quick Init option may return some data mismatches if you later run a consistency check. This is normal and is not a cause for concern.
4. The ACU allows you to use drives of different sizes in a RAID. However, during a build operation, only the smaller drive can be selected as the source or first drive.
5. When migrating from single volume to RAID 0, migrating from a larger drive to a smaller drive is allowed. However, the destination drive must be at least half the capacity of the source drive.
6. Adaptec does not recommend that you migrate or build an array on Windows dynamic disks (volumes), as it will result in data loss.

Warning: Do not interrupt the creation of RAID 0 using the Migrate option. If you do, you will not be able to restart or to recover the data that was on the source drive.

Adding a Bootable Array

1. From the Main menu, select **Manage Arrays**.
2. From the list of arrays, select the array you want to make bootable and press **Ctrl+B**.
3. Enter **Y** to create a bootable array when the following message is displayed: "This will make all other existing bootable array non-bootable. Do you want to make this array bootable? (Yes/No):" A bootable array will then be created. An asterisk will appear next to the bootable array.

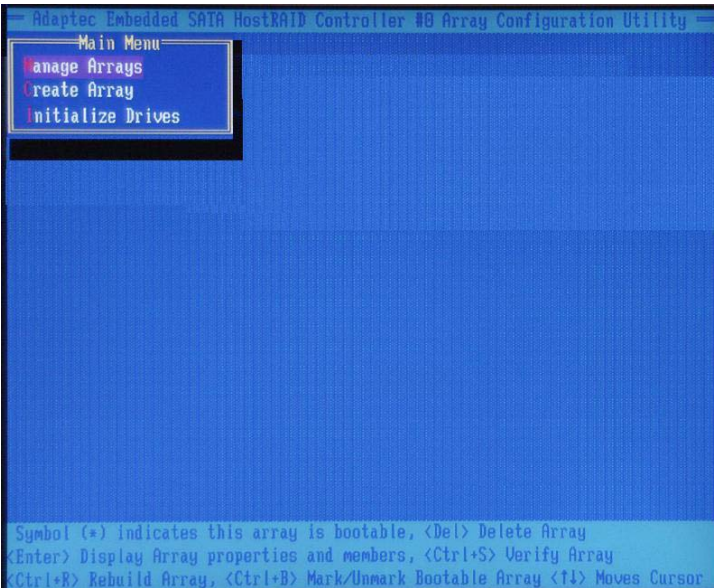

Deleting a Bootable Array

To delete a bootable array

1. From the Main menu, select **Manage Arrays**.
2. From the List of Arrays, select the bootable array (*) you want to delete and press **Ctrl+B**. (A bootable array is an array marked with an asterisk.)
3. Enter **Y** to delete a bootable array when the following message is displayed: "The array is already marked bootable. Do you want to make this array as not bootable? (Yes/No):" The bootable array will then be deleted and the asterisk will disappear.

Note: do not use the delete key to delete a bootable array.

Adding/Deleting Hotspares

Note: In order to rebuild a RAID (RAID 0 or RAID 1), you need to add a new HDD as a hotspare.

1. Turn on your computer and press **Ctrl+A** as prompted to access the ARC Utility.
2. From the ARC menu, select **Array Configuration Utility (ACU)**.
3. From the ACU menu, select **Add/Delete Hotspares**.
4. Use the up and down arrow keys to highlight and select the disk you want to designate as a hotspare, and press **Insert**, then press **Enter**.
5. Select **Yes** when the following prompt is displayed:

"Do you want to create spare?" (Yes/No?)

The spare you have selected will appear in the Select Drive Menu.

Initializing Disk Drives

If an installed disk does not appear in the disk selection list for creating a new array or if it appears grayed out, you may have to initialize it before you can use it as part of an array. Drives attached to the controller must be initialized before they can be used in an array.

Caution: Initializing a disk overwrites the partition table on the disk and makes any data on the disk inaccessible. If the drive is used in an array, you may not be able to use the array again.

Do not initialize a disk that is part of a boot array. To determine which disks are associated with a particular array, please refer to *Viewing Array Properties*.

To initialize drives:

1. Turn on your computer and press **Ctrl+A** when prompted to access the ARC utility.
2. From the ARC menu, select **Array Configuration Utility (ACU)** (as shown on the screen below).

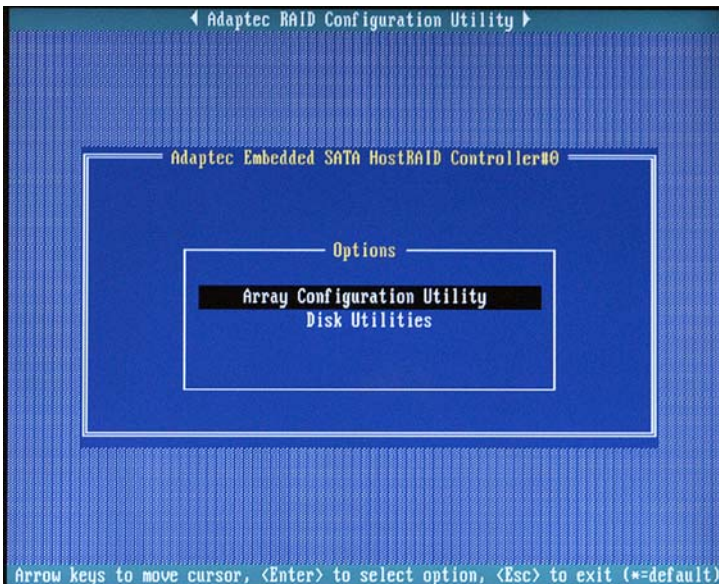

3. Select **Initialize Drives**.
4. Use the up and down arrow keys to highlight the disk you wish to initialize and press **Insert** (as shown on the following screen).

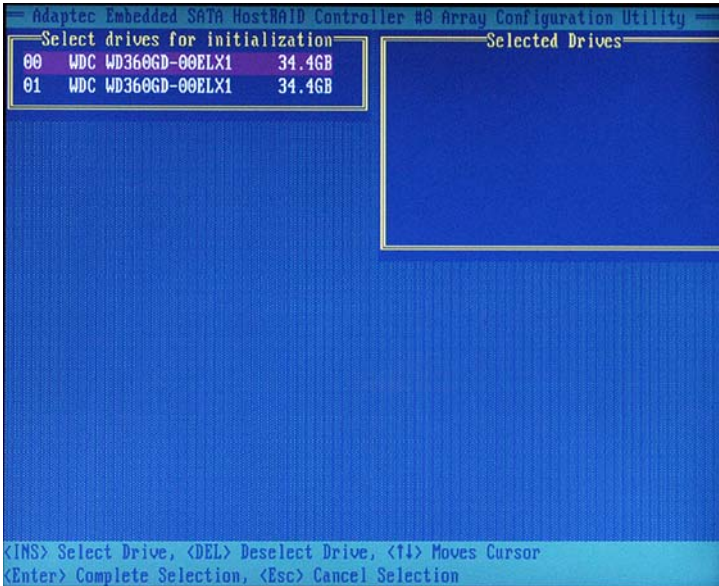

5. Repeat Step 4 so that both drives to be initialized are selected (as shown on the following screen).

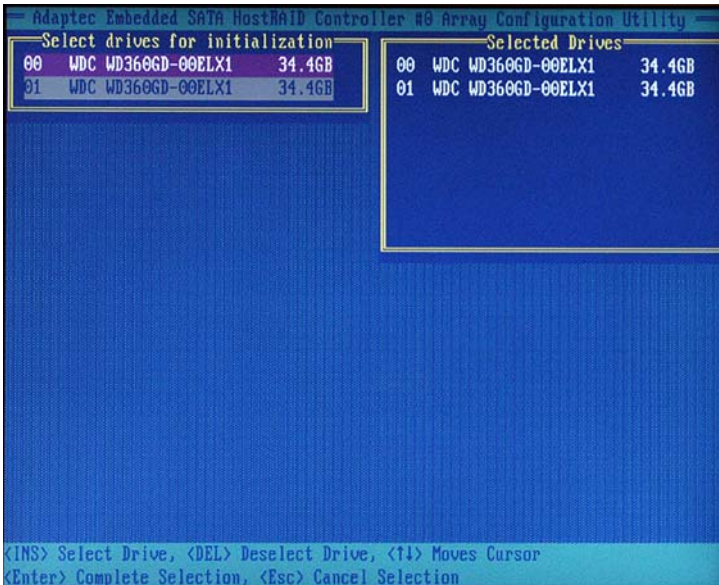

6. Press **Enter**.
7. Read the warning message as shown on the screen below.

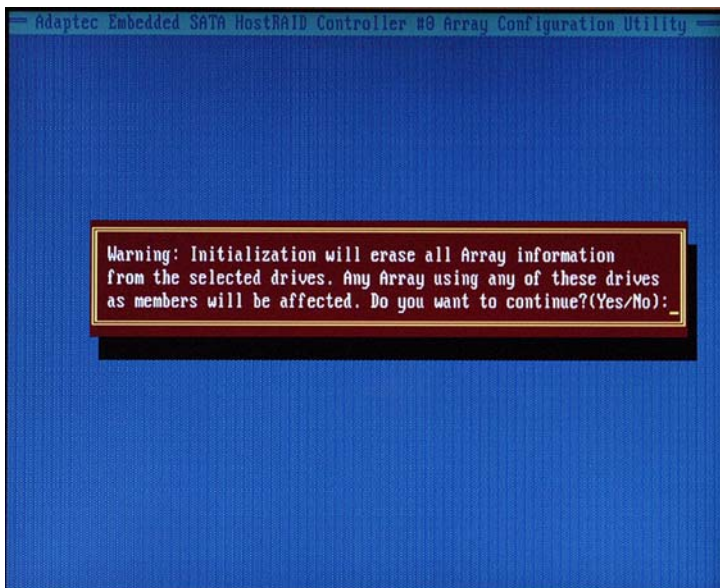

8. Make sure that you have selected the correct disk drives to initialize. If correct, type **Y** to continue.

Rebuilding Arrays

Note 1: Rebuilding applies to Fault Tolerant arrays (RAID 1) only.

If an array build process (or initialization) is interrupted or critical with one member missing, you must perform a rebuild to optimized its functionality. For a critical array rebuild operation, the optimal drive is the source drive.

Note 2: If no spare array exists and a hard disk drive fails, you need to create a spare before you can rebuild an array.

To Rebuild an array:

1. From the Main Menu, select **Manage Arrays**. From the list of arrays, select the array you want to rebuild.
2. Press **Ctrl+R** to rebuild.

Using the Disk Utilities

The Disk Utilities enable you to format or verify the media of your Serial ATA hard disks.

To access the disk utilities:

1. Turn on your computer and press **Ctrl+A** when prompted to access the ARC utility.
2. From the ARC menu, select **Disk Utilities**.
3. Select the desired disk and press **Enter** (as shown below.)

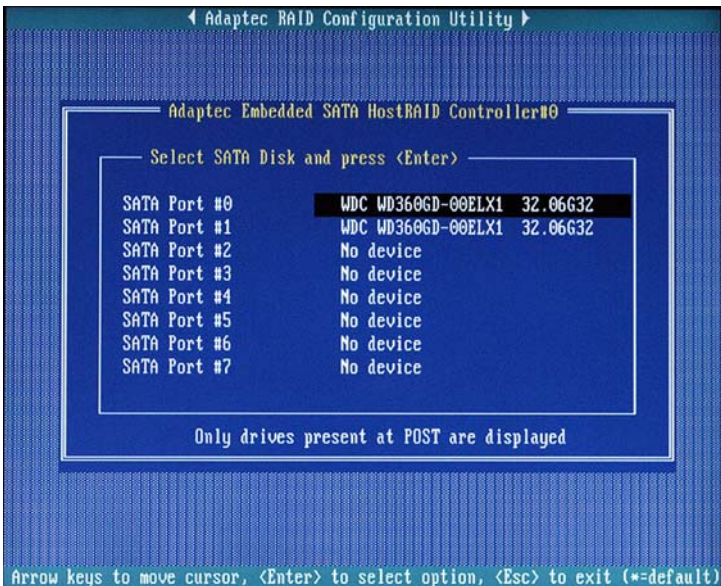

You can choose from the following options

1. Format Disk - Simulates a low-level format of the hard drive by writing zeros to the entire disk. Serial ATA drives are low-level formatted at the factory and do not need to be low-level formatted again.

Caution: Formatting destroys all data on the drive. Be sure to back up your data before performing this operation.

2. Verify Disk Media - Scans the media of a disk drive for defects.

To Exit Adaptec RAID Configuration Utility

1. Once you have completed RAID array configurations, press **ESC** to exit. The following screen will appear.

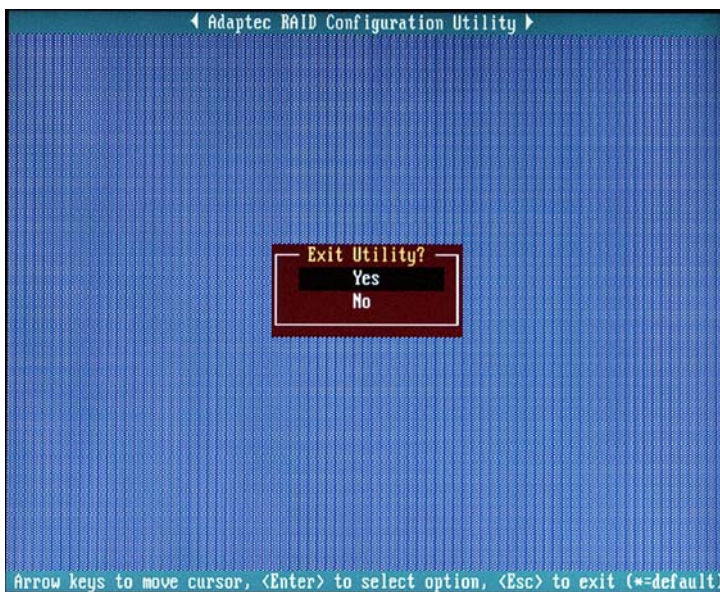

2. Press **Yes** to exit the Utility.

For more information regarding the Adaptec RAID Utility, please refer to Adaptec's User's Guide in the CD included in your shipping package. You can also download a copy of Adaptec User's Guide from our web site at: www.supermicro.com.

B-2 Installing Intel's 6300ESB Driver by Adaptec and Windows OS

1. Insert Supermicro's bootable CD that came with the package into the CD drive during the system reboot. The "Super Micro Driver Diskette Maker" screen will appear.
2. Choose "Intel Hance Rapids Driver by 3rd Party (Adaptec)" from the items listed and press **Enter**.
3. From the next screen displayed, choose the OS driver you want to install and press **Enter**.
4. Insert a formatted diskette into drive A: and press **Enter** as prompted.
5. Exit the program after the process is completed. Then, reboot the system.
6. Insert Microsoft Windows OS Setup CD in the CD Driver. The system will boot up from the CD.
7. Press the **F6** key when the message "Press F6 if you need to install a third party SCSI or RAID driver" is displayed.
8. When the Windows OS Setup screen appears, press **S** to specify additional device(s).
9. Insert the driver diskette labelled "Adaptec Embedded Serial ATA Raid Controller Driver" into your floppy drive and press the **Enter** key.
10. Choose **Adaptec Embedded Host Serial ATA Raid Controller** from the list indicated in the Windows OS Setup Screen and press the **Enter** key.
11. Press the **Enter** key to continue the installation process. (If you need to specify any additional devices to be installed, do so at this time.) Once all devices are specified, press the **Enter** key to continue with the installation.
12. From the Windows OS Setup screen, press the **Enter** key. The OS setup routine will automatically load all device files and continue the Windows OS installation.
13. After the Windows OS installation has completed, the system will automatically reboot.

B-3 Installing Other Software Programs and Drivers

Installing Other Drivers

After you've installed the Windows Operating System, a screen (as shown in Figure B-1) will appear. You are now ready to install additional software programs and drivers. To install these software programs and drivers, click the icons to the right of these items.

Figure B-1. Driver/Tool Installation Display Screen

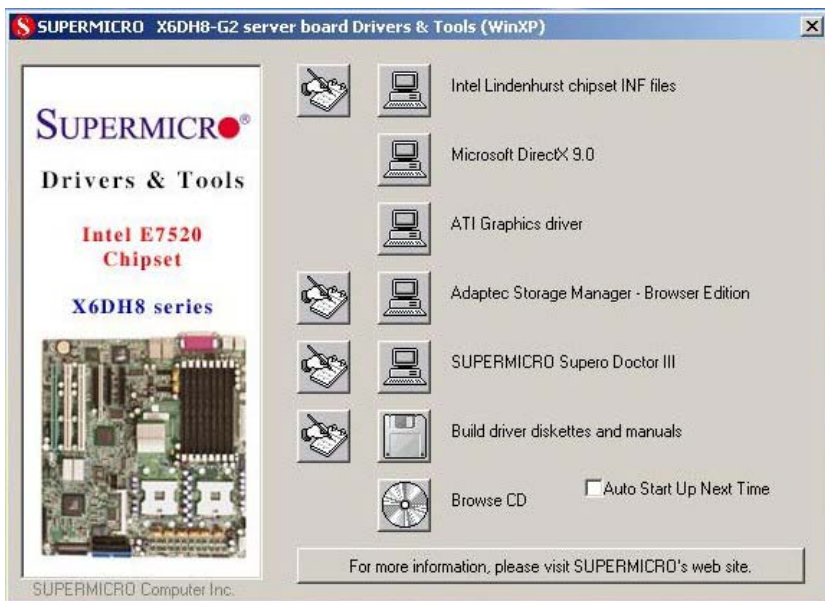

Click the icons showing a hand writing on paper to view the readme files for each item. Click the computer icons to the right of these items (from top to the bottom) one at a time. **After installing each item, you must re-boot the system before moving on to the next item on the list.** You should install everything here except for the SUPER Doctor utility, Intel LDCM and the LAN/SCSI driver diskettes, which are optional. The bottom icon with a CD on it allows you to view the entire contents of the CD.

Note: Please refer to the Adaptec User's Guide (included in the CD) for installing the Adaptec SATA RAID Controller Driver. You can also download a copy of the guide from our website.

Supero Doctor III

The Supero Doctor III program is a web-based management tool that offers both remote and local management tools. The local management application is called SD III Client. The Supero Doctor III program included on the CDROM that came with your motherboard allows you to monitor the environment and operations of your system. Supero Doctor III displays crucial system information such as CPU temperature, system voltages and fan status. See Figures B-2 and B-3 for examples of the Supero Doctor III interface.

Figure B-2. Supero Doctor III: Health Information Display

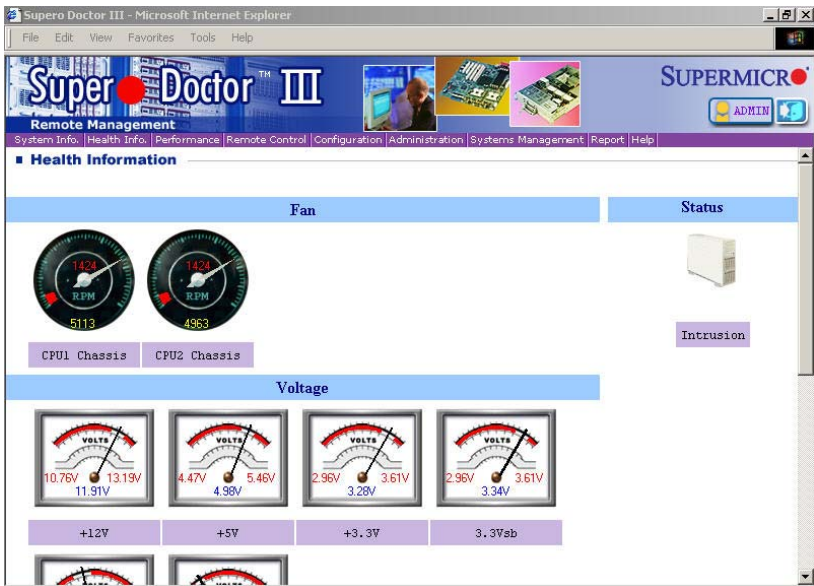

Figure B-3. Supero Doctor III: Remote Control Display

Graceful power control

Supero Doctor III allows a user to inform the OS to reboot or shut down within a specified time (the default is 30 seconds). Before the system reboots or shuts down, it's allowed to cancel the action.

Requirements

Keep Supero SD3Service Daemon running at all times on this system.
Provide TCP/IP connectivity.

Power control

Note: SD III Software Revision 1.0 can be downloaded from our Web site at: ftp://ftp.supermicro.com/utility/Supero_Doctor_III/. You can also download the SDIII User's Guide at: <http://www.supermicro.com/PRODUCTION/Manuals/SDIII/UserGuide.pdf>. For Linux, we recommend using Supero Doctor II.

Appendix C

System Specifications

Processors

Single or dual 604-pin Intel® Xeon™ EM64T processors at a front side (system) bus speed of 800 MHz. (Please refer to the support section of our web site for a complete listing of supported processors.)

Chipset

Intel E7520 chipset

BIOS

8 MB Phoenix® Flash ROM

Memory Capacity

Eight 184-pin DIMM sockets supporting up to 16 GB of registered ECC DDR333 or up to 32 GB of registered ECC DDR266 SDRAM

Note: Interleaved memory - requires memory to be installed two at a time. See the memory section in Chapter 5 for details.

SCSI Controller (6024H-8R only)

Adaptec AIC-7902 for dual channel Ultra320 onboard SCSI

SCSI Backplane Controller (6024H-8R only)

CSE-SCA-822: SAF-TE compliant backplane supports six (6) SCA hot-swap SCSI drives

Peripheral Drives/Bays

One (1) 3.5" floppy drive

One (1) slim CD-ROM drive

One (1) 5.25" drive bay

Six (6) SCSI drive bay carriers (6024H-8R)

Two (2) carriers (3 drives in each) to house up to six (6) IDE drives (6024H-i)

Expansion Slots

Chassis: Seven (7) I/O chassis slots

Serverboard: total of six (6) PCI-Express/PCI-X/PCI slots

Serverboard: 6024H-8R/6024H-i

Model: X6DH8-G/X6DHE-G (Extended ATX)

Dimensions: 12 x 13 in (305 x 330 mm)

Chassis: 6024H-8R/6024H-i

Model: SC823S-R500LP/SC823i-550LP (2U rackmount)

Dimensions: (WxHxD) 16.7 x 89 x 25.6 in. (424 x 434 x 650 mm)

Weight

Gross (Bare Bone): 57/54 lbs. (25.6/24.5 kg.)

System Cooling

Four (4) 8-cm, 6300 rpm chassis cooling fans (hot-swappable)

One (1) air shroud for 2U rackmount system

System Input Requirements

AC Input Voltage: 100-240 VAC

Rated Input Current, PWS-049:10A max.

PWS-047: 9A (115V) to 3.5A (230V)

Rated Input Frequency: 50-60 Hz

Power Supply (6024H-8R)

Rated Output Power: 500W (Model# SP502-2S, Part# PWS-0049)

Rated Output Voltages: +3.3V (21A), +5V (30A), -5V (0.8A), 12V_{ALL} (39A), +5Vsb (2.0A)

Power Supply (6024H-i)

Rated Output Power: 550W (Model# SP552-2C, Part# PWS-0047)

Rated Output Voltages: +3.3V (30A), +5V (35A), 12V_{ALL} (42A), +5Vsb (2.0A)

Operating Environment

Operating Temperature: 10° to 35° C (50° to 95° F)

Non-operating Temperature: -40° to 70° C (-40° to 158° F)

Operating Relative Humidity: 5% to 90% (non-condensing)

Non-operating Relative Humidity: 5 to 95% (non-condensing)

Regulatory Compliance

Electromagnetic Emissions:

FCC Class B, EN 55022 Class B, EN 61000-3-2/-3-3, CISPR 22 Class B

Electromagnetic Immunity:

EN 55024/CISPR 24, (EN 61000-4-2, EN 61000-4-3, EN 61000-4-4,
EN 61000-4-5, EN 61000-4-6, EN 61000-4-8, EN 61000-4-11)

Safety:

EN 60950/IEC 60950-Compliant

UL Listed (USA)

CUL Listed (Canada)

TUV Certified (Germany)

CE Marking (Europe)

Notes