

# SUPERO®

SUPERSERVER 6025B-TR+  
SUPERSERVER 6025B-8R+

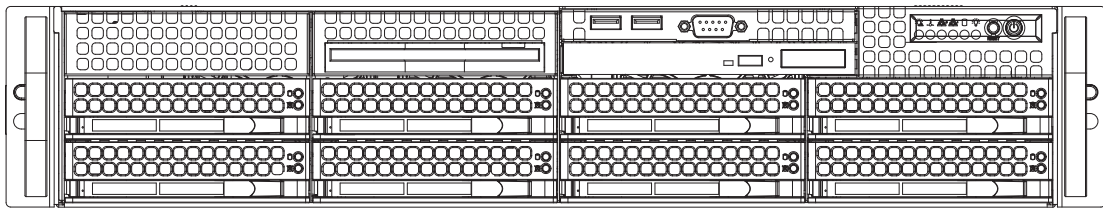

USER'S MANUAL

1.0c

---

The information in this User's Manual has been carefully reviewed and is believed to be accurate. The vendor assumes no responsibility for any inaccuracies that may be contained in this document, makes no commitment to update or to keep current the information in this manual, or to notify any person or organization of the updates. **Please Note: For the most up-to-date version of this manual, please see our web site at [www.supermicro.com](http://www.supermicro.com).**

Super Micro Computer, Inc. ("Supermicro") reserves the right to make changes to the product described in this manual at any time and without notice. This product, including software, if any, and documentation may not, in whole or in part, be copied, photocopied, reproduced, translated or reduced to any medium or machine without prior written consent.

IN NO EVENT WILL SUPERMICRO BE LIABLE FOR DIRECT, INDIRECT, SPECIAL, INCIDENTAL, SPECULATIVE OR CONSEQUENTIAL DAMAGES ARISING FROM THE USE OR INABILITY TO USE THIS PRODUCT OR DOCUMENTATION, EVEN IF ADVISED OF THE POSSIBILITY OF SUCH DAMAGES. IN PARTICULAR, SUPERMICRO SHALL NOT HAVE LIABILITY FOR ANY HARDWARE, SOFTWARE, OR DATA STORED OR USED WITH THE PRODUCT, INCLUDING THE COSTS OF REPAIRING, REPLACING, INTEGRATING, INSTALLING OR RECOVERING SUCH HARDWARE, SOFTWARE, OR DATA.

Any disputes arising between manufacturer and customer shall be governed by the laws of Santa Clara County in the State of California, USA. The State of California, County of Santa Clara shall be the exclusive venue for the resolution of any such disputes. Super Micro's total liability for all claims will not exceed the price paid for the hardware product.

FCC Statement: This equipment has been tested and found to comply with the limits for a Class A digital device pursuant to Part 15 of the FCC Rules. These limits are designed to provide reasonable protection against harmful interference when the equipment is operated in a commercial environment. This equipment generates, uses, and can radiate radio frequency energy and, if not installed and used in accordance with the manufacturer's instruction manual, may cause harmful interference with radio communications. Operation of this equipment in a residential area is likely to cause harmful interference, in which case you will be required to correct the interference at your own expense.

California Best Management Practices Regulations for Perchlorate Materials: This Perchlorate warning applies only to products containing CR (Manganese Dioxide) Lithium coin cells. "Perchlorate Material-special handling may apply. See [www.dtsc.ca.gov/hazardouswaste/perchlorate](http://www.dtsc.ca.gov/hazardouswaste/perchlorate)"

---

**WARNING: Handling of lead solder materials used in this product may expose you to lead, a chemical known to the State of California to cause birth defects and other reproductive harm.**

---

Manual Revision 1.0c  
Release Date: December 18, 2008

Unless you request and receive written permission from Super Micro Computer, Inc., you may not copy any part of this document.

Information in this document is subject to change without notice. Other products and companies referred to herein are trademarks or registered trademarks of their respective companies or mark holders.

Copyright © 2008 by Super Micro Computer, Inc.  
All rights reserved.

**Printed in the United States of America**

## Preface

### About This Manual

This manual is written for professional system integrators and PC technicians. It provides information for the installation and use of the SuperServer 6025B-TR+/6025B-8R+. Installation and maintenance should be performed by experienced technicians only.

The SuperServer 6025B-TR+/6025B-8R+ is a high-end server based on the SC825TQ-R700LP/SC825S2-R700LP 2U rackmount chassis and the X7DBE+/X7DB8+, a dual processor serverboard that supports dual Intel® Xeon™ LGA 771 processors at a Front Side (System) Bus speed of 1333 MHz and up to 64 GB of registered FBD ECC DDR2-667/533 SDRAM.

### Manual Organization

#### Chapter 1: Introduction

The first chapter provides a checklist of the main components included with the server system and describes the main features of the X7DBE+/X7DB8+ serverboard and the SC825TQ-R700LP/SC825S2-R700LP chassis, which comprise the SuperServer 6025B-TR+/6025B-8R+.

#### Chapter 2: Server Installation

This chapter describes the steps necessary to install the SuperServer 6025B-TR+/6025B-8R+ into a rack and check out the server configuration prior to powering up the system. If your server was ordered without processor and memory components, this chapter will refer you to the appropriate sections of the manual for their installation.

#### Chapter 3: System Interface

Refer here for details on the system interface, which includes the functions and information provided by the control panel on the chassis as well as other LEDs located throughout the system.

## **Chapter 4: System Safety**

You should thoroughly familiarize yourself with this chapter for a general overview of safety precautions that should be followed when installing and servicing the SuperServer 6025B-TR+/6025B-8R+.

## **Chapter 5: Advanced Serverboard Setup**

Chapter 5 provides detailed information on the X7DBE+/X7DB8+ serverboard, including the locations and functions of connections, headers and jumpers. Refer to this chapter when adding or removing processors or main memory and when reconfiguring the serverboard.

## **Chapter 6: Advanced Chassis Setup**

Refer to Chapter 6 for detailed information on the SC825TQ-R700LP/SC825S2-R700LP server chassis. You should follow the procedures given in this chapter when installing, removing or reconfiguring SATA/SCSI or peripheral drives and when replacing system power supply units and cooling fans.

## **Chapter 7: BIOS**

The BIOS chapter includes an introduction to BIOS and provides detailed information on running the CMOS Setup Utility.

## **Appendix A: BIOS POST Messages**

## **Appendix B: BIOS POST Codes**

## **Appendix C: Software Installation**

## **Appendix D: System Specifications**

## Notes

# Table of Contents

## Preface

About This Manual .....	iii
Manual Organization .....	iii

## Chapter 1: Introduction

1-1 Overview .....	1-1
1-2 Serverboard Features .....	1-2
1-3 Server Chassis Features .....	1-4
1-4 Contacting Supermicro .....	1-6

## Chapter 2: Server Installation

2-1 Overview .....	2-1
2-2 Unpacking the System .....	2-1
2-3 Preparing for Setup .....	2-1
2-4 Installing the System into a Rack .....	2-4
2-5 Checking the Serverboard Setup .....	2-8
2-6 Checking the Drive Bay Setup .....	2-10

## Chapter 3: System Interface

3-1 Overview .....	3-1
3-2 Control Panel Buttons .....	3-1
Reset .....	3-1
Power .....	3-1
3-3 Control Panel LEDs .....	3-2
Power Fail .....	3-2
Overheat/Fan Fail .....	3-2
NIC1 .....	3-2
NIC2 .....	3-2
HDD .....	3-3
Power .....	3-3
3-4 Drive Carrier LEDs .....	3-3

## Chapter 4: System Safety

4-1 Electrical Safety Precautions .....	4-1
4-2 General Safety Precautions .....	4-2
4-3 ESD Precautions .....	4-3
4-4 Operating Precautions .....	4-4

---

**Chapter 5: Advanced Serverboard Setup**

5-1	Handling the Serverboard .....	5-1
5-2	Processor and Heatsink Installation .....	5-2
5-3	Connecting Cables .....	5-5
	Connecting Data Cables .....	5-5
	Connecting Power Cables .....	5-5
	Connecting the Control Panel .....	5-6
5-4	I/O Ports .....	5-7
5-5	Installing Memory .....	5-7
5-6	Adding PCI Cards .....	5-9
5-7	Serverboard Details .....	5-10
	X7DB8+ Layout .....	5-10
	X7DB8+/X7DBE+ Quick Reference .....	5-11
5-8	Connector Definitions .....	5-12
	ATX Power Connector .....	5-12
	Secondary Power Connector .....	5-12
	Processor Power Connector .....	5-12
	NMI Button .....	5-12
	Power LED .....	5-12
	HDD LED .....	5-13
	NIC1 LED .....	5-13
	NIC2 LED .....	5-13
	Overheat/Fan Fail LED .....	5-13
	Power Fail LED .....	5-13
	Reset Button .....	5-14
	Power Button .....	5-14
	Universal Serial Bus (USB0/1) .....	5-14
	Chassis Intrusion .....	5-14
	Serial Ports .....	5-15
	Power Fail Header .....	5-15
	Fan Headers .....	5-15
	Extra Universal Serial Bus Headers .....	5-16
	Power LED/Speaker .....	5-16
	ATX PS/2 Keyboard and Mouse Ports .....	5-16
	Overheat LED .....	5-16
	Wake-On-LAN .....	5-17
	Wake-On-Ring .....	5-17
	SMB .....	5-17
	SMBUS_PS .....	5-17

---

	SGPIO .....	5-18
5-9	Jumper Settings .....	5-18
	Explanation of Jumpers .....	5-18
	CMOS Clear .....	5-18
	JLAN Enable/Disable .....	5-19
	Watch Dog Enable/Disable .....	5-19
	3rd Power Supply Fail Detect Enable/Disable .....	5-19
	Alarm Reset .....	5-20
	VGA Enable/Disable .....	5-20
	SCSI Controller Enable/Disable .....	5-20
	SCSI Termination Enable/Disable .....	5-20
	Compact Flash Master/Slave Select .....	5-21
	SMBUS to PCI Enable/Disable .....	5-21
5-10	Onboard Indicators .....	5-22
	JLAN1/JLAN2 LEDs .....	5-22
	SCSI Activity LED Indicators .....	5-22
	Onboard Power LED .....	5-22
5-11	Parallel Port, Floppy and Hard Drive Connections .....	5-23
	Parallel Port Connector .....	5-23
	Floppy Connector .....	5-24
	SATA Ports .....	5-24
	IDE Connectors .....	5-25
	Ultra320 SCSI Connectors .....	5-26

## Chapter 6: Advanced Chassis Setup

6-1	Static-Sensitive Devices .....	6-1
6-2	Control Panel .....	6-2
6-3	System Fans .....	6-3
	System Fan Failure .....	6-3
	Replacing System Fans .....	6-3
6-4	Drive Bay Installation .....	6-4
	SATA/SCSI Drive Installation .....	6-5
	DVD-ROM and Floppy Drive Installation .....	6-7
6-5	Power Supply .....	6-8
	Power Supply Failure .....	6-8
	Removing/Replacing the Power Supply .....	6-8

**Chapter 7: BIOS**

7-1	Introduction .....	7-1
7-2	Running Setup .....	7-2
7-3	Main BIOS Setup .....	7-2
7-4	Advanced Setup .....	7-7
7-5	Security .....	7-19
7-6	Boot .....	7-20
7-7	Exit .....	7-21

**Appendices:**

Appendix A: BIOS POST Messages

Appendix B: BIOS POST Codes

Appendix C: Software Installation

Appendix D: System Specifications

**Notes**

# Chapter 1

## Introduction

### 1-1 Overview

The SuperServer 6025B-TR+/6025B-8R+ is a high-end server that is comprised of two main subsystems: the SC825TQ-R700LP/SC825S2-R700LP 2U server chassis and the X7DBE+/X7DB8+ dual Intel Xeon processor serverboard. Please refer to our web site for information on operating systems that have been certified for use with the SuperServer 6025B-TR+/6025B-8R+ ([www.supermicro.com](http://www.supermicro.com)).

In addition to the serverboard and chassis, various hardware components have been included with the SuperServer 6025B-TR+/6025B-8R+, as listed below:

- Three (3) 8-cm hot-swap chassis fans (FAN-0070)
- One (1) air shroud (MCP-310-00005-00)
- Two (2) CPU passive heatsinks (SNK-P0018)
- One (1) DVD-ROM drive (DVM-PNSC-824)
- Two (2) 3.5" dummy drive trays
- One (1) ATA66 cable for DVD drive (CBL-0139L)
- One (1) floppy cable (CBL-040L)
- One (1) front control panel cable (CBL-0087)
- One (1) rail set (MCP-290-00002-00)
- SCSI Accessories (6025B-8R+ only)
  - One (1) dual-channel SCSI backplane (BPN-SCA-825S2)
  - One (1) Ultra320 SCSI ribbon cable (CBL-037L-U320)
  - One (1) Ultra320 SCSI round cable (CBL-0043L)
  - Eight (8) SCSI hot-swap drive carriers [MCP-220-00001-03(01)]\*

List continued on next page.

- SATA Accessories (6025B-TR+ only)
  - One (1) SATA backplane (BPN-SAS-825TQ)
  - Six (6) SATA cables (CBL-0061L)
  - Two (2) SATA LED cables (CBL-0157L)
  - Eight (8) SATA hot-swap drive carriers [MCP-220-00001-03(01)]\*  
(The chassis has eight carriers but only six SATA drives are supported.)

\*The 6025B-TR+/6025B-8R+ is available in silver and black; "03" following a part number indicates silver and "01" indicates black.

## 1-2 Serverboard Features

At the heart of the SuperServer 6025B-TR+/6025B-8R+ lies the X7DBE+/X7DB8+, a dual processor serverboard based on the Intel 5000P chipset and designed to provide maximum performance. Below are the main features of the X7DBE+/X7DB8+. (See Figure 1-1 for a block diagram of the 5000P chipset).

### Processors

The X7DBE+/X7DB8+ supports single or dual LGA 771 type Intel Xeon processors at a FSB speed of 1333 MHz. Please refer to the serverboard description pages on our web site for a complete listing of supported processors ([www.supermicro.com](http://www.supermicro.com)).

### Memory

The X7DBE+/X7DB8+ has sixteen 240-pin DIMM slots that can support up to 64 GB of FBD (Fully Buffered DIMM) ECC DDR2-667/533 SDRAM. Memory slots should be populated with modules of the same size and speed. See Chapter 5 Section 5 for details.

### Onboard SCSI (6025B-8R+ only)

An onboard Adaptec AIC-7902 dual-channel SCSI controller is integrated into the X7DB8+, which supports eight 80-pin SCA Ultra320 SCSI hard drives. The SCSI drives are connected to an SCA backplane that provides power, bus termination and configuration settings. The SCSI drives are hot-swappable units.

**Note:** The operating system you use must have RAID support to enable the hot-swap capability and RAID function of the SCSI drives.

## Serial ATA

A SATA controller is integrated into the South Bridge of the 5000P chipset to provide a six-port Serial ATA subsystem, which is RAID 0, 1, 10 and 5 supported. The Serial ATA drives are hot-swappable units.

**Note:** The operating system you use must have RAID support to enable the hot-swap capability and RAID function of the Serial ATA drives.

## PCI Expansion Slots

The X7DBE+/X7DB8+ has six PCI expansion slots, which includes two x8 PCI-Express slots, one x4 PCI-Express slot, two 64-bit 133 MHz PCI-X slots and one 64-bit 100 MHz PCI-X slot. (On the X7DB8+, one 100 MHz PCI slot supports Zero Channel RAID.)

## Onboard Controllers/Ports

One floppy drive controller and two onboard ATA/100 controllers are provided to support up to four IDE hard drives or ATAPI devices. The color-coded I/O ports include one COM port (an additional COM header is located on the serverboard), a VGA (monitor) port, a parallel port, two USB 2.0 ports, PS/2 mouse and keyboard ports and two gigabit Ethernet ports.

## ATI Graphics Controller

The X7DBE+/X7DB8+ features an integrated ATI video controller based on the ES1000 graphics chip. The ES1000 was designed specifically for servers, featuring low power consumption, high reliability and superior longevity.

## Other Features

Other onboard features that promote system health include onboard voltage monitors, a chassis intrusion header, auto-switching voltage regulators, chassis and CPU overheat sensors, virus protection and BIOS rescue.

## 1-3 Server Chassis Features

The following is a general outline of the main features of the SC825TQ-R700LP/SC825S2-R700LP server chassis.

### System Power

The SC825TQ-R700LP/SC825S2-R700LP features a redundant 700W power supply composed of two separate power modules. This power redundancy feature allows you to replace a failed power supply without shutting down the system.

### SCSI Subsystem (6025B-8R+ only)

The SC825S2-R700LP chassis was designed to support eight dual-channel SCSI hard drives, which are hot-swappable units.

**Note:** The operating system you use must have RAID support to enable the hot-swap capability of the SCSI drives.

### Serial ATA Subsystem

The SC825TQ-R700LP supports up to eight 3 Gb/s Serial ATA drives. The Serial ATA drives are hot-swappable units and are connected to a backplane that provides power and control.

**Note:** The operating system you use must have RAID support to enable the hot-swap capability of the Serial ATA drives.

### Front Control Panel

The control panel on the SuperServer 6025B-TR+/6025B-8R+ provides you with system monitoring and control. LEDs indicate system power, HDD activity, network activity, system overheat and power supply failure. A main power button and a system reset button are also included. In addition, two USB ports have been incorporated into the control panel to provide front side USB access.

### I/O Backplane

The SC825TQ-R700LP/SC825S2-R700LP is an ATX form factor chassis designed to be used in a 2U rackmount configuration. The I/O backplane provides seven low-profile PCI expansion slots, one COM port, a parallel port, a VGA port, two USB 2.0 ports, PS/2 mouse and keyboard ports and two gigabit Ethernet ports.

---

## Cooling System

The SC825TQ-R700LP/SC825S2-R700LP chassis has an innovative cooling design that includes three 8-cm hot-plug system cooling fans located in the middle section of the chassis. An air shroud channels the airflow from the system fans to efficiently cool the processor area of the system. The power supply module also includes a cooling fan.

**Figure 1-1. Intel 5000P/ESB2 Chipset:  
System Block Diagram**

Note: This is a general block diagram. Please see Chapter 5 for details.

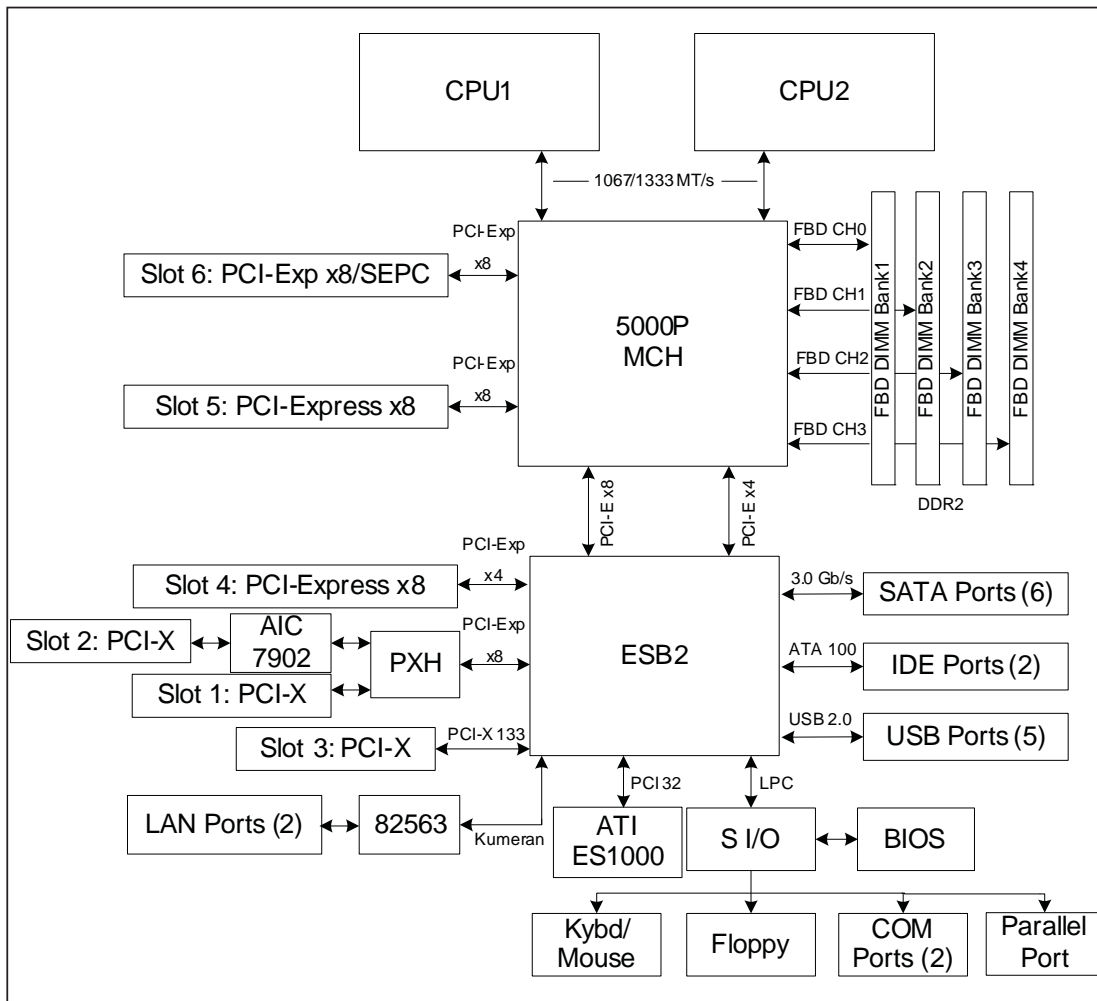

**Note:** The AIC-7902 SCSI controller is only on the X7DB8+ serverboard.

## 1-4 Contacting Supermicro

### Headquarters

Address: Super Micro Computer, Inc.  
980 Rock Ave.  
San Jose, CA 95131 U.S.A.

Tel: +1 (408) 503-8000

Fax: +1 (408) 503-8008

Email: [marketing@supermicro.com](mailto:marketing@supermicro.com) (General Information)  
[support@supermicro.com](mailto:support@supermicro.com) (Technical Support)

Web Site: [www.supermicro.com](http://www.supermicro.com)

### Europe

Address: Super Micro Computer B.V.  
Het Sterrenbeeld 28, 5215 ML  
's-Hertogenbosch, The Netherlands

Tel: +31 (0) 73-6400390

Fax: +31 (0) 73-6416525

Email: [sales@supermicro.nl](mailto:sales@supermicro.nl) (General Information)  
[support@supermicro.nl](mailto:support@supermicro.nl) (Technical Support)  
[rma@supermicro.nl](mailto:rma@supermicro.nl) (Customer Support)

### Asia-Pacific

Address: Super Micro Computer, Inc.  
4F, No. 232-1, Liancheng Rd.  
Chung-Ho 235, Taipei County  
Taiwan, R.O.C.

Tel: +886-(2) 8226-3990

Fax: +886-(2) 8226-3991

Web Site: [www.supermicro.com.tw](http://www.supermicro.com.tw)

Technical Support:

Email: [support@supermicro.com.tw](mailto:support@supermicro.com.tw)

Tel: 886-2-8228-1366, ext.132 or 139

# Chapter 2

## Server Installation

### 2-1 Overview

This chapter provides a quick setup checklist to get your SuperServer 6025B-TR+/6025B-8R+ up and running. Following these steps in the order given should enable you to have the system operational within a minimum amount of time. This quick setup assumes that your system has come to you with the processors and memory preinstalled. If your system is not already fully integrated with a serverboard, processors, system memory etc., please turn to the chapter or section noted in each step for details on installing specific components.

### 2-2 Unpacking the System

You should inspect the box the SuperServer 6025B-TR+/6025B-8R+ was shipped in and note if it was damaged in any way. If the server itself shows damage you should file a damage claim with the carrier who delivered it.

Decide on a suitable location for the rack unit that will hold the SuperServer 6025B-TR+/6025B-8R+. It should be situated in a clean, dust-free area that is well ventilated. Avoid areas where heat, electrical noise and electromagnetic fields are generated. You will also need it placed near a grounded power outlet. Read the Rack and Server Precautions in the next section.

### 2-3 Preparing for Setup

The box the SuperServer 6025B-TR+/6025B-8R+ was shipped in should include two sets of rail assemblies, two rail mounting brackets and the mounting screws you will need to install the system into the rack. Follow the steps in the order given to complete the installation process in a minimum amount of time. Please read this section in its entirety before you begin the installation procedure outlined in the sections that follow.

## Choosing a Setup Location

- Leave enough clearance in front of the rack to enable you to open the front door completely (~25 inches).
- Leave approximately 30 inches of clearance in the back of the rack to allow for sufficient airflow and ease in servicing.
- This product is for installation only in a Restricted Access Location (dedicated equipment rooms, service closets and the like).
- This product is not suitable for use with visual display work place devices according to §2 of the the German Ordinance for Work with Visual Display Units.



### Warnings and Precautions!



## Rack Precautions

- Ensure that the leveling jacks on the bottom of the rack are fully extended to the floor with the full weight of the rack resting on them.
- In single rack installation, stabilizers should be attached to the rack.
- In multiple rack installations, the racks should be coupled together.
- Always make sure the rack is stable before extending a component from the rack.
- You should extend only one component at a time - extending two or more simultaneously may cause the rack to become unstable.

## Server Precautions

- Review the electrical and general safety precautions in Chapter 4.
- Determine the placement of each component in the rack *before* you install the rails.
- Install the heaviest server components on the bottom of the rack first, and then work up.
- Use a regulating uninterruptible power supply (UPS) to protect the server from power surges, voltage spikes and to keep your system operating in case of a power failure.
- Allow the hot plug SATA/SCSI drives and power supply units to cool before touching them.
- Always keep the rack's front door and all panels and components on the servers closed when not servicing to maintain proper cooling.

## **Rack Mounting Considerations**

### **Ambient Operating Temperature**

If installed in a closed or multi-unit rack assembly, the ambient operating temperature of the rack environment may be greater than the ambient temperature of the room. Therefore, consideration should be given to installing the equipment in an environment compatible with the manufacturer's maximum rated ambient temperature ( $T_{mra}$ ).

### **Reduced Airflow**

Equipment should be mounted into a rack so that the amount of airflow required for safe operation is not compromised.

### **Mechanical Loading**

Equipment should be mounted into a rack so that a hazardous condition does not arise due to uneven mechanical loading.

### **Circuit Overloading**

Consideration should be given to the connection of the equipment to the power supply circuitry and the effect that any possible overloading of circuits might have on overcurrent protection and power supply wiring. Appropriate consideration of equipment nameplate ratings should be used when addressing this concern.

### **Reliable Ground**

A reliable ground must be maintained at all times. To ensure this, the rack itself should be grounded. Particular attention should be given to power supply connections other than the direct connections to the branch circuit (i.e. the use of power strips, etc.).

## 2-4 Installing the System into a Rack

This section provides information on installing the SuperServer 6025B-TR+/6025B-8R+ into a rack unit. If the 6025B-TR+/6025B-8R+ has already been mounted into a rack, you can skip ahead to Sections 2-5 and 2-6. There are a variety of rack units on the market, which may mean the assembly procedure will differ slightly. The following is a guideline for installing the system into a rack with the rack rails provided. You should also refer to the installation instructions that came with the rack unit you are using.

### Identifying the Sections of the Rack Rails

You should have received a total of six rack rail sections with the SuperServer 6025B-TR+/6025B-8R+. Two of these sections secure directly to the 6025B-TR+/6025B-8R+ and the third (which actually consists of two joined sections) secures directly to the rack itself. All screws and hardware mentioned in the installation steps should be included in the hardware kit.

Refer to Figure 2-1 to determine which rail section gets attached to the front of the chassis and which gets attached to the rear of the chassis. (The longer of the two is the front section. The third rail section attaches to the rack.)

### Installing the Chassis Rails

Position the front and rear chassis rail sections along the side of the 6025B-TR+/6025B-8R+ making sure the screw holes line up. Note that these two rails are left/right specific. Screw the front chassis rail (the long piece) securely to the side of the chassis (see Figure 2-1, step 1). There should be two screws for each side. Repeat this procedure for the other rail on the opposite side of the chassis. Then attach the two rear chassis rails to the chassis in the same manner, again keeping in mind that the rails are left/right specific. (You will also need to attach the rail brackets when installing into a telco rack.)

**Locking Tabs:** Both front chassis rails and the rack rails have a locking tab, which serves two functions. The first is to lock the server into place when installed and pushed fully into the rack, which is its normal position. Secondly, these tabs also lock the server in place when fully extended from the rack. This prevents the server from coming completely out of the rack when you pull it out for servicing.

Figure 2-1. Installing Chassis Rails

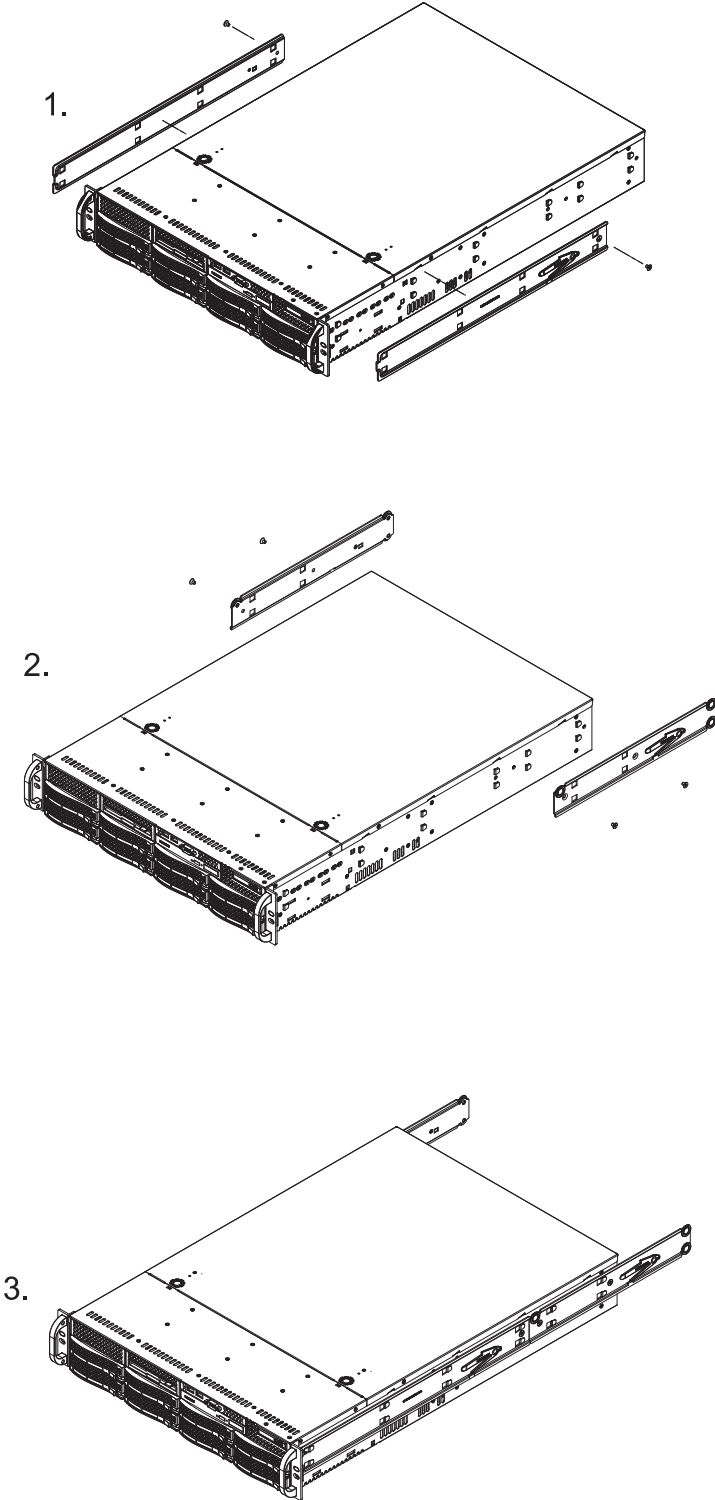

## **Installing the Rack Rails:**

Determine where you want to place the SuperServer 6025B-TR+/6025B-8R+ in the rack. (See Rack and Server Precautions in Section 2-3.) Position the fixed rack rail/sliding rail guide assemblies (made up of two inter-locking sections) at the desired location in the rack, keeping the sliding rail guide facing the inside of the rack and the rollers toward the front of the rack. Screw the assembly securely to the rack. Attach the other assembly to the other side of the rack, making sure both are at the exact same height and with the rail guides facing inward.

## **Installing the Server into the Rack**

You should now have rails attached to both the chassis and the rack unit. The next step is to install the server into the rack. Do this by lining up the rear of the chassis rails with the front of the rack rails. Slide the chassis rails into the rack rails, keeping the pressure even on both sides (you may have to depress the locking tabs when inserting). See Figure 2-2.

When the server has been pushed completely into the rack, you should hear the locking tabs "click". Finish by inserting and tightening the thumbscrews that hold the front of the server to the rack.

## **Installing the Server into a Telco Rack**

To install the SuperServer 6025B-TR+/6025B-8R+ into a Telco type rack, use two L-shaped brackets on either side of the chassis (four total). First, determine how far the server will extend out the front of the rack. Larger chassis should be positioned to balance the weight between front and back. If a bezel is included on your server, remove it. Then attach the two front brackets to each side of the chassis, then the two rear brackets positioned with just enough space to accommodate the width of the rack. Finish by sliding the chassis into the rack and tightening the brackets to the rack.

Figure 2-2. Installing the Server into a Rack

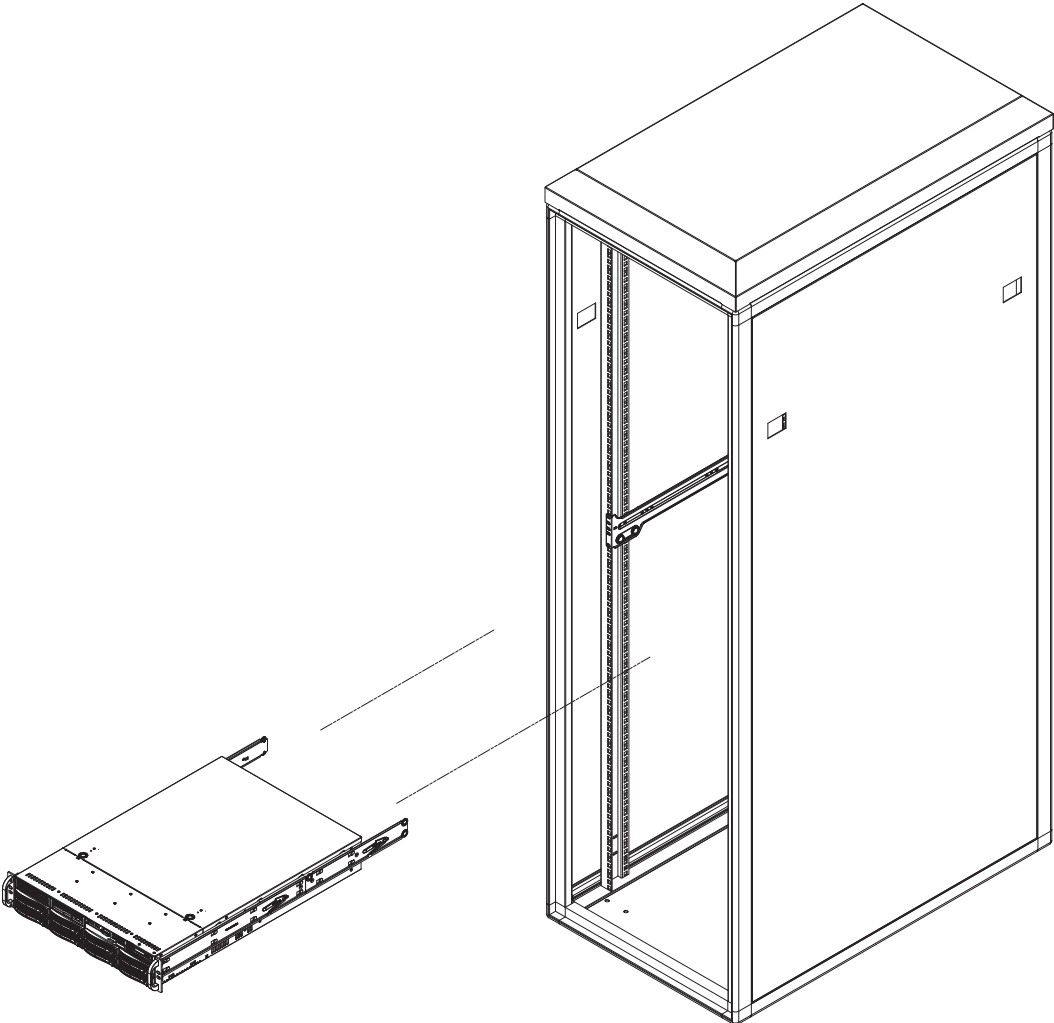

## 2-5 Checking the Serverboard Setup

After you install the 6025B-TR+/6025B-8R+ in the rack, you will need to open the unit to make sure the serverboard is properly installed and all the connections have been made.

### 1. Accessing the inside of the System (see Figure 2-3)

First, grasp the two handles on either side and pull the unit straight out until it locks (you will hear a "click"). Next, depress the two buttons on the top of the chassis to release the top cover. You can then lift the top cover from the chassis to gain full access to the inside of the server.

### 2. Check the CPUs (processors)

You may have one or two processors already installed into the serverboard. Each processor needs its own heatsink. See Chapter 5 for instructions on processor and heatsink installation.

### 3. Check the system memory

Your 6025B-TR+/6025B-8R+ server system may have come with system memory already installed. Make sure all DIMMs are fully seated in their slots. For details on adding system memory, refer to Chapter 5.

### 4. Installing add-on cards

If desired, you can install add-on cards to the system. See Chapter 5 for details on installing PCI add-on cards.

### 5. Check all cable connections and airflow

Make sure all power and data cables are properly connected and not blocking the chassis airflow. Also make sure that no cables are positioned in front of the fans. See Chapter 5 for details on cable connections.

Figure 2-3. Accessing the Inside of the System

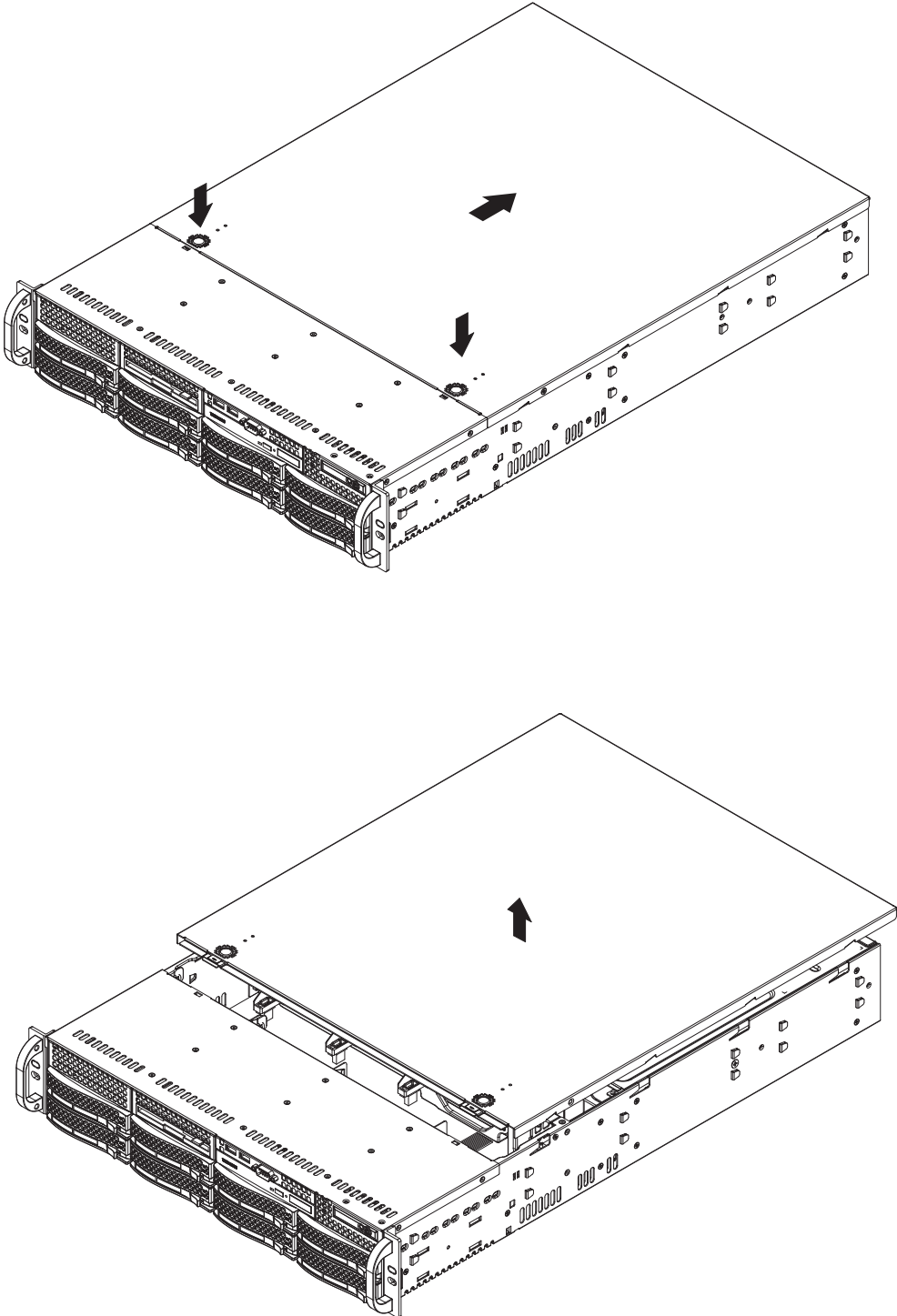

## 2-6 Checking the Drive Bay Setup

Next, you should check to make sure the peripheral drives and the Serial ATA drives have been properly installed and all connections have been made.

### 1. Accessing the drive bays

All drives are accessible from the front of the server. For servicing the DVD-ROM and floppy drives, you will need to remove the top chassis cover. The Serial ATA disk drives can be installed and removed from the front of the chassis without removing the top chassis cover.

### 2. DVD-ROM and floppy disk drives

A slim DVD-ROM and a floppy drive should be preinstalled in your server. Refer to Chapter 6 if you need to reinstall a DVD-ROM and/or floppy disk drive to the system.

### 3. Check the SATA/SCSI drives

Depending upon your system's configuration, your system may have one or more drives already installed. If you need to install SATA/SCSI drives, please refer to Chapter 6.

### 4. Check the airflow

Airflow is provided by four 8-cm center chassis cooling fans. An air shroud is also included in the system to maximize airflow. The system component layout was carefully designed to direct sufficient cooling airflow to the components that generate the most heat. Note that all power and data cables have been routed in such a way that they do not block the airflow generated by the fans.

### 5. Supplying power to the system

The last thing you must do is to provide input power to the system. Plug the power cord(s) from the power supply unit(s) into a high-quality power strip that offers protection from electrical noise and power surges. It is recommended that you use an uninterruptible power supply (UPS).

# Chapter 3

## System Interface

### 3-1 Overview

There are several LEDs on the control panel as well as others on the Serial ATA drive carriers to keep you constantly informed of the overall status of the system as well as the activity and health of specific components. There are also two buttons on the chassis control panel.

### 3-2 Control Panel Buttons

The two push-buttons located on the front of the chassis are (in order from left to right) a reset button and a power on/off button.

#### RESET

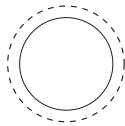

- **RESET:** Use the reset button to reboot the system.



- **POWER:** This is the main power button, which is used to apply or turn off the main system power. Turning off system power with this button removes the main power but keeps standby power supplied to the system.

### 3-3 Control Panel LEDs

The control panel located on the front of the chassis has several LEDs. These LEDs provide you with critical information related to different parts of the system. This section explains what each LED indicates when illuminated and any corrective action you may need to take.



- **Power Fail:** Indicates a power supply module has failed. The second power supply module will take the load and keep the system running but the failed module will need to be replaced. Refer to Chapter 6 for details on replacing the power supply. This LED should be off when the system is operating normally.



- **Overheat/Fan Fail:** When this LED flashes, it indicates a fan failure. When on continuously it indicates an overheat condition, which may be caused by cables obstructing the airflow in the system or the ambient room temperature being too warm. Check the routing of the cables and make sure all fans are present and operating normally. You should also check to make sure that the chassis covers are installed. Finally, verify that the heatsinks are installed properly (see Chapter 5). This LED will remain flashing or on as long as the indicated condition exists.



- **NIC1:** Indicates network activity on the JLAN1 port when flashing.



- **NIC2:** Indicates network activity on the JLAN2 port when flashing.



- **HDD:** Indicates IDE channel activity. On the SuperServer 6025B-TR+/6025B-8R+, this LED indicates SATA/SCSI and/or DVD-ROM drive activity when flashing.



- **Power:** Indicates power is being supplied to the system's power supply units. This LED should normally be illuminated when the system is operating.

## 3-4 Drive Carrier LEDs

### SATA Drives (6025B-TR+)

- **Green:** Each Serial ATA drive carrier has a green LED. When illuminated, this green LED (on the front of the SATA drive carrier) indicates drive activity. A connection to the SATA backplane enables this LED to blink on and off when that particular drive is being accessed. Please refer to Chapter 6 for instructions on replacing failed SATA drives.
- **Red:** The red LED to indicate an SATA drive failure. If one of the SATA drives fail, you should be notified by your system management software. Please refer to Chapter 6 for instructions on replacing failed SATA drives.

### SCSI Drives (6025B-8R+)

Each SCSI drive carrier has two LEDs.

- **Green:** When illuminated, the green LED on the front of the SCSI drive carrier indicates drive activity. A connection to the SCSI SCA backplane enables this LED to blink on and off when that particular drive is being accessed.
- **Red:** The SAF-TE compliant backplane activates the red LED to indicate a drive failure. If one of the SCSI drives fail, you should be notified by your system management software. Please refer to Chapter 6 for instructions on replacing failed SCSI drives.

# Notes

# Chapter 4

## System Safety

### 4-1 Electrical Safety Precautions



Basic electrical safety precautions should be followed to protect yourself from harm and the SuperServer 6025B-TR+/6025B-8R+ from damage:

- Be aware of the locations of the power on/off switch on the chassis as well as the room's emergency power-off switch, disconnection switch or electrical outlet. If an electrical accident occurs, you can then quickly remove power from the system.
- Do not work alone when working with high voltage components.
- Power should always be disconnected from the system when removing or installing main system components, such as the serverboard, memory modules and the DVD-ROM and floppy drives. When disconnecting power, you should first power down the system with the operating system and then unplug the power cords of all the power supply units in the system.
- When working around exposed electrical circuits, another person who is familiar with the power-off controls should be nearby to switch off the power if necessary.
- Use only one hand when working with powered-on electrical equipment. This is to avoid making a complete circuit, which will cause electrical shock. Use extreme caution when using metal tools, which can easily damage any electrical components or circuit boards they come into contact with.
- Do not use mats designed to decrease electrostatic discharge as protection from electrical shock. Instead, use rubber mats that have been specifically designed as electrical insulators.

- The power supply power cord must include a grounding plug and must be plugged into grounded electrical outlets.
- Serverboard Battery: **CAUTION** - There is a danger of explosion if the onboard battery is installed upside down, which will reverse its polarities (see Figure 4-1). This battery must be replaced only with the same or an equivalent type recommended by the manufacturer. Dispose of used batteries according to the manufacturer's instructions.
- DVD-ROM Laser: **CAUTION** - this server may have come equipped with a DVD-ROM drive. To prevent direct exposure to the laser beam and hazardous radiation exposure, do not open the enclosure or use the unit in any unconventional way.
- Mainboard replaceable soldered-in fuses: Self-resetting PTC (Positive Temperature Coefficient) fuses on the mainboard must be replaced by trained service technicians only. The new fuse must be the same or equivalent as the one replaced. Contact technical support for details and support.

## 4-2 General Safety Precautions



Follow these rules to ensure general safety:

- Keep the area around the SuperServer 6025B-TR+/6025B-8R+ clean and free of clutter.
- The SuperServer 6025B-TR+/6025B-8R+ weighs approximately 57 lbs (25.9 kg.) when fully loaded. When lifting the system, two people at either end should lift slowly with their feet spread out to distribute the weight. Always keep your back straight and lift with your legs. Don't use the handles (if installed) to lift the chassis; the handles should only be used to pull the server out of the rack.
- Place the chassis top cover and any system components that have been removed away from the system or on a table so that they won't accidentally be stepped on.
- While working on the system, do not wear loose clothing such as neckties and unbuttoned shirt sleeves, which can come into contact with electrical circuits

or be pulled into a cooling fan.

- Remove any jewelry or metal objects from your body, which are excellent metal conductors that can create short circuits and harm you if they come into contact with printed circuit boards or areas where power is present.
- After accessing the inside of the system, close the system back up and secure it to the rack unit with the retention screws after ensuring that all connections have been made.

### 4-3 ESD Precautions



Electrostatic discharge (ESD) is generated by two objects with different electrical charges coming into contact with each other. An electrical discharge is created to neutralize this difference, which can damage electronic components and printed circuit boards. The following measures are generally sufficient to neutralize this difference before contact is made to protect your equipment from ESD:

- Use a grounded wrist strap designed to prevent static discharge.
- Keep all components and printed circuit boards (PCBs) in their antistatic bags until ready for use.
- Touch a grounded metal object before removing the board from the antistatic bag.
- Do not let components or PCBs come into contact with your clothing, which may retain a charge even if you are wearing a wrist strap.
- Handle a board by its edges only; do not touch its components, peripheral chips, memory modules or contacts.
- When handling chips or modules, avoid touching their pins.
- Put the serverboard and peripherals back into their antistatic bags when not in use.

- For grounding purposes, make sure your computer chassis provides excellent conductivity between the power supply, the case, the mounting fasteners and the serverboard.

## 4-4 Operating Precautions



Care must be taken to assure that the chassis cover is in place when the 6025B-TR+/6025B-8R+ is operating to assure proper cooling. Out of warranty damage to the 6025B-TR+/6025B-8R+ system can occur if this practice is not strictly followed.

**Figure 4-1. Installing the Onboard Battery**

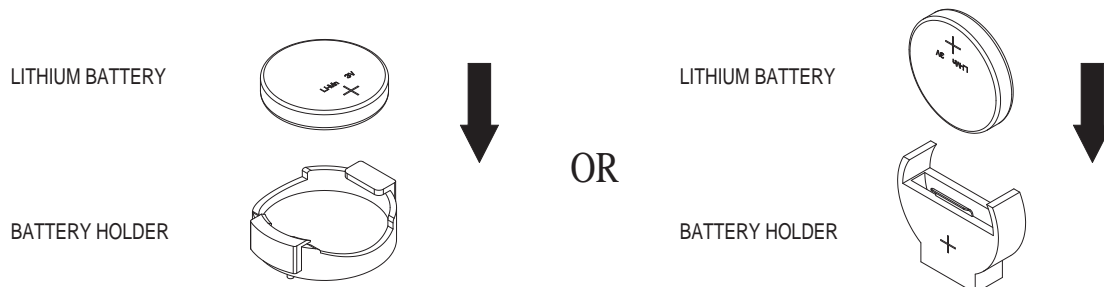

## Chapter 5

# Advanced Serverboard Setup

This chapter covers the steps required to install processors and heatsinks to the X7DBE+/X7DB8+ serverboard, connect the data and power cables and install add-on cards. All serverboard jumpers and connections are described and a layout and quick reference chart are included in this chapter. Remember to close the chassis completely when you have finished working on the serverboard to protect and cool the system sufficiently.

### 5-1 Handling the Serverboard

Static electrical discharge can damage electronic components. To prevent damage to printed circuit boards, it is important to handle them very carefully (see Chapter 4). Also note that the size and weight of the serverboard can cause it to bend if handled improperly, which may result in damage. To prevent the serverboard from bending, keep one hand under the center of the board to support it when handling. The following measures are generally sufficient to protect your equipment from static discharge.

#### Precautions

- Use a grounded wrist strap designed to prevent static discharge.
- Touch a grounded metal object before removing any board from its antistatic bag.
- Handle a board by its edges only; do not touch its components, peripheral chips, memory modules or gold contacts.
- When handling chips or modules, avoid touching their pins.
- Put the serverboard, add-on cards and peripherals back into their antistatic bags when not in use.

#### Unpacking

The serverboard is shipped in antistatic packaging to avoid static damage. When unpacking the board, make sure the person handling it is static protected.

## 5-2 Processor and Heatsink Installation



When handling the processor, avoid placing direct pressure on the label area of the fan. Also, do not place the serverboard on a conductive surface, which can damage the BIOS battery and prevent the system from booting up.

**IMPORTANT:** Always connect the power cord last and remove it first before adding, removing or changing any hardware components. Make sure that you install the processor into the CPU socket *before* you install the heatsink and fan. The X7DBE+/X7DB8+ can support either one or two Xeon LGA 771 processors. If installing one processor only, install it into CPU socket #1.

### Notes:

1. Intel's boxed Xeon CPU package contains a CPU fan and heatsink assembly. If you buy a CPU separately, make sure that you use only Intel-certified multi-directional heatsinks and fans.
2. When purchasing an LGA 771 CPU or when receiving a serverboard with an LGA 771 CPU pre-installed, make sure that the CPU plastic cap is in place and none of the CPU pins are bent; otherwise, contact the retailer immediately.
3. Revision 2.0 and above of the X7DBE+/X7DB8+ will also support "Woodcrest" CPUs.

### Installing the LGA 771 Processor

1. A black PnP cap is attached to the load plate to protect the CPU socket. Press the load lever down and away from the retention clasp to release the load plate from its locked position.

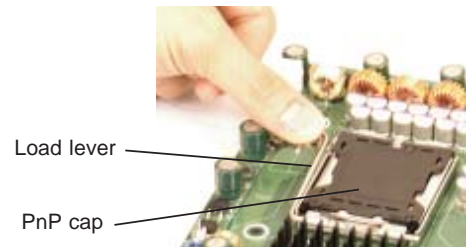

2. Gently lift the load lever to open the load plate.

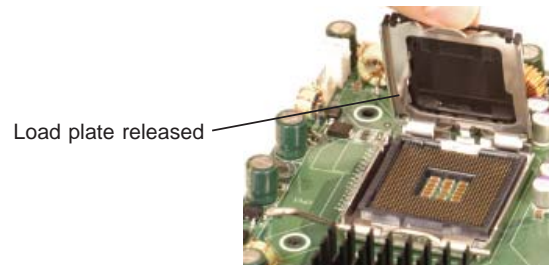

3. Use your thumb and your index finger to hold the CPU at opposite sides.

4. Align pin1 of the CPU (the corner marked with a triangle) with the notched corner of the CPU socket.

5. Find the corner of the CPU that has a semi-circle cutout below a gold dot (CPU key). This corner should be aligned with the cutout on the socket (socket key).

6. Once aligned, carefully lower the CPU straight down into the socket. Do not drop the CPU on the socket, do not move the CPU horizontally or vertically and do not rub the CPU against any surface or any of the contacts, which may damage the CPU and/or contacts.

7. With the CPU in the socket, inspect the four corners of the CPU to make sure that it is properly installed.

8. Use your thumb to gently push the load lever down until it snaps into the retention clasp.

9. If the CPU is properly installed into the socket, the PnP cap will be automatically released from the load plate when the lever locks. Repeat steps to install a second CPU if desired.

**Warning!** Keep the plastic PnP cap. The serverboard must be shipped with the PnP cap properly installed to protect the CPU socket. Shipment without the PnP cap properly installed will void the warranty.

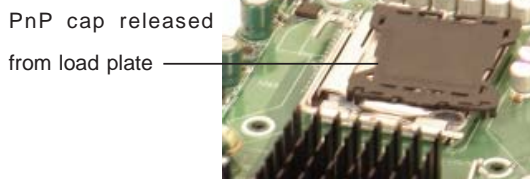
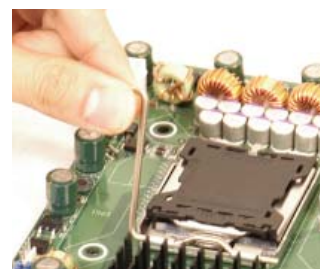
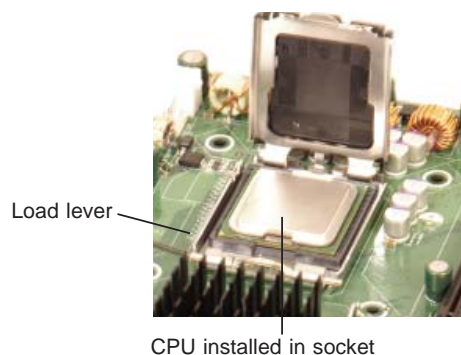
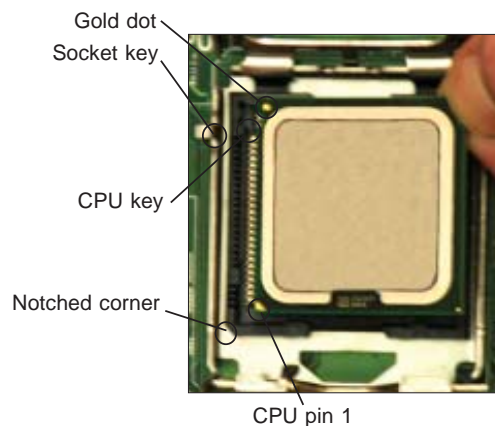

## Installing the Heatsink

1. Do not apply any thermal grease to the heatsink or the CPU die; the required amount has already been applied.
2. Place the heatsink on top of the CPU so that the four mounting holes are aligned with those on the (preinstalled) heatsink retention mechanism.
3. Screw in two diagonal screws (i.e. the #1 and the #2 screws) until just snug. Do not fully tighten the screws or you may damage the CPU.)
4. Add the two remaining screws then finish the installation by fully tightening all four screws.

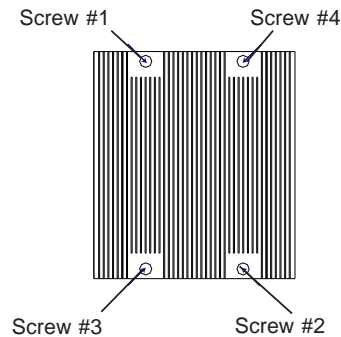
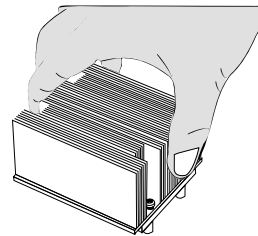
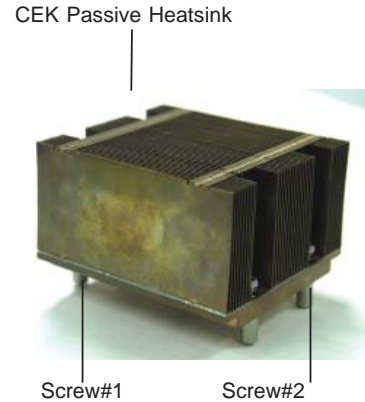

## Removing the Heatsink



**Warning!** We do not recommend removal of the heatsink. However, if you do need to uninstall the heatsink, please follow the instructions below to prevent damage to the CPU or the CPU socket.

1. Unscrew and remove the heatsink screws from the motherboard in the sequence as shown in the third diagram above.
2. Hold the heatsink as show in the second diagram above and gently wriggle the heatsink to loosen it from the CPU. (Do not use excessive force when wriggling the heatsink!!)
3. Once the heatsink is loose, remove it from the CPU.
4. Clean the surface of the CPU and the heatsink to get rid of the old thermal grease. Reapply the proper amount of thermal grease on the surface before you re-install the heatsink.

## 5-3 Connecting Cables

Now that the processors are installed, the next step is to connect the cables to the serverboard. These include the data (ribbon) cables for the peripherals and control panel and the power cables.

### Connecting Data Cables

The ribbon cables used to transfer data from the peripheral devices have been carefully routed in preconfigured systems to prevent them from blocking the flow of cooling air that moves through the system from front to back. If you need to disconnect any of these cables, you should take care to reroute them as they were originally after reconnecting them (make sure the red wires connect to the pin 1 locations). If you are configuring the system, keep the airflow in mind when routing the cables. The following data cables (with their serverboard connector locations noted) should be connected. See the serverboard layout diagram in this chapter for connector locations.

- DVD-ROM drive cable (IDE#1)
- 6025B-TR+: SATA cables (SATA0 ~ SATA5)
- 6025B-TR+: SATA Enclosure Management LED cables (SGPIO1, SGPIO2)
- 6025B-8R+: SCSI cables (JA1, JA2)
- Control Panel cable (JF1, see next page)

### Connecting Power Cables

The X7DBE+/X7DB8+ has a 24-pin primary power supply connector designated "JPW1" for connection to the ATX power supply. Connect the appropriate connector from the power supply to the "ATX Power" connector to supply power to the serverboard. See the Connector Definitions section in this chapter for power connector pin definitions.

In addition, your power supply must be connected to the 4-pin Secondary ATX Power connection at JPW2 and the 8-pin processor power connector at JPW3.

## Connecting the Control Panel

JF1 contains header pins for various front control panel connectors. See Figure 5-3 for the pin locations of the various front control panel buttons and LED indicators. Please note that even and odd numbered pins are on opposite sides of each header.

All JF1 wires have been bundled into single keyed ribbon cable to simplify their connection. The red wire in the ribbon cable plugs into pin 1 of JF1. Connect the other end of the cable to the Control Panel printed circuit board, located just behind the system status LEDs in the chassis.

See the Connector Definitions section in this chapter for details and pin descriptions of JF1.

**Figure 5-3. Front Control Panel Header Pins (JF1)**

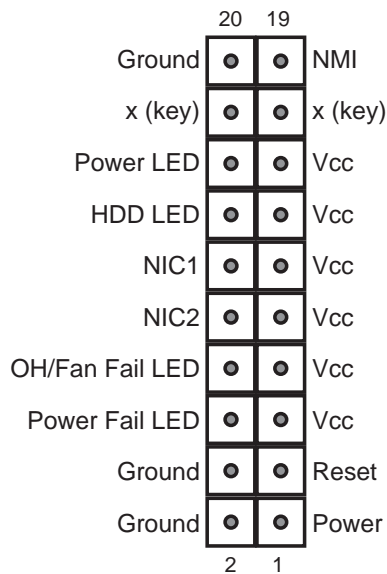

## 5-4 I/O Ports

The I/O ports are color coded in conformance with the PC 99 specification. See Figure 5-4 below for the colors and locations of the various I/O ports.

**Figure 5-4. Rear Panel I/O Ports**

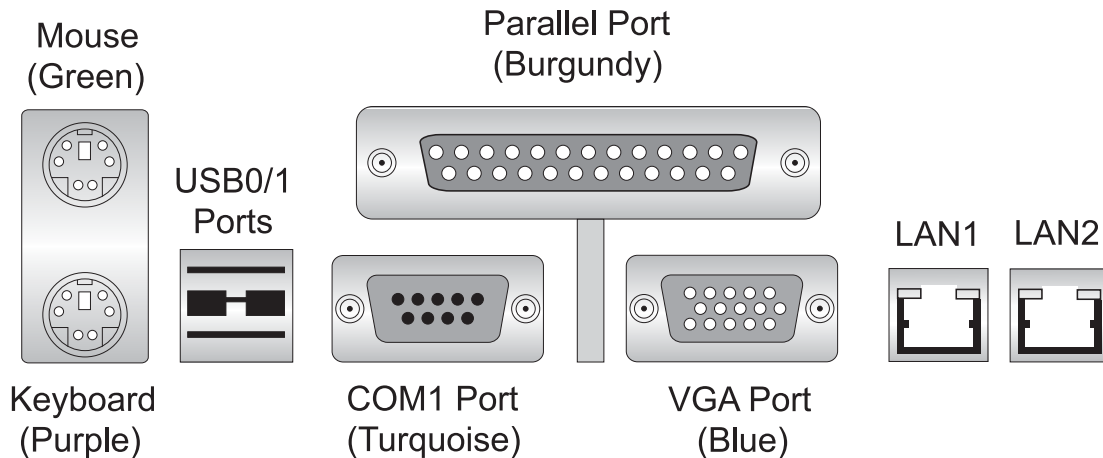

## 5-5 Installing Memory

**Note:** Check the Supermicro web site for recommended memory modules.

### **CAUTION!**

Exercise extreme care when installing or removing DIMM modules to prevent any possible damage. Also note that the memory is interleaved to improve performance (see step 1).

### **DIMM Installation (See Figure 5-5)**

1. Insert the desired number of DIMMs into the memory slots, starting with DIMM 1A. The memory scheme is interleaved so you must install two modules at a time, beginning with DIMM 1A and DIMM 2A and so on. (See the Memory Installation Table below.) Insert each DIMM module vertically into its slot. Pay attention to the notch along the bottom of the module to prevent inserting the DIMM module incorrectly.
2. Gently press down on the DIMM module until it snaps into place in the slot. Repeat for all modules (see step 1 above).

### Memory Support

The X7DBE+/X7DB8+ supports up to 64 GB of FBD (Fully Buffered DIMM) ECC DDR2-667/533. Populating with pairs of memory modules that are of the same size and same type will result in interleaved memory.

**Note:** Due to OS limitations, some operating systems may not show more than 4 GB of memory. To optimize memory support, follow the table below for memory installation:

Memory Installation Table																
Number of DIMMs	Branch 0								Branch 1							
	Bank 1 (Channel 0)				Bank 2 (Channel 1)				Bank 3 (Channel 2)				Bank 4 (Channel 3)			
2 DIMMs	1A	---	---	---	2A	---	---	---	---	---	---	---	---	---	---	---
4 DIMMs	1A	---	---	---	2A	---	---	---	3A	---	---	---	4A	---	---	---
8 DIMMs	1A	1B	---	---	2A	2B	---	---	3A	3B	---	---	4A	4B	---	---
12 DIMMs	1A	1B	1C	---	2A	2B	2C	---	3A	3B	3C	---	4A	4B	4C	---
16 DIMMs	1A	1B	1C	1D	2A	2B	2C	2D	3A	3B	3C	3D	4A	4B	4C	4D

**Notes:** i. DIMM slot# specified = DIMM slot to be populated; “---” = DIMM slot not to be populated. ii. Both FBD 533 MHz and 667MHz DIMMs are supported, however you need to use memory modules of the same speed and type. iii. Interleaving memory is supported when pairs of DIMM modules are installed in both Branch 0 and Branch 1. Interleaving memory is not available if only 2 DIMMs are installed. For memory to work properly, you need to follow the restrictions listed above. )

Figure 5-5. Installing DIMM into Slot

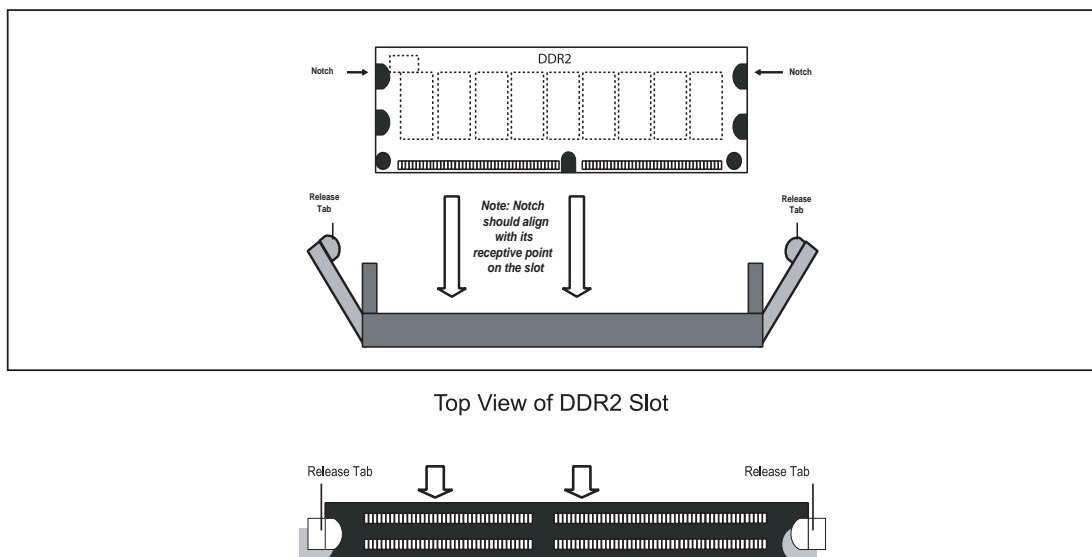

**To Install:** Insert module vertically and press down until it snaps into place. Pay attention to the bottom notches.

**To Remove:** Use your thumbs to gently push each release tab outward to free the DIMM from the slot.

## 5-6 Adding PCI Cards

### 1. PCI slots

The X7DBE+/X7DB8+ has six PCI expansion slots, which includes two x8 PCI-Express slots, one x4 PCI-Express slot, two 64-bit 133 MHz PCI-X slots and one 64-bit 100 MHz PCI-X slot. On the X7DB8+, the 100 MHz PCI-X slot supports Zero Channel RAID (ZCR).

### 2. PCI card installation

Before installing a PCI add-on card, make sure you install it into a slot that supports the speed of the card (see step 1, above). After gaining access to the inside of the server, determine which slot you wish to populate, then press down on the curved section at the top of the blue tab for that slot. While pressing down, lift the tab to unlock the shield. Insert the expansion card into the correct slot on the serverboard, pushing down with your thumbs evenly on both sides of the card. Lock the card into place by pressing down on the tab. Follow this procedure when adding a card to other slots.

## 5-7 Serverboard Details

**Figure 5-6. SUPER X7DB8+ Layout\***  
(not drawn to scale)

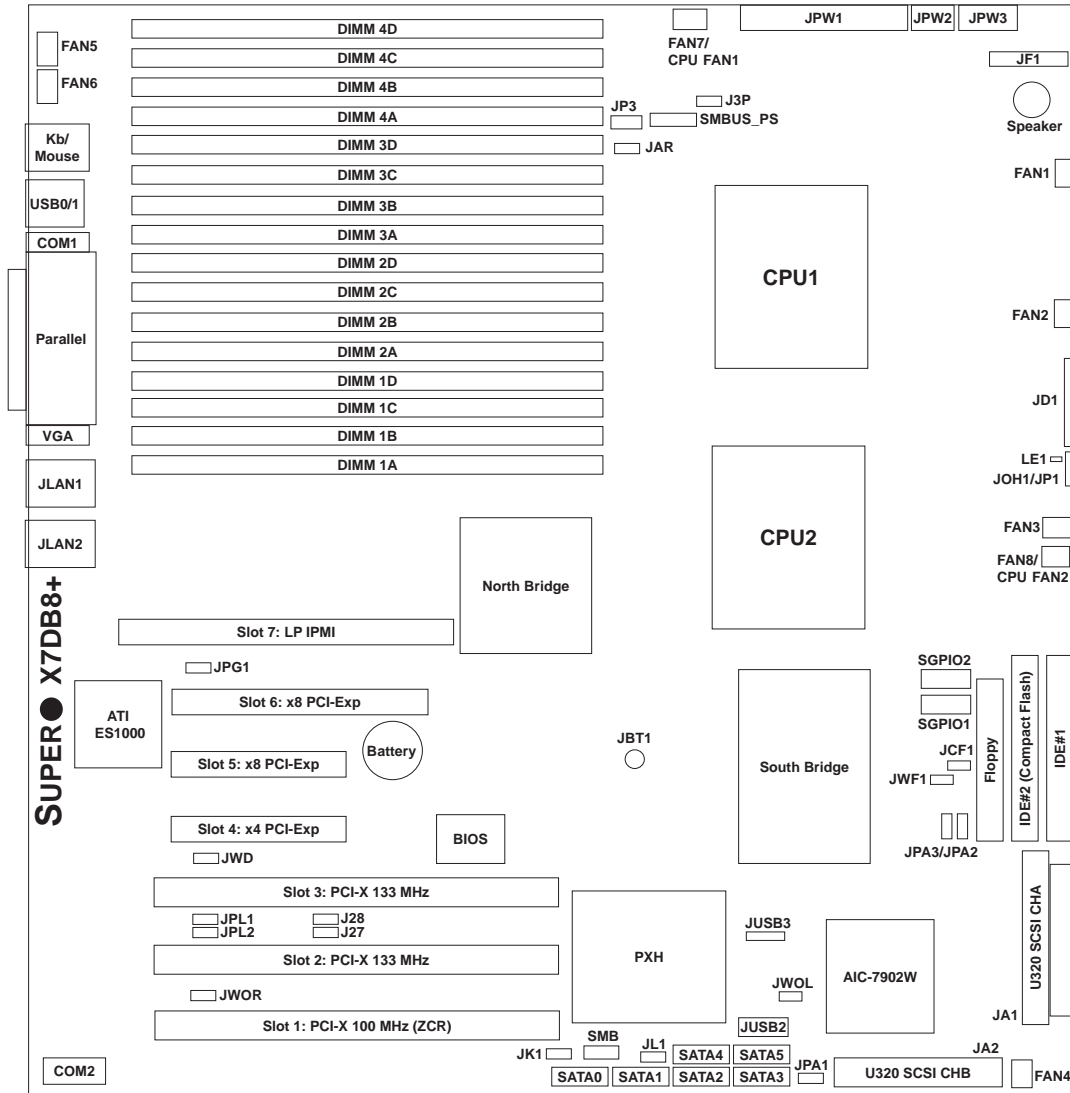

**\*Notes:**

Jumpers not noted are for test purposes only.

The X7DBE+ shares the same layout but without SCSI connectors, jumpers or components.

IDE#2 is for Compact Flash card use only. To use, close (enable) jumper JCF1 and connect the compact flash power to JWF1.

## X7DB8+X7DBE+ Quick Reference

<u>Jumper</u>	<u>Description</u>	<u>Default Setting</u>
J27/J28	SMBUS to PCI Enable/Disable	Closed (Enabled)
J3P	3rd Power Fail Detect	Open (Disabled)
JAR	Alarm Reset	Open (Disabled)
JBT1	CMOS Clear	(See Section 5-9)
JCF1	Compact Flash Master/Slave Select	Closed (Master)
JPA1*	SCSI Controller Enable/Disable	Pins 1-2 (Enabled)
JPA2/JPA3*	SCSI ChA/ChB Termination En/Dis	Open (Enabled)
JPG1	VGA Enable/Disable	Pins 1-2 (Enabled)
JPL1/JPL2	JLAN1/JLAN2 Enable/Disable	Pins 1-2 (Enabled)
JWD	Watch Dog	Pins 1-2 (Reset)

<u>Connector</u>	<u>Description</u>
COM1/COM2	COM1/COM2 Serial Port Connector/Header
FAN 1-8	Fans 1-8 (Fans 1-4 = 3-pin, Fans 5-8 = 4-pin)
Floppy	Floppy Disk Drive Connector
IDE#1/IDE#2*	IDE Hard Drive/Compact Flash Card Connectors
JA1/JA2*	SCSI Channel A & B Connectors
JD1	Power LED (pins1-3)/Speaker Header (pins 4-7)
JF1	Front Control Panel Connector
JK1	Keylock Header
JL1	Chassis Intrusion Header
JLAN1/2	G-bit Ethernet Ports
JOH1	Overheat LED
JP3	Power Fault header
JPW1	Primary 24-Pin ATX Power Connector
JPW2	Secondary Power Connector
JPW3	Processor Power Connector
JWF1	Compact Flash Card Power Connector
JWOL	Wake-on-LAN Header
JWOR	Wake-on-Ring Header
LE1	PWR LED Indicator
LP IPMI (Slot 7)	Low Profile IPMI Connector
Parallel	Parallel (Printer) Port
SATA0-SATA5	Intel Serial ATA Connectors
SGPIO1/SGPIO2	SGPIO Headers
SMB	System Management Bus Header
SMBUS_PS	Power System Management (I <sup>2</sup> C) Header
USB0/1, JUSB2, JUSB4	Back Panel USB0/1, Front Panel USB2/3, USB4

\*X7DB8+ only

## 5-8 Connector Definitions

### ATX Power Connector

The power supply connector meets the SSI (Superset ATX) 24-pin specification. Make sure that the orientation of the connector is correct. See the table on the right for pin definitions.

ATX Power 24-pin Connector Pin Definitions (JPW1)			
Pin#	Definition	Pin #	Definition
13	+3.3V	1	+3.3V
14	-12V	2	+3.3V
15	COM	3	COM
16	PS_ON	4	+5V
17	COM	5	COM
18	COM	6	+5V
19	COM	7	COM
20	Res (NC)	8	PWR_OK
21	+5V	9	5VSB
22	+5V	10	+12V
23	+5V	11	+12V
24	COM	12	+3.3V

### Secondary Power Connector

In addition to the Primary ATX power connector (above), the Secondary 12v 8-pin connector (JPW2) must also be connected to your power supply. See the table on the right for pin definitions.

+12V 4-pin Power Pin Definitions (JPW2)	
Pins	Definition
1 & 2	Ground
3 & 4	+12V

### Processor Power Connector

The JPW3 header must also be connected to the power supply to provide power for the processor(s). See the table on the right for pin definitions.

Processor Power Pin Definitions (JPW3)	
Pins	Definition
1 through 4	Ground
5 through 8	+12V

### NMI Button

The non-maskable interrupt button header is located on pins 19 and 20 of JF1. Refer to the table on the right for pin definitions.

NMI Button Pin Definitions (JF1)	
Pin#	Definition
19	Control
20	Ground

### Power LED

The Power LED connection is located on pins 15 and 16 of JF1. Refer to the table on the right for pin definitions.

Power LED Pin Definitions (JF1)	
Pin#	Definition
15	Vcc
16	Control

## HDD LED

The HDD (IDE Hard Disk Drive) LED connection is located on pins 13 and 14 of JF1. Attach the IDE hard drive LED cable to display disk activity. Refer to the table on the right for pin definitions.

HDD LED Pin Definitions (JF1)	
Pin#	Definition
13	Vcc
14	HD Active

## NIC1 LED

The NIC1 (Network Interface Controller) LED connection is located on pins 11 and 12 of JF1. Attach the NIC1 LED cable to display network activity. Refer to the table on the right for pin definitions.

NIC1 LED Pin Definitions (JF1)	
Pin#	Definition
11	Vcc
12	Ground

## NIC2 LED

The NIC2 (Network Interface Controller) LED connection is located on pins 9 and 10 of JF1. Attach the NIC2 LED cable to display network activity. Refer to the table on the right for pin definitions.

NIC2 LED Pin Definitions (JF1)	
Pin#	Definition
9	Vcc
10	Ground

## Overheat/Fan Fail LED (OH)

Connect an LED to the OH connection on pins 7 and 8 of JF1 to provide advanced warning of chassis overheating. Refer to the table on the right for pin definitions.

OH/Fan Fail LED Pin Definitions (JF1)	
Pin#	Definition
7	Vcc
8	Ground

## Power Fail LED

The Power Fail LED connection is located on pins 5 and 6 of JF1. Refer to the table on the right for pin definitions.

Power Fail LED Pin Definitions (JF1)	
Pin#	Definition
5	Vcc
6	Ground

## Reset Button

The Reset Button connection is located on pins 3 and 4 of JF1. Attach it to the hardware reset switch on the computer case. Refer to the table on the right for pin definitions.

Reset Button Pin Definitions (JF1)	
Pin#	Definition
3	Reset
4	Ground

## Power Button

The Power Button connection is located on pins 1 and 2 of JF1. Momentarily contacting both pins will power on/off the system. This button can also be configured to function as a suspend button (see the Power Button Mode setting in BIOS). To turn off the power when set to suspend mode, depress the button for at least 4 seconds. Refer to the table on the right for pin definitions.

Power Button Pin Definitions (JF1)	
Pin#	Definition
1	PW_ON
2	Ground

## Universal Serial Bus (USB0/1)

Two Universal Serial Bus ports are located beside the PS/2 keyboard/mouse ports. USB0 is the bottom connector and USB1 is the top connector. See the table on the right for pin definitions.

Universal Serial Bus Pin Definitions (USB0/1)			
USB0		USB1	
Pin #	Definition	Pin #	Definition
1	+5V	1	+5V
2	PO-	2	PO-
3	PO+	3	PO+
4	Ground	4	Ground
5	N/A	5	Key

## Chassis Intrusion

A Chassis Intrusion header is located at JL1. Attach the appropriate cable to inform you of a chassis intrusion.

Chassis Intrusion Pin Definitions (JL1)	
Pin#	Definition
1	Intrusion Input
2	Ground

## Serial Ports

The COM1 serial port is located beside the mouse port. COM2 is a header on the serverboard (see serverboard layout for location). See the table on the right for pin definitions.

Serial Port Pin Definitions (COM1/COM2)			
Pin #	Definition	Pin #	Definition
1	DCD	6	DSR
2	RXD	7	RTS
3	TXD	8	CTS
4	DTR	9	RI
5	Ground	10	NC

**Note:** Pin 10 is included on the header but not on the port. NC indicates no connection.

## Power Fail Header

Connect a cable from your power supply to the Power Fail header to provide you with warning of a power supply failure. The warning signal is passed through the PWR\_LED pin to indicate a power failure. See the table on the right for pin definitions.

Power Fail Header Pin Definitions (JP3)	
Pin#	Definition
1	P/S 1 Fail Signal
2	P/S 2 Fail Signal
3	P/S 3 Fail Signal
4	Reset Signal

**Note:** This feature is only available when using redundant Supermicro power supplies.

## Fan Headers

The X7DBE+/X7DB8+ has eight fan headers, designated Fan1 through Fan8. Fan speed is controlled via Thermal Management with a BIOS setting. See the table on the right for pin definitions.

Fan Header Pin Definitions (Fan1-8)	
Pin#	Definition
1	Ground (Black)
2	+12V (Red)
3	Tachometer
4	PWM Control

**Note:** Fan1-4 are 3-pin fans and Fan5-8 are 4-pin fans. Pins 1-3 of the 4-pin fan headers are backward compatible with traditional 3-pin fans. When using a Thermal Management setting, use all 3-pin fans or all 4-pin fans on the serverboard. Do not use 3-pin fans and 4-pin fans together.

## Extra Universal Serial Bus Headers

Three additional USB headers are located near the WOL header on the serverboard. JUSB2 includes USB2/3 and JUSB3 is for USB4. These are included for connection to the ports on the front of the chassis. A USB cable (not included) is needed for the connection. See the table on the right for pin definitions.

Front Panel Universal Serial Bus Pin Definitions (JUSB2/3)			
USB2		USB3	
Pin #	Definition	Pin #	Definition
1	+5V	1	+5V
2	PO-	2	PO-
3	PO+	3	PO+
4	Ground	4	Ground
5	N/A	5	N/A

## Power LED/Speaker

On the JDI header, pins 1-3 are for a power LED, pins 4-7 are for the speaker. See the table on the right for speaker pin definitions. **Note:** The speaker connector pins are for use with an external speaker. If you wish to use the onboard speaker, you should close pins 6-7 with a jumper.

Speaker Connector Pin Definitions (JD1)		
Pin #	Function	Definition
4	+	Speaker data (red wire)
5	Key	No connection
6		Key
7		Speaker data

## ATX PS/2 Keyboard and PS/2 Mouse Ports

The ATX PS/2 keyboard and the PS/2 mouse ports are located on the I/O back plane. See the table on the right for pin definitions.

PS/2 Keyboard and Mouse Port Pin Definitions (Kb, Mouse)	
Pin#	Definition
1	Data
2	NC
3	Ground
4	VCC
5	Clock
6	NC

## Overheat LED

Connect an LED to the JOH header to provide warning of a chassis overheating condition. See the table on the right for pin definitions.

Overheat LED Pin Definitions (JOH)	
Pin#	Definition
1	+5V
2	OH Active

## Wake-On-LAN

The Wake-On-LAN header is designated WOL. See the table on the right for pin definitions. You must enable the LAN Wake-Up setting in BIOS to use this feature. You must also have a LAN card with a Wake-on-LAN connector and cable.

Wake-On-LAN Pin Definitions (WOL)	
Pin#	Definition
1	+5V Standby
2	Ground
3	Wake-up

## Wake-On-Ring

The Wake-On-Ring header is designated JWOR. This function allows your computer to receive and "wake-up" by an incoming call to the modem when in suspend state. See the table on the right for pin definitions. You must have a WOR card and cable to use this feature.

Wake-On-Ring Pin Definitions (JWOR)	
Pin#	Definition
1	Ground (Black)
2	Wake-up

## SMB

The System Management Bus header (for the PCI bus) designated SMB is located near the SATA ports. Connect the appropriate cable here to utilize SMB on your system. See the table on the right for pin definitions.

SMB Header Pin Definitions (SMB)	
Pin#	Definition
1	Data
2	Ground
3	Clock
4	No Connection

## SMBUS\_PS

The SMBUS\_PS header is for I<sup>2</sup>C, which may be used to monitor the status of the power supply, fan and system temperature. See the table on the right for pin definitions.

SMB Power (I <sup>2</sup> C) Pin Definitions (SMBUS_PS)	
Pin#	Definition
1	Clock
2	Data
3	Power Fail
4	Ground
5	+3.3V

## SGPIO

The two headers labeled SGPIO1 and SGPIO2 are for SGPIO (Serial General Purpose Input/Output). SGPIO provides a bus between the SATA controller and the SATA drive backplane to provide SATA enclosure management functions. Connect the appropriate cables from the backplane to the SGPIO1 and SGPIO2 headers to utilize SATA management functions on your system.

## 5-9 Jumper Settings

### Explanation of Jumpers

To modify the operation of the serverboard, jumpers can be used to choose between optional settings. Jumpers create shorts between two pins to change the function of the connector. Pin 1 is identified with a square solder pad on the printed circuit board. See the diagram at right for an example of jumping pins 1 and 2. Refer to the serverboard layout page for jumper locations.

**Note:** On two-pin jumpers, "Closed" means the jumper is on and "Open" means the jumper is off the pins.

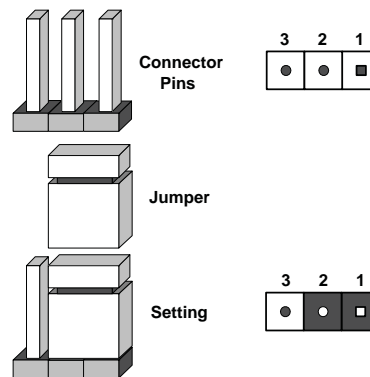

### CMOS Clear

JBT1 is used to clear CMOS and will also clear any passwords. Instead of pins, this jumper consists of contact pads to prevent accidentally clearing the contents of CMOS.

To clear CMOS,

- 1) First power down the system and unplug the power cord(s)
- 2) With the power disconnected, short the CMOS pads with a metal object such as a small screwdriver
- 3) Remove the screwdriver (or shorting device)
- 4) Reconnect the power cord(s) and power on the system.

**Note:** *Do not use the PW ON connector to clear CMOS.*

### JLAN Enable/Disable

Change the setting of jumper JPL1 and JPL2 to enable or disable the on-board LAN ports JLAN1 and JLAN2, respectively. See the table on the right for jumper settings. The default setting is enabled

JLAN Enable/Disable Jumper Settings (JPL1/JPL2)	
Jumper Setting	Definition
Pins 1-2	Enabled
Pins 2-3	Disabled

### Watch Dog Enable/Disable

JWD controls the Watch Dog function. Watch Dog is a system monitor that can reboot the system when a software application hangs. Pins 1-2 will cause WD to reset the system if an application hangs. Pins 2-3 will generate a non-maskable interrupt signal for the application that is hung up. See the table on the right for jumper settings. Watch Dog must also be enabled in BIOS.

Watch Dog Jumper Settings (JWD)	
Jumper Setting	Definition
Pins 1-2	Reset
Pins 2-3	NMI
Open	Disabled

**Note:** When enabled, the user needs to write their own application software to disable the Watch Dog Timer.

### 3rd Power Supply Fail Detect Enable/Disable

The system can notify you in the event of a power supply failure. This feature assumes that three power supply units are installed in the chassis with one acting as a backup. If you only have one or two power supply units installed, you should disable this (the default setting) with J3P to prevent false alarms. See the table on the right for jumper settings.

3rd Power Supply Fail Detect Enable/Disable Jumper Settings (J3P)	
Jumper Setting	Definition
Open	Disabled
Closed	Enabled

### Alarm Reset (JAR)

The system will notify you in the event of a power supply failure. This feature assumes that Supermicro redundant power supply units are installed in the chassis. If you only have a single power supply installed, you should not connect anything to this jumper to prevent false alarms. See the table on the right for jumper settings.

Alarm Reset Jumper Settings (JAR)	
Pin#	Definition
2	+5V
1	Ground

### VGA Enable/Disable

JPG1 allows you to enable or disable the VGA port. The default position is on pins 1 and 2 to enable VGA. See the table on the right for jumper settings.

VGA Enable/Disable Jumper Settings (JPG1)	
Jumper Setting	Definition
Pins 1-2	Enabled
Pins 2-3	Disabled

### SCSI Controller Enable/Disable (6025B-8R+ only)

Jumper JPA1 is used to enable or disable the onboard SCSI controller. The default setting is on pins 1-2 to enable SCSI. See the table on the right for jumper settings.

SCSI Enable/Disable Jumper Settings (JPA1)	
Both Jumpers	Definition
Pins 1-2	Enabled
Pins 2-3	Disabled

### SCSI Termination Enable/Disable (6025B-8R+ only)

Jumpers JPA2/JPA3 are used to enable or disable termination for the SCSI Channel A (JPA2) and Channel B (JPA3) connectors. The default setting is open to enable termination. See the table on the right for jumper settings.

SCSI Term. Enable/Disable Jumper Settings (JPA2/JPA3)	
Jumper Setting	Definition
Open	Enabled
Closed	Disabled

**Note:** In order for the SCSI drives to function properly, please do not change the default setting (enabled) set by the manufacturer.

### Compact Flash Master/Slave Select

A Compact Flash Master (Primary)/Slave (Secondary) Select jumper is located at JCF1. Close this jumper to enable the use of a compact flash card. For the compact flash card and JCF1 to work properly, you will first need to connect the compact flash card's power cable to JWF1. See the table on the right for jumper settings.

Compact Flash Card Master/Slave Select (JCF1)	
Jumper	Definition
Open	Slave (Secondary)
Closed	Master (Primary)

### SMBUS to PCI Enable/Disable

The J27 and J28 pair of jumpers allows you to connect the System Management Bus to the PCI expansion slots. The default setting is closed (on) for both jumpers to enable the connection. Both connectors must be set the same (J27 is for data and J28 is for the clock). See the table on right for jumper settings.

SMBUS to PCI Enable/Disable (J27/J28)	
Jumper Setting	Definition
Closed	Enabled
Open	Disabled

## 5-10 Onboard Indicators

### JLAN1/JLAN2 LEDs

Each Ethernet port has two LEDs. The yellow (right) LED indicates activity while the left LED may be green, amber or off to indicate the speed of the connection. See the table on the right for the functions associated with the left (connection speed) LED.

JLAN Left LED (Connection Speed Indicator)	
LED Color	Definition
Off	10 MHz
Green	100 MHz
Amber	1 GHz

### SCSI Activity LED Indicators

There are two SCSI Activity LED indicators on the X7DB8+. DA1 indicates the activity status of SCSI Channel A and DA2 indicates the activity status of SCSI Channel B.

### Onboard Power LED

LE1 is a power LED located beside JP1. When this LED is lit, the system is on. Be sure to turn off the system and unplug the power cord before removing or installing components.

## 5-11 Parallel Port, Floppy and Hard Drive Connections

Note the following when connecting the floppy and hard disk drive cables:

- The floppy disk drive cable has seven twisted wires.
- A red mark on a wire typically designates the location of pin 1.
- A single floppy disk drive ribbon cable has 34 wires and two connectors to provide for two floppy disk drives. The connector with twisted wires always connects to drive A, and the connector that does not have twisted wires always connects to drive B.

### Parallel Port Connector

See the table below for pin definitions of the parallel (printer) port.

Parallel (Printer) Port Connector Pin Definitions			
Pin#	Definition	Pin #	Definition
1	Strobe-	2	Auto Feed-
3	Data Bit 0	4	Error-
5	Data Bit 1	6	Init-
7	Data Bit 2	8	SLCT IN-
9	Data Bit 3	10	GND
11	Data Bit 4	12	GND
13	Data Bit 5	14	GND
15	Data Bit 6	16	GND
17	Data Bit 7	18	GND
19	ACK	20	GND
21	BUSY	22	Write Data
23	PE	24	Write Gate
25	SLCT	26	NC

## Floppy Connector

The floppy connector is located near the IDE connectors. See the table below for pin definitions.

Floppy Drive Connector Pin Definitions (Floppy)			
Pin#	Definition	Pin #	Definition
1	Ground	2	FDHDIN
3	Ground	4	Reserved
5	Key	6	FDEDIN
7	Ground	8	Index
9	Ground	10	Motor Enable
11	Ground	12	Drive Select B
13	Ground	14	Drive Select B
15	Ground	16	Motor Enable
17	Ground	18	DIR
19	Ground	20	STEP
21	Ground	22	Write Data
23	Ground	24	Write Gate
25	Ground	26	Track 00
27	Ground	28	Write Protect
29	Ground	30	Read Data
31	Ground	32	Side 1 Select
33	Ground	34	Diskette

## SATA Ports

There are no jumpers to configure the onboard SATA connectors. See the table on the right for pin definitions.

SATA Connector Pin Definitions (SATA0 - SATA5)	
Pin #	Definition
1	Ground
2	TXP
3	TXN
4	Ground
5	RXN
6	RXP
7	Ground

## IDE Connectors

There are two IDE connectors: IDE#1 (blue) and IDE#2 (white). IDE#1 is designated as the primary IDE drive. IDE#2 is designated as the secondary IDE drive and is reserved for Compact Flash card use only. See the table below for pin definitions.

**Note:** IDE#2 is reserved for Compact Flash card use only. Do not use it for other devices. If IDE#2 is populated with a Compact Flash card, IDE#1 will only support one device. For the Compact Flash card to work properly, you will first need to connect a power cable to JWF1.

IDE Drive Connectors Pin Definitions (IDE#1)			
Pin#	Definition	Pin #	Definition
1	Reset IDE	2	Ground
3	Host Data 7	4	Host Data 8
5	Host Data 6	6	Host Data 9
7	Host Data 5	8	Host Data 10
9	Host Data 4	10	Host Data 11
11	Host Data 3	12	Host Data 12
13	Host Data 2	14	Host Data 13
15	Host Data 1	16	Host Data 14
17	Host Data 0	18	Host Data 15
19	Ground	20	Key
21	DRQ3	22	Ground
23	I/O Write	24	Ground
25	I/O Read	26	Ground
27	IOCHRDY	28	BALE
29	DACK3	30	Ground
31	IRQ14	32	IOCS16
33	Addr1	34	Ground
35	Addr0	36	Addr2
37	Chip Select 0	38	Chip Select 1
39	Activity	40	Ground

## Ultra320 SCSI Connectors (6025B-8R+ only)

There are two SCSI connectors on the serverboard. SCSI Channel A is located at JA1 and SCSI Channel B is located at JA2. Refer to the table at right for the pin definitions.

Ultra320 SCSI Drive Connector Pin Definitions (JA1/JA2)			
Pin#	Definition	Pin #	Definition
1	+DB (12)	35	-DB (12)
2	+DB (13)	36	-DB (13)
3	+DB (14)	37	-DB (14)
4	+DB (15)	38	-DB (15)
5	+DB (P1)	39	-DB (P1)
6	+DB (0)	40	-DB (0)
7	+DB (1)	41	-DB (1)
8	+DB (2)	42	-DB (2)
9	+DB (3)	43	-DB (3)
10	+DB (4)	44	-DB (4)
11	+DB (5)	45	-DB (5)
12	+DB (6)	46	-DB (6)
13	+DB (7)	47	-DB (7)
14	+DB (P)	48	-DB (P)
15	Ground	49	Ground
16	DIFFSENS	50	Ground
17	TERMPWR	51	TERMPWR
18	TERMPWR	52	TERMPWR
19	Reserved	53	Reserved
20	Ground	54	Ground
21	+ATN	55	-ATN
22	Ground	56	Ground
23	+BSY	57	-BSY
24	+ACK	58	-ACK
25	+RST	59	-RST
26	+MSG	60	-MSG
27	+SEL	61	-SEL
28	+C/D	62	-C/D
29	+REQ	63	-REQ
30	+I/O	64	-I/O
31	+DB (8)	65	-DB (8)
32	+DB (9)	66	-DB (9)
33	+DB (10)	67	-DB (10)
34	+DB (11)	68	-DB (11)

## Chapter 6

### Advanced Chassis Setup

This chapter covers the steps required to install components and perform maintenance on the SC825TQ-R700LP/SC825S2-R700LP chassis. For component installation, follow the steps in the order given to eliminate the most common problems encountered. If some steps are unnecessary, skip ahead to the step that follows.

#### Tools Required

The only tool you will need to install components and perform maintenance is a Philips screwdriver.

#### 6-1 Static-Sensitive Devices

Electrostatic discharge (ESD) can damage electronic components. To prevent damage to any printed circuit boards (PCBs), it is important to handle them very carefully. The following measures are generally sufficient to protect your equipment from ESD damage.

##### Precautions

- Use a grounded wrist strap designed to prevent static discharge.
- Touch a grounded metal object before removing any board from its antistatic bag.
- Handle a board by its edges only; do not touch its components, peripheral chips, memory modules or gold contacts.
- When handling chips or modules, avoid touching their pins.
- Put the motherboard, add-on cards and peripherals back into their antistatic bags when not in use.
- For grounding purposes, make sure your computer chassis provides excellent conductivity between the power supply, the case, the mounting fasteners and the serverboard.

##### Unpacking

The serverboard is shipped in antistatic packaging to avoid static damage. When unpacking the board, make sure the person handling it is static protected.

---

Figure 6-1. Front and Rear Chassis Views

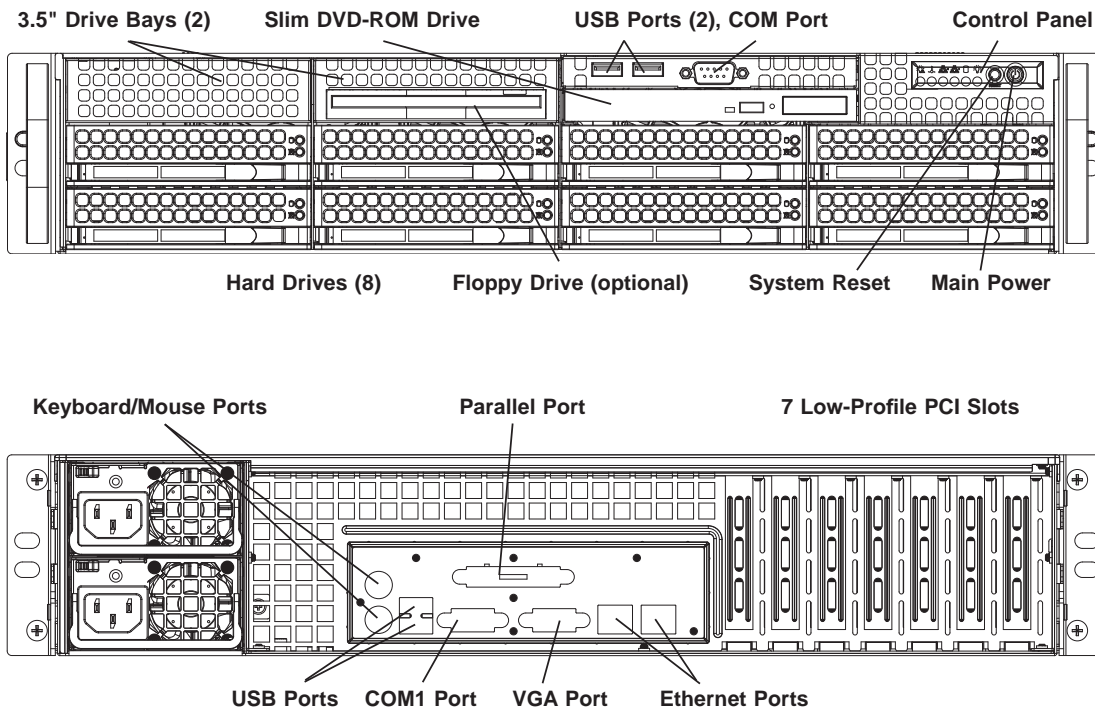

## 6-2 Control Panel

The control panel (located on the front of the chassis) must be connected to the JF1 connector on the serverboard to provide you with system status indications. A ribbon cable has bundled these wires together to simplify the connection. Connect the cable from JF1 on the serverboard to JP4 on the Control Panel PCB (printed circuit board). Make sure the red wire plugs into pin 1 on both JF1 and JP4. Pull all excess cabling out of the airflow path. The LEDs inform you of system status. See Chapter 3 for details on the LEDs and the control panel buttons. Details on JF1 can be found in Chapter 5.

## 6-3 System Fans

Three 8-cm hot-swap fans provide the cooling for the SuperServer 6025B-TR+/6025B-8R+. It is very important that the chassis top cover is properly installed and making a good seal in order for the cooling air to circulate properly through the chassis and cool the components. See Figure 6-2.

### System Fan Failure

Fan speed is controlled by system temperature via a BIOS setting. If a fan fails, the remaining fans will ramp up to full speed and the overheat/fan fail LED on the control panel will turn on. Replace any failed fan at your earliest convenience with the same type and model (the system can continue to run with a failed fan). Remove the top chassis cover while the system is still running to determine which of the fans has failed.

### Replacing System Fans

#### 1. Removing a fan

Remove the chassis cover. Press the tabs on the sides of the fan to unlock and remove the fan and its housing. The fan's power connections will automatically detach. System power does not need to be shut down since the fans are hot-pluggable.

#### 2. Installing a new fan

Replace the failed fan with an identical 8-cm, 12 volt fan (available from Supermicro, p/n FAN-0070). Position the new fan into the space vacated by the failed fan previously removed. A "click" can be heard when the fan is fully installed in place and the power connections are made. If the system power is on, the hot-plug feature will cause the fan to start immediately upon being connected to its header on the serverboard.

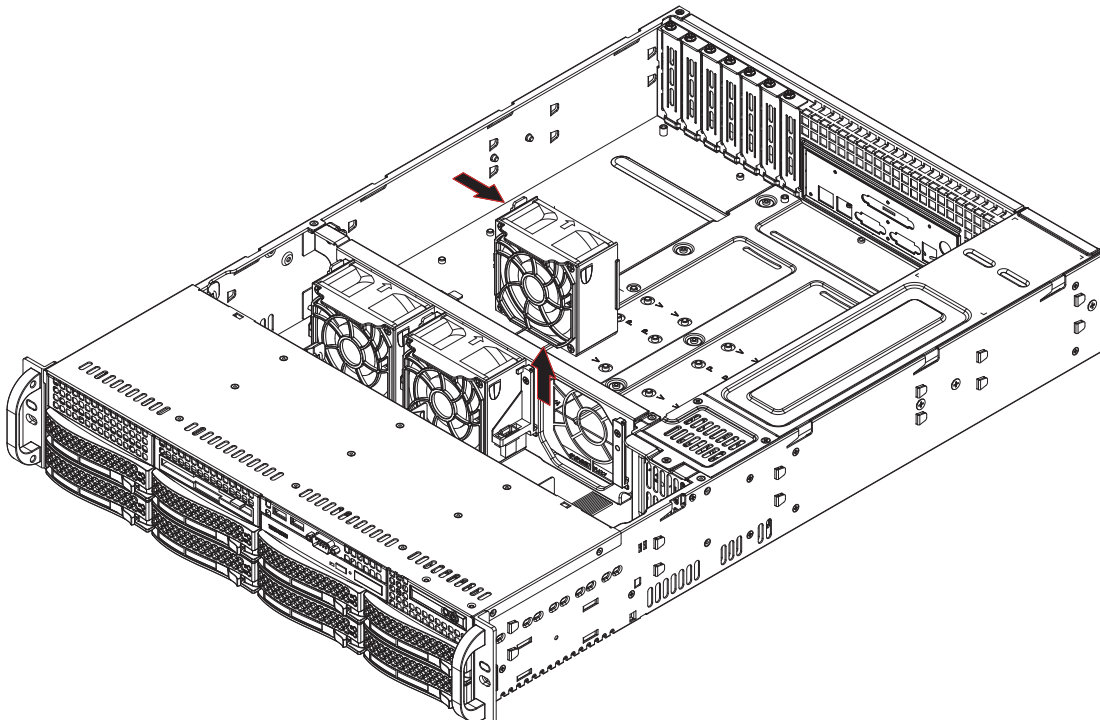
**Figure 6-2. Removing System Cooling Fans**

## 6-4 Drive Bay Installation/Removal

### Accessing the Drive Bays

SATA/SCSI Drives: You do not need to access the inside of the chassis or remove power to replace or swap SATA/SCSI drives. Proceed to the next step for instructions. **Note:** You must use standard 1" high, SATA/SCSI drives in the SuperServer 6025B-TR+/6025B-8R+.

DVD-ROM/Floppy Disk Drive: For installing/removing the DVD-ROM or floppy disk drive, you will need to gain access to the inside of the server by removing the top cover of the chassis. Proceed to the "DVD-ROM and Floppy Drive Installation" section later in this chapter for instructions.

5.25" Drive Bay: For installing/removing a component in the 5.25" drive bay, proceed to the "5.25" Drive Bay Installation" section later in this chapter for instructions.

## SATA/SCSI Drive Installation

### 1. Mounting a SATA/SCSI drive in a drive carrier

The SATA/SCSI drives are mounted in drive carriers to simplify their installation and removal from the chassis. These carriers also help promote proper airflow for the drives. For this reason, even empty carriers without SATA/SCSI drives installed must remain in the chassis. To add a new SATA/SCSI drive, install a drive into the carrier with the printed circuit board side facing down so that the mounting holes align with those in the carrier. Secure the drive to the carrier with four screws, as shown in Figure 6-3.

Figure 6-3. Mounting a SATA/SCSI Drive in a Carrier

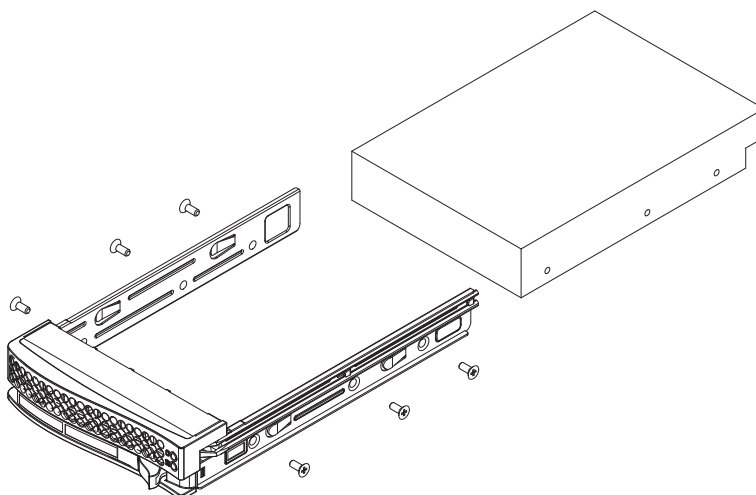

Use caution when working around the SATA/SCSI backplane. Do not touch the backplane with any metal objects and make sure no ribbon cables touch the backplane or obstruct the holes, which aid in proper airflow.



**Important:** Regardless of how many SATA/SCSI hard drives are installed, all drive carriers must remain in the drive bays to maintain proper airflow.

## 2. Installing/removing hot-swap SATA/SCSI drives

The SATA/SCSI drive carriers are all easily accessible at the front of the chassis. These hard drives are hot-pluggable, meaning they can be removed and installed without powering down the system. To remove a carrier, push the release button located beside the drive LEDs. Then swing the colored handle fully out and use it to pull the unit straight out (see Figure 6-4).

**Note:** Your operating system must have RAID support to enable the hot-plug capability of the SATA/SCSI drives.

Figure 6-4. Removing a Serial ATA Drive Carrier

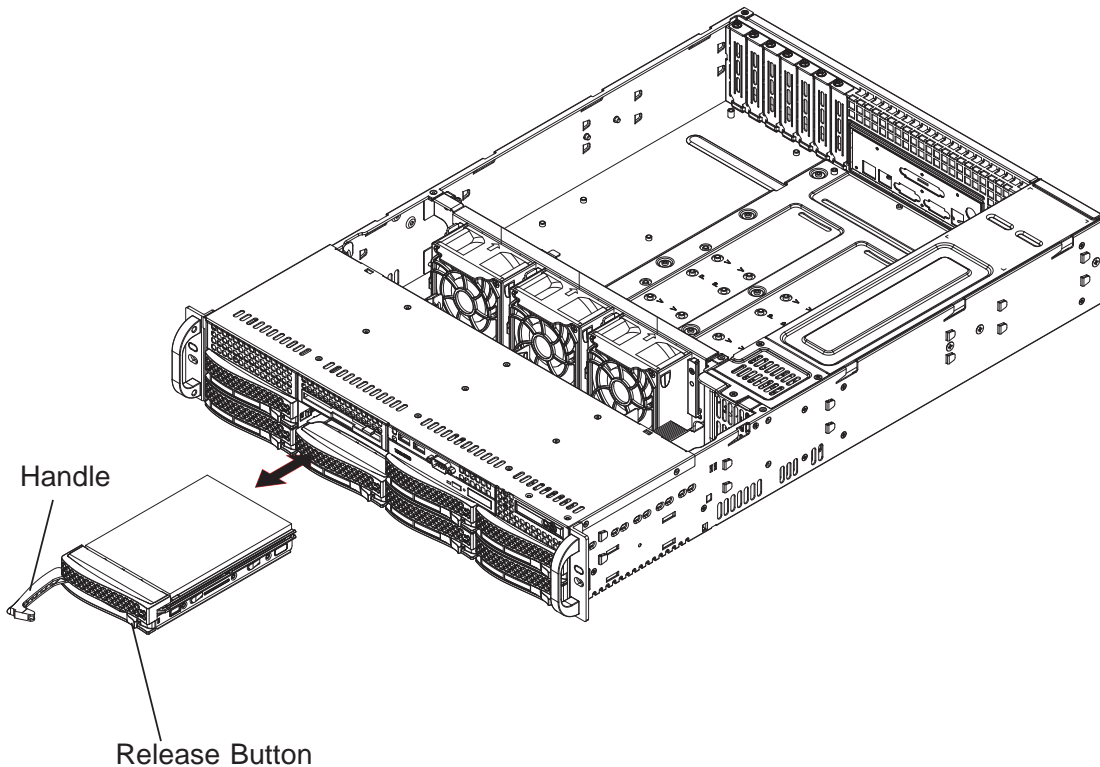

**Important:** All of the SATA/SCSI drive carriers must remain in the drive bays to maintain proper cooling airflow.

## Hard Drive Backplane

The SATA/SCSI drives plug into a backplane that provides power, drive ID and bus termination. A RAID controller can be used with the backplane to provide data security. The operating system you use must have RAID support to enable the hot-swap capability of the Serial ATA drives. The backplane is already preconfigured, so there are no jumpers or switches present on it.

## DVD-ROM and Floppy Drive Installation

The top cover of the chassis must be opened to gain full access to the DVD-ROM and floppy drive bays. The 6025B-TR+/6025B-8R+ accommodates only slim type DVD-ROM drives. Side mounting brackets are typically needed to mount a slim DVD-ROM drive in the 6025B-TR+/6025B-8R+ server.

First, release the retention screws that secure the server unit to the rack. Grasp the two handles on either side and pull the unit straight out until it locks (you will hear a "click"). Next, depress the two buttons on the top of the chassis to release the top cover and at the same time, push the cover away from you until it stops. You can then lift the top cover from the chassis to gain full access to the inside of the server. You must power down the system before installing or removing floppy or IDE components.

Drives mount on rails and should "click" into place to be correctly and fully installed in their bays.

- The floppy disk drive cable has seven twisted wires.
- A color mark on a cable typically designates the location of pin 1.
- A single floppy disk drive ribbon cable has 34 wires and two connectors to provide for two floppy disk drives. The connector with twisted wires always connects to drive A, and the connector that does not have twisted wires always connects to drive B.

## 6-5 Power Supply

The SuperServer 6025B-TR+/6025B-8R+ has a 700 watt redundant power supply consisting of two power modules. Each power supply module has an auto-switching capability, which enables it to automatically sense and operate at a 100V - 240V input voltage.

### Power Supply Failure

If either of the two power supply modules fail, the other module will take the full load and allow the system to continue operation without interruption. The PWR Fail LED will illuminate and remain on until the failed unit has been replaced. Replacement units can be ordered directly from Supermicro (see contact information in the Preface). The power supply units have a hot-swap capability, meaning you can replace the failed unit without powering down the system.

### Removing/Replacing the Power Supply

You do not need to shut down the system to replace a power supply unit. The backup power supply module will keep the system up and running while you replace the failed hot-swap unit. Replace with the same model (see part number in the Appendix), which can be ordered directly from Supermicro.

#### 1. Removing the power supply

First unplug the power cord from the failed power supply module. Then depress the locking tab on the power supply module and use the handle to pull it straight out with the rounded handle.

#### 2. Installing a new power supply

Replace the failed hot-swap unit with another identical power supply unit. Simply push the new power supply unit into the power bay until you hear a click. Secure the locking tab on the unit and finish by plugging the AC power cord back into the unit.

# Chapter 7

## BIOS

### 7-1 Introduction

This chapter describes the Phoenix BIOS™ Setup utility for the X7DBE+/X8DB8+. The Phoenix ROM BIOS is stored in a flash chip and can be easily upgraded using a floppy disk-based program.

**Note:** Due to periodic changes to the BIOS, some settings may have been added or deleted and might not yet be recorded in this manual. Please refer to the Manual Download area of the Supermicro web site <<http://www.supermicro.com>> for any changes to the BIOS that may not be reflected in this manual.

#### System BIOS

The BIOS is the Basic Input Output System used in all IBM® PC, XT™, AT®, and PS/2® compatible computers. The Phoenix BIOS flash chip stores the system parameters, types of disk drives, video displays, etc. in the CMOS. The CMOS memory requires very little electrical power. When the computer is turned off, a backup battery provides power to the BIOS flash chip, enabling it to retain system parameters. Each time the computer is powered on the computer is configured with the values stored in the BIOS ROM by the system BIOS, which gains control at boot up.

#### How To Change the Configuration Data

The CMOS information that determines the system parameters may be changed by entering the BIOS Setup utility. This Setup utility can be accessed by pressing the <Delete> key at the appropriate time during system boot. (See below.)

#### Starting the Setup Utility

Normally, the only visible POST (Power On Self Test) routine is the memory test. As the memory is being tested, press the <Delete> key to enter the main menu of the BIOS Setup utility. From the main menu, you can access the other setup screens, such as the Security and Power menus. Beginning with Section 7-3, detailed descriptions are given for each parameter setting in the Setup utility.

**Warning!** To prevent possible boot failure, do not shut down or reset the system while updating the BIOS.

## 7-2 Running Setup

*Default settings are in bold text unless otherwise noted.*

The BIOS setup options described in this section are selected by choosing the appropriate text from the main BIOS Setup screen. All displayed text is described in this section, although the screen display is often all you need to understand how to set the options (see next page).

When you first power on the computer, the Phoenix BIOS™ is immediately activated.

While the BIOS is in control, the Setup program can be activated in one of two ways:

1. By pressing <Delete> immediately after turning the system on, or
2. When the message shown below appears briefly at the bottom of the screen during the POST (Power On Self-Test), press the <Delete> key to activate the main Setup menu:

**Press the <Delete> key to enter Setup**

## 7-3 Main BIOS Setup

All main Setup options are described in this section. The main BIOS Setup screen is displayed below.

Use the Up/Down arrow keys to move among the different settings in each menu. Use the Left/Right arrow keys to change the options for each setting.

Press the <Esc> key to exit the CMOS Setup Menu. The next section describes in detail how to navigate through the menus.

Items that use submenus are indicated with the ► icon. With the item highlighted, press the <Enter> key to access the submenu.

## Main BIOS Setup Menu

PhoenixBIOS Setup - Copyright 1985-2004 Phoenix Technologies Ltd.				
Main	Advanced	Security	Boot	Exit
System Time:	[17:08:53]	Item Specific Help  <Tab>, <Shift-Tab>, or <Enter> selects field.		
System Date:	[12-01-2005]			
Legacy Diskette A:	[1.44/1.25 MB 3½"]			
▶ IDE Channel 0 Master	[CD-ROM]			
▶ IDE Channel 0 Slave	[None]			
▶ SATA Port 0	[None]			
▶ SATA Port 1	[None]			
▶ SATA Port 2	[None]			
▶ SATA Port 3	[None]			
Parallel ATA:	[Enabled]			
Serial ATA:	[Enabled]			
Native Mode Operation:	[Auto]			
SATA Controller Mode Option:	[Compatible]			
System Memory:	[XXXX KB]			
Extended Memory:	[XXXX KB]			
F1 Help   ↑↓ Select Item   -/+ Change Values   F9 Setup Defaults Esc Exit   ←→ Select Menu   Enter Select ▶ Sub-Menu   F10 Previous Values				

### Main Setup Features

#### System Time

To set the system date and time, key in the correct information in the appropriate fields. Then press the <Enter> key to save the data.

#### System Date

Using the arrow keys, highlight the month, day and year fields, and enter the correct data. Press the <Enter> key to save the data.

#### BIOS Date

This field displays the date when this version of BIOS was built.

#### Legacy Diskette A

This setting allows the user to set the type of floppy disk drive installed as diskette A. The options are Disabled, 360Kb 5.25 in, 1.2MB 5.25 in, 720Kb 3.5 in, **1.44/1.25MB**, 3.5 in and 2.88MB 3.5 in.

## ► IDE Channel 0 Master/Slave, SATA Port0, SATA Port1, SATA Port2 and SATA Port3

These settings allow the user to set the parameters of IDE Channel 0 Master/Slave, IDE Channel 1 Master/Slave, IDE Channel 2 Master, IDE Channel 3 Master slots. Hit <Enter> to activate the following sub-menu screen for detailed options of these items. Set the correct configurations accordingly. The items included in the sub-menu are:

PhoenixBIOS Setup - Copyright 1985-2004 Phoenix Technologies Ltd.	
Main	
Type: CHS Format Cylinders: Cylinders: Heads: [ 1 ] Heads: Sectors: Sectors: Maximum Capacity: Maximum Capacity: LBA Format Total Sectors: Maximum Capacity:  Multi-Sector Transfers: [Disabled] LBA Mode Control: [Disabled] 32 Bit I/O: [Disabled] Transfer Mode: [Standard] Ultra DMA Mode: [Disabled]	Item Specific Help  User = you enter parameters of hard-disk drive installed at this connection. Auto = autotypes hard-disk drive installed here. CD-ROM = a CD-ROM drive is installed here. ATAPI Removable = removable disk drive installed here.
F1 Help    ↑↓ Select Item    -/+ Change Values    F9 Setup Defaults Esc Exit    ↔ Select Menu    Enter Select ► Sub-Menu    F10 Previous Values	

### Type

Selects the type of IDE hard drive. The options are **Auto**, (which allows the BIOS to automatically determine the hard drive's capacity, number of heads, etc.), a number from 1-39 to select a predetermined type of hard drive, CDROM and ATAPI Removable. The option "User" will allow the user to enter the parameters of the HDD installed at this connection. The option "Auto" will allow the BIOS to automatically configure the parameters of the HDD installed at the connection. Choose the option 1-39 to select a predetermined HDD type. Select CDROM if a CDROM drive is installed. Select ATAPI if a removable disk drive is installed.

### CHS Format

The following items will be displayed by the BIOS:

**Type:** This item displays the type of CPU.

**Cylinders:** This item indicates the status of cylinders.

**Headers:** This item indicates the number of headers.

**Sectors:** This item displays the number of sectors.

**Maximum Capacity:** This item displays the maximum storage capacity of the system.

### LBA Format

The following items will be displayed by the BIOS:

**Total Sectors:** This item displays the number of total sectors available in the LBA Format.

**Maximum Capacity:** This item displays the maximum capacity in the LBA Format.

### Multi-Sector Transfer

This item allows the user to specify the number of sectors per block to be used in multi-sector transfer. The options are Disabled, 4 Sectors, 8 Sectors, and **16 Sectors**.

### LBA Mode Control

This item determines whether the Phoenix BIOS will access the IDE Channel 0 Master Device via the LBA mode. The options are **Enabled** and Disabled.

### 32 Bit I/O

This option allows the user to enable or disable the function of 32-bit data transfer. The options are Enabled and **Disabled**.

### Transfer Mode

This option allows the user to set the transfer mode. The options are Standard, Fast PIO1, Fast PIO2, Fast PIO3, Fast PIO4, FPIO3/DMA1 and FPIO4/DMA2.

### Ultra DMA Mode

This option allows the user to select Ultra DMA Mode. The options are **Disabled**, Mode 0, Mode 1, Mode 2, Mode 3, Mode 4, and Mode 5.

### **Parallel ATA**

This setting allows the user to enable or disable the function of Parallel ATA. The options are Disabled, Channel 0, Channel 1, and **Both**.

### **Serial ATA**

This setting allows the user to enable or disable the function of Serial ATA. The options are Disabled and **Enabled**.

### **Native Mode Operation**

Select the native mode for ATA. The options are: Parallel ATA, Serial ATA, Both, and **Auto**.

### **SATA Controller Mode**

Select **Compatible** to allow the SATA and PATA drives to be automatically-detected and be placed in the Legacy Mode by the BIOS. Select Enhanced to allow the SATA and PATA drives to be to be automatically-detected and be placed in the Native IDE Mode.

**Note:** The Enhanced mode is supported by the Windows 2000 OS or a later version.

When the SATA Controller Mode is set to "Enhanced", the following items will display:

#### **Serial ATA (SATA) RAID Enable**

Select Enable to enable Serial ATA RAID Functions. (\*For the Windows OS environment, use the RAID driver if this feature is set to Enabled. When this item is set to Enabled, the item: "ICH RAID Code Base" will be available for you to select Intel or Adaptec Host RAID Controller. If this item is set to **Disabled**, the item: SATA AHCI Enable will be available. ) The options are Enabled and **Disabled**.

#### **SATA AHCI**

Select Enable to enable the function of Serial ATA Advanced Host Interface. (Exercise caution when using this function. This feature is for advanced programmers only.) The options are Enabled and **Disabled**.

#### **ICH RAID Code Base**

Select Intel to enable Intel's ICH HostRAID Controller. Select Adaptec to use Adaptec's HostRAID Driver. The options are **Intel** and Adaptec.

## System Memory

This display informs you how much system memory is recognized as being present in the system.

## Extended Memory

This display informs you how much extended memory is recognized as being present in the system.

## 7-4 Advanced Setup

Choose Advanced from the Phoenix BIOS Setup Utility main menu with the arrow keys. You should see the following display. The items with a triangle beside them have sub menus that can be accessed by highlighting the item and pressing <Enter>. Options for PIR settings are displayed by highlighting the setting option using the arrow keys and pressing <Enter>. All Advanced BIOS Setup options are described in this section.

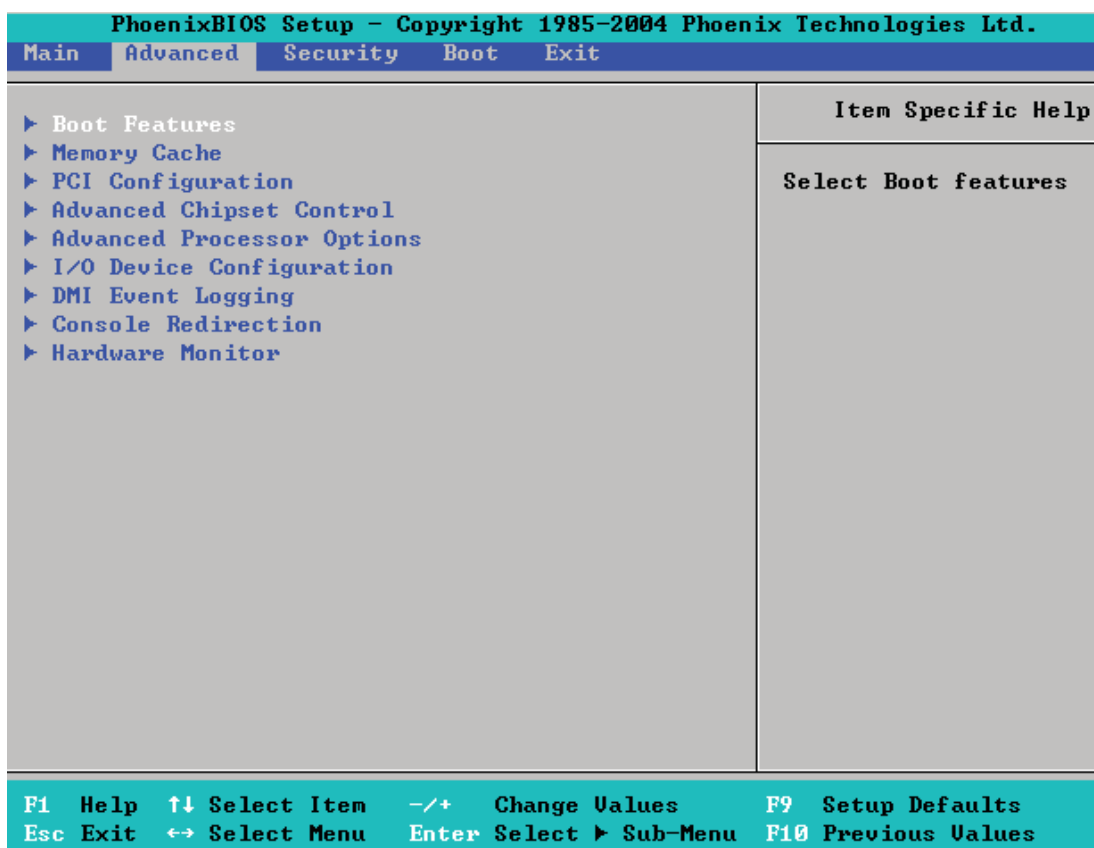

## ► **Boot Features**

Access the submenu to make changes to the following settings.

### **Quick Boot Mode**

If enabled, this feature will speed up the POST (Power On Self Test) routine by skipping certain tests after the computer is turned on. The settings are **Enabled** and **Disabled**. If **Disabled**, the POST routine will run at normal speed.

### **Quiet Boot**

This setting allows you to **Enable** or **Disable** the diagnostic screen during boot-up.

### **ACPI Mode**

Use the setting to determine if you want to employ ACPI (Advanced Configuration and Power Interface) power management on your system. The options are **Yes** and **No**.

### **Power Button Behavior**

If set to **Instant-Off**, the system will power off immediately as soon as the user hits the power button. If set to **4-sec.**, the system will power off when the user presses the power button for 4 seconds or longer. The options are **instant-off** and **4-sec override**.

### **Resume On Modem Ring**

Select **On** to “wake your system up” when an incoming call is received by your modem. The options are **On** and **Off**.

### **Power Loss Control**

This setting allows you to choose how the system will react when power returns after an unexpected loss of power. The options are **Stay Off**, **Power On**, and **Last State**.

### **Watch Dog**

If enabled, this option will automatically reset the system if the system is not active for more than 5 minutes. The options are **Enabled** and **Disabled**.

### **Summary Screen**

This setting allows you to **Enable** or **Disable** the summary screen which displays the system configuration during bootup.

## ► Memory Cache

### Cache System BIOS Area

This setting allows you to designate a reserve area in the system memory to be used as a System BIOS buffer to allow the BIOS write (cache) its data into this reserved memory area. Select "**Write Protect**" to enable this function, and this area will be reserved for BIOS ROM access only. Select "Uncached" to disable this function and make this area available for other devices.

### Cache Video BIOS Area

This setting allows you to designate a reserve area in the system memory to be used as a Video BIOS buffer to allow the BIOS write (cache) its data into this reserved memory area. Select "**Write Protect**" to enable the function and this area will be reserved for Video BIOS ROM access only. Select "Uncached" to disable this function and make this area available for other devices.

### Cache Base 0-512K

If enabled, this feature will allow the data stored in the base memory area: block 0-512K to be cached (written) into a buffer, a storage area in the Static DROM (SDROM) or to be written into the CPU's L1 and L2 cache to speed up CPU operations. Select "Uncached" to disable this function. Select "Write Through" to allow data to be cached into the buffer and written into system memory at the same time. Select "Write Protect" to prevent data from being written into Block 0-512K. Select "Write Back" to allow CPU to write data back directly from the buffer without writing data to the System Memory for fast CPU data processing and operation. The options are Uncached, Write Through, Write Protect, and **Write Back**.

### Cache Base 512K-640K

If enabled, this feature will allow the data stored in the memory area: 512K-640K to be cached (written) into a buffer, a storage area in the Static DROM (SDROM) or written into the CPU's L1, L2, and L3 cache to speed up CPU operations. Select "Uncached" to disable this function. Select "Write Through" to allow data to be cached into the buffer and written into the system memory at the same time. Select "Write Protect" to prevent data from being written into the base memory area of Block 0-512K. Select "Write Back" to allow CPU to write data back directly from the buffer without writing data to the System Memory for fast CPU data processing and operation. The options are Uncached, Write Through, Write Protect, and **Write Back**.

### Cache Extended Memory

If enabled, this feature will allow the data stored in the extended memory area to be cached (written) into a buffer, a storage area in the Static DROM (SDROM) or written into L1, L2, L3 cache inside the CPU to speed up CPU operations.

Select "Uncached" to disable this function. Select "Write Through" to allow data to be cached into the buffer and written into the system memory at the same time. Select "Write Protect" to prevent data from being written into the base memory area of Block 0-512K. Select "Write Back" to allow CPU to write data back directly from the buffer without writing data to the System Memory for fast CPU data processing and operation. The options are Uncached, Write Through, Write Protect, and **Write Back**.

### **Discrete MTRR Allocation**

If enabled, MTRRs (-Memory Type Range Registers) are configured as distinct, separate units and cannot be overlapped. If enabled, the user can achieve better graphic effects when using a Linux graphic driver that requires the write-combining configuration with 4GB or more memory. The options are Enabled and **Disabled**.

### **►PCI Configuration**

Access the submenu to make changes to the following settings for PCI devices.

#### **Onboard GLAN1/Onboard GLAN2 (Gigabit- LAN) OPROM Configure**

Enabling this option provides the capability to boot from GLAN. The options are Disabled and **Enabled**.

#### **Onboard SCSI OPROM Configure**

Enabling this option provides the capability to boot from SCSI HDD. The options are Disabled and **Enabled**.

#### **Reset Configuration Data**

If set to Yes, this setting clears the Extended System Configuration Data- (ESCD) area. The options are Yes and **No**.

#### **Frequency for PCI-X#1, PCI-X#2, PCI-X#3**

This option allows the user to change the bus frequency for the devices installed in the slot indicated. The options are **Auto**, PCI 33 MHz, PCI 66 MHz, PCI-X 66 MHz, PCI-X 100 MHz, and PCI-X 133 MHz.

#### **Frequency for PCI-X#1 On Riser, Frequency for PCI-X#2-#3 On Riser** (Available when an Active Riser Card is present.)

This option allows the user to change the bus frequency of the devices installed in the slot indicated. The options are **Auto**, PCI 33 MHz, PCI 66 MHz, PCI-X 66 MHz, PCI-X 100 MHz, and PCI-X 133 MHz.

► **Slot#1 PCI 100 MHz ZCR, Slot#2 PCI-X 133MHz, Slot#3 PCI-X 133MHz, Slot#4 PCI-Exp x8, Slot#5 PCI-Exp x8, and Slot#6 PCI-Exp x4**

Access the submenu for each of the settings above to make changes to the following:

### **Option ROM Scan**

When enabled, this setting will initialize the device expansion ROM. The options are **Enabled** and Disabled.

### **Enable Master**

This setting allows you to enable the selected device as the PCI bus master. The options are Enabled and **Disabled**.

### **Latency Timer**

This setting allows you to set the clock rate for Bus Master. A high-priority, high-throughput device may benefit from a greater clock rate. The options are **Default**, 0020h, 0040h, 0060h, 0080h, 00A0h, 00C0h, and 00E0h. For Unix, Novell and other Operating Systems, please select the option: other. If a drive fails after the installation of a new software, you might want to change this setting and try again. A different OS requires a different Bus Master clock rate.

### **Large Disk Access Mode**

This setting determines how large hard drives are to be accessed. The options are **DOS** or Other (for Unix, Novelle NetWare and other operating systems).

### ► **Advanced Chipset Control**

Access the submenu to make changes to the following settings.

**Warning!** Exercise caution when changing the Advanced settings. Incorrect values entered may cause system malfunction. Also, a very high DRAM frequency or incorrect DRAM timing may cause system instability. When this occurs, revert to the default settings.

### **SERR Signal Condition**

This setting specifies the ECC Error conditions that an SERR# is to be asserted. The options are None, **Single Bit**, Multiple Bit, and Both.

### **4GB PCI Hole Granularity**

This feature allows you to select the granularity of PCI hole for PCI slots. If MTRRs are not enough, this option may be used to reduce MTRR occupation. The options are: **256 MB**, 512 MB, 1GB and 2GB.

### **Memory Branch Mode**

This option allows the BIOS to enumerate Host Mode for Device 16, Function 1, Reg. 40h bit 16 and Reg. 58h [14]. The options are **Interleave**, Sequential, Mirroring, and **Single Channel 0**.

### **Branch 0 Rank Sparing**

Select **enable** to enable the sparing feature for Branch 0 Rank. The options are Enabled and **Disabled**.

### **Branch 1 Rank Sparing**

Select **enable** to enable the sparing feature for Branch 0 Rank. The options are Enabled and **Disabled**.

### **Enhanced x8 Detection**

Select **Enabled** to enable Enhanced x8 DRAM UC Error Detection . The options are Disabled and **Enabled**.

### **Route Port 80h Cycles to**

This feature allows the user to decide which bus to send debug information to. The options are Disabled, PCI and **LPC**.

### **Clock Spectrum Feature**

If Enabled, the BIOS will monitor the level of Electromagnetic Interference caused by the components and will attempt to decrease the interference whenever needed. The options are Enabled and **Disabled**.

### **Enabling Multi-Media Timer**

Select Yes to activate a set of timers that are alternative to the traditional 8254 timers for the OS use. The options are Yes and **No**.

### **USB Function**

Select Enabled to enable the function of USB devices specified. The settings are **Enabled** and Disabled.

### **USB Device 29 F3 Only**

Select Enabled to enable the function of USB device as specified. The settings are **Enabled** and Disabled.

### **Legacy USB Support**

This setting allows you to enable support for Legacy USB devices. The settings are **Enabled** and Disabled.

## ► Advanced Processor Options

Access the submenu to make changes to the following settings.

### CPU Speed

This is a display that indicates the speed of the installed processor.

### Hyper-threading (Available when supported by the CPU.)

Set to Enabled to use the Hyper-Threading Technology, which will result in increased CPU performance. The options are Disabled and **Enabled**.

### Machine Checking (Available when supported by the CPU.)

Set to Enabled to activate the function of Machine Checking and allow the CPU to detect and report hardware (machine) errors via a set of model-specific registers (MSRs). The options are Disabled and **Enabled**.

### Thermal Management 2 (Available when supported by the CPU.)

Set to Enabled to use Thermal Management 2 (TM2) which will lower CPU voltage and frequency when the CPU temperature reaches a predefined overheat threshold. Set to **Disabled** to use Thermal Manager 1 (TM1), allowing CPU clocking to be regulated via CPU Internal Clock modulation when the CPU temperature reaches the overheat threshold.

### C1 Enhanced Mode (Available when supported by the CPU.)

Set to Enabled to enable Enhanced Halt State to lower CPU voltage/frequency to prevent overheat. The options are Enabled and **Disabled**. (Please refer to Intel's web site for detailed information.)

### No Execute Mode Memory Protection (Available when supported by the CPU and the OS.)

Set to Enabled to enable Execute Disable Bit and allow the processor to classify areas in memory where an application code can execute and where it cannot, and thus preventing a worm or a virus from inserting and creating a flood of codes to overwhelm the processor or damage the system during an attack.

**Note:** this feature is available when your OS and your CPU support the function of Execute Disable Bit.) The options are **Disabled** and Enabled. (Note: For more information regarding hardware/software support for this function, please refer to Intel's and Microsoft's web sites.)

### Adjacent Cache Line Prefetch (Available when supported by the CPU.)

The CPU fetches the cache line for 64 bytes if this option is set to Disabled. The CPU fetches both cache lines for 128 bytes as comprised if Enabled. The options are Disabled and **Enabled**.

### Set Maximum Extended CPUID=3

Select Enabled to set the Maximum Extended CPUID value to 3. The options are Enabled and **Disabled**.

### Intel <R> Virtualization Technology

Select Enabled to use the feature of Virtualization Technology. The options are Enabled and **Disabled**.

### ► I/O Device Configuration

Access the submenu to make changes to the following settings.

#### KBC Clock Input

This setting allows you to select clock frequency for KBC. The options are 6MHz, 8MHz, **12MHz**, and 16MHz.

#### Serial Port A

This setting allows you to assign control of serial port A. The options are **Enabled** (user defined), Disabled, and Auto (BIOS- or OS- controlled).

##### Base I/O Address

This setting allows you to select the base I/O address for serial port A. The options are **3F8**, 2F8, 3E8, and 2E8.

##### Interrupt

This setting allows you to select the IRQ (interrupt request) for serial port A. The options are IRQ3 and **IRQ4**.

#### Serial Port B

This setting allows you to assign control of serial port B. The options are **Enabled** (user defined), Disabled, Auto (BIOS controlled) and OS Controlled.

##### Mode

This setting allows you to set the type of device that will be connected to serial port B. The options are **Normal** and IR (for an infrared device).

##### Base I/O Address

This setting allows you to select the base I/O address for serial port B. The options are 3F8, **2F8**, 3E8 and 2E8.

##### Interrupt

This setting allows you to select the IRQ (interrupt request) for serial port B. The options are **IRQ3** and IRQ4.

### **Parallel Port**

This setting allows you to assign control of the parallel port. The options are **Enabled** (user defined), Disabled and Auto (BIOS-or OS- controlled).

#### **Base I/O Address**

Select the base I/O address for the parallel port. The options are **378**, 278 and 3BC.

#### **Interrupt**

This setting allows you to select the IRQ (interrupt request) for the parallel port. The options are IRQ5 and **IRQ7**.

#### **Mode**

This feature allows you to specify the parallel port mode. The options are Output only, Bi-Directional, EPP and **ECP**.

#### **DMA Channel**

This item allows you to specify the DMA channel for the parallel port. The options are DMA1 and **DMA3**.

### **Floppy Disk Controller**

This setting allows you to assign control of the floppy disk controller. The options are **Enabled** (user defined), Disabled, and Auto (BIOS and OS controlled).

#### **Base I/O Address**

This setting allows you to select the base I/O address for the Floppy port. The options are **Primary** and Secondary.

## ► DMI Event Logging

Access the submenu to make changes to the following settings.

### **Event Log Validity**

This is a display to inform you of the event log validity. It is not a setting.

### **Event Log Capacity**

This is a display to inform you of the event log capacity. It is not a setting.

### **View DMI Event Log**

Highlight this item and press <Enter> to view the contents of the event log.

### **Event Logging**

This setting allows you to **Enable** or Disable event logging.

### **ECC Event Logging**

This setting allows you to **Enable** or Disable ECC event logging.

### **Mark DMI Events as Read**

Highlight this item and press <Enter> to mark the DMI events as read.

### **Clear All DMI Event Logs**

Select Yes and press <Enter> to clear all DMI event logs. The options are Yes and **No**.

## ► Console Redirection

Access the submenu to make changes to the following settings.

### COM Port Address

This item allows you to specify to redirect the console to Onboard COM A or Onboard COM B. This setting can also be **Disabled**.

### BAUD Rate

This item allows you to select the BAUD rate for console redirection. The options are 300, 1200, 2400, 9600, **19.2K**, 38.4K, 57.6K, and 115.2K.

### Console Type

This item allows you to choose from the available options to select the console type for console redirection. The options are VT100, VT100,8bit, PC-ANSI, 7bit, **PC ANSI**, VT100+, and VT-UTF8.

### Flow Control

This item allows you to choose from the available options to select the flow control for console redirection. The options are: None, XON/XOFF, and **CTS/RTS**.

### Console Connection

This item allows you to choose select the console connection: either **Direct** or Via Modem.

### Continue CR after POST

Choose whether to continue with console redirection after the POST routine. The options are On and **Off**.

## ► Hardware Monitor Logic

### CPU Temperature Threshold

This option allows the user to set a CPU temperature threshold that will activate the alarm system when the CPU temperature reaches this pre-set temperature threshold. The options are 70°C, 75°C, **80°C** and 85°C.

Highlight this and hit <Enter> to see monitor data for the following items:

**CPU1 Temperature:** This item displays CPU1 Temperature.

**CPU2 Temperature:** This item displays CPU2 Temperature.

**LM93 Temperature:** This item displays LM93 Temperature.

**Fan 1-FAN8:** If the feature of Auto Fan Control is enabled, the BIOS will automatically display the status of the fans indicated in this item.

### Fan Speed Control Modes

This feature allows the user to decide how the system controls the speeds of the onboard fans. The CPU temperature and the fan speed are correlative. When the CPU on-die temperature increases, the fan speed will also increase, and vice versa. If the option is set to “3-pin fan”, the fan speed is controlled by voltage. If the option is set to “4-pin”, the fan speed will be controlled by Pulse Width Modulation (PWM). Select “3-pin” if your chassis came with 3-pin fan headers. Select “4-pin” if your chassis came with 4-pin fan headers. Select “Workstation” if your system is used as a Workstation. Select “Server” if your system is used as a Server. Select “Disable” to disable the fan speed control function to allow the onboard fans to run at the full speed (12V) at all the time. The Options are: **1. Disable**, 2. 3-pin (Server), 3. 3-pin (Workstation), 4. 4-pin (Server) and 5. 4-pin (Workstation).

### Voltage Monitoring

The following items will be monitored and displayed:

**P12V\_VR0**

**P12V\_VR1**

**FSB VTT**

**PXH Vcore**

**ES2B Vcore**

**CPU1Vcore**

**CPU2Vcore**

**P3V3**

## 7-5 Security

Choose Security from the Phoenix BIOS Setup Utility main menu with the arrow keys. You should see the following display. Security setting options are displayed by highlighting the setting using the arrow keys and pressing <Enter>. All Security BIOS settings are described in this section.

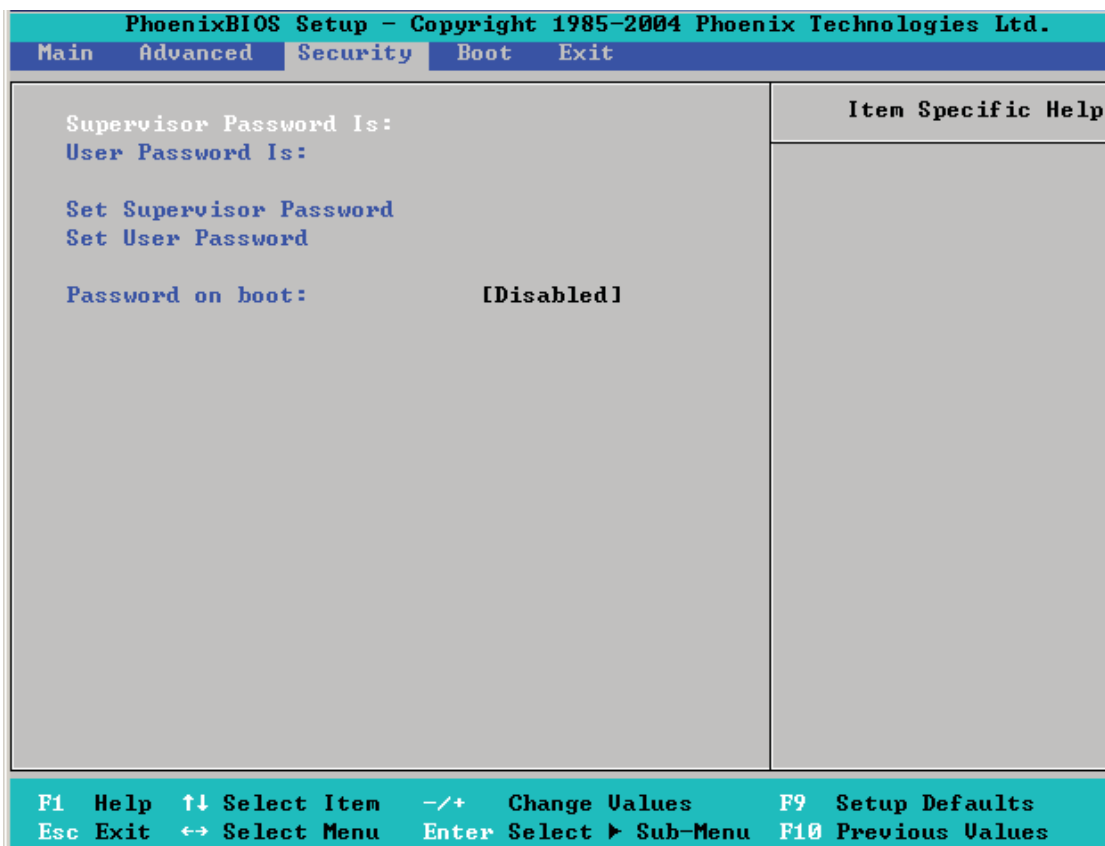

### Supervisor Password Is:

This displays whether a supervisor password has been entered for the system. Clear means such a password has not been used and Set means a supervisor password has been entered for the system.

### User Password Is:

This displays whether a user password has been entered for the system. Clear means such a password has not been used and Set means a user password has been entered for the system.

### Set Supervisor Password

When the item "Set Supervisor Password" is highlighted, hit the <Enter> key. When prompted, type the Supervisor's password in the dialogue box to set or to change supervisor's password, which allows access to the BIOS.

## Set User Password

When the item "Set User Password" is highlighted, hit the <Enter> key. When prompted, type the user's password in the dialogue box to set or to change the user's password, which allows access to the system at boot-up.

## Password on Boot

This setting allows you to require a password to be entered when the system boots up. The options are Enabled (password required) and Disabled (password

## 7-6 Boot

Choose Boot from the Phoenix BIOS Setup Utility main menu with the arrow keys. You should see the following display. Highlighting a setting with a + or - will expand or collapse that entry. See details on how to change the order and specs of boot devices in the Item Specific Help window. All Boot BIOS settings are described in this section.

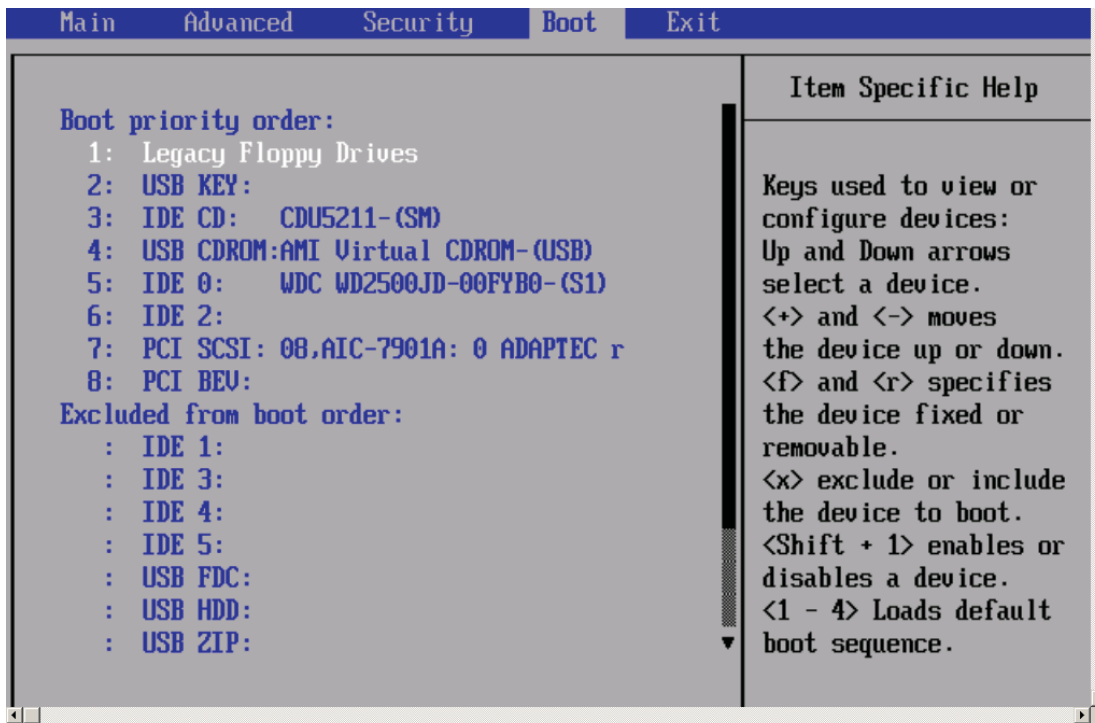

## Boot Priority Order/Excluded from Boot Order.

Use the Up and Down Arrow Keys to select a device. Use a <+> key or a <-> key to move the device up or down. Use the <f> key or the <r> key to specify the devices. You can also use the keys indicated above to specify the priority of boot order of a device or to move items from the category of "Excluded from Boot Order" to the category of "Boot Priority Order" and vice versa. See details on how to change the priority of boot order of devices in the "Item Specific Help" window.

## 7-7 Exit

Choose Exit from the Phoenix BIOS Setup Utility main menu with the arrow keys. You should see the following display. All Exit BIOS settings are described in this section.

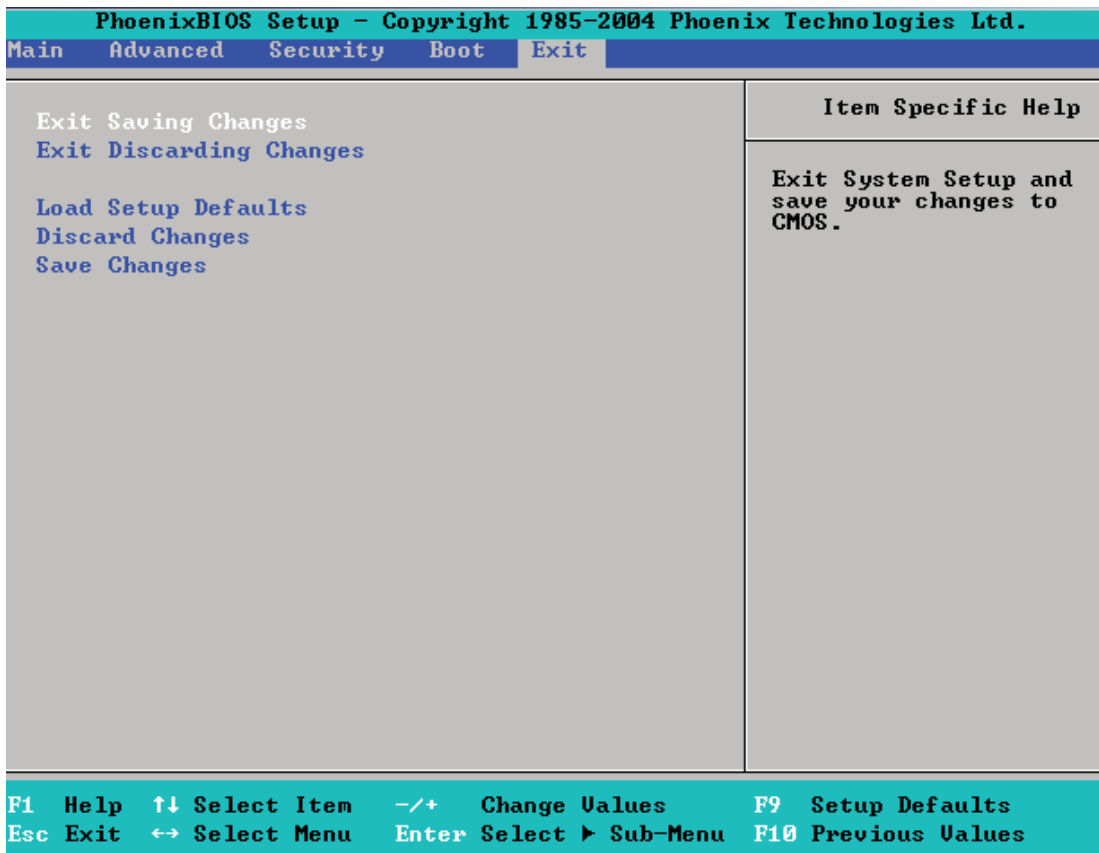

### **Exit Saving Changes**

Highlight this item and hit <Enter> to save any changes you made and to exit the BIOS Setup utility.

### **Exit Discarding Changes**

Highlight this item and hit <Enter> to exit the BIOS Setup utility without saving any changes you may have made.

### **Load Setup Defaults**

Highlight this item and hit <Enter> to load the default settings for all items in the BIOS Setup. These are the safest settings to use.

### **Discard Changes**

Highlight this item and hit <Enter> to discard (cancel) any changes you made. You will remain in the Setup utility.

### **Save Changes**

Highlight this item and hit <Enter> to save any changes you made. You will remain in the Setup utility.

## Appendix A

### BIOS POST Messages

During the Power-On Self-Test (POST), the BIOS will check for problems. If a problem is found, the BIOS will activate an alarm or display a message. The following is a list of such BIOS messages.

**Failure Fixed Disk**

Fixed disk is not working or not configured properly. Check to see if fixed disk is attached properly. Run Setup. Find out if the fixed-disk type is correctly identified.

**Stuck key**

Stuck key on keyboard.

**Keyboard error**

Keyboard not working.

**Keyboard Controller Failed**

Keyboard controller failed test. May require replacing keyboard controller.

**Keyboard locked - Unlock key switch**

Unlock the system to proceed.

**Monitor type does not match CMOS - Run SETUP**

Monitor type not correctly identified in Setup

**Shadow Ram Failed at offset: nnnn**

Shadow RAM failed at offset **nnnn** of the 64k block at which the error was detected.

**System RAM Failed at offset: nnnn**

System RAM failed at offset **nnnn** of in the 64k block at which the error was detected.

**Extended RAM Failed at offset: nnnn** Extended memory not working or not configured properly at offset **nnnn**.

**System battery is dead - Replace and run SETUP**

The CMOS clock battery indicator shows the battery is dead. Replace the battery and run Setup to reconfigure the system.

**System CMOS checksum bad - Default configuration used**

System CMOS has been corrupted or modified incorrectly, perhaps by an application program that changes data stored in CMOS. The BIOS installed Default Setup Values. If you do not want these values, enter Setup and enter your own values. If the error persists, check the system battery or contact your dealer.

**System timer error**

The timer test failed. Requires repair of system board.

**Real time clock error**

Real-Time Clock fails BIOS hardware test. May require board repair.

**Check date and time settings**

BIOS found date or time out of range and reset the Real-Time Clock. May require setting legal date (1991-2099).

**Previous boot incomplete - Default configuration used**

Previous POST did not complete successfully. POST loads default values and offers to run Setup. If the failure was caused by incorrect values and they are not corrected, the next boot will likely fail. On systems with control of **wait states**, improper Setup settings can also terminate POST and cause this error on the next boot. Run Setup and verify that the waitstate configuration is correct. This error is cleared the next time the system is booted.

**Memory Size found by POST differed from CMOS**

Memory size found by POST differed from CMOS.

**Diskette drive A error**

**Diskette drive B error**

Drive A: or B: is present but fails the BIOS POST diskette tests. Check to see that the drive is defined with the proper diskette type in Setup and that the diskette drive is attached correctly.

**Incorrect Drive A type - run SETUP**

Type of floppy drive A: not correctly identified in Setup.

**Incorrect Drive B type - run SETUP**

Type of floppy drive B: not correctly identified in Setup.

**System cache error - Cache disabled**

RAM cache failed and BIOS disabled the cache. On older boards, check the cache jumpers. You may have to replace the cache. See your dealer. A disabled cache slows system performance considerably.

**CPU ID:**

CPU socket number for Multi-Processor error.

**EISA CMOS not writeable**

ServerBIOS2 test error: Cannot write to EISA CMOS.

**DMA Test Failed**

ServerBIOS2 test error: Cannot write to extended **DMA** (Direct Memory Access) registers.

**Software NMI Failed**

ServerBIOS2 test error: Cannot generate software NMI (Non-Maskable Interrupt).

**Fail-Safe Timer NMI Failed**

ServerBIOS2 test error: Fail-Safe Timer takes too long.

**device Address Conflict**

Address conflict for specified **device**.

**Allocation Error for: device**

Run ISA or EISA Configuration Utility to resolve resource conflict for the specified **device**.

**CD ROM Drive**

CD ROM Drive identified.

**Entering SETUP ...**

Starting Setup program

**Failing Bits: nnnn**

The hex number **nnnn** is a map of the bits at the RAM address which failed the memory test. Each 1 (one) in the map indicates a failed bit. See errors 230, 231, or 232 above for offset address of the failure in System, Extended, or Shadow memory.

**Fixed Disk n**

Fixed disk n (0-3) identified.

**Invalid System Configuration Data**

Problem with NVRAM (CMOS) data.

**I/O device IRQ conflict**

I/O device IRQ conflict error.

**PS/2 Mouse Boot Summary Screen:**

PS/2 Mouse installed.

**nnnn kB Extended RAM Passed**

Where nnnn is the amount of RAM in kilobytes successfully tested.

**nnnn Cache SRAM Passed**

Where nnnn is the amount of system cache in kilobytes successfully tested.

**nnnn kB Shadow RAM Passed**

Where nnnn is the amount of shadow RAM in kilobytes successfully tested.

**nnnn kB System RAM Passed**

Where nnnn is the amount of system RAM in kilobytes successfully tested.

**One or more I2O Block Storage Devices were excluded from the Setup Boot Menu**

There was not enough room in the IPL table to display all installed I2O block-storage devices.

**Operating system not found**

Operating system cannot be located on either drive A: or drive C:. Enter Setup and see if fixed disk and drive A: are properly identified.

**Parity Check 1 nnnn**

Parity error found in the system bus. BIOS attempts to locate the address and display it on the screen. If it cannot locate the address, it displays ?????. Parity is a method for checking errors in binary data. A parity error indicates that some data has been corrupted.

**Parity Check 2 nnnn**

Parity error found in the I/O bus. BIOS attempts to locate the address and display it on the screen. If it cannot locate the address, it displays **????**.

**Press <F1> to resume, <F2> to Setup, <F3> for previous**

Displayed after any recoverable error message. Press <F1> to start the boot process or <F2> to enter Setup and change the settings. Press <F3> to display the previous screen (usually an initialization error of an **Option ROM**, i.e., an add-on card). Write down and follow the information shown on the screen.

**Press <F2> to enter Setup**

Optional message displayed during POST. Can be turned off in Setup.

**PS/2 Mouse:**

PS/2 mouse identified.

**Run the I2O Configuration Utility**

One or more unclaimed block storage devices have the Configuration Request bit set in the LCT. Run an I2O Configuration Utility (e.g. the SAC utility).

**System BIOS shadowed**

System BIOS copied to shadow RAM.

**UMB upper limit segment address: nnnn**

Displays the address **nnnn** of the upper limit of **Upper Memory Blocks**, indicating released segments of the BIOS which can be reclaimed by a virtual memory manager.

**Video BIOS shadowed**

Video BIOS successfully copied to shadow RAM.

**Notes**

## Appendix B

### BIOS POST Codes

This section lists the POST (Power On Self Test) codes for the PhoenixBIOS. POST codes are divided into two categories: recoverable and terminal.

#### Recoverable POST Errors

When a recoverable type of error occurs during POST, the BIOS will display an POST code that describes the problem. BIOS may also issue one of the following beep codes:

1 long and two short beeps - video configuration error

1 repetitive long beep - no memory detected

#### Terminal POST Errors

If a terminal type of error occurs, BIOS will shut down the system. Before doing so, BIOS will write the error to port 80h, attempt to initialize video and write the error in the top left corner of the screen.

The following is a list of codes that may be written to port 80h.

POST Code	Description
02h	Verify Real Mode
03h	Disable Non-Maskable Interrupt (NMI)
04h	Get CPU type
06h	Initialize system hardware
07h	Disable shadow and execute code from the ROM.
08h	Initialize chipset with initial POST values
09h	Set IN POST flag
0Ah	Initialize CPU registers
0Bh	Enable CPU cache
0Ch	Initialize caches to initial POST values
0Eh	Initialize I/O component
0Fh	Initialize the local bus IDE
10h	Initialize Power Management
11h	Load alternate registers with initial POST values
12h	Restore CPU control word during warm boot
13h	Initialize PCI Bus Mastering devices
14h	Initialize keyboard controller

<b>POST Code</b>	<b>Description</b>
16h	1-2-2-3 BIOS ROM checksum
17h	Initialize cache before memory Auto size
18h	8254 timer initialization
1Ah	8237 DMA controller initialization
1Ch	Reset Programmable Interrupt Controller
20h	1-3-1-1 Test DRAM refresh
22h	1-3-1-3 Test 8742 Keyboard Controller
24h	Set ES segment register to 4 GB
28h	Auto size DRAM
29h	Initialize POST Memory Manager
2Ah	Clear 512 kB base RAM
2Ch	1-3-4-1 RAM failure on address line <b>xxxx*</b>
2Eh	1-3-4-3 RAM failure on data bits <b>xxxx*</b> of low byte of memory bus
2Fh	Enable cache before system BIOS shadow
32h	Test CPU bus-clock frequency
33h	Initialize Phoenix Dispatch Manager
36h	Warm start shut down
38h	Shadow system BIOS ROM
3Ah	Auto size cache
3Ch	Advanced configuration of chipset registers
3Dh	Load alternate registers with CMOS values
41h	Initialize extended memory for RomPilot
42h	Initialize interrupt vectors
45h	POST device initialization
46h	2-1-2-3 Check ROM copyright notice
47h	Initialize I20 support
48h	Check video configuration against CMOS
49h	Initialize PCI bus and devices
4Ah	Initialize all video adapters in system
4Bh	QuietBoot start (optional)
4Ch	Shadow video BIOS ROM
4Eh	Display BIOS copyright notice
4Fh	Initialize MultiBoot
50h	Display CPU type and speed
51h	Initialize EISA board
52h	Test keyboard
54h	Set key click if enabled
55h	Enable USB devices
58h	2-2-3-1 Test for unexpected interrupts
59h	Initialize POST display service
5Ah	Display prompt "Press F2 to enter SETUP"

---

---

<b>POST Code</b>	<b>Description</b>
5Bh	Disable CPU cache
5Ch	Test RAM between 512 and 640 kB
60h	Test extended memory
62h	Test extended memory address lines
64h	Jump to UserPatch1
66h	Configure advanced cache registers
67h	Initialize Multi Processor APIC
68h	Enable external and CPU caches
69h	Setup System Management Mode (SMM) area
6Ah	Display external L2 cache size
6Bh	Load custom defaults (optional)
6Ch	Display shadow-area message
6Eh	Display possible high address for UMB recovery
70h	Display error messages
72h	Check for configuration errors
76h	Check for keyboard errors
7Ch	Set up hardware interrupt vectors
7Dh	Initialize Intelligent System Monitoring
7Eh	Initialize coprocessor if present
80h	Disable onboard Super I/O ports and IRQs
81h	Late POST device initialization
82h	Detect and install external RS232 ports
83h	Configure non-MCD IDE controllers
84h	Detect and install external parallel ports
85h	Initialize PC-compatible PnP ISA devices
86h	Re-initialize onboard I/O ports.
87h	Configure Motherboard Configurable Devices (optional)
88h	Initialize BIOS Data Area
89h	Enable Non-Maskable Interrupts (NMIs)
8Ah	Initialize Extended BIOS Data Area
8Bh	Test and initialize PS/2 mouse
8Ch	Initialize floppy controller
8Fh	Determine number of ATA drives (optional)
90h	Initialize hard-disk controllers
91h	Initialize local-bus hard-disk controllers
92h	Jump to UserPatch2
93h	Build MPTABLE for multi-processor boards
95h	Install CD ROM for boot
96h	Clear huge ES segment register
97h	Fix up Multi Processor table
98h	1-2 Search for option ROMs. One long, two short beeps on checksum failure

---

<b>POST Code</b>	<b>Description</b>
99h	Check for SMART Drive (optional)
9Ah	Shadow option ROMs
9Ch	Set up Power Management
9Dh	Initialize security engine (optional)
9Eh	Enable hardware interrupts
9Fh	Determine number of ATA and SCSI drives
A0h	Set time of day
A2h	Check key lock
A4h	Initialize typematic rate
A8h	Erase F2 prompt
AAh	Scan for F2 key stroke
ACh	Enter SETUP
AEh	Clear Boot flag
B0h	Check for errors
B1h	Inform RomPilot about the end of POST.
B2h	POST done - prepare to boot operating system
B4h	1 One short beep before boot
B5h	Terminate QuietBoot (optional)
B6h	Check password (optional)
B7h	Initialize ACPI BIOS
B9h	Prepare Boot
BAh	Initialize SMBIOS
BBh	Initialize PnP Option ROMs
BCh	Clear parity checkers
BDh	Display MultiBoot menu
BEh	Clear screen (optional)
BFh	Check virus and backup reminders
C0h	Try to boot with INT 19
C1h	Initialize POST Error Manager (PEM)
C2h	Initialize error logging
C3h	Initialize error display function
C4h	Initialize system error handler
C5h	PnPnd dual CMOS (optional)
C6h	Initialize note dock (optional)
C7h	Initialize note dock late
C8h	Force check (optional)
C9h	Extended checksum (optional)
CAh	Redirect Int 15h to enable remote keyboard
CBh	Redirect Int 13h to Memory Technologies Devices such as ROM, RAM, PCMCIA, and serial disk
CCh	Redirect Int 10h to enable remote serial video

<b>POST Code</b>	<b>Description</b>
CDh	Re-map I/O and memory for PCMCIA
CEh	Initialize digitizer and display message
D2h	Unknown interrupt

**The following are for boot block in Flash ROM**

<b>POST Code</b>	<b>Description</b>
E0h	Initialize the chipset
E1h	Initialize the bridge
E2h	Initialize the CPU
E3h	Initialize system timer
E4h	Initialize system I/O
E5h	Check force recovery boot
E6h	Checksum BIOS ROM
E7h	Go to BIOS
E8h	Set Huge Segment
E9h	Initialize Multi Processor
EAh	Initialize OEM special code
EBh	Initialize PIC and DMA
ECh	Initialize Memory type
EDh	Initialize Memory size
EEh	Shadow Boot Block
EFh	System memory test
F0h	Initialize interrupt vectors
F1h	Initialize Run Time Clock
F2h	Initialize video
F3h	Initialize System Management Manager
F4h	Output one beep
F5h	Clear Huge Segment
F6h	Boot to Mini DOS
F7h	Boot to Full DOS

If the BIOS detects error 2C, 2E, or 30 (base 512K RAM error), it displays an additional word-bitmap (**xxxx**) indicating the address line or bits that failed. For example, "2C 0002" means address line 1 (bit one set) has failed. "2E 1020" means data bits 12 and 5 (bits 12 and 5 set) have failed in the lower 16 bits. The BIOS also sends the bitmap to the port-80 LED display. It first displays the checkpoint code, followed by a delay, the high-order byte, another delay, and then the loworder byte of the error. It repeats this sequence continuously.

## Notes

# Appendix C

## Software Installation

After all the hardware has been installed, you must first configure Intel's ESB2 SATA RAID\* before you install the Windows Operating System and other software drivers.

### **Important Notes:**

If you do not wish to configure onboard SATA RAID functions, please go directly to Section C-3.

This chapter describes RAID Configuration Instructions for the Intel ESB2 RAID Controller designed for Windows OS.

### **C-1 Introduction**

To configure the SATA RAID functions, you must first use the Intel ESB2 SATA RAID Utility program to configure the RAID Level that you desire before installing the Windows XP/2000/2003 operating system and other software drivers. (The necessary drivers are all included on the Supermicro CD that came packaged with your serverboard.) Note that the current version of the ESB2 SATA RAID Utility can only support Windows XP/2000/2003 Operating Systems.

#### **Serial ATA (SATA)**

Serial ATA (SATA) is a physical storage interface that uses a single cable with a minimum of four wires to create a point-to-point connection between devices. It is a serial link, which supports transfer rates up to 3Gbps. Because the serial cables used in SATA are thinner than the traditional cables used in Parallel ATA (PATA), SATA systems have better airflow and can be installed in smaller chassis than Parallel ATA. In addition, the cables used in PATA are limited to a length of 40cm, while Serial ATA cables can be up to one meter in length. Overall, SATA provides better functionality than PATA.

#### **Introduction to Intel ESB2 Serial RAID**

Located in the South Bridge of the Blackford Mukilteo chipset, the I/O Controller Hub (ESB2) provides the I/O subsystem with access to the rest of the system. It supports a single-channel UltraATA/100 Bus Master IDE controller (PATA) and six Serial ATA (SATA) ports. The ESB2 supports the following PATA and SATA device configurations: Legacy mode and Native mode.

## RAID Configurations

The following types of RAID configurations are supported:

RAID 0 (Data Striping): this writes data in parallel, interleaved ("striped") sections of two hard drives. Data transfer rate is doubled over using a single disk.

RAID1 (Data Mirroring): an identical data image from one drive is copied to another drive. The second drive must be the same size or larger than the first drive.

RAID 10 (Striping & Mirroring): RAID 0 and 1 schemes are combined (without parity information) to get the benefits of both.

RAID 5: both data and parity information are striped and mirrored across three or more hard drives.

## Intel Matrix Storage

The Intel Matrix Storage, supported by the ESB2, allows the user to create RAID 0, RAID 1, RAID 10 and RAID 5 sets by using only six identical hard disk drives. The Intel Matrix Storage Technology creates two partitions on each hard disk drive and generate a virtual RAID 0, RAID 1, RAID 10 and RAID 5 sets. It also allows you the change the HDD partition size without any data.

## Configuring BIOS for SATA RAID Functions (Native Mode)

1. Press the <Del> key during system bootup to enter the BIOS Setup Utility.

**Note:** If it is the first time powering on the system, we recommend you load the Optimized Default Settings. If you have already done so, please skip to Step 3.

2. Use the arrow keys to select the "Exit" Settings. Once in the "Exit" settings, Scroll down to select "Load Optimized Default Settings" and press the <Enter> key. Select "OK" to confirm the selection. Press the <Enter> key to load the default settings for the BIOS.

3. Use the arrow keys to select the "Main" section in BIOS.

4. Scroll down to "SATA Control Mode" and press the <Enter> key to select "Enhanced"

5. Scroll down to "SATA RAID Enabled" and press <Enter>. Then, select "Enabled."

6. Scroll down to "Exit". Select "Save and Exit" from the "Exit" menu. Press the <Enter> key to save the changes and exit the BIOS.

7. Once you've exited the BIOS Utility, the system will re-boot.

8. During the system boot-up, press the <Ctrl> and <I> keys simultaneously to run the Intel RAID Configuration Utility when prompted by the following message: *Press <Ctrl> <I> for Intel RAID Configuration Utility.*

## Using the Intel ESB2 SATA RAID Utility Program

### 1. Creating, Deleting and Resetting RAID Volumes

- a. After the system exits from the BIOS Setup Utility, it will automatically reboot. The following screen appears after the Power-On Self Test.

```

RAID Volumes :
None defined.

Physical Disks :
Port Drive Model      Serial #              Size   Type/Status(Vol ID)
0   HDC WD2500SD-01K   WD-NMAL72834971      232.9GB Non-RAID Disk
1   HDC WD2500SD-01K   WD-NMAL72834599      232.9GB Non-RAID Disk
2   HDC WD2500JD-00F   WD-NMAEH1376109      232.9GB Non-RAID Disk
3   HDC WD2500JD-00F   WD-NMAEH1449527      232.9GB Non-RAID Disk

Press <CTRL-I> to enter Configuration Utility...

Adaptec SCSI BIOS v4.30.0
Copyright 2003 Adaptec, Inc. All Rights Reserved.

<<< Press <Ctrl><A> for SCSISelect(TM) Utility! >>>

Slot Ch ID LUN Vendor      Product              Size Bus Status
-----
04  A  10  0

```

- b. When you see the above screen, press the <Ctrl> and the <I> keys simultaneously to have the main menu of the SATA RAID Utility appear:

**Note:** All graphics and screen shots shown in this manual are for reference only. The screen shots shown in the manual do not imply Supernicro's endorsement or non-endorsement of any 3rd party's product. Your screens may or many not look exactly the same as the graphics shown in this manual.

## Creating a RAID 0 Volume

- a. Select "Create RAID Volume" from the main menu and press the <Enter> key. The following screen will appear:

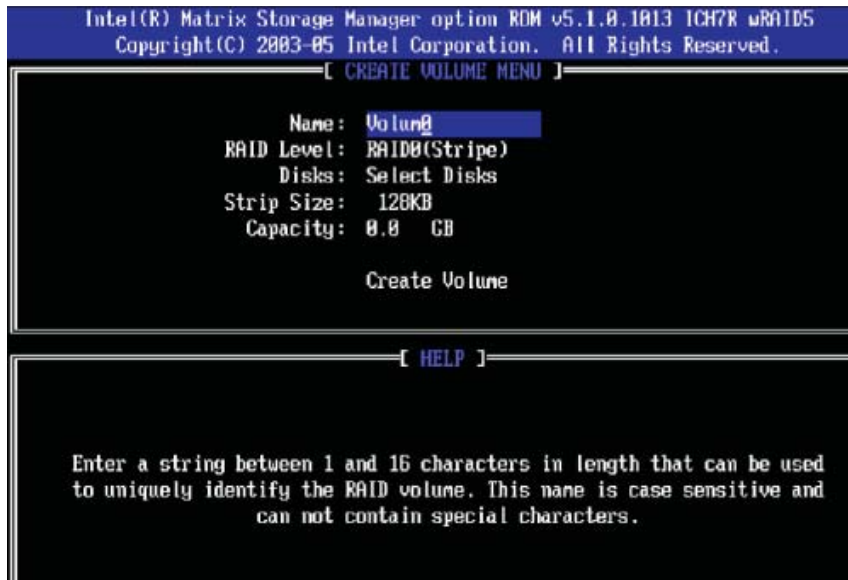

- b. Specify a name for the **RAID 0** set and press the <Tab> key or the <Enter> key to go to the next field. (You can use the <Esc> key to select the previous menu.)
- c. When RAID Level item is highlighted, press the <Up Arrow>, <Down Arrow> keys to select **RAID 0 (Stripe)** and hit <Enter>.
- d. When the Disks item is highlighted, press <Enter> to select the HDD to configure as RAID. The following pop-up screen displays:

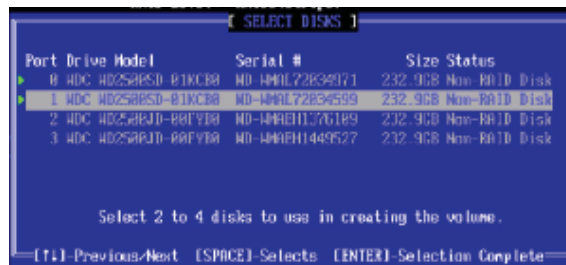

- e. Use the <Up Arrow> and <Down Arrow> keys to highlight a drive and press <Space> to select it. A triangle appears to confirm the selection of the drive.
- f. Use the <Up Arrow>, <Down Arrow> keys to select the stripe size, ranged from 4 KB to 128 KB for the RAID 0 array, and hit <Enter>. (\*Note: For a server, please use a lower stripe size, and for a multimedia system, use a higher stripe size. The default stripe size is 128 KB.)
- g. Press <Enter> when the Create Volume item is highlighted. A warning message displays.
- h. When asked "Are you sure you want to create this volume (Y/N), press "Y" to create the RAID volume, or type "N" to go back to the Create Volume menu.

## Creating a RAID 1 Volume

- a. Select "Create RAID Volume" from the main menu and press the <Enter> key. The following screen will appear:

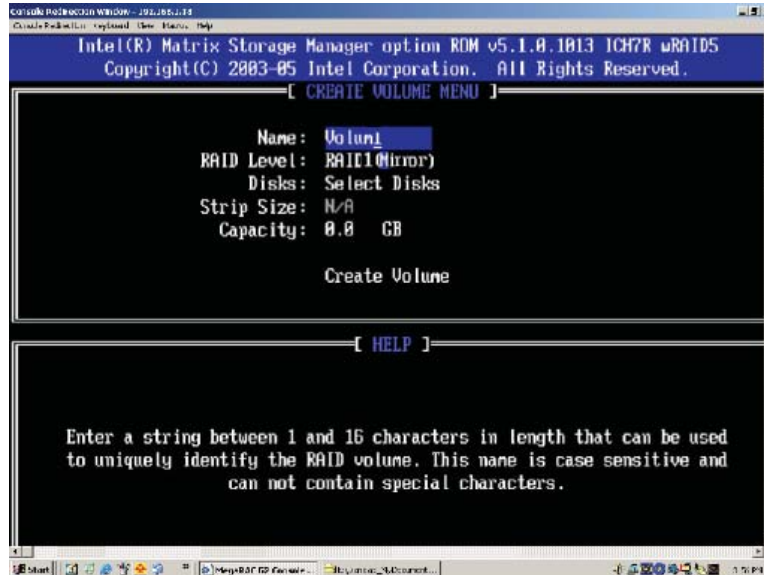

- b. Specify a name for the **RAID 1** set and press the <Tab> key or the <Enter> key to go to the next field. (You can use the <Esc> key to select the previous menu.)
- c. When RAID Level item is highlighted, press the <Up Arrow>, <Down Arrow> keys to select **RAID 1 (Mirror)** and hit <Enter>.
- d. When the Capacity item is highlighted, enter your RAID volume capacity and hit <Enter>. The default setting is the maximum capacity allowed.
- e. Press <Enter> when the Create Volume item is highlighted. A warning message displays.
- f. When asked "Are you sure you want to create this volume (Y/N), press "Y" to create the RAID volume, or type "N" to go back to the Create Volume menu.

## Creating a RAID 10 (RAID 1+ RAID 0)

- a. Select "Create RAID Volume" from the main menu and press the <Enter> key. The following screen will appear:

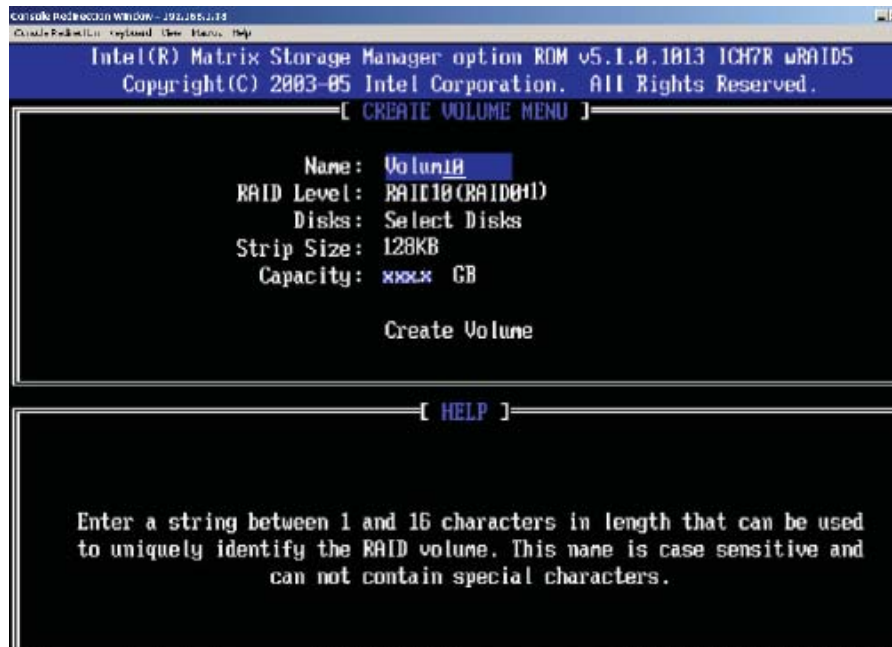

- b. Specify a name for the **RAID 10** set and press <Enter>.
- c. When RAID Level item is highlighted, use the <Up Arrow>, <Down Arrow> keys to select **RAID 10 (RAID1 + RAID0)** and hit <Enter>.
- d. When Stripe Size is highlighted, use the <Up Arrow>, <Down Arrow> keys to select the stripe size from 4 KB to 128 KB for your RAID 10 and hit <Enter>. The default setting is 6 4KB.
- Note:** For a server, please use a lower stripe size, and for a multimedia system, use a higher stripe size.
- e. When the RAID Volume Capacity item is highlighted, enter your RAID volume capacity and hit <Enter>. The default setting is the maximum capacity allowed.
- f. Press <Enter> when the Create Volume item is highlighted. A warning message displays.
- g. When asked "Are you sure you want to create this volume (Y/N)", press "Y" to create the RAID volume, or type "N" to go back to the Create Volume menu.

## Creating a RAID 5 Set (Parity)

- a. Select "Create RAID Volume" from the main menu and press the <Enter> key. The following screen will appear:



- b. Specify a name for the **RAID 5** set and press <Enter>.
- c. When the Raid Level is highlighted, use the <Up Arrow>, <Down Arrow> keys to select **RAID 5 (Parity)** and hit <Enter>.
- d. When the Disk item is highlighted, press <Enter> to select the HDD to configure as RAID.
- e. Use the <Up Arrow>, <Down Arrow> keys to highlight a drive and press <Space> to select it. A triangle appears to confirm the selection of the drive.
- f. Use the <Up Arrow>, <Down Arrow> keys to select the stripe size, ranged from 4 KB to 128 KB for the RAID 5 array, and hit <Enter>. (For a server, please use a lower stripe size, and for a multimedia system, use a higher stripe size. The default stripe size is 128 KB.)
- g. Enter your desired RAID volume capacity and press <Enter> when the capacity item is highlighted. The default setting is the maximum capacity allowed.
- h. Press Enter when the Create Volume item is highlighted. A warning message displays.
- i. When asked "Are you sure you want to create this volume (Y/N)", press "Y" to create the RAID volume, or type "N" to go back to the Create Volume menu.

## Deleting a RAID Volume



**Warning!** Be sure to back up your data before deleting a RAID set. You will lose all data on the disk drives when deleting a RAID set.

- a. From the main menu, select item2-Delete RAID Volume, and press <Enter>.
- b. Use the <Up Arrow>, <Down Arrow> keys to select the RAID set you want to delete and press <Del>. A Warning message displays.
- c. When asked "Are you sure you want to delete this volume (Y/N), press "Y" to delete the RAID volume, or type "N" to go back to the Delete Volume menu.

## Resetting to Non-RAID and Resetting a RAID HDD



**Warning!** Use cautious when resetting a RAID volume HDD to non-RAID or resetting a RAID HDD. Resetting a RAID volume HDD or resetting a RAID HDD will reformat the HDD and delete the internal RAID structure on the drive.

- a. From the main menu, select item3-Reset Disks to Non- RAID, and press <Enter>. The following screen will appear:



- b. Use the <Up Arrow>, <Down Arrow> keys to highlight the RAID set drive to reset and press <Space> to select.
- c. Press <Enter> to reset the RAID set drive. A warning message displays.
- d. Press "Y" to reset the drive or type "N" to go back to the main menu.

### Exiting the Intel Matrix Storage Manager Utility:

- a. From the main menu, select "Exit" and press <Enter>. A warning message will appear.
- b. Press "Y" to reset the drive or type "N" to go back to the main menu.

## C-2 Installing Windows XP/2000/2003 for RAID Systems

### New Operating System-Windows XP/2000/2003 Installation

- a. Insert the Microsoft Windows XP/2000/2003 Setup CD in the CD drive and the system will start booting up from CD.
- b. Press the <F6> key when the message "Press F6 if you need to install a third party SCSI or RAID driver" displays.
- c. When the Windows XP/2000/2003 setup screen appears, press "S" to specify additional device(s).
- d. Insert the driver diskette-"Intel AA RAID XP/2000/2003 Driver for ESB2 into Drive A: and press the <Enter> key.
- e. Choose Intel(R) ESB2 *SATA RAID Controller* from the list indicated in the XP/2000/2003 setup screen and press the <Enter> key.
- f. Press the <Enter> key to continue the installation process. (If you need to specify any additional devices to be installed, do it at this time.) Once all devices are specified, press the <Enter> key to continue with the installation.
- g. From the Windows XP/2000/2003 setup screen, press the <Enter> key. The XP/2000/2003 setup will automatically load all device files and then continue with the Windows XP/2000/2003 installation.
- h. After the Windows XP/2000/2003 installation is completed, the system will automatically reboot.
- i. Insert the Supermicro CD that came with the package into the CD drive during system reboot, and the screen shown in Figure C-1 will appear.

Note: the current version of the ESB2 SATA RAID Utility can only support Windows XP/2000/2003 Operating System.

## C-3 Installing the Operating System and other Software Programs

After all the hardware has been installed, you must first install the operating system, and then, other software drivers. The necessary drivers are all included on the Supermicro CDs that came packaged with your motherboard.

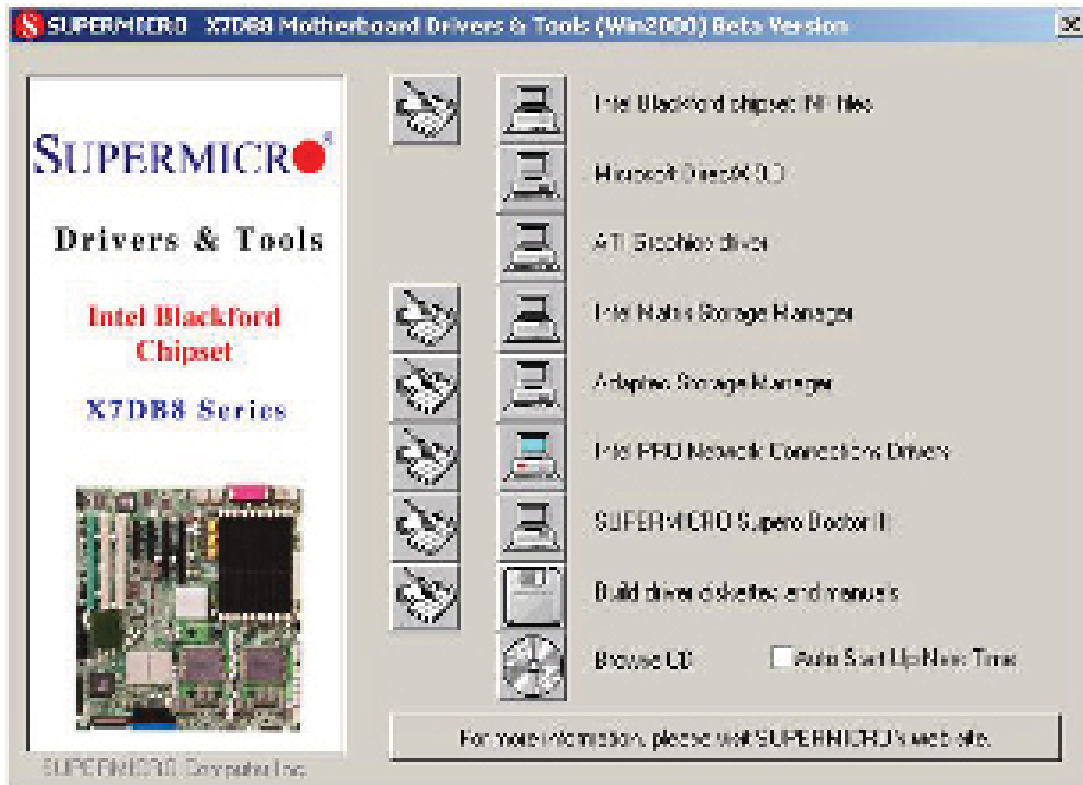

Figure C-1. Driver/Tool Installation Display Screen

**Note:** Click the icons showing a hand writing on paper to view the readme files for each item. Click the computer icons to the right of these items to install each item (from top to the bottom) one at a time. **After installing each item, you must re-boot the system before moving on to the next item on the list.** You should install everything here except for the SUPER Doctor utility and the LAN/SCSI driver diskettes, which are optional. The bottom icon with a CD on it allows you to view the entire contents of the CD.

## Supero Doctor III

The Supero Doctor III program is a Web base management tool that supports remote management capability. It includes Remote and Local Management tools. The local management is called SD III Client. The Supero Doctor III program included on the CDROM that came with your motherboard allows you to monitor the environment and operations of your system. Supero Doctor III displays crucial system information such as CPU temperature, system voltages and fan status. See the Figure below for a display of the Supero Doctor III interface.

**Note:** The default User Name and Password for SuperDoctor III is ADMIN / ADMIN.

**Note:** When SuperDoctor III is first installed, it adopts the temperature threshold settings that have been set in BIOS. Any subsequent changes to these thresholds must be made within Super Doctor, as the Super Doctor settings override the BIOS settings. To set the BIOS temperature threshold settings again, you would first need to uninstall SuperDoctor III.

Figure C-2. Supero Doctor III: Health Information

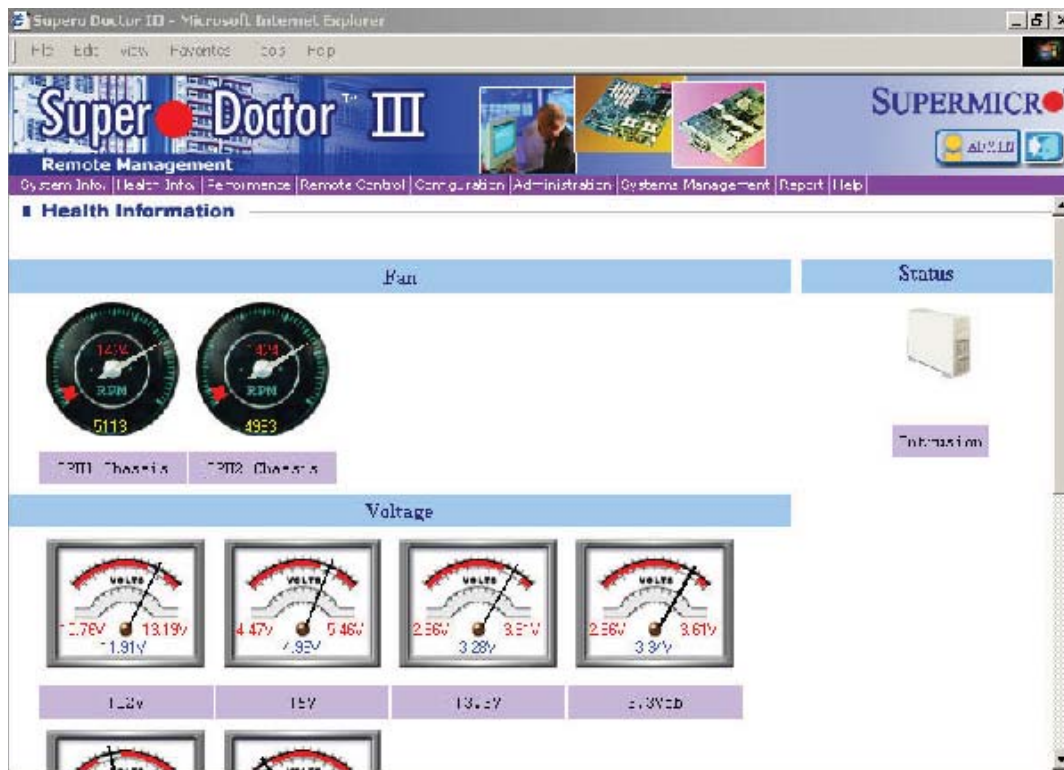

Figure C-3. Supero Doctor III Display: Remote Control



Note: SD III Software Revision 1.0 can be downloaded from our Web Site at: [ftp://ftp.supermicro.com/utility/Supero\\_Doctor\\_III/](ftp://ftp.supermicro.com/utility/Supero_Doctor_III/). You can also download SDIII User's Guide at: <http://www.supermicro.com/PRODUCT/Manuals/SDIII/UserGuide.pdf>. For Linux, we will still recommend Supero Doctor II.

**Notes**

## Appendix D

# System Specifications

### Processors

Single or dual Intel® Xeon™ LGA 771 type processors at a front side (system) bus speed of 1333 MHz.

**Note:** Please refer to our web site for a complete listing of supported processors.

### Chipset

Intel 5000P/ESB2 chipset

### BIOS

8 Mb Phoenix® Flash ROM

### Memory Capacity

Sixteen 240-pin DIMM sockets supporting up to 64 GB of FBD ECC DDR2-667/533 SDRAM

**Note:** 4-way interleaved memory - requires memory to be installed four modules at a time. See the memory section in Chapter 5 for details.

### Dual-Channel SCSI Controller (6025B-8R+ only)

Adaptec AIC-7902W dual-channel controller for U320 SCSI (RAID 0, 1 5 and 10 supported)

### SATA Controller

Intel on-chip (ESB2) controller for 6-port SATA 3 Gb/s (RAID 0, 1 supported)

### SCSI/SATA Drive Bays

Eight (8) hot-swap drive bays to house eight (8) standard SCSI or six (6) standard SATA drives

### Peripheral Drive Bays

One (1) slim DVD-ROM drive

### Expansion Slots

Two x8 PCI-Express slots, one x4 PCI-Express slot, two 64-bit 133 MHz PCI-X slots and one 64-bit 100 MHz PCI-X slot (supports ZCR, 6025B-8R+ only)

### **Serverboard**

6025B-TR+: X7DBE+ (Extended ATX form factor)

6025B-8R+: X7DB8+ (Extended ATX form factor)

Dimensions: 13.5 x 13.05 in (343 x 332 mm)

### **Chassis**

6025B-TR+: SC825TQ-R700LP, 2U rackmount

6025B-8R+: SC825S2-R700LP, 2U rackmount

Dimensions (both): (WxHxD) 16.8 x 3.5 x 25.5 in. (427 x 89 x 648 mm)

### **Weight**

Gross (Bare Bone): 57 lbs. (25.9 kg.)

### **System Cooling**

Three (3) 8-cm system cooling fans

### **System Input Requirements**

AC Input Voltage: 100-240V AC auto-range

Rated Input Current: 9.5A - 4.5A

Rated Input Frequency: 50 to 60 Hz

### **Power Supply**

Rated Output Power: 700W (Model# SP801-1R, Part# PWS-702A-1R)

Rated Output Voltages: +12V (58A), +5Vsb (4A)

### **BTU Rating**

3431 BTUs/hr (for rated output power of 700W)

### **Operating Environment**

Operating Temperature: 10° to 35° C (50° to 95° F)

Non-operating Temperature: -40° to 70° C (-40° to 158° F)

Operating Relative Humidity: 8% to 90% (non-condensing)

Non-operating Relative Humidity: 5 to 95% (non-condensing)

## **Regulatory Compliance**

### Electromagnetic Emissions:

FCC Class A, EN 55022 Class A, EN 61000-3-2/-3-3, CISPR 22 Class A

### Electromagnetic Immunity:

EN 55024/CISPR 24, (EN 61000-4-2, EN 61000-4-3, EN 61000-4-4,  
EN 61000-4-5, EN 61000-4-6, EN 61000-4-8, EN 61000-4-11)

### Safety:

EN 60950/IEC 60950-Compliant, UL Listed (USA), CUL Listed (Canada), TUV  
Certified (Germany), CE Marking (Europe)

### California Best Management Practices Regulations for Perchlorate Materials:

This Perchlorate warning applies only to products containing CR (Manganese Dioxide) Lithium coin cells. "Perchlorate Material-special handling may apply. See [www.dtsc.ca.gov/hazardouswaste/perchlorate](http://www.dtsc.ca.gov/hazardouswaste/perchlorate)"

(continued from front)

The products sold by Supermicro are not intended for and will not be used in life support systems, medical equipment, nuclear facilities or systems, aircraft, aircraft devices, aircraft/emergency communication devices or other critical systems whose failure to perform be reasonably expected to result in significant injury or loss of life or catastrophic property damage. Accordingly, Supermicro disclaims any and all liability, and should buyer use or sell such products for use in such ultra-hazardous applications, it does so entirely at its own risk. Furthermore, buyer agrees to fully indemnify, defend and hold Supermicro harmless for and against any and all claims, demands, actions, litigation, and proceedings of any kind arising out of or related to such ultra-hazardous use or sale.