

# SUPERO<sup>®</sup>

## SUPERSERVER 8025C-3R

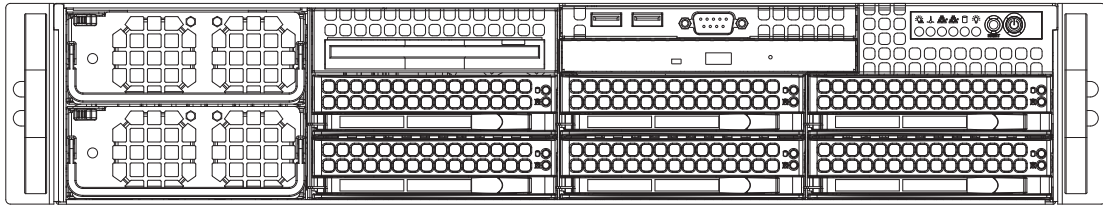

## USER'S MANUAL

Revision 1.0a

---

The information in this User's Manual has been carefully reviewed and is believed to be accurate. The vendor assumes no responsibility for any inaccuracies that may be contained in this document, makes no commitment to update or to keep current the information in this manual, or to notify any person or organization of the updates. **Please Note: For the most up-to-date version of this manual, please see our web site at [www.supermicro.com](http://www.supermicro.com).**

Super Micro Computer, Inc. ("Supermicro") reserves the right to make changes to the product described in this manual at any time and without notice. This product, including software, if any, and documentation may not, in whole or in part, be copied, photocopied, reproduced, translated or reduced to any medium or machine without prior written consent.

IN NO EVENT WILL SUPERMICRO BE LIABLE FOR DIRECT, INDIRECT, SPECIAL, INCIDENTAL, SPECULATIVE OR CONSEQUENTIAL DAMAGES ARISING FROM THE USE OR INABILITY TO USE THIS PRODUCT OR DOCUMENTATION, EVEN IF ADVISED OF THE POSSIBILITY OF SUCH DAMAGES. IN PARTICULAR, SUPERMICRO SHALL NOT HAVE LIABILITY FOR ANY HARDWARE, SOFTWARE, OR DATA STORED OR USED WITH THE PRODUCT, INCLUDING THE COSTS OF REPAIRING, REPLACING, INTEGRATING, INSTALLING OR RECOVERING SUCH HARDWARE, SOFTWARE, OR DATA.

Any disputes arising between manufacturer and customer shall be governed by the laws of Santa Clara County in the State of California, USA. The State of California, County of Santa Clara shall be the exclusive venue for the resolution of any such disputes. Super Micro's total liability for all claims will not exceed the price paid for the hardware product.

FCC Statement: This equipment has been tested and found to comply with the limits for a Class A digital device pursuant to Part 15 of the FCC Rules. These limits are designed to provide reasonable protection against harmful interference when the equipment is operated in a commercial environment. This equipment generates, uses, and can radiate radio frequency energy and, if not installed and used in accordance with the manufacturer's instruction manual, may cause harmful interference with radio communications. Operation of this equipment in a residential area is likely to cause harmful interference, in which case you will be required to correct the interference at your own expense.

California Best Management Practices Regulations for Perchlorate Materials: This Perchlorate warning applies only to products containing CR (Manganese Dioxide) Lithium coin cells. "Perchlorate Material-special handling may apply. See [www.dtsc.ca.gov/hazardouswaste/perchlorate](http://www.dtsc.ca.gov/hazardouswaste/perchlorate)"

---

**WARNING: Handling of lead solder materials used in this product may expose you to lead, a chemical known to the State of California to cause birth defects and other reproductive harm.**

---

Manual Revision 1.0a  
Release Date: December 24, 2008

Unless you request and receive written permission from Super Micro Computer, Inc., you may not copy any part of this document.

Information in this document is subject to change without notice. Other products and companies referred to herein are trademarks or registered trademarks of their respective companies or mark holders.

Copyright © 2008 by Super Micro Computer, Inc.  
All rights reserved.

**Printed in the United States of America**

# Preface

## About This Manual

This manual is written for professional system integrators and PC technicians. It provides information for the installation and use of the SuperServer 8025C-3R. Installation and maintenance should be performed by experienced technicians only.

The SuperServer 8025C-3R is a high-end quad processor server based on the SC828TQ-R1200 2U rackmount server chassis and the Super X7QC3 serverboard. The X7QC3 supports four Intel® Xeon MP processors. Please refer to our web site for an up-to-date list of supported processors.

## Manual Organization

### Chapter 1: Introduction

The first chapter provides a checklist of the main components included with the server system and describes the main features of the Super X7QC3 serverboard and the SC828TQ-R1200 chassis.

### Chapter 2: Server Installation

This chapter describes the steps necessary to install the SuperServer 8025C-3R into a rack and check out the server configuration prior to powering up the system. If your server was ordered without the processor and memory components, this chapter will refer you to the appropriate sections of the manual for their installation.

### Chapter 3: System Interface

Refer to this chapter for details on the system interface, which includes the functions and information provided by the control panel on the chassis as well as other LEDs located throughout the system.

### Chapter 4: System Safety

You should thoroughly familiarize yourself with this chapter for a general overview of safety precautions that should be followed when installing and servicing the SuperServer 8025C-3R.

## **Chapter 5: Advanced Serverboard Setup**

Chapter 5 provides detailed information on the X7QC3 serverboard, including the locations and functions of connectors, headers and jumpers. Refer to this chapter when adding or removing processors or main memory and when reconfiguring the serverboard.

## **Chapter 6: Advanced Chassis Setup**

Refer to Chapter 6 for detailed information on the SC828TQ-R1200 2U rackmount server chassis. You should follow the procedures given in this chapter when installing, removing or reconfiguring SAS or peripheral drives and when replacing system power supply units and cooling fans.

## **Chapter 7: BIOS**

The BIOS chapter includes an introduction to BIOS and provides detailed information on running the CMOS Setup Utility.

## **Appendix A: BIOS POST Messages**

## **Appendix B: BIOS POST Codes**

## **Appendix C: HostRAID Setup Guidelines**

## **Appendix D: System Specifications**

## Notes

---



---

# Table of Contents

## **Chapter 1 Introduction**

1-1	Overview .....	1-1
1-2	Serverboard Features .....	1-2
	Processors .....	1-2
	Memory .....	1-2
	Serial Attached SCSI (SAS) .....	1-2
	Serial ATA (SATA) .....	1-2
	PCI Expansion Slots .....	1-2
	Onboard Controllers/Ports .....	1-3
	ATI Graphics Controller.....	1-3
	IPMI.....	1-3
	Other Features .....	1-3
1-3	Server Chassis Features .....	1-4
	System Power .....	1-4
	SAS Subsystem .....	1-4
	Front Control Panel.....	1-4
	I/O Backplane.....	1-4
	Cooling System .....	1-4
1-4	Contacting Supermicro.....	1-6

## **Chapter 2 Server Installation**

2-1	Overview .....	2-1
2-2	Unpacking the System .....	2-1
2-3	Preparing for Setup.....	2-1
	Choosing a Setup Location.....	2-2
	Rack Precautions .....	2-2
	Server Precautions.....	2-2
	Rack Mounting Considerations .....	2-3
	Ambient Operating Temperature .....	2-3
	Reduced Airflow .....	2-3
	Mechanical Loading .....	2-3
	Circuit Overloading.....	2-3
	Reliable Ground .....	2-3
2-4	Installing the System into a Rack .....	2-4
	Identifying the Sections of the Rack Rails.....	2-4
	Installing the Inner Rails .....	2-4
	Installing the Outer Rails.....	2-4

---

Locking Tabs .....	2-4
Installing the Server into the Rack.....	2-5
2-5 Checking the Serverboard Setup.....	2-6
2-6 Preparing to Power On .....	2-7
<b>Chapter 3 System Interface</b>	
3-1 Overview .....	3-1
3-2 Control Panel Buttons .....	3-1
Reset.....	3-1
Power .....	3-1
3-3 Control Panel LEDs .....	3-2
Power Fail .....	3-2
Overheat/Fan Fail .....	3-2
NIC2 .....	3-2
NIC1 .....	3-2
HDD.....	3-3
Power .....	3-3
3-4 SAS Drive Carrier LEDs .....	3-3
<b>Chapter 4 System Safety</b>	
4-1 Electrical Safety Precautions .....	4-1
4-2 General Safety Precautions .....	4-2
4-3 ESD Precautions.....	4-3
4-4 Operating Precautions .....	4-4
<b>Chapter 5 Advanced Serverboard Setup</b>	
5-1 Handling the Serverboard .....	5-1
Precautions .....	5-1
Unpacking .....	5-2
5-2 Serverboard Installation .....	5-2
5-3 Connecting Cables.....	5-3
Connecting Data Cables .....	5-3
Connecting Power Cables .....	5-3
Connecting the Control Panel.....	5-3
5-4 I/O Ports .....	5-4
5-5 Installing the Processor and Heatsink .....	5-5
5-6 Installing Memory .....	5-8
Memory Support.....	5-8
5-7 Adding PCI Add-On Cards.....	5-9
5-8 Serverboard Details .....	5-10
X7QC3 Quick Reference .....	5-11

---

5-9	Connector Definitions .....	5-12
5-10	Jumper Settings .....	5-18
5-11	Onboard Indicators.....	5-22
5-12	Floppy, IDE, and SAS Ports.....	5-23

**Chapter 6 Advanced Chassis Setup**

6-1	Static-Sensitive Devices.....	6-1
	Precautions .....	6-1
6-2	Control Panel .....	6-2
	Unpacking .....	6-2
6-3	System Fans .....	6-3
	System Fan Failure.....	6-3
	Replacing System Fans.....	6-3
6-4	Drive Bay Installation/Removal.....	6-4
	Accessing the Drive Bays .....	6-4
	SAS Drive Installation .....	6-5
	SAS Drive Backplane.....	6-7
6-5	Power Supply .....	6-8
	Power Supply Failure.....	6-8
	Removing/Replacing the Power Supply.....	6-8

**Chapter 7 BIOS**

7-1	Introduction.....	7-1
	Starting BIOS Setup Utility.....	7-1
7-2	Main Setup .....	7-2
7-3	Advanced Settings .....	7-3
7-5	Security Settings .....	7-23
7-6	Exit Options.....	7-24

**Appendix A BIOS POST Messages**

**Appendix B BIOS POST Codes**

**Appendix C HostRAID Setup Guidelines**

**Appendix D System Specifications**

# Chapter 1

## Introduction

### 1-1 Overview

The SuperServer 8025C-3R is a high-end server that is comprised of two main subsystems: the SC828TQ-R1200 2U server chassis and the X7QC3 quad Intel Xeon processor serverboard. Please refer to our web site for information on operating systems that have been certified for use with the SuperServer 8025C-3R ([www.supermicro.com](http://www.supermicro.com)).

In addition to the serverboard and chassis, various hardware components have been included with the SuperServer 8025C-3R, as listed below:

- Six (6) 8-cm hot-swap chassis fans (FAN-0099L)
- One (1) air shroud (MCP-310-82801-0N)
- One (1) air shroud (MCP-310-00032-00)
- One (1) slim DVD-ROM drive (DVM-PNSC-824B)
- One (1) IDE cable for DVD drive (CBL-0139L)
- One (1) rail set (MCP-290-00013-00)
- One (1) Super Server 8025C-3R User's Manual
- SAS Accessories
  - One (1) SAS backplane (BPN-SAS-828TQ)
  - Two (2) SAS iPass cables (CBL-0188L)
  - Six (6) hot-swap drive carriers (MCP-220-00001-01)

## 1-2 Serverboard Features

At the heart of the SuperServer 8025C-3R lies the X7QC3, a quad processor serverboard based on the Intel 7300 chipset. Below are the main features of the X7QC3. (See Figure 1-1 for a block diagram of the 7300 chipset).

### Processors

The X7QC3 supports four Intel Xeon MP 7300/7200 Series processors. Please refer to the serverboard description pages on our web site for a complete listing of supported processors ([www.supermicro.com](http://www.supermicro.com)).

### Memory

The X7QC3 has 24 240-pin DIMM slots that can support up to 192 GB of ECC FBD (Fully Buffered DIMM) DDR2-667/533 SDRAM. Single channel, two-channel interleaved and four-channel interleaved memory are all supported. Modules of the same size and speed should be used. See Chapter 5 Section 5 for details.

### Serial Attached SCSI (SAS)

An onboard LSI-1068E Serial Attached SCSI (SAS) controller is integrated into the X7QC3, which supports eight SAS hard drives with SES2. The SAS drives are connected to a backplane that provides power, bus termination and configuration settings and are hot-swappable units. **Note:** The operating system you use must have RAID support to enable the hot-swap capability and RAID function of the SAS drives. RAID 0, 1 and 10 are supported. (RAID 5 is also supported with an optional i-Button installed.)

### Serial ATA (SATA)

A SATA controller is integrated into the South Bridge (ESB2E) section of the chipset to provide a six-port Serial ATA subsystem, which is RAID 0, 1, 10 and 5 supported. The Serial ATA drives are hot-swappable units.

### PCI Expansion Slots

The X7QC3 has two PCI-Express x8 slots, one PCI-Express x4 slot and one PCI-X 133 MHz slot. Only low-profile cards are supported.

## **Onboard Controllers/Ports**

One floppy drive controller and an onboard ATA/100 controller are provided to support up to two IDE hard drives or ATAPI devices (one IDE connection is reserved for a Compact Flash card). The color-coded I/O ports include one COM port (an additional COM header is located on the serverboard), a VGA (monitor) port, two USB 2.0 ports, PS/2 mouse and keyboard ports and two Gb Ethernet ports.

## **ATI Graphics Controller**

The X7QC3 features an integrated ATI video controller based on the ES1000 graphics chip. The ES1000 was designed specifically for servers, featuring low power consumption, high reliability and superior longevity.

## **IPMI**

IPMI (Intelligent Platform Management Interface) is a hardware-level interface specification that provides remote access, monitoring and administration for Supermicro server platforms. IPMI allows server administrators to view a server's hardware status remotely, receive an alarm automatically if a failure occurs, and power cycle a system that is non-responsive. Optional add-on cards for IPMI use include the AOC-SIMSO and the AOC-SIMSO+. An optional cable (CBL-0177L) must be used for dedicated LAN. Please refer to our web page for the X7QC3 for more details.

## **Other Features**

Other onboard features that promote system health include onboard voltage monitors, a chassis intrusion header, auto-switching voltage regulators, chassis and CPU overheat sensors, virus protection and BIOS rescue.

## 1-3 Server Chassis Features

The following is a general outline of the main features of the SC828TQ-R1200 server chassis.

### **System Power**

The SC828TQ-R1200 features a redundant (two separate power modules) 1200W high-efficiency power supply with I<sup>2</sup>C. This power redundancy feature allows you to replace a failed power supply without shutting down the system.

### **SAS Subsystem**

The SC828TQ-R1200 chassis was designed to support six hot-swappable SAS hard drives.

### **Front Control Panel**

The control panel on the SuperServer 8025C-3R provides you with system monitoring and control. LEDs indicate system power, HDD activity, network activity, system overheat and power supply failure. A main power button and a system reset button are also included. In addition, two USB ports and a COM port have been incorporated into the front of the chassis for convenient access.

### **I/O Backplane**

The SC828TQ-R1200 is an ATX form factor chassis designed to be used in a 2U rackmount configuration. The I/O backplane includes one COM port, a VGA port, two USB 2.0 ports, PS/2 mouse and keyboard ports and two gigabit Ethernet ports. One standard size PCI expansion card may be added to the system.

### **Cooling System**

The SC828TQ-R1200 chassis has an innovative cooling design that includes six 4-cm counter-rotating fans located in the middle section of the chassis. The power supply module also includes a cooling fan. All chassis and power supply fans operate continuously. An air shroud channels the airflow from the system fans to efficiently cool the processors and memory.

**Figure 1-1. Intel 7300 Chipset:  
System Block Diagram**

**Note:** This is a general block diagram. See Chapter 5 for details.

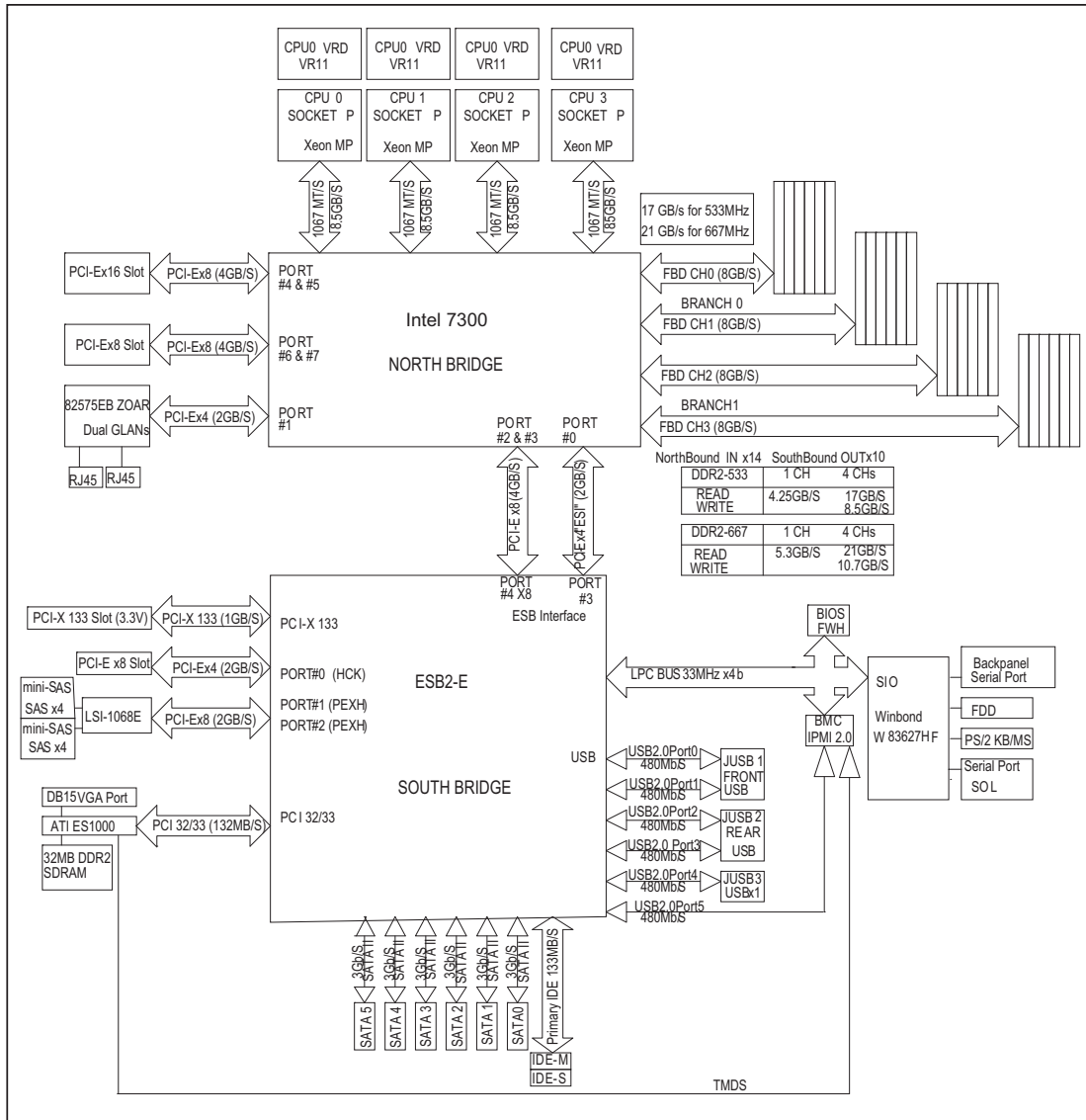

## 1-4 Contacting Supermicro

### Headquarters

Address: Super Micro Computer, Inc.  
980 Rock Ave.  
San Jose, CA 95131 U.S.A.

Tel: +1 (408) 503-8000

Fax: +1 (408) 503-8008

Email: marketing@supermicro.com (General Information)  
support@supermicro.com (Technical Support)

Web Site: www.supermicro.com

### Europe

Address: Super Micro Computer B.V.  
Het Sterrenbeeld 28, 5215 ML  
's-Hertogenbosch, The Netherlands

Tel: +31 (0) 73-6400390

Fax: +31 (0) 73-6416525

Email: sales@supermicro.nl (General Information)  
support@supermicro.nl (Technical Support)  
rma@supermicro.nl (Customer Support)

### Asia-Pacific

Address: Super Micro Computer, Inc.  
4F, No. 232-1, Liancheng Rd.  
Chung-Ho 235, Taipei County  
Taiwan, R.O.C.

Tel: +886-(2) 8226-3990

Fax: +886-(2) 8226-3991

Web Site: www.supermicro.com.tw

Technical Support:

Email: support@supermicro.com.tw

Tel: 886-2-8228-1366, ext.132 or 139

# Chapter 2

## Server Installation

### 2-1 Overview

This chapter provides a quick setup checklist to get your 8025C-3R up and running. Following these steps in the order given should enable you to have the system operational within a minimum amount of time. This quick setup assumes that your system has come to you with the processors and memory preinstalled. If your system is not already fully integrated with a serverboard, processors, system memory etc., please turn to the chapter or section noted in each step for details on installing specific components.

### 2-2 Unpacking the System

You should inspect the box the 8025C-3R was shipped in and note if it was damaged in any way. If the server itself shows damage you should file a damage claim with the carrier who delivered it.

Decide on a suitable location for the rack unit that will hold the 8025C-3R. It should be situated in a clean, dust-free area that is well ventilated. Avoid areas where heat, electrical noise and electromagnetic fields are generated. You will also need it placed near a grounded power outlet. Be sure to read the Rack and Server Precautions in the next section.

### 2-3 Preparing for Setup

The box the 8025C-3R was shipped in should include two sets of rail assemblies, two rail mounting brackets and the mounting screws you will need to install the system into the rack. Follow the steps in the order given to complete the installation process in a minimum amount of time. Please read this section in its entirety before you begin the installation procedure outlined in the sections that follow.

## Choosing a Setup Location

- Leave enough clearance in front of the rack to enable you to open the front door completely (~25 inches) and approximately 30 inches of clearance in the back of the rack to allow for sufficient airflow and ease in servicing.
- This product is for installation only in a Restricted Access Location (dedicated equipment rooms, service closets and the like).
- This product is not suitable for use with visual display work place devices according to §2 of the the German Ordinance for Work with Visual Display Units.



## Warnings and Precautions!



### Rack Precautions

- Ensure that the leveling jacks on the bottom of the rack are fully extended to the floor with the full weight of the rack resting on them.
- In single rack installation, stabilizers should be attached to the rack. In multiple rack installations, the racks should be coupled together.
- Always make sure the rack is stable before extending a component from the rack.
- You should extend only one component at a time - extending two or more simultaneously may cause the rack to become unstable.

### Server Precautions

- Review the electrical and general safety precautions in Chapter 4.
- Determine the placement of each component in the rack *before* you install the rails.
- Install the heaviest server components on the bottom of the rack first, and then work up.
- Use a regulating uninterruptible power supply (UPS) to protect the server from power surges, voltage spikes and to keep your system operating in case of a power failure.

- Allow the hot plug SAS drives and power supply modules to cool before touching them.
- Always keep the rack's front door and all panels and components on the servers closed when not servicing to maintain proper cooling.

## **Rack Mounting Considerations**

### ***Ambient Operating Temperature***

If installed in a closed or multi-unit rack assembly, the ambient operating temperature of the rack environment may be greater than the ambient temperature of the room. Therefore, consideration should be given to installing the equipment in an environment compatible with the manufacturer's maximum rated ambient temperature (T<sub>mra</sub>).

### ***Reduced Airflow***

Equipment should be mounted into a rack so that the amount of airflow required for safe operation is not compromised.

### ***Mechanical Loading***

Equipment should be mounted into a rack so that a hazardous condition does not arise due to uneven mechanical loading.

### ***Circuit Overloading***

Consideration should be given to the connection of the equipment to the power supply circuitry and the effect that any possible overloading of circuits might have on overcurrent protection and power supply wiring. Appropriate consideration of equipment nameplate ratings should be used when addressing this concern.

### ***Reliable Ground***

A reliable ground must be maintained at all times. To ensure this, the rack itself should be grounded. Particular attention should be given to power supply connections other than the direct connections to the branch circuit (i.e. the use of power strips, etc.).

## 2-4 Installing the System into a Rack

This section provides information on installing the 8025C-3R into a rack unit with the rack rails provided. If the system has already been mounted into a rack, you can skip ahead to Sections 2-5 and 2-6. There are a variety of rack units on the market, which may mean the assembly procedure will differ slightly. You should also refer to the installation instructions that came with the rack unit you are using.

### Identifying the Sections of the Rack Rails

You should have received two rack rail assemblies in the rack mounting kit. Each assembly consists of two sections: an inner fixed chassis rail that secures directly to the server chassis and an outer fixed rack rail that secures directly to the rack itself. Two pairs of short brackets to be used on the front side of the outer rails are also included.

### Installing the Inner Rails

Both the left and right side inner rails have been pre-attached to the chassis. Proceed to the next step.

### Installing the Outer Rails

Begin by measuring the distance from the front rail to the rear rail of the rack. Attach a short bracket to the front side of the right outer rail and a long bracket to the rear side of the right outer rail. Adjust both the short and long brackets to the proper distance so that the rail can fit snugly into the rack. Secure the short bracket to the front side of the outer rail with two M4 screws and the long bracket to the rear side of the outer rail with three M4 screws. Repeat these steps for the left outer rail.

### *Locking Tabs*

Both chassis rails have a locking tab, which serves two functions. The first is to lock the server into place when installed and pushed fully into the rack, which is its normal position. Secondly, these tabs also lock the server in place when fully extended from the rack. This prevents the server from coming completely out of the rack when you pull it out for servicing.

## Installing the Server into the Rack

You should now have rails attached to both the chassis and the rack unit. The next step is to install the server into the rack. Do this by lining up the rear of the chassis rails with the front of the rack rails. Slide the chassis rails into the rack rails, keeping the pressure even on both sides (you may have to depress the locking tabs when inserting). See Figure 2-1.

When the server has been pushed completely into the rack, you should hear the locking tabs "click". Finish by inserting and tightening the thumbscrews that hold the front of the server to the rack.

**Figure 2-1. Installing the Server into a Rack**

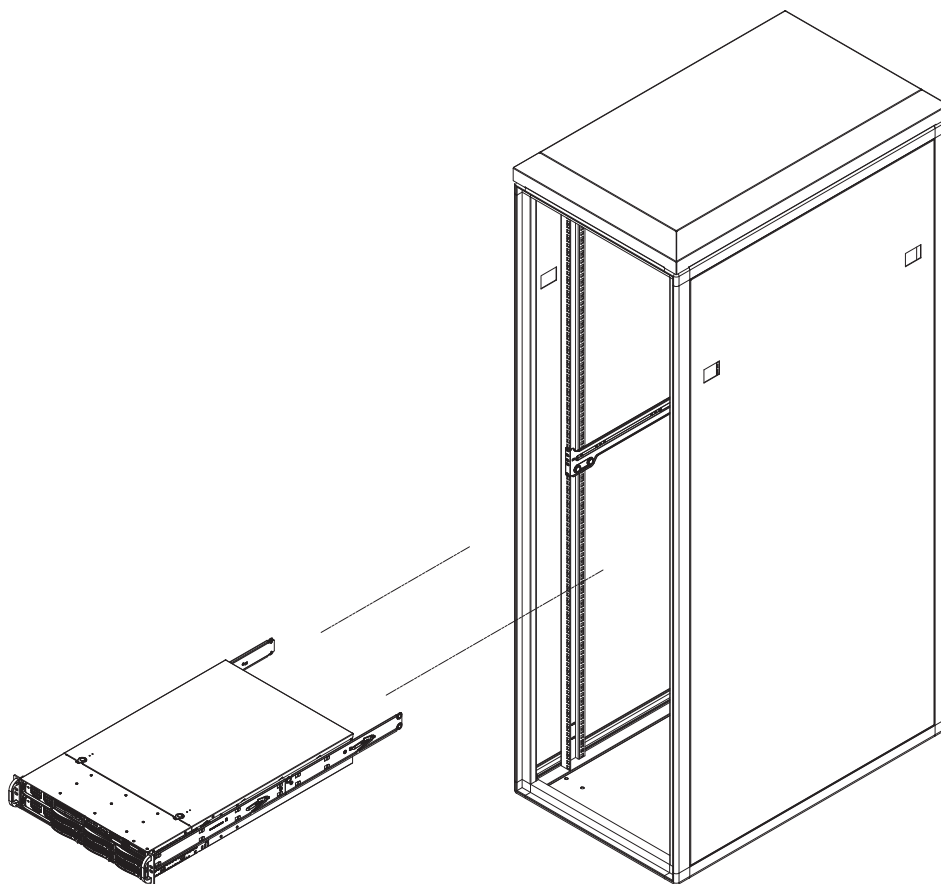

## 2-5 Checking the Serverboard Setup

After you install the 8025C-3R in the rack, you will need to open the top cover to make sure the serverboard is properly installed and all the connections have been made.

### ***Accessing the Inside of the System***

1. First, release the retention screws that secure the system to the rack.
2. Grasp the two handles on either side and pull the system straight out until it locks (you will hear a "click").
3. Next, release the thumbscrew at the middle rear of the top cover. Then depress the two buttons on the top of the chassis to release the top cover.
4. Push the cover away from you (toward the rear of the chassis) until it stops. You can then lift the top cover from the chassis to gain full access to the inside of the server.
5. To remove the system from the rack completely, depress the locking tabs in the chassis rails (push the right-side tab down and the left-side tab up) to continue to pull the system out past the locked position.

### ***Checking the Components and Setup***

1. You may up to four processors already installed in the serverboard. Each processor needs its own heatsink. See Chapter 5 for instructions on processor and heatsink installation.
2. Your server system may have come with system memory already installed. Make sure all DIMMs are fully seated in their slots. For details on adding system memory, refer to Chapter 5.
3. If desired, you can install an add-on card to the system. See Chapter 5 for details on installing PCI add-on cards.
4. Make sure all power and data cables are properly connected and not blocking the chassis airflow. See Chapter 5 for details on cable connections.

## 2-6 Preparing to Power On

Next, you should check to make sure the peripheral drives and the SAS drives and SAS backplane have been properly installed and all connections have been made.

### ***Checking the Drives***

1. All drives are accessible from the front of the server. For servicing the DVD-ROM and floppy drives, you will need to remove the top chassis cover. The SAS disk drives can be installed and removed from the front of the chassis without removing the top chassis cover.
2. A slim DVD-ROM and floppy drive should be preinstalled in your server. Refer to Chapter 6 if you need to reinstall a DVD-ROM and/or floppy disk drive to the system.
3. Depending upon your system's configuration, your system may have one or more drives already installed. If you need to install SAS drives, please refer to Chapter 6.

### ***Checking the Airflow***

1. Airflow is provided by six sets of 4-cm fans (each set of fans consists of two fans that are mounted back to back) and an air shroud. The system component layout was carefully designed to direct sufficient cooling airflow to the components that generate the most heat.
2. Note that all power and data cables have been routed in such a way that they do not block the airflow generated by the fans.

### ***Providing Power***

1. Plug the power cords from the power supplies unit into a high-quality power strip that offers protection from electrical noise and power surges.
2. It is recommended that you use an uninterruptible power supply (UPS).
3. Finally, depress the power on button on the front of the chassis.

**Notes**

# Chapter 3

## System Interface

### 3-1 Overview

There are several LEDs on the control panel as well as others on the SAS drive carriers to keep you constantly informed of the overall status of the system as well as the activity and health of specific components. There are also two buttons on the chassis control panel and an on/off switch on the power supply. This chapter explains the meanings of all LED indicators and the appropriate response you may need to take.

### 3-2 Control Panel Buttons

There are two push-buttons located on the front of the chassis: a reset button and a power on/off button.



#### **Reset**

Use the reset button to reboot the system.



#### **Power**

The main power button is used to apply or remove power from the power supply to the server system. Turning off system power with this button removes the main power but keeps standby power supplied to the system.

### 3-3 Control Panel LEDs

The control panel located on the front of the SC828TQ-R1200 chassis has five LEDs. These LEDs provide you with critical information related to different parts of the system. This section explains what each LED indicates when illuminated and any corrective action you may need to take.



#### Power Fail

Indicates a power supply module has failed. The second power supply module will take the load and keep the system running but the failed module will need to be replaced. Refer to Chapter 6 for details on replacing the power supply. This LED should be off when the system is operating normally



#### Overheat/Fan Fail

When this LED flashes it indicates a fan failure. When on continuously (on and not flashing) it indicates an overheat condition, which may be caused by cables obstructing the airflow in the system or the ambient room temperature being too warm. Check the routing of the cables and make sure all fans are present and operating normally. You should also check to make sure that the chassis covers are installed. Finally, verify that the heatsinks are installed properly (see Chapter 5). This LED will remain flashing or on as long as the overheat condition exists.



#### NIC2

Indicates network activity on GLAN2 when flashing.



#### NIC1

Indicates network activity on GLAN1 when flashing.



### **HDD**

Indicates IDE channel activity. On the 8025C-3R this light indicates SAS and/or DVD-ROM drive activity when flashing.



### **Power**

Indicates power is being supplied to the system's power supply units. This LED should normally be illuminated when the system is operating.

## **3-4 SAS Drive Carrier LEDs**

Each SAS drive carrier has two LEDs:

- **Green:** When illuminated, the green LED on the front of the SAS drive carrier indicates drive activity. A connection to the backplane enables this LED to blink on and off when that particular drive is being accessed.
- **Red:** The SES2 compliant backplane activates the red LED to indicate a drive failure. If one of the SAS drives fail, you should be notified by your system management software. Please refer to Chapter 6 for instructions on replacing failed SAS drives.

**Notes**

# Chapter 4

## System Safety

### 4-1 Electrical Safety Precautions



Basic electrical safety precautions should be followed to protect yourself from harm and the SuperServer 8025C-3R from damage:

- Be aware of the locations of the power on/off switch on the chassis as well as the room's emergency power-off switch, disconnection switch or electrical outlet. If an electrical accident occurs, you can then quickly remove power from the system.
- Do not work alone when working with high voltage components.
- Power should always be disconnected from the system when removing or installing main system components, such as the serverboard, memory modules and floppy drive. When disconnecting power, you should first power down the system with the operating system first and then unplug the power cords of all the power supply units in the system.
- When working around exposed electrical circuits, another person who is familiar with the power-off controls should be nearby to switch off the power if necessary.
- Use only one hand when working with powered-on electrical equipment. This is to avoid making a complete circuit, which will cause electrical shock. Use extreme caution when using metal tools, which can easily damage any electrical components or circuit boards they come into contact with.
- Do not use mats designed to decrease static electrical discharge as protection from electrical shock. Instead, use rubber mats that have been specifically designed as electrical insulators.
- The power supply power cords must include a grounding plug and must be plugged into grounded electrical outlets.

- Serverboard Battery: **CAUTION** - There is a danger of explosion if the onboard battery is installed upside down, which will reverse its polarities (see Figure 4-1). This battery must be replaced only with the same or an equivalent type recommended by the manufacturer. Dispose of used batteries according to the manufacturer's instructions.
- CD-ROM Laser: **CAUTION** - this server may have come equipped with a CD-ROM drive. To prevent direct exposure to the laser beam and hazardous radiation exposure, do not open the enclosure or use the unit in any unconventional way.
- Mainboard replaceable soldered-in fuses: Self-resetting PTC (Positive Temperature Coefficient) fuses on the mainboard must be replaced by trained service technicians only. The new fuse must be the same or equivalent as the one replaced. Contact technical support for details and support.

## 4-2 General Safety Precautions



Follow these rules to ensure general safety:

- Keep the area around the SuperServer 8025C-3R clean and free of clutter.
- The SuperServer 8025C-3R weighs approximately 65.5 lbs. (29.8 kg) when fully loaded. When lifting the system, two people at either end should lift slowly with their feet spread out to distribute the weight. Always keep your back straight and lift with your legs.
- Place the chassis top cover and any system components that have been removed away from the system or on a table so that they won't accidentally be stepped on.
- While working on the system, do not wear loose clothing such as neckties and unbuttoned shirt sleeves, which can come into contact with electrical circuits or be pulled into a cooling fan.
- Remove any jewelry or metal objects from your body, which are excellent metal conductors that can create short circuits and harm you if they come into contact with printed circuit boards or areas where power is present.

- After accessing the inside of the system, close the system back up and secure it to the rack unit with the retention screws after ensuring that all connections have been made.

### 4-3 ESD Precautions



Electrostatic discharge (ESD) is generated by two objects with different electrical charges coming into contact with each other. An electrical discharge is created to neutralize this difference, which can damage electronic components and printed circuit boards. The following measures are generally sufficient to neutralize this difference before contact is made to protect your equipment from ESD:

- Use a grounded wrist strap designed to prevent static discharge.
- Keep all components and printed circuit boards (PCBs) in their antistatic bags until ready for use.
- Touch a grounded metal object before removing the board from the antistatic bag.
- Do not let components or PCBs come into contact with your clothing, which may retain a charge even if you are wearing a wrist strap.
- Handle a board by its edges only; do not touch its components, peripheral chips, memory modules or contacts.
- When handling chips or modules, avoid touching their pins.
- Put the serverboard and peripherals back into their antistatic bags when not in use.
- For grounding purposes, make sure your computer chassis provides excellent conductivity between the power supply, the case, the mounting fasteners and the serverboard.

## 4-4 Operating Precautions



Care must be taken to assure that the chassis cover is in place when the 8025C-3R is operating to assure proper cooling. Out of warranty damage to the system can occur if this practice is not strictly followed.

**Figure 4-1. Installing the Onboard Battery**

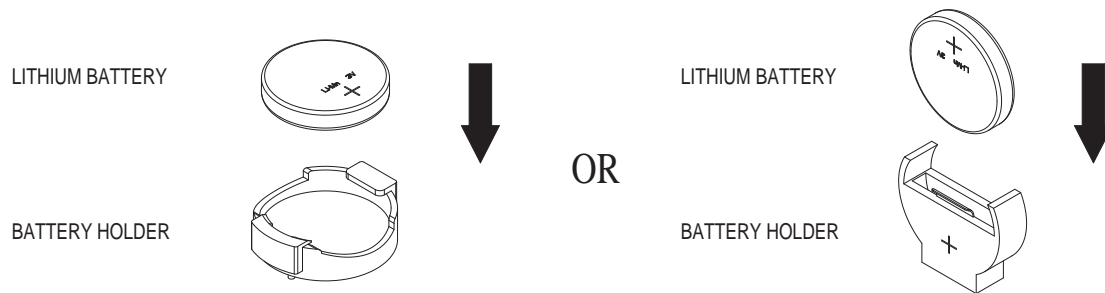

## Chapter 5

# Advanced Serverboard Setup

This chapter covers the steps required to install the X7QC3 serverboard into the chassis, connect the data and power cables and install add-on cards. All serverboard jumpers and connections are also described. A layout and quick reference chart are included in this chapter for your reference. Remember to completely close the chassis when you have finished working with the serverboard to better cool and protect the system.

### 5-1 Handling the Serverboard

Electrostatic discharge (ESD) can damage electronic components. To prevent damage to any printed circuit boards (PCBs), it is important to handle them very carefully (see previous chapter). To prevent the serverboard from bending, keep one hand under the center of the board to support it when handling. The following measures are generally sufficient to protect your equipment from electric static discharge.

#### Precautions

- Use a grounded wrist strap designed to prevent Electrostatic Discharge (ESD).
- Touch a grounded metal object before removing any board from its antistatic bag.
- Handle a board by its edges only; do not touch its components, peripheral chips, memory modules or gold contacts.
- When handling chips or modules, avoid touching their pins.
- Put the serverboard, add-on cards and peripherals back into their antistatic bags when not in use.
- For grounding purposes, make sure your computer chassis provides excellent conductivity between the power supply, the case, the mounting fasteners and the serverboard.

## Unpacking

The serverboard is shipped in antistatic packaging to avoid electrical static discharge. When unpacking the board, make sure the person handling it is static protected.

## 5-2 Serverboard Installation

This section explains the first step of physically mounting the X7QC3 into the SC828TQ-R1200 chassis. Following the steps in the order given will eliminate the most common problems encountered in such an installation. To remove the serverboard, follow the procedure in reverse order.

### *Installing to the Chassis*

1. Access the inside of the system by removing the screws from the back lip of the top cover of the chassis, then pull the cover off.
2. The X7QC3 requires a chassis big enough to support a 16" x 14.3" serverboard, such as Supermicro's SC828TQ-R1200 .
3. Make sure that the I/O ports on the serverboard align properly with their respective holes in the I/O shield at the back of the chassis.
4. Carefully mount the serverboard to the serverboard tray by aligning the board holes with the raised metal standoffs that are visible in the chassis.
5. Insert screws into all the mounting holes on your serverboard that line up with the standoffs and tighten until snug (if you screw them in too tight, you might strip the threads). Metal screws provide an electrical contact to the serverboard ground to provide a continuous ground for the system.
6. Finish by replacing the top cover of the chassis.

## 5-3 Connecting Cables

Now that the serverboard is installed, the next step is to connect the cables to the board. These include the data (ribbon) cables for the peripherals and control panel and the power cables.

### Connecting Data Cables

The ribbon cables used to transfer data from the peripheral devices have been carefully routed to prevent them from blocking the flow of cooling air that moves through the system from front to back. If you need to disconnect any of these cables, you should take care to keep them routed as they were originally after reconnecting them (make sure the red wires connect to the pin 1 locations). The following data cables (with their locations noted) should be connected. (See the layout on page 5-9 for connector locations.)

- SAS drive data cables (JSM1, JSM2)
- Control Panel cable (JF1)
- DVD-ROM drive cable (J3)
- USB cable (USB5/6)
- COM port cable (COM2)

**Important!** Make sure the cables do not come into contact with the fans.

### Connecting Power Cables

The X7QC3 has a 24-pin primary power supply connector (JPW1) for connection to the ATX power supply. In addition, there is an 8-pin secondary power connector (JPW2) that also must be connected to your power supply (via a 4-pin connector). See Section 5-9 for power connector pin definitions.

### Connecting the Control Panel

JF1 contains header pins for various front control panel connectors. See Figure 5-1 for the pin locations of the various front control panel buttons and LED indicators.

All JF1 wires have been bundled into a single ribbon cable to simplify this connection. Make sure the red wire plugs into pin 1 as marked on the board. The other end connects to the Control Panel PCB board, located just behind the system status LEDs on the chassis. See Chapter 5 for details and pin descriptions.

**Figure 5-1. Control Panel Header Pins**

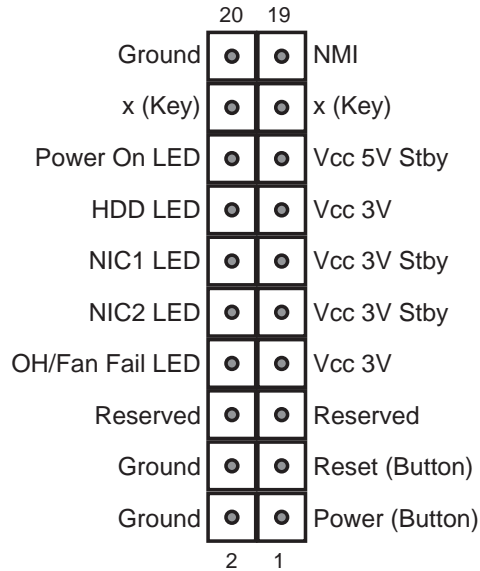

## 5-4 I/O Ports

The I/O ports are color coded in conformance with the PC 99 specification. See Figure 5-2 below for the colors and locations of the various I/O ports.

**Figure 5-2. I/O Ports**

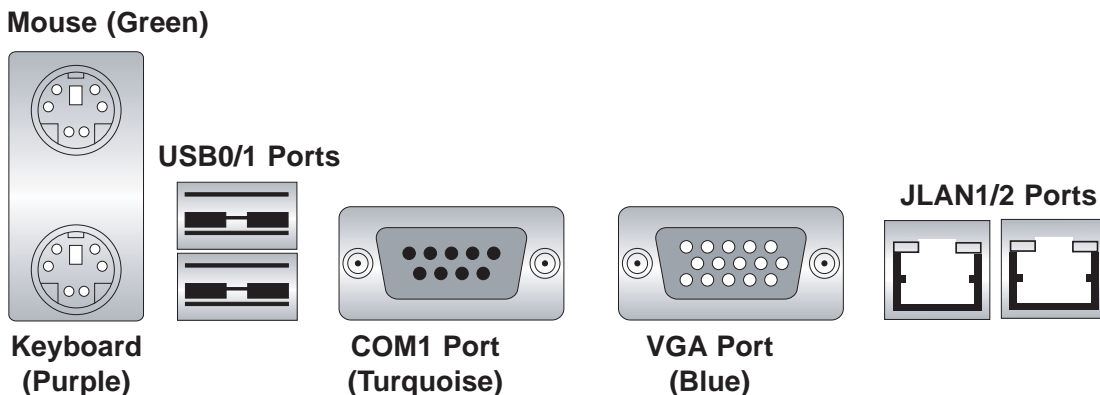

## 5-5 Installing the Processor and Heatsink



Avoid placing direct pressure to the top of the processor package. Always remove the power cord first before adding, removing or changing any hardware components.

**Notes:** Always connect the power cord last and remove it before adding, removing or changing any components. Make sure to install the processor into the CPU socket before you install the CPU heat sink.

Intel's boxed Xeon CPU package contains the CPU fan and heatsink assembly. If you buy the CPUs separately, use only Intel-certified heat sinks and fans.

Make sure to install the heat sink backplate and the serverboard into the chassis before you install the CPU heat sink and fan (see below).

Inspect the Xeon 7300/7200 INT-mPGA CPU socket and make sure that the CPU plastic cap is in place and none of the socket pins are bent. Otherwise, contact the retailer immediately.

All graphics shown in this manual are for reference only. The components that came with your serverboard may or may not look exactly the same as the pictures shown in this manual.

### ***Installation Procedure***

For proper system setup, please follow the procedure below:

1. Install the heatsink backplate into the chassis if needed
2. Install the serverboard into the chassis.
3. Install the CPU(s).
4. Install the heat sink or/and cooling fans (if any).
5. Connect fan and power cables.

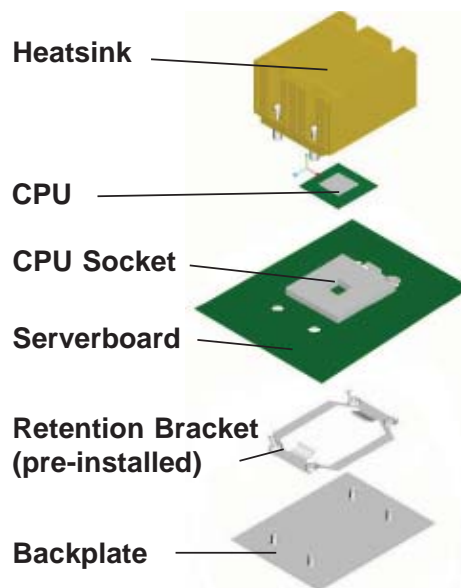

**CPU Installation**

1. Lift the lever on the CPU socket completely as shown in the picture on the right; otherwise, you will damage the CPU socket when power is applied. **Note:** if multiple CPUs are installed, be sure to install CPU1 first.
  
2. Insert the CPU in the socket, making sure that pin 1 of the CPU aligns with pin 1 of the socket (both corners are marked with a triangle). **Note:** When using only one CPU, install it into CPU socket #1. Please note that sockets #2, #3 and #4 will be automatically disabled if only one CPU is used.
  
3. Press the lever down until you hear a \*click\*, indicating that the CPU is securely installed in the CPU socket.

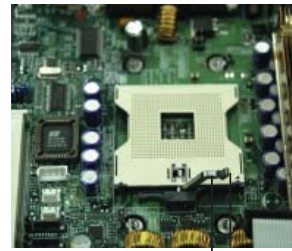

Socket lever



Pin1



Socket lever in the locked position



Warning! Make sure you lift the lever completely when installing the CPU; otherwise, damage to the socket or CPU may occur.

**Figure 5-3. PGA604 Socket: Empty and with Processor Installed**

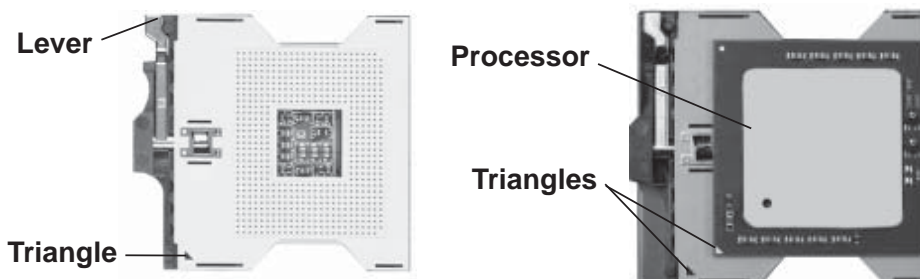

## Installation and Removal of the Heat Sink

### CEK Heat Sink Installation

1. Do not apply any thermal grease to the heat sink or the CPU die; the required amount has already been applied.
2. Place the heatsink on top of the CPU so that the four mounting holes are aligned with those on the retention mechanism.
3. Screw in two diagonal screws (i.e. the #1 and the #2 screws) until just snug (do not over-tighten the screws, which may damage the CPU.)
4. Finish the installation by fully tightening all four screws.

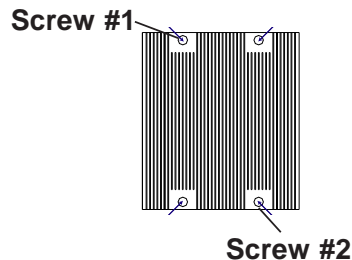
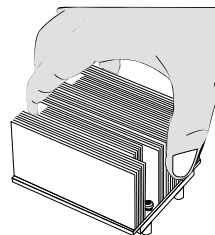

### Uninstalling the Heat Sink



**Warning:** We do not recommend removing the CPU or the heat sink. However, if you do need to uninstall the heat sink, please follow these instructions to avoid damaging the CPU or the CPU socket.

1. Unscrew and remove the heat sink screws in the sequence shown in the picture on the right.
2. Hold the heat sink as shown in the picture on the right and gently wriggle to loosen it from the CPU. (Do not use excessive force when doing this!)
3. Once the heat sink is loosened, remove it from the CPU socket.
4. Clean the surface of the CPU and the heat sink to get rid of the old thermal grease. Reapply the proper amount of thermal grease before you re-install the heat sink.

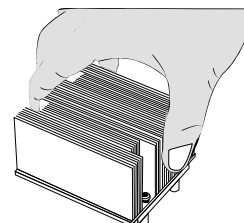
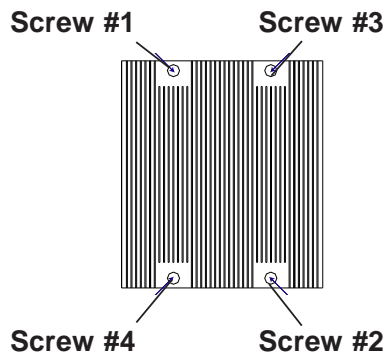

## 5-6 Installing Memory



CAUTION! Exercise extreme care when installing or removing DIMM modules to prevent any possible damage.

## 5-6 Installing Memory

### Memory Support

The X7QC3 supports up to 192 GB fully buffered (FBD) ECC DDR2 667/533 in 24 DIMM slots (four channels, two branches). Single channel memory, two-way interleaved memory and four-way interleaved memory schemes are all supported. Using four-way interleaved memory will result in the best performance. Please use memory modules of the same type, speed, and timing. **Note:** See the following table for memory installation.

#### Installing Memory Modules

1. Insert the desired number of FBD DDR2 modules into the memory slots, starting with DIMM #1A. To enhance memory performance, install pairs of memory modules of the same type and of the same, beginning with DIMM #1A and DIMM #2A, then DIMM #1B and DIMM #2B (see Memory Support above).
2. Insert each DIMM module vertically into its slot. Pay attention to the notch along the bottom of the module to avoid installing incorrectly (see Figure 5-4).
3. Gently press down on the DIMM module until it snaps into place in the slot. Repeat for all modules.

Memory Configuration Table																																		
	Branch 0												Branch 1																					
	Channel 0 (Bank 0)						Channel 1 (Bank 1)						Channel 2 (Bank 2)					Channel 3 (Bank 3)																
2 DIMMs	1A	---	---	---	---	---	1B	---	---	---	---	---	---	---	---	---	---	---	---	---	---	---	---	---	---	---	---	---	---	---	---	---	---	---
4 DIMMs	1A	---	---	---	---	---	1B	---	---	---	---	---	1C	---	---	---	---	---	---	---	---	---	---	1D	---	---	---	---	---	---	---	---	---	---
8 DIMMs	1A	2A	---	---	---	---	1B	2B	---	---	---	---	1C	2C	---	---	---	---	---	---	---	---	---	1D	2D	---	---	---	---	---	---	---	---	---
12 DIMMs	1A	2A	3A	---	---	---	1B	2B	3B	---	---	---	1C	2C	3C	---	---	---	---	---	---	---	---	1D	2D	3D	---	---	---	---	---	---	---	---
16 DIMMs	1A	2A	3A	4A	---	---	1B	2B	3B	4B	---	---	1C	2C	3C	4C	---	---	---	---	---	---	---	1D	2D	3D	4D	---	---	---	---	---	---	---
18 DIMMs	1A	2A	3A	4A	5A	---	1B	2B	3B	4B	5B	---	1C	2C	3C	4C	5C	---	---	---	---	---	---	1D	2D	3D	4D	5D	---	---	---	---	---	---
24 DIMMs	1A	2A	3A	4A	5A	6A	1B	2B	3B	4B	5B	6B	1C	2C	3C	4C	5C	6C	---	---	---	---	1D	2D	3D	4D	5D	6D	---	---	---	---	---	

\*Notes: i. "----" = DIMM slot not populated. ii. Both FBD DDR 533MHz and 668MHz are supported; however, please insert memory modules of the same type and speed, starting with Slot 1A. iii. Installing pairs of memory modules of the same type and speed will result in Interleaved memory. Single-way, Two-way Interleaved and four-way Interleaved memory schemes are supported. For best performance, please install pairs of memory modules in both Branch 0 and Branch 1, which will result in four-way interleaved memory scheme. iv. For memory to work properly, please follow the restrictions listed in the table.

Figure 5-4. DIMM Installation

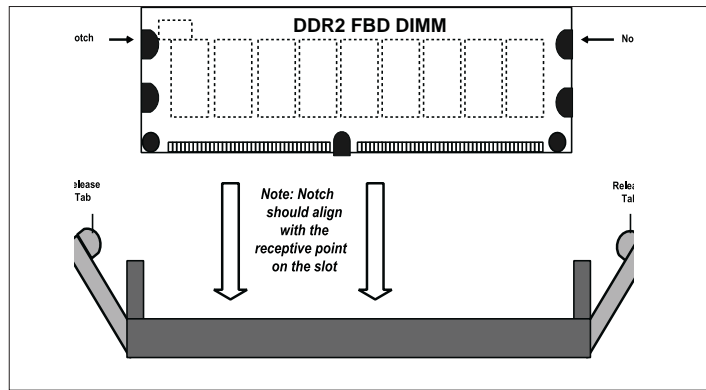

Top View of DDR2 Slot

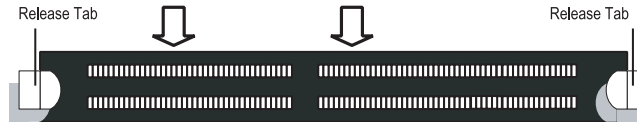

**To Install:** Insert module vertically and press down until it snaps into place. Pay attention to the bottom notches.

**To Remove:** Use your thumbs to gently push each release tab outward to free the DIMM from the slot.

## 5-7 Adding PCI Add-On Cards

The 8025C-3R can accommodate low-profile (only) add-on cards installed into all the PCI slots included on the X7QC3.

### *Installing an Add-on Card*

1. Begin by removing the PCI slot shield for the slot you wish to populate.
2. Fully seat the card into the riser card slot, pushing down with your thumbs evenly on both sides of the card.
3. Finish by using a screw to secure the top of the card shield to the chassis. The PCI slot shields protect the serverboard and its components from EMI and aid in proper ventilation, so make sure there is always a shield covering each unused slot.

## 5-8 Serverboard Details

Figure 5-5. X7QC3 Layout  
(not drawn to scale)

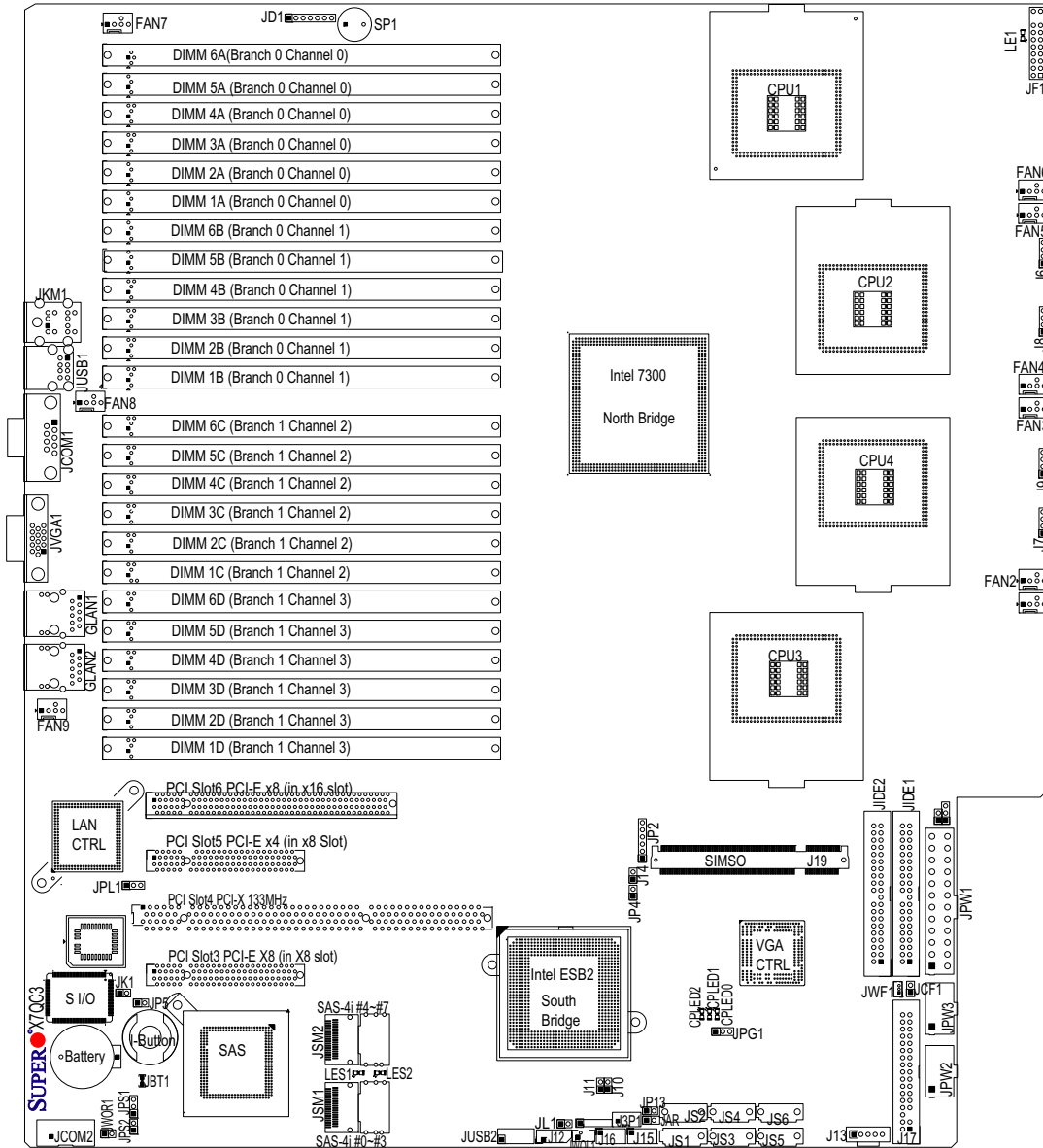

## X7QC3 Quick Reference

<b>Jumper</b>	<b>Description</b>	<b>Default Setting</b>
J10/J11	SMB to PCI Slots #3/#4/#5/#6	Both Open (Disabled)
JBT1	CMOS Clear	(See Section 5-10)
JCF1	Compact Flash Card Master/Slave	Pins 1-2 (Master)
JP5	CPU PWR Select	Open (130W for 2U)
JP13	3rd Power Supply Fail Detect	Open (Disabled)
JPG1	VGA Enable/Disable	Pins 1-2 (Enabled)
JPL1	GLAN1/2 Enable/Disable	Pins 1-2 (Enabled)
JPS1	SAS/SATA (JSM1/JSM2) En/Disable	Pins 1-2 (Enabled)
JPS2	SAS/SATA RAID Mode	Closed(Integrated RAID)
JWD	Watch Dog	Pins 1-2 (Reset)

<b>Connector</b>	<b>Description</b>
FAN 1-9	Chassis/CPU Fan Headers
GLAN1/2	Gigabit Ethernet (RJ45) Ports
J12	IPMB Header (of the IPMI module)
J13	PWR SMBus I <sup>2</sup> C Connector
J15/J16	Serial General Purpose Input/Output Headers
J17	Floppy Disk Drive Connector
J19	SIMSO Slot
J3P1	PWR Supply Fail LED
JAR	Alarm Rest Header
JCOM1/JCOM2	COM1 Serial Port/Header
JD1	Onboard Speaker/Power LED
JF1	Front Panel Connector
JIDE1/JIDE2	IDE Drive/Compact Flash Card Connector
JL1	Chassis Intrusion Header
JOH1	Overheat Warning Header
JPW1	24-pin ATX Power Connector
JPW2/JPW3	+12V 8-Pin Processor Power Connectors
JS1~6	SATA Ports 1~6
JSM1/JSM2	SAS/SATA Ports #0-3/SAS/SATA Ports #4-7
JUSB1/2/3	Universal Serial Bus (USB) Ports/Headers
JWF1	Compact Flash Card Power Connector
JWOL1	Wake-On-LAN Header
JWOR1	Wake-On-Ring Header

## 5-9 Connector Definitions

### Main ATX Power Supply Connector

The primary power supply connector (JPW1) meets the SSI (Superset ATX) 24-pin specification. Refer to the table on the right for the pin definitions of the ATX 24-pin power connector. You must also connect the 8-pin (JPW2/JPW3) processor power connectors to your power supply (see below).

ATX Power 24-pin Connector Pin Definitions (JPW1)			
Pin#	Definition	Pin #	Definition
13	+3.3V	1	+3.3V
14	-12V	2	+3.3V
15	COM	3	COM
16	PS_ON	4	+5V
17	COM	5	COM
18	COM	6	+5V
19	COM	7	COM
20	Res (NC)	8	PWR_OK
21	+5V	9	5VSB
22	+5V	10	+12V
23	+5V	11	+12V
24	COM	12	+3.3V

### Processor Power Connector

JPW2 and JPW3 must also be connected to the power supply to provide power for the processors. See the table on the right for pin definitions.

+12V 8-pin Power Pin Definitions (JPW2/JPW3)	
Pins	Definition
1 - 4	Ground
5 - 8	+12V

#### Required Connection

### PW\_ON Connector

The PW\_ON connector is on pins 1 and 2 of JF1. This header should be connected to the chassis power button. See the table on the right for pin definitions.

Power Button Pin Definitions (JF1)	
Pin#	Definition
1	PW_ON
2	Ground

### Reset Connector

The reset connector is located on pins 3 and 4 of JF1 and attaches to the reset switch on the computer chassis. See the table on the right for pin definitions.

Reset Button Pin Definitions (JF1)	
Pin#	Definition
3	Reset
4	Ground

**Overheat/Fan Fail LED (OH)**

Connect an LED to the OH connection on pins 7 and 8 of JF1 to provide advanced warning of chassis overheating. Refer to the table on the right for pin definitions.

OH/Fan Fail LED Pin Definitions (JF1)		OH/Fan Fail Indicator Status	
Pin#	Definition	State	Definition
7	Vcc	Off	Normal
8	Ground	On	Overheat
		Flash- ing	Fan Fail

**NIC2 (JLAN2) LED**

The LED connections for JLAN2 are on pins 9 and 10 of JF1. Attach an LED cable to display network activity. See the table on the right for pin definitions.

NIC2 LED Pin Definitions (JF1)	
Pin#	Definition
9	Vcc
10	Ground

**NIC1 (JLAN1) LED**

The LED connections for JLAN1 are on pins 11 and 12 of JF1. Attach an LED cable to display network activity. See the table on the right for pin definitions.

NIC1 LED Pin Definitions (JF1)	
Pin#	Definition
11	Vcc
12	Ground

**HDD LED**

The HDD LED connection is located on pins 13 and 14 of JF1. This LED is used to display all IDE and SAS activity. See the table on the right for pin definitions.

HDD LED Pin Definitions (JF1)	
Pin#	Definition
13	Vcc
14	HD Active

### Power On LED

The Power On LED connector is located on pins 15 and 16 of JF1 (use JLED for a 3-pin connector). This connection is used to provide LED indication of power being supplied to the system. See the table on the right for pin definitions.

Power LED Pin Definitions (JF1)	
Pin#	Definition
15	5V Stby
16	Control

### NMI Button

The non-maskable interrupt button header is located on pins 19 and 20 of JF1. Refer to the table on the right for pin definitions.

NMI Button Pin Definitions (JF1)	
Pin#	Definition
19	Control
20	Ground

### Fan Headers

There are nine fan headers on the serverboard, all of which are 4-pin fans. However, pins 1-3 of the fan headers are backward compatible with the traditional 3-pin fans. See the table on the right for pin definitions. The onboard fan speeds are controlled by Thermal Management (via Hardware Monitoring) under the Advanced Section in the BIOS. The default is disabled. When using Thermal Management setting, please use all 3-pin fans or all 4-pin fans.

Fan Header Pin Definitions (FAN1-9)	
Pin#	Definition
1	Ground (Black)
2	+12V (Red)
3	Tachometer
4	PWM Control

### ATX PS/2 Keyboard and PS/2 Mouse Ports

The ATX PS/2 keyboard and the PS/2 mouse are located on JKM1. The mouse port is above the keyboard port. See the table on the right for pin definitions.

PS/2 Keyboard and Mouse Port Pin Definitions (JKM1)	
Pin#	Definition
1	Data
2	NC
3	Ground
4	VCC
5	Clock
6	NC

### Chassis Intrusion

The Chassis Intrusion header is designated JL1. Attach an appropriate cable from the chassis to inform you of a chassis intrusion when the chassis is opened

Chassis Intrusion Pin Definitions (JL1)	
Pin#	Definition
1	Intrusion Input
2	Ground

### Wake-On-LAN

The Wake-On-LAN header is designated JWOL1 on the serverboard. See the table on the right for pin definitions. You must also have a LAN card with a Wake-On-LAN connector and cable to use this feature.

Wake-On-LAN Pin Definitions (JWOL1)	
Pin#	Definition
1	+5V Standby
2	Ground
3	Wake-up

### Wake-On-Ring

The Wake-On-Ring header is designated JWOR1. This function allows your computer to receive and be "awakened" by an incoming call when in the suspend state. See the table on the right for pin definitions. You must also have a WOR card and cable to use this feature.

Wake-On-Ring Pin Definitions (JWOR1)	
Pin#	Definition
1	Ground (Black)
2	Wake-up

### Power Supply Fail LED

Connect a cable from your power supply to J3P1 to provide warning of power supply failure. This warning signal is passed through the PWR\_LED pin to indicate of a power failure on the chassis. See the table on the right for pin definitions.

PWR Supply Fail LED Pin Definitions (J3P1)	
Pin#	Definition
1	PWR 1: Fail
2	PWR 2: Fail
3	PWR 3: Fail
4	Signal: Alarm Reset

**Note:** This feature is only available when using Supermicro redundant power supplies.

### GLAN1/2 (Ethernet Ports)

Two Ethernet ports (designated GLAN1 and GLAN2) are located beside the VGA port on the I/O backplane. These ports accept RJ45 type cables.



### Serial Ports

Two serial ports are included on the serverboard. COM1 is a backpanel port and COM2 is a header located near the onboard battery. See the table on the right for pin definitions.

Serial Port Pin Definitions (COM1/COM2)			
Pin #	Definition	Pin #	Definition
1	DCD	6	DSR
2	RXD	7	RTS
3	TXD	8	CTS
4	DTR	9	RI
5	Ground	10	NC

### Power LED/Speaker

On JD1 header, pins 1-3 are for a power LED and pins 4-7 are for the speaker. Close pins 4-7 with a jumper to use an external speaker. If you wish to use the onboard speaker, please close pins 6-7. See the table on the right for speaker pin definitions.

Power LED/Speaker Connector (JD1)	
Pin Setting	Definition
Pins 6-7	Internal Speaker
Pins 4-7	External Speaker

### Universal Serial Bus (USB)

There are two Universal Serial Bus ports located on the I/O panel and three additional USB headers located on the serverboard. The headers can be used to provide front side USB access (cables not included). See the table on the right for pin definitions.

Universal Serial Bus Pin Definitions (USB)			
USB0/1		USB2/3/4	
Pin #	Definition	Pin #	Definition
1	+5V	1	+5V
2	PO-	2	PO-
3	PO+	3	PO+
4	Ground	4	Ground
5	N/A	5	Key

### SGPIO Header

The SGPIO (Serial General Purpose Input/Output) headers are located at J15/J16. These headers are used to communicate with a system-monitoring chip on the backplane. See the table on the right for pin definitions.

SGPIO Header Pin Definitions (J15/J16)			
Pin#	Definition	Pin	Definition
1	*NC	2	*NC
3	Ground	4	DATA Out
5	Load	6	Ground
7	Clock	8	*NC

NC = No Connection

### Alarm Reset

If three power supplies are installed, the system can notify you when any of the three power modules fail. Connect JAR to a micro-switch to enable you to turn off the alarm that is activated when a power module fails. See the table on the right for pin definitions.

Alarm Reset Header Pin Definitions (JAR)	
Pin Setting	Definition
Pin 1	Ground
Pin 2	+5V

### Power SMB (I<sup>2</sup>C) Connector

Power SMB (I<sup>2</sup>C) connector, located at J13, monitors the status of the power supply, fan and system temperature. See the table on the right for pin definitions.

PWR SMB Header Pin Definitions (J13)	
Pin#	Definition
1	Clock
2	Data
3	PWR Fail (Input from PS to MB)
4	Ground
5	+3.3V

### Compact Flash Card PWR Connector

A Compact Flash Card Power Connector is located at JWF1. For the Compact Flash Card to work properly, you will need to enable with JCF1 and connect a Compact Flash Card power cable to JWF1 first.

Compact Flash Card PWR Connector (JWF1)	
Jumper	Definition
On	Compact Flash Power On
Off	Compact Flash Power Off

### Overheat LED/Fan Fail (JOH1)

The JOH1 header is used to connect an LED to provide warning of chassis overheating. This LED will blink to indicate a fan failure. Refer to the table on right for pin definitions.

OH/Fan Fail LED States		Overheat LED Pin Definitions (JOH1)	
State	Message	Pin#	Definition
Solid	Overheat	1	5vDC
Blinking	Fan Fail	2	OH Active

### Keylock

The keyboard lock connection is designated JK1. Utilizing this header allows you to inhibit any actions made on the keyboard, effectively "locking" it.

Keylock Pin Definitions (JK1)	
Pin#	Definition
1	Ground
2	Keylock R-N

### IPMB Header

The IPMB Header of IPMI is designated J12. See the table on right for pin definitions.

IPMB Header Pin Definitions (J12)	
Pin#	Definition
1	SDATA
2	GND
3	SCLK
4	NC

## 5-10 Jumper Settings

### Explanation of Jumpers

To modify the operation of the serverboard, jumpers can be used to choose between optional settings. Jumpers create shorts between two pins to change the function of the connector. Pin 1 is identified with a square solder pad on the printed circuit board. See the serverboard layout pages for jumper locations.

**Note:** On a two-pin jumper, "Closed" means the jumper is on both pins and "Open" means the jumper is either on only one pin or completely removed.

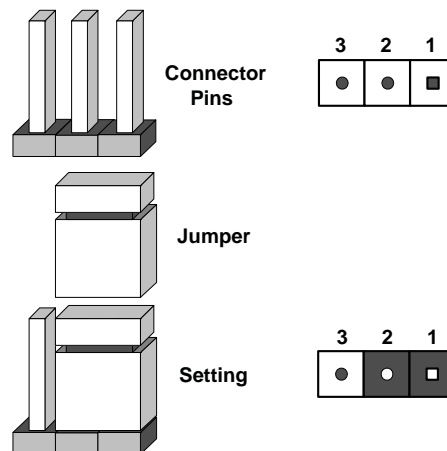

## CMOS Clear

JBT1 is used to clear CMOS (which will also clear any passwords). Instead of pins, this jumper consists of contact pads to prevent accidentally clearing the contents of CMOS.

### To clear CMOS,

1. First power down the system and unplug the power cord(s).
2. With the power disconnected, short the CMOS pads with a metal object such as a small screwdriver.
3. Remove the screwdriver (or shorting device).
4. Reconnect the power cord(s) and power on the system.

**Note:** Do not use the PW ON connector to clear CMOS.

## VGA Enable/Disable

JPG1 allows you to enable or disable the VGA port. The default position is on pins 1 and 2 to enable VGA. See the table on the right for jumper settings.

VGA Enable/Disable Jumper Settings (JPG1)	
Jumper Setting	Definition
Pins 1-2	Enabled
Pins 2-3	Disabled

## GLAN1/2 Enable/Disable

Change the setting of jumper JPL1 to enable or disable the GLAN1/GLAN2 Ethernet port on the serverboard. See the table on the right for jumper settings. The default setting is enabled.

GLAN1/2 Enable/Disable Jumper Settings (JPL1)	
Jumper Setting	Definition
Pins 1-2	Enabled
Pins 2-3	Disabled

## 3rd Power supply Fail Detect

The system can notify you in the event of a power supply failure. This feature is available when three power supply units are installed in the chassis with one acting as a backup. If you only have one or two power supply units installed, you should disable this detection feature (the default setting) with JP13 to prevent false alarms.

3rd Power Supply Fail Detect Jumper Settings (JP13)	
Jumper Setting	Definition
Closed	Enabled
Open	Disabled

### Watch Dog Enable/Disable

JWD controls the Watch Dog function. Watch Dog is a system monitor that can reboot the system when a software application hangs. Jumping pins 1-2 will cause WD to reset the system if an application hangs. Jumping pins 2-3 will generate a non-maskable interrupt signal for the application that hangs. See the table on the right for jumper settings. Watch Dog must also be enabled in BIOS.

Watch Dog Jumper Settings (JWD)	
Jumper Setting	Definition
Pins 1-2	Reset
Pins 2-3	NMI
Open	Disabled

**Note:** When enabled, the user needs to write their own application software in order to disable the Watch Dog Timer.

### Compact Flash Master/Slave Select

A Compact Flash Master (Primary)/ Slave (Secondary) Select Jumper is located at JCF1. Close this jumper to enable Compact Flash Card. For the Compact Flash Card or the Compact Flash Jumper (JCF1) to work properly, you will need to connect the Compact Flash Card power cable to JWF1 first. Refer to the board layout below for the location.

Compact Flash Card Master/ Slave Select (JCF1)	
Jumper	Definition
Open	Slave (Secondary)
Closed	Master (Primary)

### I<sup>2</sup>C Bus to PCI-X/PCI-Exp. Slots

Jumpers J10 and J11 allow you to connect the System Management Bus (I<sup>2</sup>C) to PCI-X/PCI-E slots 3/4/5/6. The default setting is Open (Disabled.) Both jumpers must be set to the same setting See the table on the right for jumper settings.

I <sup>2</sup> C to PCI-X/PCI-E Slots Jumper Settings (J10/J11)		
Jumper Setting	Definition	
J10: Closed	J11: Closed	Enabled
J10: Open	J11: Open	Disabled

### SAS/SATA Enable/Disable

JPS1 allows you to enable or disable the JSM1 and JSM2 ports, which may be used for either SAS or SATA HDDs. See the table on the right for jumper settings.

SAS/SATA Enable/Disable Jumper Settings (JPS1)	
Jumper Setting	Definition
Pins 1-2	SAS/SATA Enabled
Pins 2-3	SAS/SATA Disabled

### RAID Mode

JPS2 allows you to switch between the two RAID modes available: MegaRAID and Integrated RAID (the latter requires you to refresh the firmware). See the table on the right for jumper settings.

RAID Mode Jumper Settings (JPS2)	
Jumper Setting	Definition
Closed	MegaRAID
Open	Integrated RAID

### CPU Power Select

JP5 allows you to select the CPU power settings. The default position is "Open" to support 130 W for 2U systems. See the table on the right for jumper settings.

CPU PWR Select Jumper Settings (JP5)	
Jumper Setting	Definition
Open	130W for 2U Platform
Closed	80W for 1U Platform

## 5-11 Onboard Indicators

### GLAN1/2 LEDs

The Ethernet ports (located beside the VGA port) have two LEDs. On each port, one LED indicates activity while the other LED may be green, amber or off to indicate the speed of the connection. See the table on the right for the functions associated with the connection speed LED.

GLAN1/2 LED (Connection Speed Indicator)	
LED Color	Definition
Off	10 MHz
Green	100 MHz
Amber	1 GHz

### Onboard Power LED (LE1)

An Onboard Power LED is located at LE1. This LED Indicator is on when the system is on. Be sure to unplug the power cable before removing or adding any components. See the table on the right for more details.

Onboard PWR LED Indicator (LE1)	
LED Color	Definition
Off	System Off (PWR cable not connected)
Green	System On
Green: Flashing Quickly	ACPI S1 State
Green: Flashing Slowly	ACPI S3 (STR) State

### SAS Activity LED

LES1 is used to indicate the status of SAS activity.

SAS Activity LED Indicator (LES1)	
LED Color	Definition
On	SAS Port Active
Off	SAS Port Inactive

### SAS Heartbeat LED

A SAS Heartbeat LED is located at LES2. When on, it indicates that the LSI1068E SAS controller is operating.

## 5-12 Floppy, IDE, and SAS Ports

Use the following information to connect the IDE hard disk drive cables.

- A red mark on a wire typically designates the location of pin 1.
- The 80-wire ATA100/66 IDE hard disk drive cable that came with your system has two connectors to support two drives. This special cable should be used to take advantage of the speed this new technology offers. The blue connector connects to the onboard IDE connector interface and the other connector(s) to your hard drive(s). Consult the documentation that came with your disk drive for details on actual jumper locations and settings for the hard disk drive.

### Floppy Connector

The floppy connector is located at J17. See the table below for pin definitions.

Floppy Drive Connector Pin Definitions (J17)			
Pin#	Definition	Pin #	Definition
1	Ground	2	FDHDIN
3	Ground	4	Reserved
5	Key	6	FDEDIN
7	Ground	8	Index
9	Ground	10	Motor Enable
11	Ground	12	Drive Select B
13	Ground	14	Drive Select B
15	Ground	16	Motor Enable
17	Ground	18	DIR
19	Ground	20	STEP
21	Ground	22	Write Data
23	Ground	24	Write Gate
25	Ground	26	Track 00
27	Ground	28	Write Protect
29	Ground	30	Read Data
31	Ground	32	Side 1 Select
33	Ground	34	Diskette

### IDE Connectors

There are two IDE Connectors (JIDE1: Blue, JIDE2: White) on the serverboard. JIDE1 is designated as the Primary IDE drive. JIDE2 is designated as the Secondary IDE drive and is reserved for Compact Flash Card use only. (See the note below.) See the table on the right for pin definitions.

**Note:** JIDE2 (the white slot) is reserved for Compact Flash Card only. Do not use it for other devices. If JIDE2 is populated with a Compact Flash Card, JIDE1 (the blue slot) will be available for one device only. For the Compact Flash Card to work properly, you will need to connect a power cable to JWF1 first.

IDE Drive Connectors Pin Definitions (JIDE1/JIDE2)			
Pin#	Definition	Pin #	Definition
1	Reset IDE	2	Ground
3	Host Data 7	4	Host Data 8
5	Host Data 6	6	Host Data 9
7	Host Data 5	8	Host Data 10
9	Host Data 4	10	Host Data 11
11	Host Data 3	12	Host Data 12
13	Host Data 2	14	Host Data 13
15	Host Data 1	16	Host Data 14
17	Host Data 0	18	Host Data 15
19	Ground	20	Key
21	DRQ3	22	Ground
23	I/O Write	24	Ground
25	I/O Read	26	Ground
27	IOCHRDY	28	BALE
29	DACK3	30	Ground
31	IRQ14	32	IOCS16
33	Addr1	34	Ground
35	Addr0	36	Addr2
37	Chip Select 0	38	Chip Select 1
39	Activity	40	Ground

### SATA Ports

There are no jumpers to configure the onboard SATA connectors. See the table on the right for pin definitions.

SATA Ports Pin Definitions (JS1-JS6)	
Pin #	Definition
1	Ground
2	TXP
3	TXN
4	Ground
5	RXN
6	RXP
7	Ground

## Chapter 6

### Advanced Chassis Setup

This chapter covers the steps required to install components and perform maintenance on the SC828TQ-R1200 chassis. For component installation, follow the steps in the order given to eliminate the most common problems encountered. If some steps are unnecessary, skip ahead to the step that follows.

**Tools Required:** The only tool you will need to install components and perform maintenance is a Philips screwdriver.

#### 6-1 Static-Sensitive Devices

Electrostatic discharge (ESD) can damage electronic components. To prevent damage to any printed circuit boards (PCBs), it is important to handle them very carefully. The following measures are generally sufficient to protect your equipment from ESD damage.

##### **Precautions**

- Use a grounded wrist strap designed to prevent static discharge.
- Touch a grounded metal object before removing any board from its antistatic bag.
- Handle a board by its edges only; do not touch its components, peripheral chips, memory modules or gold contacts.
- When handling chips or modules, avoid touching their pins.
- Put the motherboard, add-on cards and peripherals back into their antistatic bags when not in use.
- For grounding purposes, make sure your computer chassis provides excellent conductivity between the power supply, the case, the mounting fasteners and the serverboard.

## Unpacking

The serverboard is shipped in antistatic packaging to avoid static damage. When unpacking the board, make sure the person handling it is static protected.

**Figure 6-1. Front and Rear Chassis Views**

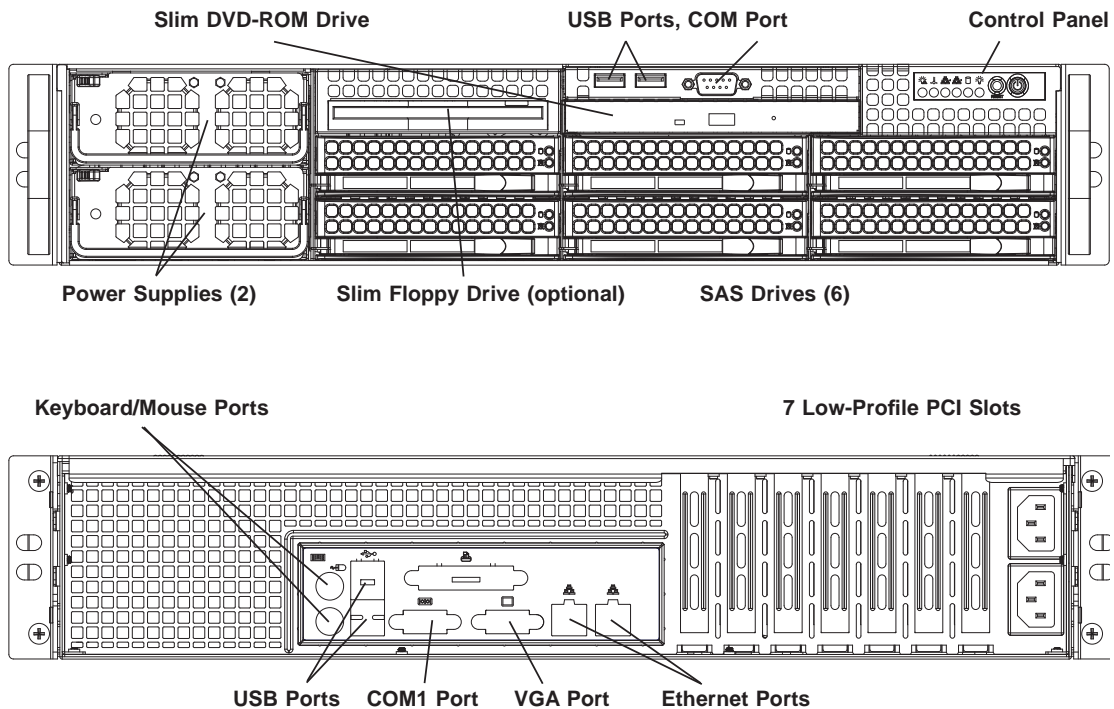

## 6-2 Control Panel

The control panel (located on the front of the chassis) must be connected to the JF1 connector on the serverboard to provide you with system status indications. A ribbon cable has bundled these wires together to simplify the connection. Connect the cable from JF1 on the serverboard to JP4 on the Control Panel PCB (printed circuit board). Make sure the red wire plugs into pin 1 on both JF1 and JP4. Pull all excess cabling out of the airflow path. The LEDs inform you of system status. See Chapter 3 for details on the LEDs and the control panel buttons. Details on JF1 can be found in Chapter 5.

## 6-3 System Fans

Six heavy-duty redundant hot-swap fans provide the cooling for the SuperServer 8025C-3R. The fans are configured as a set of three with two fans placed back to back to maximize airflow. It is very important that the chassis top cover is properly installed in order for the cooling air to circulate properly through the chassis and cool the components. See Figure 6-2.

### System Fan Failure

Fan speed is controlled by system temperature via a BIOS setting. If a fan fails, the remaining fans will ramp up to full speed and the overheat/fan fail LED on the control panel will turn on. Replace any failed fan at your earliest convenience with the same type and model (the system can continue to run with a failed fan). Remove the top chassis cover while the system is still running to determine which of the fans has failed.

### Replacing System Fans

#### *Removing a fan*

1. Remove the chassis cover (see page 6-7 for procedure).
2. Press the tabs on the sides of the fan to unlock and remove the fan and its housing.
3. The fan's power connections will automatically detach. System power does not need to be shut down since the fans are hot-pluggable.

#### *Installing a new fan*

1. Replace the failed fan with an identical 8-cm, 12 volt fan (available from Supermicro, p/n FAN-0099L).
2. Position the new fan into the space vacated by the failed fan previously removed. A "click" can be heard when the fan is fully installed in place and the power connections are made.
3. If the system power is on, the hot-plug feature will cause the fan to start immediately upon being connected to its header on the serverboard.
4. Replace the chassis cover.

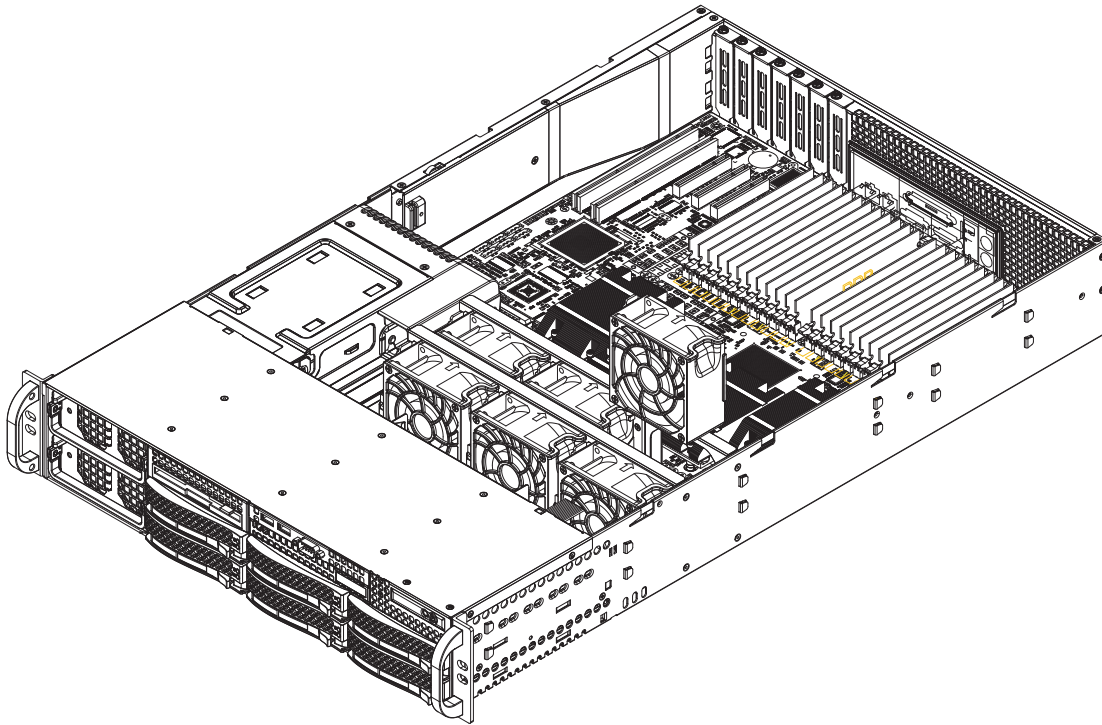
**Figure 6-2. Removing System Cooling Fans**

## 6-4 Drive Bay Installation/Removal

### Accessing the Drive Bays

**SAS Drives:** You do not need to access the inside of the chassis or remove power to replace or swap SAS drives. Proceed to the next step for instructions. **Note:** You must use standard 1" high, SAS drives in the SuperServer 8025C-3R.

**DVD-ROM:** For installing/removing the DVD-ROM drive, you will need to gain access to the inside of the server by removing the top cover of the chassis. Proceed to the "DVD-ROM Installation" section later in this chapter for instructions.

## SAS Drive Installation

The SAS drives are mounted in drive carriers to simplify their installation and removal from the chassis. These carriers also help promote proper airflow for the drives. For this reason, even empty carriers without SAS drives installed must remain in the chassis.

### *Mounting a SAS drive in a drive carrier*

1. Install a drive into the carrier with the printed circuit board side facing down so that the mounting holes align with those in the carrier.
2. Secure the drive to the carrier with six screws, as shown in Figure 6-3.

Figure 6-3. Mounting a SAS Drive in a Carrier

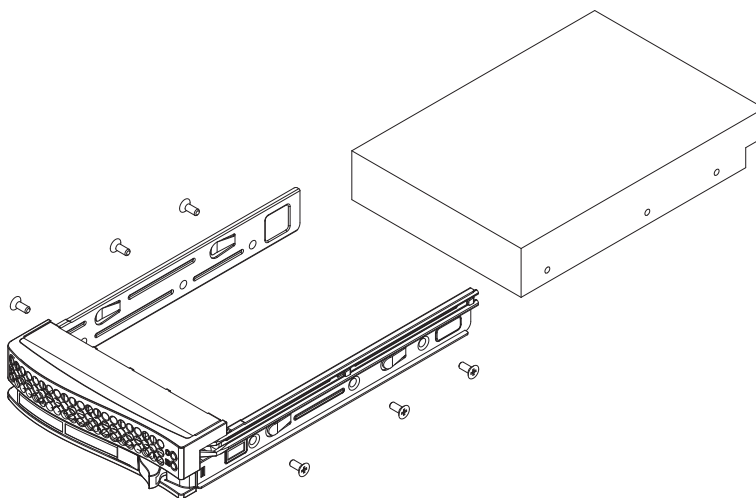

Use caution when working around the SAS backplane. Do not touch the backplane with any metal objects and make sure no ribbon cables touch the backplane or obstruct the holes, which aid in proper airflow.



**Important:** Regardless of how many SAS hard drives are installed, all drive carriers must remain in the drive bays to maintain proper airflow.

The SAS drive carriers are located in the front of the chassis, making them easily accessible for installation and removal. These drives are hot-swappable, meaning that they can be installed and removed while the system is running.

***Installing/removing SAS drives***

1. To remove a SAS drive, first push the release button located beside the drive's LEDs
2. Swing the handle fully out and use it to pull the SAS drive carrier straight out (see Figure 6-4).

**Note:** Your operating system must have RAID support to enable the hot-plug capability of the SAS drives.

**Figure 6-4. Removing a SAS Drive Carrier**

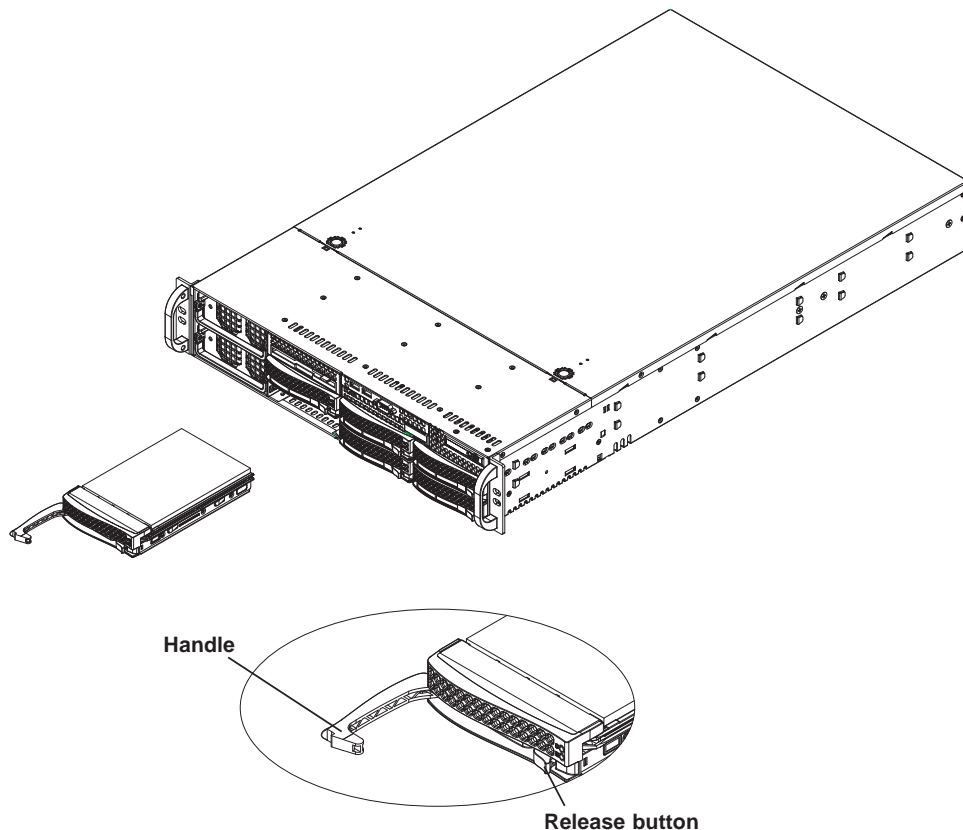

**Important:** All of the SAS drive carriers must remain in the drive bays to maintain proper cooling airflow.

## SAS Drive Backplane

The SAS drives plug into a backplane that provides power, drive ID and bus termination. A RAID controller can be used with the backplane to provide data security. The operating system you use must have RAID support to enable the hot-swap capability of the SAS drives. The backplane is already preconfigured, so there are no jumpers or switches present on it. DVD-ROM Drive Installation

The top cover of the chassis must be opened to gain full access to the DVD-ROM drive bay. The 8025C-3R accommodates only slim type DVD-ROM drives. Side mounting brackets are typically needed to mount a slim DVD-ROM drive in the 8025C-3R server. You must power down the system before installing or removing IDE components. See the Figures below for connector and component locations.

Figure 6-5. Backplane Connections

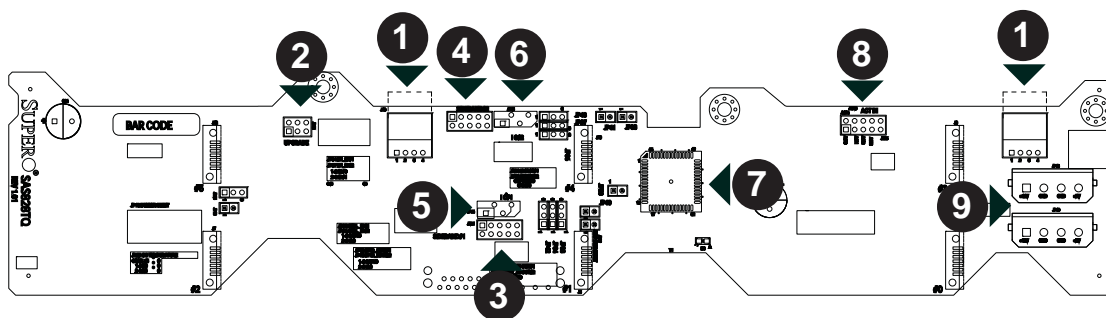

SAS Backplane Connections	
1. CD-ROM/Floppy Drive Power	9. 4-pin Power Connectors
2. Upgrade Connector	10. SAS Port #0
3. Sideband Connector #1	11. SAS Port #1
4. Sideband Connector #2	12. SAS Port #2
5. I2C Connector #1	13. SAS Port #3
6. I2C Connector #2	14. SAS Port #4
7. MG9072 Chip	15. SAS Port #5
8. ACT_IN	

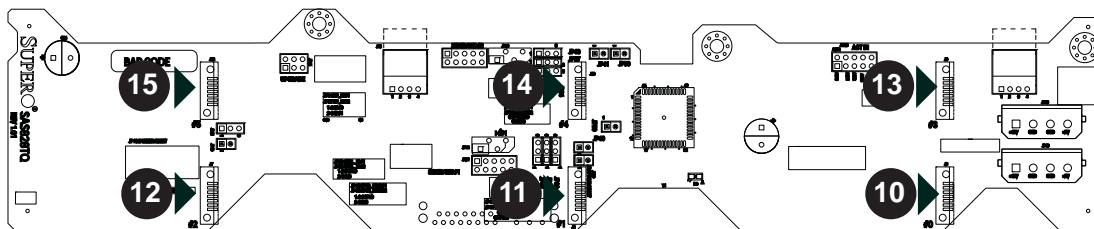

## 6-5 Power Supply

The SuperServer 8025C-3R has a 1200 watt redundant power supply consisting of two power modules. Each power supply module has an auto-switching capability, which enables it to automatically sense and operate at a 100V - 240V input voltage.

### Power Supply Failure

If either of the two power supply modules fail, the other module will take the full load and allow the system to continue operation without interruption. The PWR Fail LED will illuminate and remain on until the failed unit has been replaced. Replacement units can be ordered directly from Supermicro (see contact information in the Preface). The power supply units have a hot-swap capability, meaning you can replace the failed unit without powering down the system.

### Removing/Replacing the Power Supply

You do not need to shut down the system to replace a power supply unit. The backup power supply module will keep the system up and running while you replace the failed hot-swap unit. Replace with the same model (see part number in Appendix D), which can be ordered directly from Supermicro.

#### *Removing the power supply*

1. First unplug the power cord from the failed power supply module. The top/bottom power socket corresponds to the top/bottom power module.
2. Depress the locking tab on the power supply module.
3. Use the handle to pull the module straight out.

#### *Installing a new power supply*

1. Replace the failed hot-swap unit with another identical power supply unit.
2. Push the new power supply unit into the power bay until you hear a click.
3. Finish by plugging the AC power cord back into the socket.

**Figure 6-6. Removing a Power Supply Module**

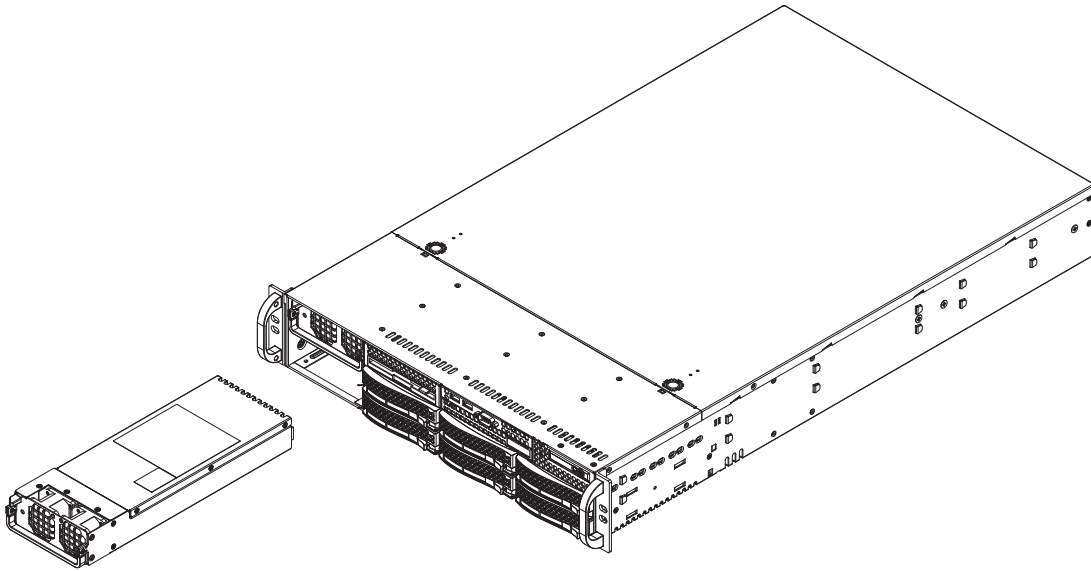

**Notes**

# Chapter 7

## BIOS

### 7-1 Introduction

This chapter describes the AMIBIOS Setup Utility for the X7QC3. The AMI ROM BIOS is stored in a Flash EEPROM and can be easily updated using a floppy disk-based program.

#### Starting BIOS Setup Utility

To enter the AMIBIOS Setup Utility screens, hit the <Delete> key while the system is booting up.

**Note:** In most cases, the <Delete> key is used to invoke the AMIBIOS setup screen. There are a few cases when other keys are used, such as <F1>, <F2>, etc.

The Main BIOS setup menu screen has two main frames. The left frame displays all the options that can be configured. “Grayed-out” options cannot be configured. Options in blue can be configured by the user. The right frame displays the key legend. Above the key legend is an area reserved for a text message. When an option is selected in the left frame, it is highlighted in white. Often a text message will accompany it. (**Note:** the AMI BIOS has default text messages built in. Supermicro retains the option to include, omit, or change any of these text messages.)

The AMIBIOS Setup Utility uses a key-based navigation system called hot keys. Most of the AMIBIOS setup utility hot keys can be used at any time during the setup navigation process. These keys include <F1>, <F10>, <Enter>, <ESC>, arrow keys, etc. Options printed in **Bold** are default settings.)

The configuration data that determines the system parameters may be changed by entering the AMI BIOS Setup utility (accessed by pressing <Del> during system boot.



**Warning!!** Do not shut down or reset the system while updating the BIOS to prevent possible boot failure.

## 7-2 Main Setup

When you first enter the AMI BIOS Setup Utility, you will enter the Main setup screen. You can always return to the Main setup screen by selecting the **Main** tab at the top of the screen. The Main BIOS Setup screen is shown below.

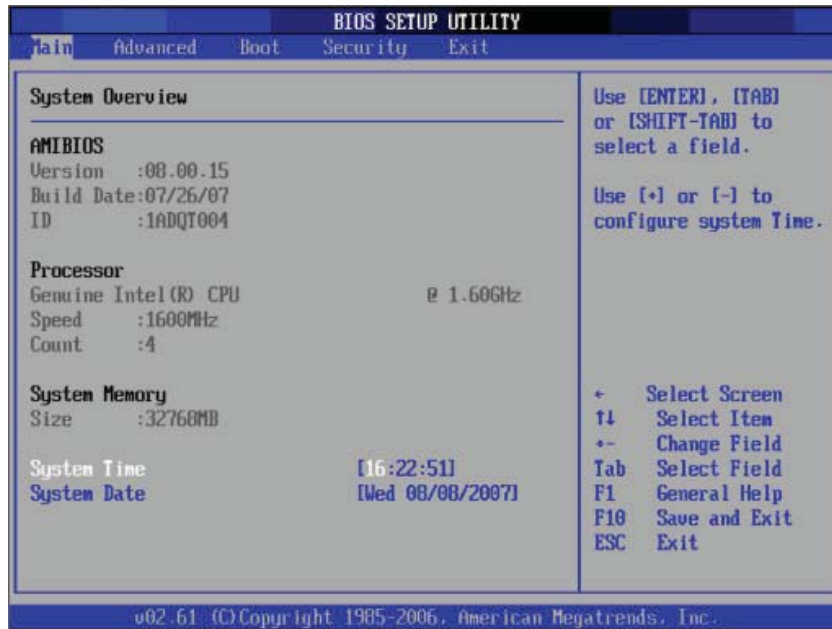

When you select the Main Setup, the following items will be automatically displayed:

### AMIBIOS

Version/Build Date/ID

### Processors

When you select this option, the AMI BIOS will automatically display the status of processors.

### System Memory

This option allows the AMI BIOS to display the status of memory modules installed in the system.

### System Time/System Date

Use this option to change the system time and date. Highlight *System Time* or *System Date* using the arrow keys. Enter new values through the keyboard. Press the <Tab> key or the arrow keys to move between fields. The date must be entered in DAY/MM/DD/YY format. The time is entered in HH:MM:SS format. (**Note:** The time is in 24-hour format. For example, 5:30 A.M. appears as 05:30:00, and 5:30P.M. as 17:30:00.)

## 7-3 Advanced Settings

The Advanced Settings screen and submenus are listed below:

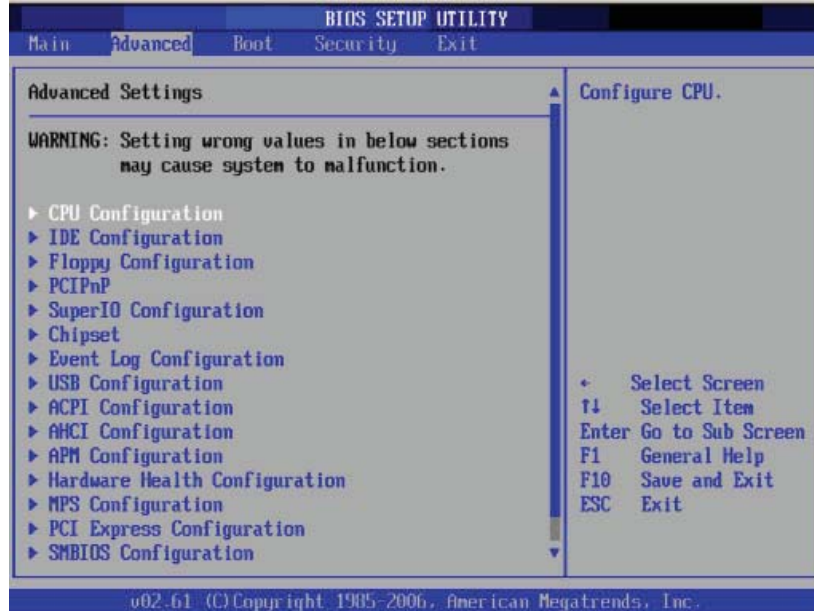

### **Warning**



When you first enter the Advanced Setup screen, the Setup Warning will be displayed. Please follow the instruction and set the correct value for each item to ensure proper system setup.

### ► CPU Configuration Submenu

#### Configure Advanced CPU Settings

This feature displays the settings of the processor(s) installed in the system.

#### **Ratio CMOS Setting** (Available when SpeedStep is disabled.)

This option allows the user to set the ratio between the CPU Core Clock and the FSB frequency. The default setting is 6.

#### **Hardware Prefetcher** (Available when supported by the OS and the CPU.)

If set to **Enabled**, the hardware prefetcher will prefetch streams of data and instructions from the main memory to the L2 cache in the forward or backward manner to improve CPU performance. The options are Disabled and **Enabled**.

#### **Adjacent Cache Line Prefetch** (Available when supported by the OS and the CPU.)

The CPU fetches the cache line for 64 bytes if this option is set to Disabled. The CPU fetches both cache lines for 128 bytes as comprised if Enabled. The options are Disabled and **Enabled**.

**Intel Virtualization Technology** (Available when supported by the OS and the CPU.)

Select Enabled to use the feature of Virtualization Technology to allow one platform to run multiple operating systems and applications in independent partitions, creating multiple "virtual" systems in one physical computer. The options are Enabled and **Disabled**. Note: If there is any change to this setting, you will need to power off and restart the system for the change to take effect. Please refer to Intel's web site for detailed information.

**Execute-Disable Bit Capability** (Available when supported by the OS and the CPU.)

Set to **Enabled** to enable the Execute Disable Bit feature to allow the processor to classify areas in the system memory where an application code can execute and where it cannot, thus preventing a worm or a virus from creating a flood of codes to overwhelm the processor or damage the system during an attack. **Note:** For more information regarding hardware/software support for this function, please refer to Intel's and Microsoft's web sites.

**Intel SpeedStep Technology** (Available when supported by the CPU.)

The Enhanced Intel SpeedStep Technology allows the system to automatically adjust processor voltage and core frequency in an effort to reduce power consumption and heat dissipation. Select Maximum to set the CPU speed to the maximum. Select Minimum to set the CPU speed to the minimum. Select Auto to allow the CPU speed to be controlled by the OS. Select **Disabled** to disable this feature. (Refer to Intel's web site for detailed information.)

## ►IDE Configuration Submenu

When this Submenu is selected, the AMI BIOS automatically displays the following items:

### **ATA/IDE Configuration**

This feature allows the user to configure the ATA/IDE mode. The options are Disabled, Compatible, and **Enhanced**.

#### **Configure SATA As**

This feature allows the user to configure the onboard SATA slots as IDE Drives, RAID Drives, or AHCI Drives. The options are **IDE**, RAID, and AHCI.

## **Primary IDE Channel Master/Slave, Secondary IDE Channel Master/Slave**

These settings allow the user to set the parameters of Primary IDE Channel Master/Slave and Secondary IDE Channel Master/Slave slots. Hit <Enter> to activate the following Submenu screen for detailed options of these items. Set the correct configurations accordingly. The items included in the Submenu are the following:

### **Type**

This feature allows the user to select the type of device connected to the system. The options are Not Installed, **Auto**, CDROM, and ARMD.

### **LBA/Large Mode**

Logical Block Addressing (LBA) is a method of addressing data on a disk drive. In the LBA mode, the maximum drive capacity is 137 GB. For drive capacities over 137 GB, your system must be equipped with a 48-bit LBA mode addressing. If not, contact your manufacturer or install an ATA/133 IDE controller card that supports 48-bit LBA mode. The options are Disabled and **Auto**.

### **Block (Multi-Sector Transfer)**

This feature allows the user to use the Block Mode to boost the IDE drive performance by increasing the amount of data transferred. Only 512 bytes of data can be transferred per interrupt if the Block Mode is not used. If the Block Mode is used, data will be transferred of up to 64 KB per interrupt. If set to Disabled, data will be transferred from and to the device one sector at a time. If set to Auto, data will be transferred from and to the device multiple sectors at a time if the device supports it. The options are **Auto** and Disabled.

### **PIO Mode**

The IDE PIO (Programmable I/O) Mode programs timing cycles between the IDE drive and the programmable IDE controller. As the PIO mode increases, the cycle time decreases. The options are **Auto**, 0, 1, 2, 3, and 4. Select Auto to allow the AMI BIOS to automatically detect the PIO mode. Use this value if the IDE disk drive support cannot be determined. Select 0 to allow the AMI BIOS to use PIO mode 0. It has a data transfer rate of 3.3 MBs. Select 1 to allow the AMI BIOS to use PIO mode 1. It has a data transfer rate of 5.2 MBs. Select 2 to allow the AMI BIOS to use PIO mode 2. It has a data transfer rate of 8.3 MBs. Select 3 to allow the AMI BIOS to use PIO mode 3. It has a data transfer rate of 11.1 MBs. Select 4 to allow the AMI BIOS to use PIO mode 4. It has a data transfer rate of 16.6 MBs. This setting generally works with all hard disk drives manufactured after 1999. For other disk drives, such as IDE CD-ROM drives, check the specifications of the drive.

## DMA Mode

Select **Auto** to allow the BIOS to automatically detect the DMA mode. Use this value if the IDE disk drive support cannot be determined. Select SWDMA0 to allow the BIOS to use Single Word DMA mode 0. It has a data transfer rate of 2.1 MBs. Select SWDMA1 to allow the BIOS to use Single Word DMA mode 1. It has a data transfer rate of 4.2 MBs. Select SWDMA2 to allow the BIOS to use Single Word DMA mode 2. It has a data transfer rate of 8.3 MBs. Select MWDMA0 to allow the BIOS to use Multi Word DMA mode 0. It has a data transfer rate of 4.2 MBs. Select MWDMA1 to allow the BIOS to use Multi Word DMA mode 1. It has a data transfer rate of 13.3 MBs. Select MWDMA2 to allow the BIOS to use Multi-Word DMA mode 2. It has a data transfer rate of 16.6 MBs. Select UDMA0 to allow the BIOS to use Ultra DMA mode 0. It has a data transfer rate of 16.6 MBs. It has the same transfer rate as PIO mode 4 and Multi Word DMA mode 2. Select UDMA1 to allow the BIOS to use Ultra DMA mode 1. It has a data transfer rate of 25 MBs. Select UDMA2 to allow the BIOS to use Ultra DMA mode 2. It has a data transfer rate of 33.3 MBs. Select UDMA3 to allow the BIOS to use Ultra DMA mode 3. It has a data transfer rate of 66.6 MBs. Select UDMA4 to allow the BIOS to use Ultra DMA mode 4. It has a data transfer rate of 100 MBs. The options are **Auto**, SWDMA<sub>n</sub>, MWDMA<sub>n</sub>, and UDMA<sub>n</sub>.

## S.M.A.R.T. For Hard disk drives

Self-Monitoring Analysis and Reporting Technology (SMART) can help predict impending drive failures. Select **Auto** to allow the AMI BIOS to automatically detect hard disk drive support. The options are Disabled, Enabled, and **Auto**.

## 32-Bit Data Transfer

Select **Enabled** to use the feature of 32-Bit data transfer. Select "Disabled" to disable this function. The options are **Enabled** and Disabled.

## Hard Disk Write Protect

Select **Enabled** to use the feature of Hard Disk Write Protect to prevent data from being written to HDD. The options are Enabled or **Disabled**.

## IDE Detect Time Out

This feature allows the user to set the system time-out value to allow the BIOS to detect the ATA, ATAPI devices installed in the system. The options are 0 (sec), 5, Mode 1.0, 15, 20, 25, 30, and **35**.

## ATA(PI) 80Pin Cable Detection

This feature allows the AMI BIOS to automatically detect 80Pin ATA(PI) Cable. The options are **Host & Device**, Host, and Device.

## ►Floppy Configuration

This option allows the user to configure the settings for the Floppy Drives installed in the system.

### Floppy A/Floppy B

Move the cursor to these fields via the up and down arrow keys to select the floppy type. The options are Disabled, 360 KB 5 1/4", 1.2 MB 5 1/4", 720 KB 3 1/2", **1.44 MB 3 1/2"**, and 2.88 MB 3 1/2".

## ►PCI/PnP Configuration

This feature allows the user to set the PCI/PnP configurations for the following items:

### Clear NVRAM

Select Yes to clear NVRAM during system boot. The options are Yes and **No**.

### Plug & Play OS

Select Yes to allow the OS to configure Plug & Play devices. (This is not required for system boot if your system has an OS that supports Plug & Play.) Select **No** to allow the AMI BIOS to configure all devices in the system.

### PCI Latency Timer

This feature sets the latency Timer of each PCI device installed on a PCI bus. The default setting is **64**. Select 32 to set the PCI latency to 32 PCI clock cycles. Select 64 to set the PCI latency to 64 PCI clock cycles. Select 96 to set the PCI latency to 96 PCI clock cycles. Select 128 to set the PCI latency to 128 PCI clock cycles. Select 160 to set the PCI latency to 160 PCI clock cycles. Select 192 to set the PCI latency to 192 PCI clock cycles. Select 224 to set the PCI latency to 224 PCI clock cycles. Select 248 to set the PCI latency to 248 PCI clock cycles.

### Allocate IRQ to PCI VGA

Select Yes to allow the system to give the VGA adapter card an interrupt address. The options are **Yes** and No.

### Palette Snooping

Select Enabled to inform the onboard PCI devices that an ISA graphics device is installed in the system in order for the graphics card to function properly. The options are Enabled and **Disabled**.

### PCI IDE BusMaster

Select Enabled to allow the BIOS to use the PCI busmaster to read from and write to the onboard IDE drives. The options are **Disabled** and Enabled.

### **Offboard PCI/ISA IDE Card**

This option allows the user to assign a PCI slot number to an off-board PCI/ISA IDE card in order for it to function properly. The options are **Auto**, PCI Slot1, PCI Slot2, PCI Slot3, PCI Slot4, PCI Slot5, and PCI Slot6.

### **IRQ3/IRQ4/IRQ5/IRQ7/IRQ9/IRQ10/IRQ11/IRQ14/IRQ15**

This feature specifies the availability of an IRQ to be used by a PCI, PnP device. Select Reserved for an IRQ to be used by a Legacy ISA device. The options are **Available** and Reserved.

### **DMA Channels 0~7**

Select Available to indicate that a specific DMA channel is available to be used by a PCI/PnP device. Select Reserved if a DMA channel specified is reserved for a Legacy ISA device.

### **Reserved Memory Size**

This feature specifies the size of memory block to be reserved for Legacy ISA devices. The options are **Disabled**, 16K, 32K, 64K.

## **►Super IO Configuration Submenu**

### **Onboard Floppy Controller**

Select Enabled to enable the onboard floppy controller. The options are **Enabled** and Disabled.

### **Serial Port1 Address/Serial Port2 Address**

This option specifies the base I/O port addresses and the Interrupt Request addresses for Serial Port 1 and Serial Port 2. Select Disabled to prevent the serial port from accessing any system resources. When set to Disabled, the serial port physically becomes unavailable. Select 3F8/IRQ4 to allow the serial port to use 3F8 as its I/O port address and IRQ 4 for the interrupt address. The options for Serial Port 1 are Disabled, **3F8/IRQ4**, 3E8/IRQ4, and 2E8/IRQ3. The options for Serial Port 2 are Disabled, **2F8/IRQ3**, 3E8/IRQ4 and 2E8/IRQ3.

### **Serial Port2 Mode**

This option allows the user to configure the Serial Port2 Mode. The Options are **Normal**, Sharp IR, SIR, and Consumer (-Configured).

## **►Advanced Chipset Settings**

This item allows the user to configure the Advanced Chipset settings for the system.

## ► NorthBridge Configuration

This feature allows the user to configure the NorthBridge Chipset settings.

### **Crystal Beach/DMA**

This feature uses the Intel I/O AT (Acceleration Technology) to accelerate the performance of TOE devices. **Note:** A TOE device is a specialized, dedicated processor that is installed on an add-on card or a network card to handle some or all packet processing of this add-on card. For this motherboard, the TOE device is built inside the ESB 2 South Bridge chip. The options are **Enabled** and Disabled.

### **MCH (Memory Controller Hub) Branch Mode**

This feature allows the user to decide how the two memory branches operate. System address space can either be interleaved between the two branches or sequencing from one branch to another. Mirror mode allows data correction by maintaining two copies of data in two branches. Single Channel 0 allows a single DIMM population during system manufacturing. The options are **Interleave**, Sequencing, Mirroring, and Single Channel 0.

### **Patrol Scrubbing**

Scrubbing is a process that allows the northbridge to correct correctable memory errors found on FBD memory modules. Select Enabled to use Patrol Scrubbing, a background ECC memory correction activity initiated by the northbridge to find and correct memory errors by scanning all memory modules doing simulated "READs" while checking for ECC errors. When an ECC error is detected during this process, it is logged as a Patrol error. A correctable error is corrected and written back into memory. The options are **Enabled** and Disabled.

### **Demand Scrubbing**

Scrubbing is a process that allows the northbridge to correct correctable memory errors found on an FBD memory module. When the CPU or I/O issues a demand- read command, and the read data from memory turns out to be a correctable ECC, it is corrected and sent to the original source. Memory is updated as well. Select Enabled to use Demand Scrubbing for ECC memory correction. The options are **Enabled** and Disabled.

### **Branch 0 Rank Sparing/Branch 1 Rank Sparing**

Select **Enable** to enable the sparing feature for Branch 0 or Branch 1 of the memory bus. The options are Enabled and **Disabled**.

### **Branch 0 Rank Interleaving/Branch 1 Rank Interleaving**

Select Enable to enable the functions of Memory Interleaving for Branch 0 Rank or Branch 1 Rank. The options for Memory Interleaving are 1:1, 2:1 and **4:1**.

### **FBD Thermal Throttle Mode**

Select Enabled to use the feature of closed-loop thermal throttling on a fully buffered (FBD) memory module. If Enabled, thermal throttling will be activated when the temperature of an FBD module reaches a predefined threshold. The default setting is **Enabled**.

### **Clock Spectrum Feature**

If Enabled, the BIOS will monitor the level of Electromagnetic Interference caused by the components and will attempt to decrease the interference whenever needed. The options are Enabled and **Disabled**.

### **Force ITK Configuration Clocking**

Select Enabled to configure FBD memory for ITK testing. The options are Enabled and **Disabled**.

### **ITK Branch**

Select an ITK Branch to be excluded from the BNB Memory Map. When set to 0, all memory modules installed on Branch 1 must support Lockstep Operation. The options are 0 and 1.

### **Boot Graphics Adapter Priority**

This feature allows the user to decide which graphics controller to be used as the primary boot device. The options are **Auto** and Onboard VGA.

### **Read Completion Coalescing**

This feature allows you to enable the PCI-Express Compliance Mode. The options are **Auto**, Disabled and Enabled.

### **Non-Compliance Mode**

Select the Compliance Mode to enable the PCI-Express Compliance Mode. The options are **Non-Compliance** and Compliance.

## **► SouthBridge Configuration**

This feature allows the user to configure the Intel ICH South Bridge settings.

### **SMBus Controller**

Select Enabled to activate the onboard SMBus (System Management Bus) controller. The options are **Enabled** and Disabled.

### **USB Functions**

This feature allows the user to decide the number of onboard USB ports to be enabled. The Options are: Disabled, 2 USB ports, 4 USB ports, and **6 USB ports**.

## USB2 Controller

Select Enabled to activate the onboard USB2 controller. The options are **Enabled** and Disabled.

## SLP\_S4# Minimum Assertion Width

This setting allows the user to select a desired length of time to be used as the SLP\_S4# Min. Assertion Width. The options are 4-5 Sec., 3-4 Sec., 2-3 Sec. and **1-2 Sec.**

## Restore on AC Power Loss

This setting allows you to decide how the system will react when power returns after an unexpected power loss. The options are Stay Off, Power On and **Last State.**

## PCI-E Port Configuration

### Slot#6 PCI-E x8

Select Auto to allow the BIOS to automatically configure PCI-E Slot#6 settings. The options are Disabled and **Auto.**

## ► ESB2 PCI-X Hub Configuration

### PCI Bus Frequency

This option allows the user to set the maximum PCI speed for the PCI slot specified. Select **Auto** to allow the BIOS to automatically detect the capability of the device installed on the bus. The options for Slot 1 are **Auto**, 33 MHz PCI, 66 MHz PCI, 66 MHz PCI-X, 100 MHz PCI-X, and 133 MHz PCI-X. The options for Slot 2 are **Auto**, 66 MHz PCI, 100 MHz PCI-X, and 133 MHz PCI-X.

### I/O Port Decode

This option allows the user to select the decode range for the I/O connections. The options are **4K Decode** and 1K Decode.

### RAS Sticky Error Handling

This option allows the user to decide how to handle Sticky RAS errors. The options are **Clear Errors** and Leave Errors (unchanged).

### VGA 16-Bit Decode

Select Enabled to enable the function of decoding VGA for the devices installed behind the PXH PCI Controller Hub. The options are **Enabled** and Disabled.

### IDTCV152 Spread Spectrum

Select Enable to enable IDTCV152 Spread Spectrum. The options are Enabled and **Disabled.**

## ►Event Log Configuration

Highlight this item and press <Enter> to view the contents of the event log.

### View Event Log

This feature allows the user to view all unread events.

### Mark All Events as Read

Highlight this item and press <Enter> to mark the DMI events as read.

### Clear Event Log

This setting will clear all event logs when set to OK. The options are OK and **Cancel**.

### ECC Event Logging

This setting allows you to **Enable** or Disable ECC event logging.

## ►USB Configuration

This feature allows the user to configure the USB settings.

### Legacy USB Support

Select Enabled to enable USB Legacy support. Disable legacy support if there are no USB devices installed in the system. The options are Disabled, **Enabled**, and Auto.

### USB 2.0 Controller Mode

This setting allows you to configure the USB 2.0 Controller Mode. The options are **Hi-Speed (480 Mbps)** and Full Speed-(12Mbps).

### BIOS EHCI Hand-Off

Select **Enabled** to halt the operation of the ECHI Host controller that is not supported by the Operating System during OHCI OS handover calls. The options are **Enabled** and Disabled.

### Hot Plug USB FDD Support

Set to Enabled to create a dummy FDD device to be used as a hot-plug FDD. Set to Auto for a hot-plug FDD device to be automatically created if a USB FDD is not detected. The options are **Auto**, Enabled and Disabled.

## ►USB Mass Storage Device Configuration

This feature allows the user to configure the USB Mass Storage Device settings.

### USB Mass Storage Device Reset Delay

This feature allows the user to set the time needed for the system to detect a specific USB Mass Storage Device before it executes the next command. The options are 10 Seconds, **20 Seconds**, 30 Seconds, and 40 Seconds.

### Emulation Type

This feature allows the user to configure the emulation type for the USB Mass Storage Device. If set to Auto, any USB device less than 530MB will be emulated as a floppy drive, and the remaining will be emulated as hard disk drives. The Forced FDD option can be used to force a HDD-formatted drive to boot as a floppy drive. The options are **Auto**, Floppy, Forced Floppy, HDD, and CD ROM.

## ►APCI Configuration

This item allows the user to enable or disable the ACPI support for the operating system.

## ►Advanced ACPI Configuration

Use this feature to configure advanced ACPI options. Select Yes if the operating system supports ACPI. Select No if the operating system does not support ACPI.

### ACPI Version Features

Select Yes to allow the RSDP pointers to point to the Fixed System Description Tables. Select No to deactivate this function. The options are Yes and **No**.

### ACPI APIC Support

Select Enabled to allow the ACPI APIC Table Pointer to be included in the RSDP pointer list. The options are **Enabled** and Disabled.

### AMI OEMB Table

Select Enabled to allow the OEMB Table Pointer to be included in the R(x)SDT pointer lists. The options are **Enabled** and Disabled.

### Headless Mode

Select Enabled to activate the Headless Operation Mode through the ACPI and allow the BIOS to boot up the system without using other I/O devices. The options are Enabled and **Disabled**.

## ► Chipset ACPI Configuration

### High Precision Event Time

Select Enabled to activate the High Precision Event Timer (HPET), which is capable of producing periodic interrupts at a much higher frequency than a Real-time Clock (RTC) can in synchronizing multimedia streams, providing smooth playback and reducing the dependency on other timestamp calculation devices, such as an x86 RDTSC Instruction embedded in a CPU. The High Precision Event Timer is used to replace the 8254 Programmable Interval Timer. The options for this feature are **Enabled** and Disabled.

## ► APM Configuration

This feature allows the user to configure the Advanced Power Management settings.

### Advanced Power Management (APM)

Select Enabled to use Advanced Power Management features. The options are **Enabled** and Disabled.

### Video Power Down Mode

If set to Suspend, video will go into the Suspend Mode when the system is in the Suspend or Standby Mode. The options are Disabled and **Suspend**.

### Hard Disk Power Down Mode

If set to Suspend, the onboard hard disk drives will go into the Suspend Mode when the system is in the Suspend or Standby Mode. The options are Disabled and **Suspend**.

### Suspend Time Out

If set to Disabled, the system will not go into the Suspend mode no matter how long it is inactive. If set to 1 Minute, the system will go into the Suspend mode if the system is inactive for more than 1 minute. The options are **Monitor** and Ignored.

### Keyboard and PS/2 Mouse Monitoring

Select Monitor to allow the keyboard and PS/2 Mouse to be monitored regularly. The options are 1, 2, 4, 8, 10, 20, 30, 40, 50, 60 (minutes), and Disabled.

### Power Button Mode

If set to On/Off, system power will be turned on/off when the user presses the power button. If set to the Suspend Mode, the system will go into the Suspend mode when the user presses the power button. The options are **On/Off** and Suspend.

## **Advanced Resume Event Control**

### **Resume On Ring**

If set to Enabled, the system will be "awakened" when the modem receives an incoming call. The options are Enabled and **Disabled**.

### **Resume On PME#**

Select Enabled to allow PME to generate a wake event. The options are **Enabled** and Disabled.

### **Resume On RTC Alarm**

Select Enabled to use the Real Time Clock (RTC) to set the timer for the system to be "awakened." The options are Enabled and **Disabled**.

## ► Hardware Health Configuration

This feature allows the AMI BIOS to automatically display the status of the following items:

### ► Temperatures

#### CPU Overheat Temperature

This feature allows the user to set the CPU Overheat temperature threshold. The options range from 65°C to 90°C. Use the <+> and <-> keys to set the desired setting. The default setting is **78°C**.

**The AMI BIOS will automatically monitor and display the following information:**

**CPU1 Temperature, CPU2 Temperature, CPU3 Temperature, CPU4 Temperature and System Temperature**

### ► Fan Speed

#### Fan Speed Control Modes

This feature allows the user to decide how the system controls the speeds of the onboard fans. The CPU temperature and the fan speed are correlative. When the CPU on-die temperature increases, the fan speed will also increase, and vice versa. If the option is set to 3-pin fan, the fan speed is controlled by voltage. If the option is set to 4-pin, the fan speed will be controlled by Pulse Width Modulation (PWM). Select 3-pin if your chassis came with 3-pin fan headers. Select 4-pin if your chassis came with 4-pin fan headers. Select Workstation if your system is used as a Workstation. Select Server if your system is used as a Server. Select Disable to disable the fan speed control function to allow the onboard fans to run at full speed (12V) at all times. The Options are: **1. Disable**, 2. 3-pin (Server), 3. 3-pin (Workstation), 4. 4-pin (Server) and 5. 4-pin (Workstation).

#### Fan1-Fan9 Speeds

### ► Voltage

#### Voltage Monitoring

CPU1-CPU4 Vcore, +3.3V, +5V, +12Vcc, -12Vcc, +3.3V Standby

**Note:** In the Windows OS environment, the Supero Doctor III settings take precedence over the BIOS settings. When first installed, Supero Doctor III adopts the temperature threshold settings previously set in the BIOS. Any subsequent changes to these thresholds must be made within Supero Doctor, since the SD III settings override the BIOS settings. For the Windows OS to adopt the BIOS temperature threshold settings, please change the SDIII settings to be the same as those set in the BIOS.

**►MPS Configuration**

This section allows the user to configure the multiprocessors table.

**MPS Revision**

This feature allows the user to select the MPS Revision. Please follow the instructions given on the screen to select the MPS Revision Number. The options are 1.1 and **1.4**.

**►PCI Express Configuration**

This section allows the user to configure the PCI Express slots.

**Active State Power Management**

Select Enabled to activate the function of power management for signal transactions between the PCI Express L0 and L1 Links. The options are Enabled and **Disabled**.

## ►SMBIOS Configuration

### SMBIOS SMI Support

Select Enabled to enable the function of SMBIOS SMI Wrapper support for PnP Func 50h-54h. The options are **Enabled** and Disabled.

## ►Remote Access Configuration

You can use this screen to select options for the Remote Access Configuration. Use the up and down arrow keys to select an item. Use the <+> and <-> keys to change the value of the selected option.

### Remote Access

This feature allows the user to enable the function of Remote Access. The options are Enabled and **Disabled**.

If the item "Remote Access" is set to Enabled, the following items will display:

#### **Serial Port Number**

This feature allows the user to select the serial port for Console Redirection. The options are **COM1** and COM2.

#### **Base Address, IRQ**

This feature allows the user to set the Base Address and IRQ settings for COM1 or COM2. The default setting for COM1 is **3F8h, 4**. The default setting for COM2 is **2F8h, 8**.

#### **Serial Port Mode**

This feature allows the user to set the serial port mode for Console Redirection. The options are **115200 8, N, 1**; 57600 8, N, 1; 38400 8, N, 1; 19200 8, N, 1; and 9600 8, N, 1.

#### **Flow Control**

This feature allows the user to set the flow control for Console Redirection. The options are **None**, Hardware, and Software.

#### **Redirection After BIOS POST**

Select Disabled to turn off Console Redirection after Power\_On\_Self\_Test (POST). Select **Always** to keep Console Redirection active all the time after POST. (**Note:** This setting may not be supported by some operating systems.) Select Boot Loader to keep Console Redirection active during POST and Boot Loader. The options are **Disabled**, Boot Loader, and Always.

### **Terminal Type**

This feature allows the user to select the target terminal type for Console Redirection. The options are **ANSI**, VT100, and VT-UTF8.

### **VT-UTF8 Comb Key Support**

This feature allows the user to select Enabled to enable the VT-UTF8 Combination Key support for the ANSI/VT100 Terminals. The options are **Enabled** and Disabled.

### **Sredir Memory Display Delay**

This feature allows the user to decide how many seconds the BIOS will wait before memory information is displayed. The options are **No Delay**, Delay 1 Sec., Delay 2 Sec.; and Delay 4 Sec.

## **►Trusted Computing**

### **TCG/TPM Support**

This feature allows the user to enable or disable TPM/TCG (TPM 1.1/1.2) support in the BIOS. The options are Yes and **No**.

## 7-4 Boot Configuration

This feature allows the user to configure the following items:



### ► Boot Settings

#### Quick Boot

If Enabled, this option will skip certain tests during POST to reduce the time needed for system bootup. The options are **Enabled** and Disabled.

#### Quiet Boot

This option allows the bootup screen options to be modified between POST messages or the OEM logo. Select **Disabled** to allow the computer system to display the POST messages. Select Enabled to allow the computer system to display the OEM logo.

#### Add-On ROM Display Mode

This option allows the BIOS to display add-on ROM (read-only memory) messages. Select **Force BIOS** to display a third party BIOS during system boot. Select "Keep Current" to display the current BIOS information during system boot.

#### Bootup Num-Lock

This option allows the Number Lock setting to be modified during bootup. The default setting is **On**. The options are On and Off.

#### PS/2 Mouse Support

This option allows the PS/2 mouse support to be modified. The options are **Auto**, Enabled and Disabled.

### **Parity Checking**

This option allows the user to enable or disable SB IDCHK# and PCI SERR# Parity Checking. The options are Enabled and **Disabled**.

### **Wait for 'F1' If Error**

Select Enable to allow the system to wait for the user to press F1 when an error occurs. The options are **Enabled** and Disabled.

### **Hit 'DEL' Message Display**

Select Enabled to display the Setup Message: "Press DEL to run Setup" when the user hits the DEL key. The options are **Enabled** and Disabled.

### **Interrupt 19 Capture**

Select Enabled to allow Option ROMs to trap Interrupt 19. The options are Enabled and **Disabled**.

### **Boot Graphic Adapter Priority**

This feature allows the user to select which graphics controller to be used as the primary boot device. The options are **Auto** and Onboard VGA.

### **Watch Dog Timer**

If enabled, this option will automatically reset the system if the system is not active for more than 5 minutes. The options are Enabled and **Disabled**.

### **►Boot Device Priority**

This feature allows the user to specify the sequence of priority for the Boot Device.

The settings are 1st Floppy Drive, CD ROM, ATAPI CDROM and Disabled. The default settings are the following:

- 1st boot device – 1st Floppy Drive
- 2nd boot device – Network: IBA GE Slot
- 3rd boot device – Network: IBA GE Slot

### **►Hard Disk Drive**

This feature allows the user to specify the boot sequence from available HDDs.

#### **1st Drive**

This option allow the user to specify the boot sequence for the first HDD.

- 1st boot device

## ► Removable Drives

This feature allows the user to specify the boot sequence from available Removable Drives.

### **1st Drive/2nd Drive**

This option allow the user to specify the boot sequence for the first Removable Drive and the second Removable Drive.

The options are **1st Floppy Drive**, USB: Pepper Virtual Disc 1 (2nd Drive), and Disabled.

## ► CD/DVD Drives

This feature allows the user to specify the boot sequence from available CD/DVD-Drives.

### **1st Drive/2nd Drive**

This option allows the user to specify the boot sequence for the First CD/DVD Drive and the Second CD/DVD Drive. The options are CD/DVD: PS-UJDA770, CD/DVD and Disabled.

## 7-5 Security Settings

The AMI BIOS provides a Supervisor and a User password. If you use both passwords, the Supervisor password must be set first.

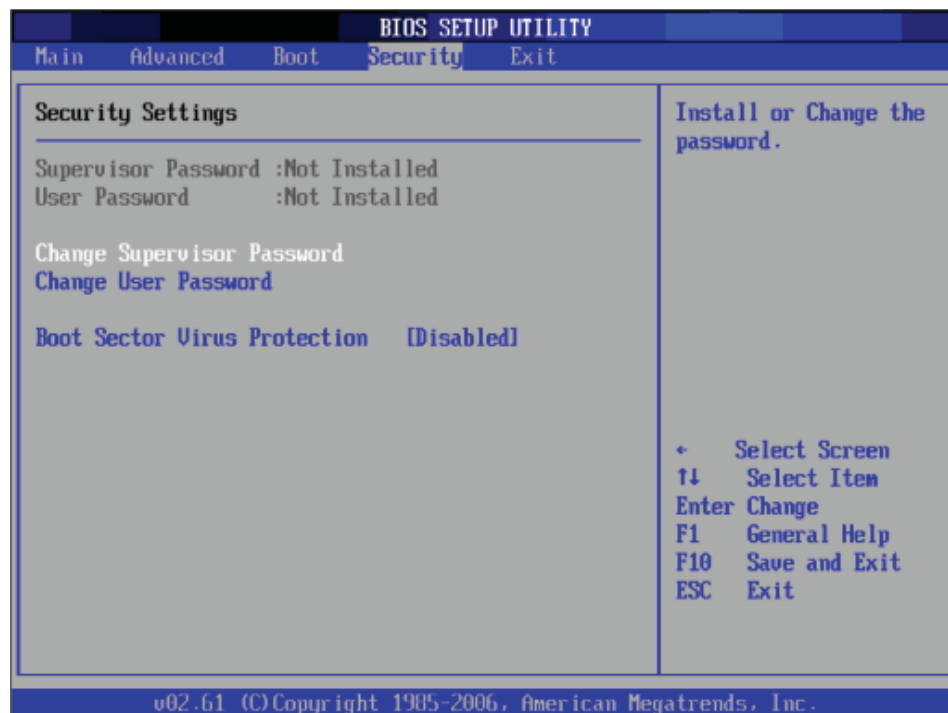

### Change Supervisor Password

Select this option and press <Enter> to access the Submenu, and then type in the password.

### Change User Password

Select this option and press <Enter> to access the Submenu, and then type in the password.

### Clear User Password

This option allows the user to clear a password that has been previously entered into the system.

### Password Check

Set to **Setup** to allow the system to perform a password check when the BIOS Setup is invoked. Set to **Always** to allow the system to perform a password check when the BIOS Setup is invoked or when the system boots up.

### Boot Sector Virus Protection

This option is near the bottom of the Security Setup screen. Select "Disabled" to deactivate the Boot Sector Virus Protection. Select "Enabled" to enable boot sector protection. When Enabled, the AMIBIOS displays a warning when any program (or virus) issues a Disk Format command or attempts to write to the boot sector of the hard disk drive. The options are **Enabled** and **Disabled**.

## 7-6 Exit Options

Select the Exit tab from the AMIBIOS Setup Utility screen to enter the Exit BIOS Setup screen.

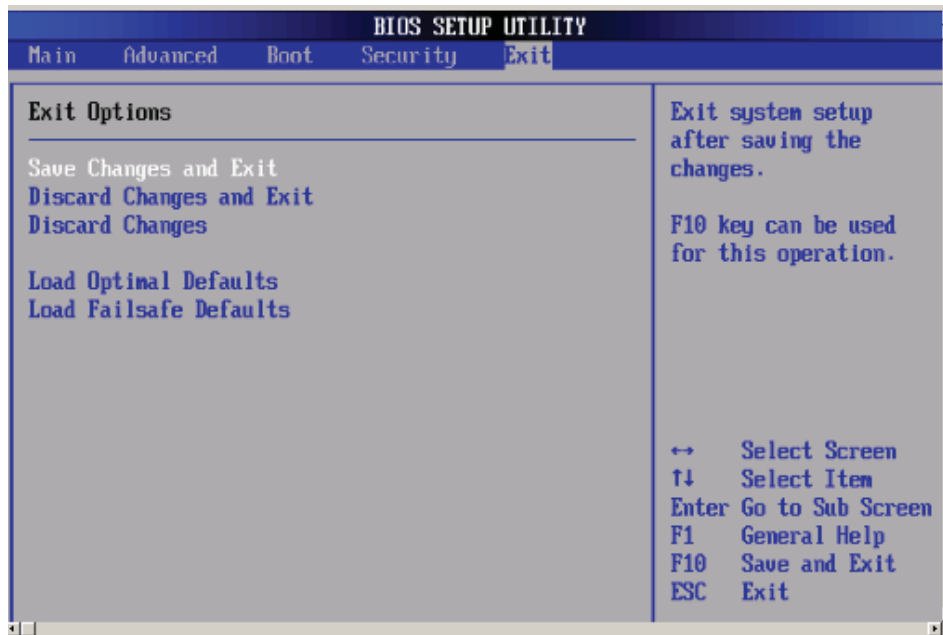

### Saving Changes and Exit

When you have completed the system configuration changes, select this option to leave the BIOS Setup and reboot the computer, so the new system configuration parameters can take effect. Select Save Changes and Exit from the Exit menu and press <Enter>.

### Discarding Changes and Exit

Select this option to quit the BIOS Setup without making any permanent changes to the system configuration and reboot the computer. Select Discard Changes and Exit from the Exit menu and press <Enter>.

### Discarding Changes

Select this option and press <Enter> to discard all the changes and return to the AMIBIOS Utility Program.

### Load Optimal Defaults

To set this feature, select Load Optimal Defaults from the Exit menu and press <Enter>. Then, Select "OK" to allow the AMI BIOS to automatically load Optimal Defaults to the BIOS Settings. The Optimal settings are designed for maximum system performance, but may not work best for all computer applications.

**Load Fail-Safe Defaults**

To set this feature, select Load Fail-Safe Defaults from the Exit menu and press <Enter>. The Fail-Safe settings are designed for maximum system stability, but not for maximum performance.

**Notes**

## Appendix A

### BIOS POST Messages

During the Power-On Self-Test (POST), the BIOS will check for problems. If a problem is found, the BIOS will activate an alarm or display a message. The following is a list of such BIOS messages.

**Failure Fixed Disk**

Fixed disk is not working or not configured properly. Check to see if fixed disk is attached properly. Run Setup. Find out if the fixed-disk type is correctly identified.

**Stuck key**

Stuck key on keyboard.

**Keyboard error**

Keyboard not working.

**Keyboard Controller Failed**

Keyboard controller failed test. May require replacing keyboard controller.

**Keyboard locked - Unlock key switch**

Unlock the system to proceed.

**Monitor type does not match CMOS - Run SETUP**

Monitor type not correctly identified in Setup

**Shadow Ram Failed at offset: nnnn**

Shadow RAM failed at offset **nnnn** of the 64k block at which the error was detected.

**System RAM Failed at offset: nnnn**

System RAM failed at offset **nnnn** of in the 64k block at which the error was detected.

**Extended RAM Failed at offset: nnnn**

Extended memory not working or not configured properly at offset **nnnn**.

**System battery is dead - Replace and run SETUP**

The CMOS clock battery indicator shows the battery is dead. Replace the battery and run Setup to reconfigure the system.

**System CMOS checksum bad - Default configuration used**

System CMOS has been corrupted or modified incorrectly, perhaps by an application program that changes data stored in CMOS. The BIOS installed Default Setup Values. If you do not want these values, enter Setup and enter your own values. If the error persists, check the system battery or contact your dealer.

**System timer error**

The timer test failed. Requires repair of system board.

**Real time clock error**

Real-Time Clock fails BIOS hardware test. May require board repair.

**Check date and time settings**

BIOS found date or time out of range and reset the Real-Time Clock. May require setting legal date (1991-2099).

**Previous boot incomplete - Default configuration used**

Previous POST did not complete successfully. POST loads default values and offers to run Setup. If the failure was caused by incorrect values and they are not corrected, the next boot will likely fail. On systems with control of **wait states**, improper Setup settings can also terminate POST and cause this error on the next boot. Run Setup and verify that the waitstate configuration is correct. This error is cleared the next time the system is booted.

**Memory Size found by POST differed from CMOS**

Memory size found by POST differed from CMOS.

**Diskette drive A error**

Drive A: is present but fails the BIOS POST diskette tests. Check to see that the drive is defined with the proper diskette type in Setup and that the diskette drive is attached correctly.

**Incorrect Drive A type - run SETUP**

Type of floppy drive A: not correctly identified in Setup.

**System cache error - Cache disabled**

RAM cache failed and BIOS disabled the cache. On older boards, check the cache jumpers. You may have to replace the cache. See your dealer. A disabled cache slows system performance considerably.

**CPU ID:**

CPU socket number for Multi-Processor error.

**EISA CMOS not writeable**

ServerBIOS2 test error: Cannot write to EISA CMOS.

**DMA Test Failed**

ServerBIOS2 test error: Cannot write to extended **DMA** (Direct Memory Access) registers.

**Software NMI Failed**

ServerBIOS2 test error: Cannot generate software NMI (Non-Maskable Interrupt).

**Fail-Safe Timer NMI Failed**

ServerBIOS2 test error: Fail-Safe Timer takes too long.

**Device Address Conflict**

Address conflict for specified **device**.

**Allocation Error for: device**

Run ISA or EISA Configuration Utility to resolve resource conflict for the specified **device**.

**CD ROM Drive**

CD ROM Drive identified.

**Entering SETUP ...**

Starting Setup program

**Failing Bits: nnnn**

The hex number **nnnn** is a map of the bits at the RAM address which failed the memory test. Each 1 (one) in the map indicates a failed bit. See errors 230, 231, or 232 above for offset address of the failure in System, Extended, or Shadow memory.

**Fixed Disk n**

Fixed disk **n** (0-3) identified.

**Invalid System Configuration Data**

Problem with NVRAM (CMOS) data.

**I/O device IRQ conflict**

I/O device IRQ conflict error.

**PS/2 Mouse Boot Summary Screen:**

PS/2 Mouse installed.

**nnnn kB Extended RAM Passed**

Where **nnnn** is the amount of RAM in kilobytes successfully tested.

**nnnn Cache SRAM Passed**

Where **nnnn** is the amount of system cache in kilobytes successfully tested.

**nnnn kB Shadow RAM Passed**

Where **nnnn** is the amount of shadow RAM in kilobytes successfully tested.

**nnnn kB System RAM Passed**

Where **nnnn** is the amount of system RAM in kilobytes successfully tested.

**One or more I2O Block Storage Devices were excluded from the Setup Boot Menu**

There was not enough room in the IPL table to display all installed I2O block-storage devices.

**Operating system not found**

Operating system cannot be located on either drive A: or drive C:. Enter Setup and see if fixed disk and drive A: are properly identified.

**Parity Check 1 nnnn**

Parity error found in the system bus. BIOS attempts to locate the address and display it on the screen. If it cannot locate the address, it displays **????**. Parity is a method for checking errors in binary data. A parity error indicates that some data has been corrupted.

**Parity Check 2 nnnn**

Parity error found in the I/O bus. BIOS attempts to locate the address and display it on the screen. If it cannot locate the address, it displays **????**.

**Press <F1> to resume, <F2> to Setup, <F3> for previous**

Displayed after any recoverable error message. Press <F1> to start the boot process or <F2> to enter Setup and change the settings. Press <F3> to display the previous screen (usually an initialization error of an **Option ROM**, i.e., an add-on card). Write down and follow the information shown on the screen.

**Press <F2> to enter Setup**

Optional message displayed during POST. Can be turned off in Setup.

**PS/2 Mouse:**

PS/2 mouse identified.

**Run the I2O Configuration Utility**

One or more unclaimed block storage devices have the Configuration Request bit set in the LCT. Run an I2O Configuration Utility (e.g. the SAC utility).

**System BIOS shadowed**

System BIOS copied to shadow RAM.

**UMB upper limit segment address: *nnnn***

Displays the address *nnnn* of the upper limit of **Upper Memory Blocks**, indicating released segments of the BIOS which can be reclaimed by a virtual memory manager.

**Video BIOS shadowed**

Video BIOS successfully copied to shadow RAM.

**Notes**

## Appendix B

### BIOS POST Codes

This section lists the POST (Power On Self Test) codes for the Phoenix BIOS. POST codes are divided into two categories: recoverable and terminal.

#### ***Recoverable POST Errors***

When a recoverable type of error occurs during POST, the BIOS will display a POST code that describes the problem. BIOS may also issue one of the following beep codes:

- 1 long and two short beeps - video configuration error
- 1 repetitive long beep - no memory detected

#### ***Terminal POST Errors***

If a terminal error occurs, BIOS will shut down the system but first will write the error to port 80h, attempt to initialize video and write the error in the top left corner of the screen. The following is a list of codes that may be written to port 80h.

<b>POST Code</b>	<b>Description</b>
01h	IPMI Initialization
02h	Verify Real Mode
03h	Disable Non-Maskable Interrupt (NMI)
04h	Get CPU type
06h	Initialize system hardware
07h	Disable shadow and execute code from the ROM.
08h	Initialize chipset with initial POST values
09h	Set IN POST flag
0Ah	Initialize CPU registers
0Bh	Enable CPU cache
0Ch	Initialize caches to initial POST values
0Eh	Initialize I/O component
0Fh	Initialize the local bus IDE
10h	Initialize Power Management
11h	Load alternate registers with initial POST values
12h	Restore CPU control word during warm boot
13h	Reset PCI Bus Mastering devices

<b>POST Code</b>	<b>Description</b>
14h	Initialize keyboard controller
16h	1-2-2-3 BIOS ROM checksum
17h	Initialize cache before memory Auto size
18h	8254 timer initialization
1Ah	8237 DMA controller initialization
1Ch	Reset Programmable Interrupt Controller
20h	1-3-1-1 Test DRAM refresh
22h	1-3-1-3 Test 8742 Keyboard Controller
24h	Set ES segment register to 4 GB
28h	Auto size DRAM
29h	Initialize POST Memory Manager
2Ah	Clear 512 kB base RAM
2Ch	1-3-4-1 RAM failure on address line <b>xxxx*</b>
2Eh	1-3-4-3 RAM failure on data bits <b>xxxx*</b> of low byte of memory bus
2Fh	Enable cache before system BIOS shadow
32h	Test CPU bus-clock frequency
33h	Initialize Phoenix Dispatch Manager
36h	Warm start shut down
38h	Shadow system BIOS ROM
3Ah	Auto size cache
3Ch	Advanced configuration of chipset registers
3Dh	Load alternate registers with CMOS values
41h	Initialize extended memory for RomPilot (optional)
42h	Initialize interrupt vectors
45h	POST device initialization
46h	2-1-2-3 Check ROM copyright notice
48h	Check video configuration against CMOS
49h	Initialize PCI bus and devices
4Ah	Initialize all video adapters in system
4Bh	QuietBoot start (optional)
4Ch	Shadow video BIOS ROM
4Eh	Display BIOS copyright notice
4Fh	Initialize MultiBoot
50h	Display CPU type and speed
51h	Initialize EISA board (optional)
52h	Test keyboard
54h	Set key click if enabled
55h	Enable USB devices
58h	2-2-3-1 Test for unexpected interrupts
59h	Initialize POST display service
5Ah	Display prompt "Press <ESC> to enter SETUP"

---

<b>POST Code</b>	<b>Description</b>
5Bh	Disable CPU cache
5Ch	Test RAM between 512 and 640 kB
60h	Test extended memory
62h	Test extended memory address lines
64h	Jump to UserPatch1
66h	Configure advanced cache registers
67h	Initialize Multi Processor APIC
68h	Enable external and CPU caches
69h	Setup System Management Mode (SMM) area
6Ah	Display external L2 cache size
6Bh	Load custom defaults (optional)
6Ch	Display shadow-area message
70h	Display error messages
72h	Check for configuration errors
76h	Check for keyboard errors
7Ch	Set up hardware interrupt vectors
7Dh	Initialize Intelligent System Monitoring (optional)
7Eh	Initialize coprocessor if present
80h	Disable onboard Super I/O ports and IRQs (optional)
81h	Late POST device initialization
82h	Detect and install external RS232 ports
83h	Configure non-MCD IDE controllers
84h	Detect and install external parallel ports
85h	Initialize PC-compatible PnP ISA devices
86h	Re-initialize onboard I/O ports.
87h	Configure Motherboard Configurable Devices (optional)
88h	Initialize BIOS Data Area
89h	Enable Non-Maskable Interrupts (NMIs)
8Ah	Initialize Extended BIOS Data Area
8Bh	Test and initialize PS/2 mouse
8Ch	Initialize floppy controller
8Fh	Determine number of ATA drives (optional)
90h	Initialize hard-disk controllers
91h	Initialize local-bus hard-disk controllers
92h	Jump to UserPatch2
93h	Build MPTABLE for multi-processor boards
95h	Install CD ROM for boot
96h	Clear huge ES segment register
97h	Fix up Multi Processor table
98h	1-2 Search for option ROMs and shadow if successful. One long, two short beeps on checksum failure

---

<b>POST Code</b>	<b>Description</b>
99h	Check for SMART Drive (optional)
9Ch	Set up Power Management
9Dh	Initialize security engine (optional)
9Eh	Enable hardware interrupts
9Fh	Determine number of ATA and SCSI drives
A0h	Set time of day
A2h	Check key lock
A4h	Initialize typematic rate
A8h	Erase <ESC> prompt
AAh	Scan for <ESC> key stroke
ACh	Enter SETUP
AEh	Clear Boot flag
B0h	Check for errors
B1h	Inform RomPilot about the end of POST (optional)
B2h	POST done - prepare to boot operating system
B4h	1 One short beep before boot
B5h	Terminate QuietBoot (optional)
B6h	Check password (optional)
B7h	Initialize ACPI BIOS and PPM Structures
B9h	Prepare Boot
BAh	Initialize SMBIOS
BCh	Clear parity checkers
BDh	Display MultiBoot menu
BEh	Clear screen (optional)
BFh	Check virus and backup reminders
C0h	Try to boot with INT 19
C1h	Initialize POST Error Manager (PEM)
C2h	Initialize error logging
C3h	Initialize error display function
C4h	Initialize system error flags
C6h	Console redirection init.
C7h	Unhook INT 10h if console redirection enabled
C8h	Force check (optional)
C9h	Extended ROM checksum (optional)
CDh	Reclaim console redirection vector
D2h	Unknown interrupt
D4h	Check Intel Branding string
D8h	Alert Standard Format initialization
D9h	Late init for IPMI
DEh	Log error if micro-code not updated properly

---

**The following are for the boot block in Flash ROM**

<b>POST Code</b>	<b>Description</b>
E0h	Initialize the chipset
E1h	Initialize the bridge
E2h	Initialize the CPU
E3h	Initialize system timer
E4h	Initialize system I/O
E5h	Check force recovery boot
E6h	Checksum BIOS ROM
E7h	Go to BIOS
E8h	Set Huge Segment
E9h	Initialize Multi Processor
EAh	Initialize OEM special code
EBh	Initialize PIC and DMA
ECh	Initialize Memory type
EDh	Initialize Memory size
EEh	Shadow Boot Block
EFh	System memory test
F0h	Initialize interrupt vectors
F1h	Initialize Run Time Clock
F2h	Initialize video
F3h	Initialize System Management Manager
F4h	Output one beep
F5h	Clear Huge Segment
F6h	Boot to Mini DOS
F7h	Boot to Full DOS

**Note:** If the BIOS detects errors on 2C, 2E, or 30 (base 512K RAM error), it displays an additional word-bitmap (**xxxx**) indicating the address line or bits that have failed. For example, "2C 0002" means address line 1 (bit one set) has failed. "2E 1020" means data bits 12 and 5 (bits 12 and 5 set) have failed in the lower 16 bits. The BIOS also sends the bitmap to the port-80 LED display. It first displays the checkpoint code, followed by a delay, the high-order byte, another delay, and then the low-order byte of the error. It repeats this sequence continuously.

**Notes**

## Appendix C

### HostRAID Setup Guidelines

After all the hardware has been installed, you must first configure Intel's ESB2 SATA RAID before you install the Windows Operating System and other software drivers.

#### Important Notes

Note 1: If you do not wish to configure onboard SATA RAID functions, please go directly to Section C-2 for the OS & other software installation.

Note 2: This chapter describes RAID configuration instructions for the Intel ESB2 Host RAID Controller designed for the Windows OS. To configure the LSI SAS HostRAID, please refer to the LSI folder for the LSI SAS HostRAID Utility and documentation. The LSI folder is included in the CD-ROM that came with your motherboard.

#### C-1 Introduction to Serial ATA and Parallel ATA

To configure the SATA RAID functions, you must first use the Intel ESB2 SATA RAID Utility program to configure the RAID Level that you desire before installing the Windows XP/2000/2003 operating system and other software drivers. (The necessary drivers are all included on the Supermicro CD that came packaged with your motherboard.) Note that the current version of the ESB2 SATA RAID Utility can only support Windows XP/2000/2003 Operating Systems.

#### Serial ATA (SATA)

Serial ATA (SATA) is a physical storage interface that uses a single cable with a minimum of four wires to create a point-to-point connection between devices. It is a serial link, which supports transfer rates up to 3.0 Gbps. Because the serial cables used in SATA are thinner than the traditional cables used in Parallel ATA (PATA), SATA systems have better airflow and can be installed in smaller chassis. In addition, the cables used in PATA are limited to a length of 40cm, while Serial ATA cables can be up to one meter in length. Overall, SATA provides better functionality than PATA.

#### Intel ESB2 Serial RAID

Located in the South Bridge of the 7300 chipset, the I/O Controller Hub (ESB2) provides the I/O subsystem with access to the rest of the system. It supports 1-channel UltraATA/100 Bus Master IDE controller (PATA) and four Serial ATA (SATA) ports. The ESB2 supports the following PATA and SATA device configurations: Legacy mode and Native mode.

### ***The Intel HostRAID Configurations***

The following types of Intel's HostRAID configurations are supported:

RAID 0 (Data Striping): this writes data in parallel, interleaved ("striped") sections of two hard drives. Data transfer rate is doubled over using a single disk.

RAID1 (Data Mirroring): an identical data image from one drive is copied to another drive. The second drive must be the same size or larger than the first drive.

RAID 10 (Striping & Mirroring): RAID 0 and 1 schemes are combined (without parity information) to get the benefits of both.

RAID 5: both data and parity information are striped and mirrored across three or more hard drives.

### ***The Intel Matrix Storage***

The Intel Matrix Storage, supported by the ESB2, allows the user to create RAID 0, RAID 1, RAID 10 and RAID 5 sets by using only four identical hard disk drives. The Intel Matrix Storage Technology creates two partitions on each hard disk drive and generate a virtual RAID 0, RAID 1, RAID 10 and RAID 5 sets. It also allows you the change the HDD partition size without any data.

### ***Configuring BIOS Settings***

1. Press the <Del> key during system bootup to enter the BIOS Setup Utility.  
**Note:** If it is the first time powering on the system, we recommend you load the Optimized Default Settings. If you have already done so, please skip to Step 3.
2. Use the arrow keys to select the "Exit" Settings. Once in the "Exit" settings, Scroll down to select "Load Optimized Default Settings" and press the <Enter> key. Select "OK" to confirm the selection. Press the <Enter> key to load the default settings for the BIOS.
3. Use the arrow keys to select the "Main" section in BIOS.
4. Scroll down to "SATA Controller Mode" and press the <Enter> key to select "Enhanced"

5. Scroll down to "SATA RAID Enabled" and press <Enter>. Then, select "Enabled."
6. Scroll down to "Exit". Select "Save and Exit" from the "Exit" menu. Press the <Enter> key to save the changes and exit the BIOS.
7. Once you've exited the BIOS Utility, the system will re-boot.
8. During the system boot-up, press the <Ctrl> and <I> keys simultaneously to run the Intel RAID Configuration Utility when prompted by the following message: *Press <Ctrl> <I> for the Intel RAID Configuration Utility.* **Note:** The Intel RAID Configuration Utility is only available for systems with two or more drives installed. The Intel RAID Utility screen will not display in systems with one drive installed.

## Using the Intel ESB2 SATA RAID Utility Program

### *Creating, Deleting and Resetting RAID Volumes:*

1. After the system exits from the BIOS Setup Utility, the system will automatically reboot. The following screen appears after Power-On Self Test.

```

RAID Volumes :
None defined.

Physical Disks :
Port Drive Model      Serial #              Size   Type/Status(Vol ID)
0   WDC WD2500SD-01K  WD-WMAL72034971      232.9GB Non-RAID Disk
1   WDC WD2500SD-01K  WD-WMAL72034599      232.9GB Non-RAID Disk
2   WDC WD2500JD-00F  WD-WMAEH1376109      232.9GB Non-RAID Disk
3   WDC WD2500JD-00F  WD-WMAEH1449527      232.9GB Non-RAID Disk

Press <CTRL-I> to enter Configuration Utility...

Adaptec SCSI BIOS v4.30.0
Copyright 2003 Adaptec, Inc. All Rights Reserved.

<<< Press <Ctrl><A> for SCSISelect(TM) Utility! >>>

Slot Ch ID LUN  Vendor      Product              Size  Bus Status
-----
04  A  10  0

```

2. When you see the above screen, press the <Ctrl> and the <I> keys simultaneously to have the main menu of the SATA RAID Utility appear:

**Note:** All graphics and screen shots shown in the manual are for reference only. The screen shots shown in the manual do not imply Supermicro's endorsement or non-endorsement on any 3rd party's product.

### Creating a RAID 0 Volume

1. Select "Create RAID Volume" from the main menu and press the <Enter> key. The following screen will appear:



2. Specify a name for the RAID 0 set and press the <Tab> key or the <Enter> key to go to the next field. (The <Esc> key takes you to the previous menu.)
3. When "RAID Level" is highlighted, press the <Up Arrow> <Down Arrow> keys to select RAID 0 (Stripe) and hit <Enter>.
4. When the "Disks" item is highlighted, press <Enter> to select the HDD to configure as RAID. The following pop-up screen displays:

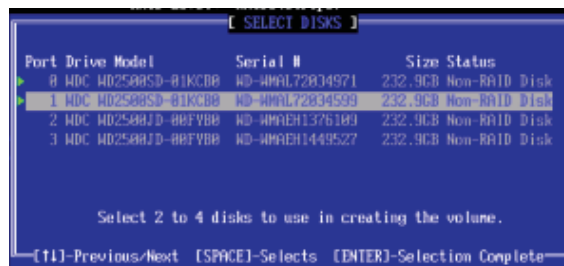

5. Use the <Up Arrow>, <Down Arrow> keys to highlight a drive and press <Space> to select it. A triangle appears to confirm the selection of the drive.
6. Use the <Up Arrow>, <Down Arrow> keys to select the stripe size, ranging from 4 KB to 128 KB for the RAID 0 array, and hit <Enter>. **Note:** For a server, please use a lower stripe size, and for a multimedia system, use a higher stripe size. The default stripe size is 128 KB.

7. Press <Enter> when the Create Volume item is highlighted. A warning message displays.
8. When asked "Are you sure you want to create this volume (Y/N)", press "Y" to create the RAID volume, or type "N" to go back to the Create Volume menu.

### **Creating a RAID 1 Volume:**

1. Select "Create RAID Volume" from the main menu and press the <Enter> key. The following screen will appear:

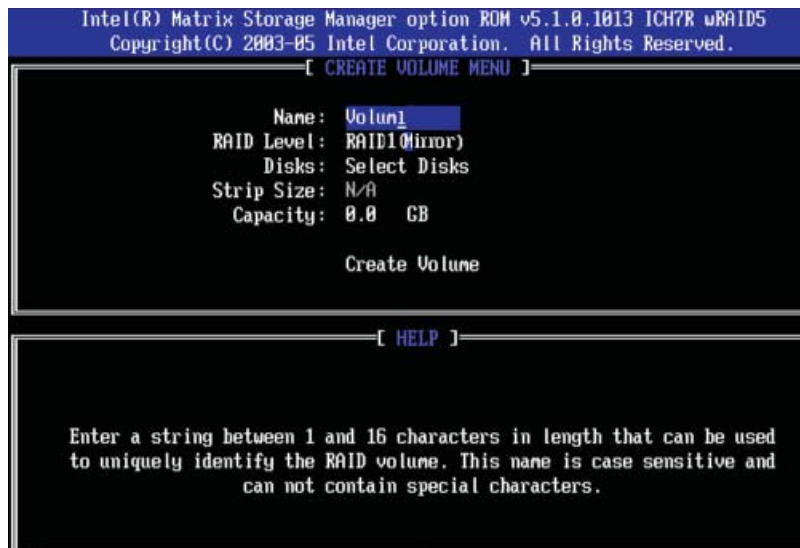

2. Specify a name for the RAID 1 set and press the <Tab> key or the <Enter> key to go to the next field. You can use the <Esc> key to select the previous menu.
3. When "RAID Level" item is highlighted, press the <Up Arrow> <Down Arrow> keys to select RAID 1 (Mirror) and hit <Enter>.
4. When the "Capacity" item is highlighted, enter your RAID volume capacity and hit <Enter>. The default setting is the maximum capacity allowed.
5. Press <Enter> with the Create Volume item is highlighted. A warning message displays.
6. When asked "Are you sure you want to create this volume (Y/N)?", press <Y> to create the RAID volume or <N> to go back to the Create Volume menu.

### Creating a RAID 10 (RAID 1+ RAID 0)

1. Select "Create RAID Volume" from the main menu and press the <Enter> key. The following screen will appear:

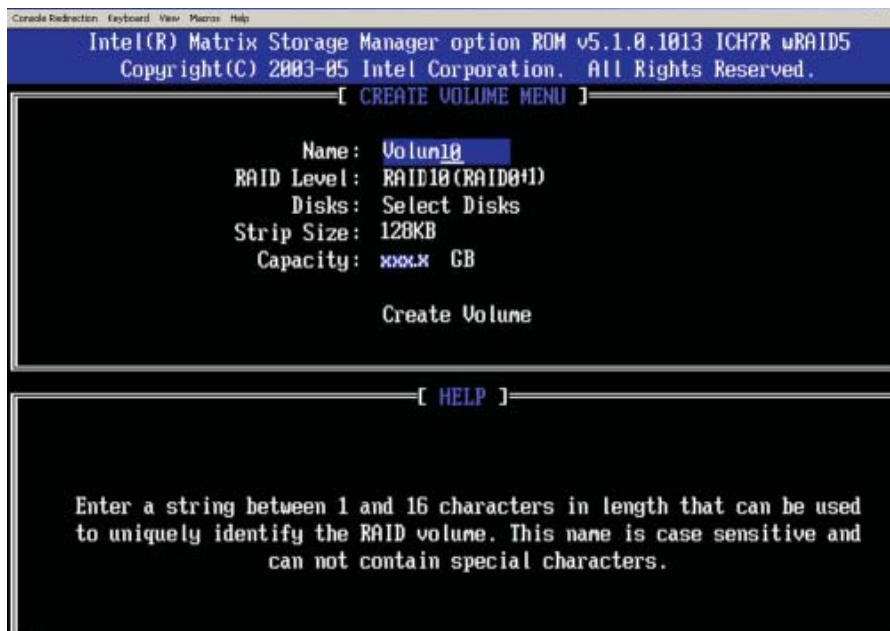

2. Specify a name for the RAID 10 set and press <Enter>.
3. When "RAID Level" item is highlighted, use the <Up Arrow> <Down Arrow> keys to select RAID 10 (RAID1 + RAID0) and hit <Enter>.
4. When "Stripe Size" is highlighted, use the <Up Arrow> <Down Arrow> keys to select the stripe size from 4 KB to 128 KB for your RAID 10 and hit <Enter>. The default setting is 64 KB. **Note:** For a server, please use a lower stripe size, and for a multimedia system, use a higher stripe size.
5. When the "RAID Volume Capacity" item is highlighted, enter your RAID volume capacity and hit <Enter>. The default setting is the maximum capacity allowed.
6. Press <Enter> when the "Create Volume" item is highlighted. A warning message displays.
7. When asked "Are you sure you want to create this volume (Y/N)?", press <Y> to create the RAID volume or <N> to go back to the Create Volume menu.

### Creating a RAID 5 Set (Parity)

1. Select "Create RAID Volume" from the main menu and press the <Enter> key. The following screen will appear:

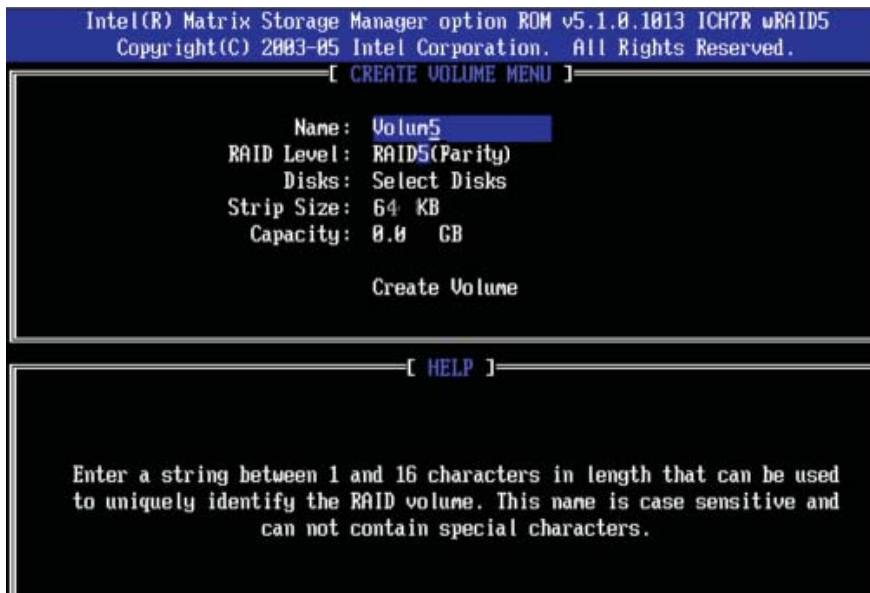

2. Specify a name for the RAID 5 set and press <Enter>.
3. When "RAID Level" is highlighted, use the <Up Arrow> <Down Arrow> keys to select RAID 5 (Parity) and hit <Enter>.
4. When "Disk Item" is highlighted, press <Enter> to select the HDD to configure as a RAID. The following pop-up screen (see note on page C-3) displays:

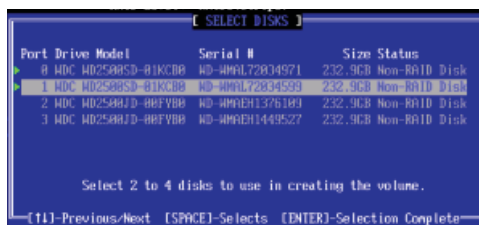

5. Use the <Up Arrow> <Down Arrow> keys to highlight a drive and press <Space> to select it. A triangle appears to confirm the selection of the drive.
6. Use the <Up Arrow> <Down Arrow> keys to select the stripe size, ranging from 4 KB to 128 KB for the RAID 5 array, and hit <Enter>. **Note:** For a server, please use a lower stripe size, and for a multimedia system, use a higher stripe size. The default stripe size is 128 KB.
7. Enter your desired RAID volume capacity and press <Enter> when the capacity item is highlighted. The default setting is the maximum capacity allowed.

8. Press Enter when the Create Volume item is highlighted. A warning message displays.
9. When asked "Are you sure you want to create this volume (Y/N), press <Y> to create the RAID volume or <N> to go back to the Create Volume menu.

### ***Deleting a RAID Volume***



**Warning:** Be sure to back up your data before deleting a RAID set. You will lose all data on the disk drives when deleting a RAID set.

1. From the main menu, select "Delete RAID Volume" and press <Enter>.
2. Use the <Up Arrow> <Down Arrow> keys to select the RAID set you want to delete and press <Del>. A Warning message displays.
3. When asked "Are you sure you want to delete this volume (Y/N)?", press <Y> to delete the RAID volume or <N> to go back to the Delete Volume menu.

**Resetting to Non-RAID and Resetting a RAID HDD**

**Warning:** Use caution when you reset a RAID volume to non-RAID or when resetting a RAID volume. Resetting a RAID volume HDD or resetting a RAID HDD will reformat the HDD and delete the internal RAID structure on the drive.

1. From the main menu, select "Reset Disks to Non- RAID" and press <Enter>. The following screen will appear:



2. Use the <Up Arrow> <Down Arrow> keys to highlight the RAID set drive to reset and press <Space> to select.
3. Press <Enter> to reset the RAID set drive. A Warning message displays.
4. Press <Y> to reset the drive or <N> to go back to the main menu.

**Exiting the Intel Matrix Storage Manager Utility**

1. From the main menu, select "Exit" and press <Enter>. A warning message will appear.
2. Press <Y> to reset the drive or <N> to go back to the main menu.

## C-2 Installing Windows XP/2000/2003 for RAID Systems

### *Installing a New Operating System*

1. Insert the Microsoft the Windows XP/2000/2003 Setup CD in the DVD/CD drive, and the system will start booting up from the CD.
2. Press the <F6> key when the message "Press F6 if you need to install a third party SCSI or RAID driver" displays.
3. When the Windows XP/2000/2003 Setup screen appears, press "S" to specify additional device(s).
4. Insert the "Intel AA RAID XP/2000/2003 Driver for ESB2" driver diskette into the floppy drive and press <Enter>.
5. Choose the Intel® ESB2 SATA RAID controller from the list indicated in the XP/2000/2003 Setup Screen, and press the <Enter> key.
6. Press the <Enter> key to continue the installation process. (If you need to specify any additional devices to be installed, do so at this time.) Once all devices are specified, press the <Enter> key to continue with the installation.
7. From the Windows XP/2000/2003 Setup screen, press the <Enter> key. The XP/2000/2003 Setup will automatically load all device files and then continue the Windows XP/2000/2003 installation.
8. After the Windows XP/2000/2003 OS installation is completed, the system will automatically reboot.

**Note:** the current version of the ESB2 SATA RAID Utility can only support the Windows XP/2000/2003 Operating System.

# Appendix D

## System Specifications

### Processors

Four Intel® Xeon® 7300/7200 Series processors.

**Note:** Please refer to our web site for a complete listing of supported processors.

### Chipset

Intel 7300

### BIOS

8 Mb AMIBIOS® Flash ROM

### Memory Capacity

Twenty-four 240-pin DIMM sockets supporting up to 192 GB of FBD ECC DDR2-667/533 SDRAM

**Note:** See the memory section in Chapter 5 for details.

### SAS Controller

Onboard LSI-1068E controller for SAS drives (RAID 0, 1 and 10 support)  
RAID 5 is supported with the use of an optional iButton (AOC-ibutton68)

### Drive Bays

Six (6) hot-swap drive bays to house six (6) standard SAS drives

### Peripheral Drives/Bays

One (1) slim DVD-ROM drive

### Expansion Slots

Supports the use of the following low-profile expansion cards: one PCI-E x8 (in a x16 slot), one PCI-E x8, one PCI-E x4 (in a x8 slot) and one PCI-X133

### Serverboard

X7QC3 (proprietary ATX form factor)

Dimensions: 16" x 14.3" (406 x 363 mm)

### **Chassis**

SC828TQ-R1200LP (2U rackmount)

Dimensions (both): (WxHxD) 17.2 x 3.5 x 27.75 in. (473 x 89 x 705 mm)

### **Weight**

Gross (Bare Bone): 65.5 lbs. (29.8 kg.)

### **System Cooling**

Six heavy-duty 8-cm cooling fans (fan speed controlled by BIOS setting)

### **System Input Requirements**

AC Input Voltage: 100-240 VAC

Rated Input Current: 6A (115V) to 15A (240V)

Rated Input Frequency: 50-60 Hz

### **Power Supply**

Rated Output Power: 1200W w/PFC (Part# PWS-1K22-1R)

Rated Output Voltages: +3.3V (20A), +5V (20A), +12V (100A), -12V (0.6A), +5Vsb (4A)

Power Supply Efficiency Rating: 91% (peak)

### **Operating Environment**

Operating Temperature: 10° to 35° C (50° to 95° F)

Non-Operating Temperature: -40° to 70° C (-40° to 158° F)

Operating Relative Humidity: 8% to 90% (non-condensing)

Non-Operating Relative Humidity: 5 to 95% (non-condensing)

### **Regulatory Compliance**

Electromagnetic Emissions:

FCC Class A, EN 55022 Class A, EN 61000-3-2/-3-3, CISPR 22 Class A

Electromagnetic Immunity:

EN 55024/CISPR 24, (EN 61000-4-2, EN 61000-4-3, EN 61000-4-4, EN 61000-4-5, EN 61000-4-6, EN 61000-4-8, EN 61000-4-11)

Safety:

EN 60950/IEC 60950-Compliant

UL Listed (USA)

CUL Listed (Canada)

TUV Certified (Germany)

CE Marking (Europe)

California Best Management Practices Regulations for Perchlorate Materials:  
This Perchlorate warning applies only to products containing CR (Manganese Dioxide) Lithium coin cells. "Perchlorate Material-special handling may apply. See [www.dtsc.ca.gov/hazardouswaste/perchlorate](http://www.dtsc.ca.gov/hazardouswaste/perchlorate)"

(continued from front)

The products sold by Supermicro are not intended for and will not be used in life support systems, medical equipment, nuclear facilities or systems, aircraft, aircraft devices, aircraft/emergency communication devices or other critical systems whose failure to perform be reasonably expected to result in significant injury or loss of life or catastrophic property damage. Accordingly, Supermicro disclaims any and all liability, and should buyer use or sell such products for use in such ultra-hazardous applications, it does so entirely at its own risk. Furthermore, buyer agrees to fully indemnify, defend and hold Supermicro harmless for and against any and all claims, demands, actions, litigation, and proceedings of any kind arising out of or related to such ultra-hazardous use or sale.