

# SUPERMICR<sup>®</sup> SuperBlade MBI-6119M-T2N Blade Module Quick Reference Guide

## Board Layout

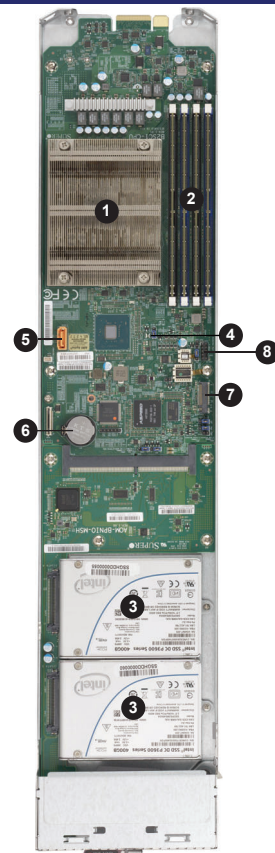

MBI-6119M-T2N

MBI-6119M-T2N Module Layout

Item	Description
1	Intel Xeon Processor E-2100 series processors embedded in a H4 (LGA 1151) socket
2	DIMM slots for DIMM memory modules
3	2.5" SATA3/NVMe/SSD/HDD's
4	CMOS Clear
5	SATA DOM Ports
6	Battery
7	M.2 PCI-E SATA connector
8	TMP connector

## Caution

**SAFETY INFORMATION**  
**IMPORTANT:** See installation instructions and safety warning before connecting system to power supply.  
[http://www.supermicro.com/about/policies/safety\\_information.cfm](http://www.supermicro.com/about/policies/safety_information.cfm)

**WARNING:**  
 To reduce risk of electric shock/damage to equipment, disconnect power from server by disconnecting all power cords from electrical outlets. If any CPU socket empty, install protective plastic CPU cap

**WARNING:**  
 Always be sure all power supplies for this system have the same power output. If mixed power supplies are installed, the system will not operate.

For more information go to: <http://www.supermicro.com/support>

## Memory Support

The MBI-6119M-T2N MicroBlade module has four (4) 288-pin DIMM sockets that can support up to 12 GB of DDR4 2666 MHz speed, 16 GB size, 1.2 V voltage 2RX8 ECC VLP UDIMM memory. Memory is interleaved, which requires modules to be of the same size and speed.

Please refer to the Supermicro web site for a list of supported memory <http://www.supermicro.com/products/microblade>. The detailed specifications for a blade module will contain a link to a list of recommended memory sizes and manufacturers.

**Note:** For optimized memory bandwidth it is strongly recommended that ALL memory slots in this MicroBlade module be populated by DIMMs.

**Warning:** Though multiple DIMM memory module types and speeds may be supported, you need to use DIMM memory modules of the same speed and type.

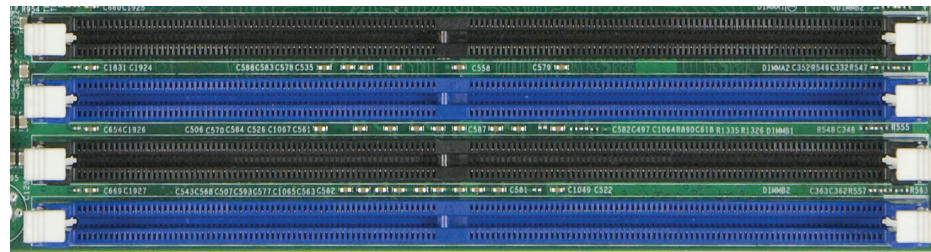

## Control Panel

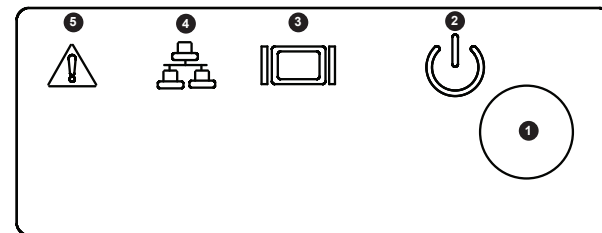

Blade Control Panel			
Item	Function	State	Description
1	Power Button	N/A	Turns blade module on and off
		Green	Indicates power status "On"
		Solid Orange	Indicates power status "Off" (with power cables plugged in)
2	Power LED	Flashing Orange	Flashing Orange: Indicates node is not ready or not enough power to turn on
		Flashing Blue	Indicates KVM being utilized on blade unit
3	KVM/UID LED	Flashing Blue	Indicates UID activated on blade module
		Flashing Green	Indicates network activity over LAN
4	Network/IB LED	Flashing Orange	Indicates network activity
		Red	Indicates a memory error, overheat, VGA error or any error that prevents booting

## Enclosure Requirements

### Enclosure Requirements

The MBI-6119M-T2N/T3N blade module requires one of the following enclosures to run in:

MBE-628E-416	MBE-628E-622	MBE-628E-822	MBE-314E-416
MBE-628E-420	MBE-628E-816	MBE-628E-422	MBE-314E-420
MBE-628E-420D	MBE-628E-820	MBE-314E-220	MBE-314E-420D
MBE-628E-422	MBE-628E-820D	MBE-314E-220D	

See the Supermicro website for details on Microblade enclosures at: <https://www.supermicro.com/en/products/microblade>

**Note:** The MBI-6119M-T2N blade module also requires one or more power supplies in the enclosure to run the blade module. Available power supplies can be found on the Supermicro website at <https://www.supermicro.com/products/SuperBlade/powersupply/>.



## CPU and Heat Sink Installation

### Installing the Processor

1. Begin by removing power from the system.
2. Remove the cover plate that protects the CPU#1 socket. Lift the lever on the socket until it points straight up. With the lever raised, lift open the processor retention plate.

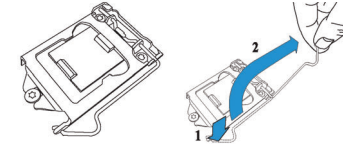

3. Gently lift the load lever to open the load plate. Remove the plastic cover plate.

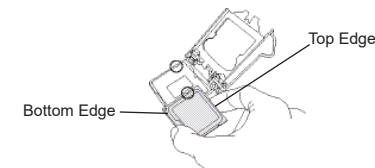

4. Use your thumb and your index finger to hold the edges of the processor. Align the CPU key (the semi-circle cutouts) with the socket keys.

### Installing a Passive CPU Heatsink

An active type heatsink is used on the motherboard.

**Note:** You should apply thermal grease to the heatsink if it has not already been pre-applied.

1. Place the heatsink on top of the CPU so that the four mounting holes are aligned with those on the heatsink retention mechanism.
2. Screw in two diagonal screws (i.e. the #1 and the #2 screws) until they are just snug. Do not fully tighten the screws or you may damage the CPU.
3. Add the two remaining screws then finish the installation by fully tightening all four screws (be careful not to overtighten).

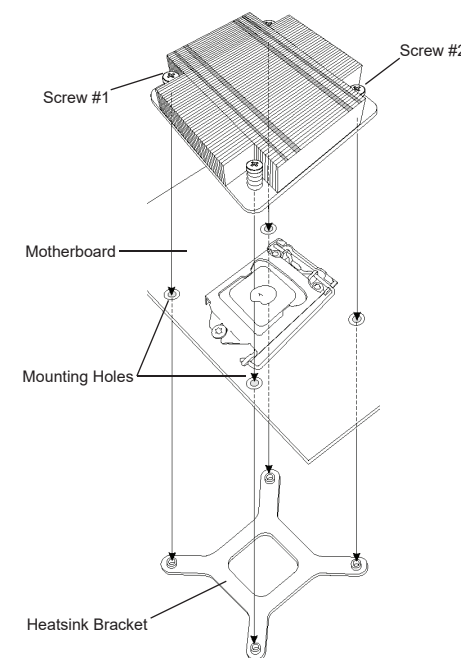

5. Once aligned, carefully place the processor into the socket. Do not drop the processor on the socket, move or rub the processor against the socket or against any socket pins, which may damage the components.

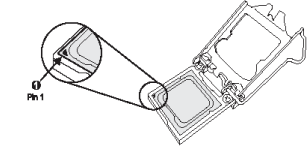

6. With the processor inserted into the socket, inspect the four corners of the CPU to make sure that it is properly installed and flush with the socket.

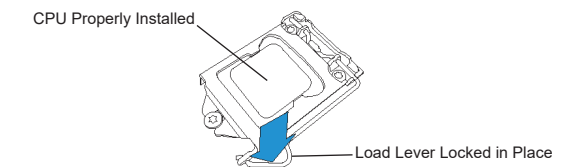

7. Carefully press the processor load lever down until it locks into its retention tab.

### Removing the CPU and the Heatsink

We do not recommend removing the heatsink. If necessary, please follow the instructions below to prevent damage to the CPU or the CPU socket.

1. Unscrew and remove the heatsink screws from the motherboard in the sequence as shown in the figure above.
2. Hold and gently pivot the heatsink back and forth to loosen it from the CPU. (Do not use excessive force when dislodging the heatsink.)
3. Once the heatsink is loose, remove it from the CPU.
4. Clean the surface of the CPU and the heatsink to get rid of the old thermal grease. Reapply the proper amount of thermal grease to the surface before you re-install the heatsink.

