

CONTACT INFORMATION

- www.supermicro.com (Email: support@supermicro.com)
- Manuals: http://www.supermicro.com/support/manuals
- Drivers & Utilities: ftp://ftp.supermicro.com
- Safety: http://www.supermicro.com/about/policies/safety_information.cfm

PACKAGE CONTENTS (Applies to individual-pack only)

- One (1) Supermicro Motherboard
- Six (6) SATA Cables
- One (1) Floppy Drive Ribbon Cable
- One (1) IDE Cable
- One (1) I/O Shield
- One (1) Quick Reference Guide

Motherboard Layout and Features

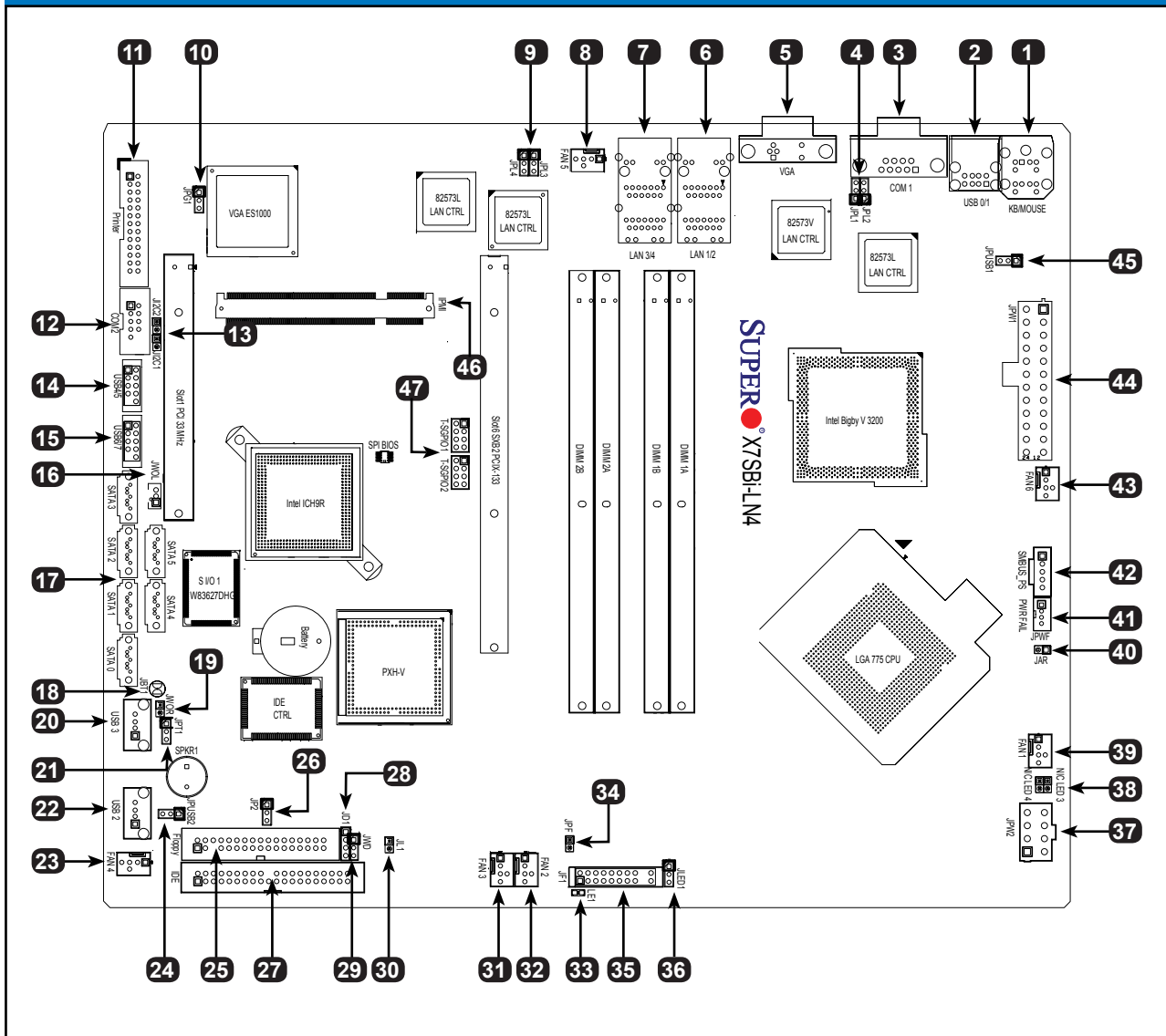

Jumpers, Connectors and LED Indicators

Jumpers			
Item #	Jumper	Description	Default
4, 9	JPL1/JPL2, JPL3/JPL4	GLAN 1, 2, 3, 4 Enable	Pins 1-2 (Enabled)
10	JPG1	VGA Enable/Disable	Pins 1-2 (Enabled)
13	J1C1, J1C2	SMB to PCI Slots	Open/Open (Disabled)
18	JBT1	CMOS Clear	See Chapter 2 in User Manual
21	JPT1 (X7SBI-LN4-TM)	TPM Support Enable	Pins 1-2 (Enabled)
24, 45	JUSB2, JUSB1	USB 0-1/USB 2-7 Enable	JUSB1:Pins 1-2 (Enabled), JUSB2:Pins 2-3 (Disabled)
26	JP2	IDE Enable/Disable	Pins 1-2 (Enabled)
29	JWD	Watch Dog Timer Enable	Pins 1-2 (Reset)
34	JPF	Power Force On	Open (Disabled)
40	JAR	Power Alarm Reset	Open (Normal)

Connectors		
Item #	Connector	Description
1	KB/Mouse	PS/2 Keyboard/Mouse
2	USB 0-1	Back Panel Universal Serial Bus Ports
3, 12	COM1, COM2	COM Port/Serial Port 1-2 Connectors
5	VGA	Video Graphics Port
6, 7	LAN1, LAN2, LAN3, LAN4	Ethernet RJ45 (Gigabit LAN) Connectors
8, 23, 43	Fan 5, Fan 4, Fan 6	Fan 1 & 2: System Fan Headers, Fan 6: CPU Fan
11	Printer	Parallel Printer Port
14, 15, 20, 22	USB 4/5, 6/7, 3, 2	FP (Onboard) USB Ports and FP Accessible USB Headers
16	JWOL	Wake-on-LAN Header
17	SATA 0-5	SATA Headers
19	JWOR	Wake-on-Ring Header
25	Floppy	Floppy Disk Connector
27	IDE	IDE Hard Drive Connector (Blue)
28	JD1	External Speaker Header
30	JL1	Chassis Intrusion Header
31, 32, 39,	Fan 3, Fan 2, Fan 1	System Fan Header (Fan 1: CPU Fan)
35	JF1	FP Control Panel Header
36	JLED1	Onboard Power LED Header
37	JPW2	12V 8-pin Power Connector (Required)
41	PWR Fail	Power Fail
42	SMBUS_PS	Power SMBus (I ² C)
44	JPW1	ATX 24-pin Power Connector (Required)
46	IPMI	SIMSO IPMI 2.0 Socket
47	T-SGPIO 1/2	Serial General Purpose Input Output Ports

LED Indicators				
Item #	LED	Description	Color/State	Status
33	LE1	Onboard Stby PWR LED	Green: Solid on	Power On
38	NIC LED3, NIC LED4	LED for GLAN Port 3 and 4	Blinking	Network Activity

Memory Support

This motherboard supports up to 8 GB of Unbuffered (UDIMM) DDR2 ECC/Non-ECC 800/677 MHz memory in 4 memory slots.

Note: For memory optimization, use only DIMM modules that have been validated by Supermicro. For the latest memory updates, please refer to our website at <http://www.supermicro.com/products/motherboard>.

DIMM Installation

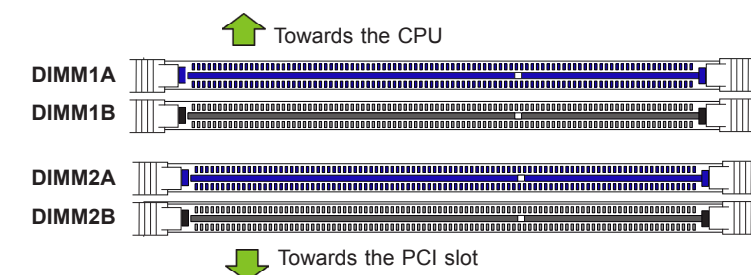

Possible System Memory Allocation & Availability		
System Device	Size	Physical Memory Remaining (-Available) (4 GB Total System Memory)
Firmware Hub flash memory (System BIOS)	1 MB	3.99 GB
Local APIC	4 KB	3.99 GB
Area Reserved for the chipset	2 MB	3.99 GB
I/O APIC (4 Kbytes)	4 KB	3.99 GB
PCI Enumeration Area 1	256 MB	3.76 GB
PCI Express (256 MB)	256 MB	3.51 GB
PCI Enumeration Area 2 (if needed) -Aligned on 256-MB boundary-	512 MB	3.01 GB
VGA Memory	16 MB	2.85 GB
TSEG	1 MB	2.84 GB
Memory available for the OS & other applications		2.84 GB

- Notes:**
1. Due to OS limitations, some operating systems may not show more than 4GB of memory.
 2. Both Unbuffered ECC and Non-ECC memory modules can be installed in the memory slots. When ECC memory is used, it may take 25-40 seconds for the VGA to display.

Back Panel IO Connectors

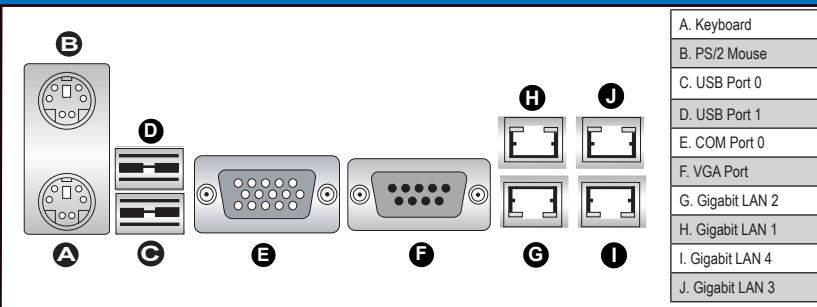

CPU Installation

1. Open socket cover
2. Insert CPU (Align Notches)
3. Close and secure lever.

Heatsink Installation

1. Apply thermal grease
2. Set heatsink on CPU
3. Twist to lock fasteners

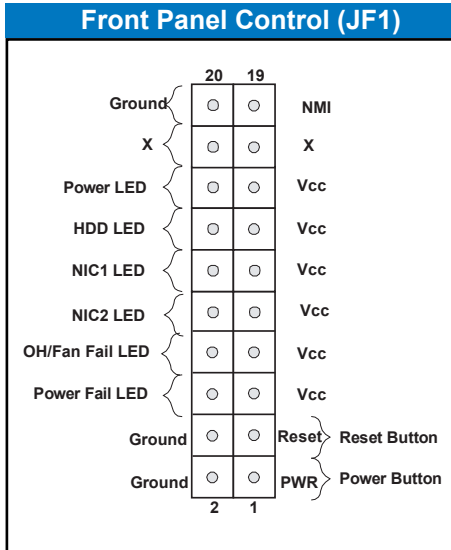

Note: Graphics shown in this quick reference guide are for illustration only. Your components may or may not look exactly the same as drawings shown in this guide.

Note: Refer to Chapter 2 of the User Manual for detailed information on jumpers, connectors, and LED indicators.

Note: Refer to Chapter 2 of the User Manual for detailed information on memory support and CPU/motherboard installation instructions.