

Motherboard Layout and Features

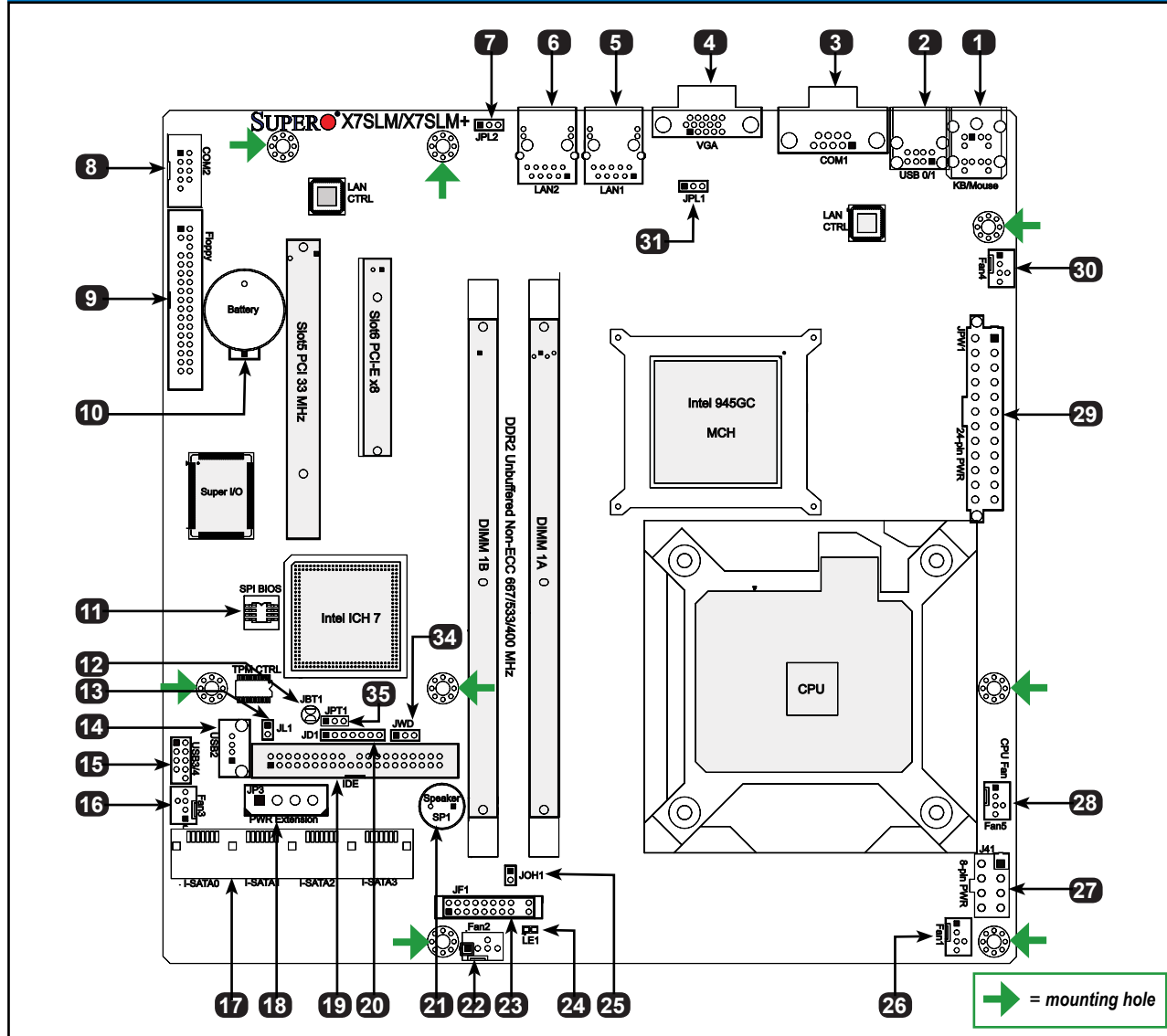

Jumpers, Connectors and LED Indicators

Jumpers			
Item #	Jumper	Description	Default
12	JBT1	CMOS Clear	See Chapter 2 in User Manual
7, 31	JPL2, JPL1	GLAN 2 and GLAN 1 Enable	Pins 1-2 (Enabled)
34	JWD	Watch Dog Timer Enable	Pins 1-2 (Reset)
35	JPT1	TPM Support Enable (X7SLM+ only)	Pins 1-2 (Enabled)

Connectors		
Item #	Connector	Description
1	KB/Mouse	PS/2 Keyboard and Mouse
2	USB 0/1	Back Panel Universal Serial Bus Ports
3, 8	COM1, COM2	COM Port 1, COM 2 Header
4	VGA	Video Graphics Port
5, 6	LAN1, LAN2	Ethernet RJ45 (Gigabit LAN) Connectors 1 and 2
9	Floppy	Floppy Disk Connector
10	Battery	Onboard Battery
11	SPI BIOS	SPI BIOS Chip
13	JL1	Chassis Intrusion Header
14	USB 2	Internal USB Port
15	USB 3/4	Front Panel USB Connections
17	I-SATA 0~3	SATA Headers
18	PWR EXTENSION (JP3)	Power Extension Connector for Add-on card
19	IDE	IDE Hard Drive Connector
20	JD1	Power LED/External Speaker Header
21	SP1	Internal Speaker/Buzzer
16, 22, 26, 28, 30	Fans 3, 2, 1, 5, 4	System Cooling Fans 1~4 & CPU Fan (Fan5)
23	JF1	FP Control Panel Header
25	JOH1	Overheat LED Header
27	8-Pin PWR (J41)	12V 8-pin Power Connector (Required)
29	24-Pin PWR (JPW1)	ATX 24-pin Power Connector (Required)

LED Indicators				
Item #	LED	Description	Color/State	Status
24	LE1	Power LED	Green: On	System On

Memory Support

This motherboard supports up to 2 GB of Unbuffered (UDIMM) Non-ECC DDR2 400/533/667 MHz memory in 2 memory slots.

Note: For memory optimization, use only DIMM modules that have been validated by Supermicro. For the latest memory updates, please refer to our website at <http://www.supermicro.com/products/motherboard>.

DIMM Installation

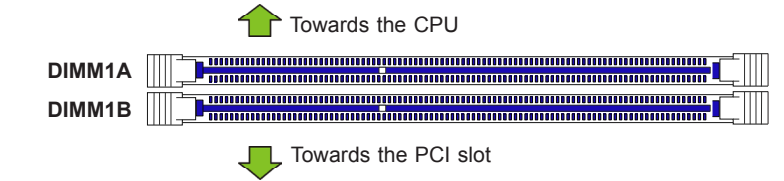

Installing DDR2 Memory

1. Insert the desired number of DIMMs into the memory slots, starting with DIMM1A. Insert each DIMM module vertically into its slot. Pay attention to the notch along the bottom of the module to prevent incorrect DIMM module installation.
2. Gently press down on the DIMM module until it snaps into place in the slot. Repeat step 1 to install DIMM1B if needed.

CPU Installation

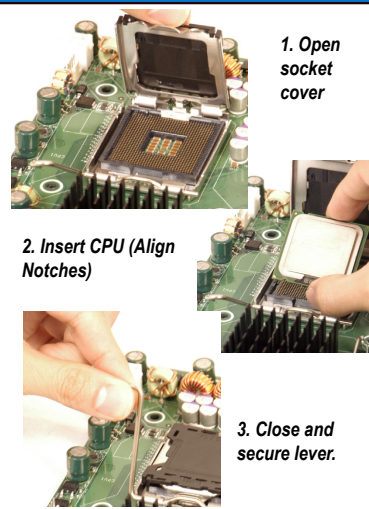

Heatsink Installation

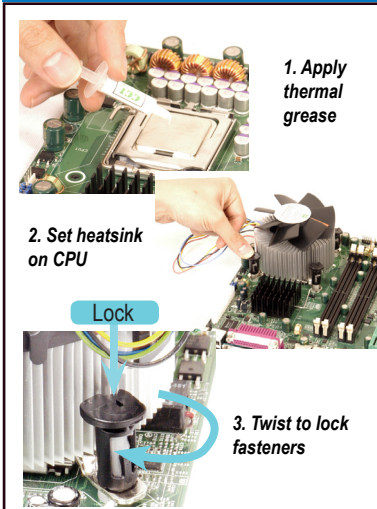

Front Panel Control (JF1)

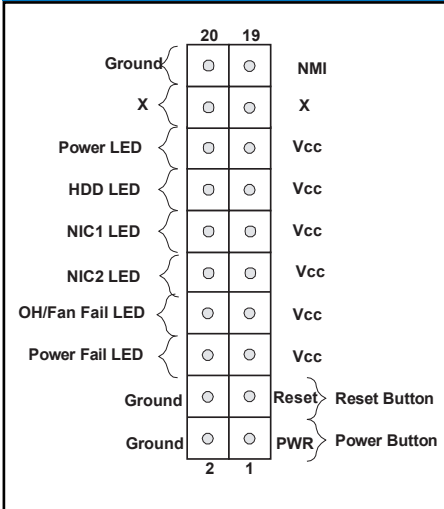

Back Panel IO Connectors

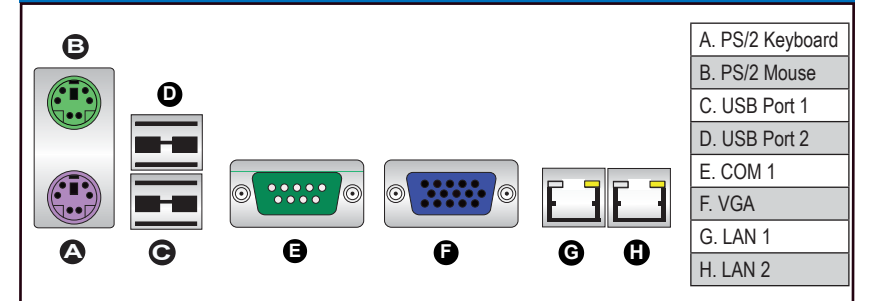

Note: Graphics shown in this quick reference guide are for illustration only. Your components may or may not look exactly the same as drawings shown in this guide.

Note: Refer to Chapter 2 of the User Manual for detailed information on jumpers, connectors, and LED indicators.

Note: Refer to Chapter 2 of the User Manual for detailed information on memory support and CPU/motherboard installation instructions.