

CONTACT INFORMATION

- Website: www.supernmicro.com
- General Information: marketing@supernmicro.com
- Tech Support: support@supernmicro.com
- Phone: +1 (408) 503-8000, Fax: +1 (408) 503-8008

FOR YOUR SYSTEM TO WORK PROPERLY, PLEASE DOWNLOAD APPROPRIATE DRIVERS/IMAGES/USER'S MANUAL FROM THE LINKS BELOW:

- www.supernmicro.com (Email: support@supernmicro.com)
- Manuals: <http://www.supernmicro.com/support/manuals>
- Drivers & Utilities: <http://www.supernmicro.com/wftp>
- Safety: http://www.supernmicro.com/about/policies/safety_information.cfm

PACKAGE CONTENTS (FOR SINGLE-PACK ONLY)

- One (1) Supermicro Motherboard
- Two (2) SATA Cables (X9DRD-7LN4F(-JBOD))
- Six (6) SATA Cables (X9DRD-EF)
- Two (2) I-Pass to 4 SATA (50-cm) Cables
- One (1) I/O Shield



WARNING: This product can expose you to chemicals including lead, known to the State of California to cause cancer and birth defects or other reproductive harm. For more information, go to www.P65Warnings.ca.gov.

Motherboard Layout and Features

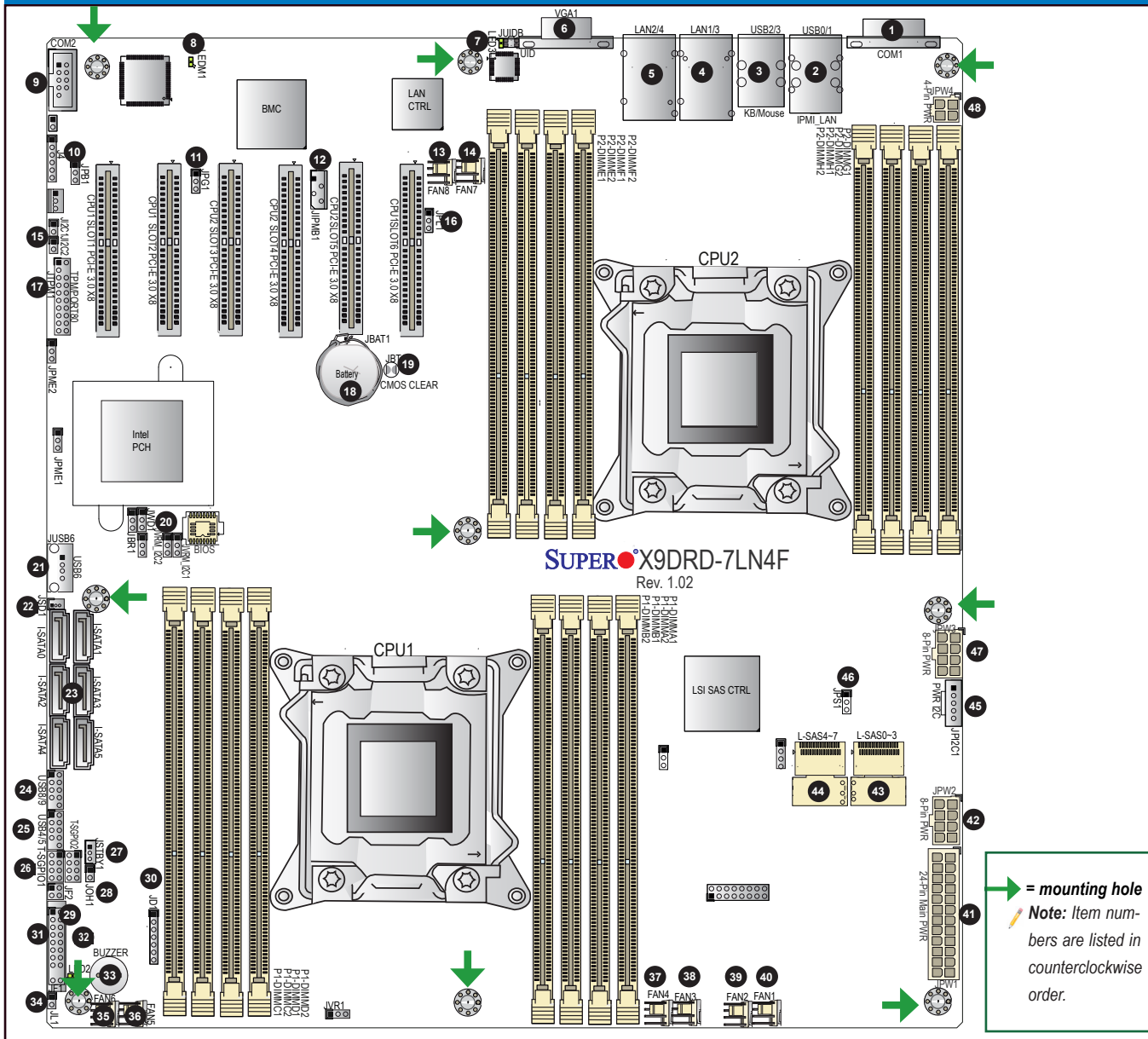

Jumpers/Connectors/LED Indicators

Jumpers

Jumper	Item#	Description	Default Setting
JBT1	19	Clear CMOS	See Chpt. 2 in User Manual
J1 ² C1/J1 ² C2	15	SMB to PCI-E Slots	Off (Disabled)
JPB1	10	BMC Enabled	Pins 1-2 (Enabled)
JPG1	11	VGA Enabled	Pins 1-2 (Enabled)
JPL1	16	GLAN1/GLAN2 Enable	Pins 1-2 (Enabled)
JPS1 (X9DRD-7LN4F (-JBOD) Only)	46	SAS Enabled	Pins 1-2 (Enabled)
JWD1	20	Watch Dog Timer Enable	Pins 1-2 (Reset)

Connectors

Connector	Item#	Description
COM1/COM2	1, 9	Backplane COM Port1/Front Accessible COM2 Header
FAN1-8	40, 39, 38, 37, 36, 35, 14, 13	CPU/System Fan Headers
JBAT1	18	Onboard Battery (See Chpt. 3 for Used Battery Disposal)
JD1	30	Speaker/Power LED Indicator
JF1	31	Front Panel Control Header
JF2	29	LAN3 (NIC3)/LAN4 (NIC4) LED Indicators
JIPMB1	12	4-pin External BMC I ² C Header (for an IPMI Card)
JL1	34	Chassis Intrusion
JOH1	28	Overheat LED Indicator
JPI ² C1	45	Power Supply SMBbus I ² C Header
JPW1	41	24-Pin ATX Main Power Connector
JPW2/3	42, 47	12V 8-Pin Power Connectors
JPW4	48	12V 4-Pin Power Connectors
JSD1	22	SATA DOM (Device on Module) Power Connector
JSTBY1	27	+5V Standby Power Header
JTPM1	17	TPM (Trusted Platform Module)/Port 80
LAN1/3, LAN2/4	4, 5	Gigabit LAN Ports 1/2, 3/4 (LAN3/4 for -7LN4F(-JBOD))
(IPMI) LAN	2	IPMI_Dedicated LAN
(I)SATA1-6	23	Intel SATA Connectors 1-6 from the Intel PCH
(L)SAS0-3, 4-7	43, 44	Serial_Link SCSI Attached 2.0 Connectors 0-3, 4-7 from the LSI SAS 2308 Controller (LAN3/4 for -7LN4F(-JBOD))
SP1	33	Onboard Buzzer (Internal Speaker)
(T)-SGPIO 1/2	26	Serial ATA (SATA) General Purpose I/O Header
UID	7	UID (Unit Identification) Switch
USB 0/1, 2/3	2, 3	Back Panel USB 0/1, 2/3
USB 4/5, 8/9	25, 24	Front Panel Accessible USB Connections (4/5, 8/9)
USB 6	21	Type A USB Embedded Drive Connector
VGA1	6	Backpanel VGA Port

LED Indicators

LED	Item	Description	State	Status
LED2	32	Standby PWR LED	Green: On	Standby PWR On
LED3	7	Rear UID LED	Blue: On	Unit Identified
LEDM1	8	BMC Heartbeat LED	Green: Blinking	BMC Normal

Memory Support

This motherboard supports up to 512 GB of 240-pin Registered (RDIMM)/Load Reduced (LRDIMM) ECC or 128 GB of Unbuffered (UDIMM) ECC/Non-ECC DDR3 800/1066/1333/1600 MHz 4-channel (per CPU) memory in 16 DIMM slots.

Note: For memory optimization, use only DIMM modules that have been validated by Supermicro. For the latest memory updates, please refer to our website at <http://www.supernmicro.com/products/motherboard>.

DIMM Installation

Insert the desired number of DIMMs into the memory slots, starting with P1-DIMMA1. For memory to work properly, follow the tables below for memory population order. Refer to the motherboard layout (at left) for the location of the DIMM slots.

Processors and their Corresponding Memory Modules

CPU#	Corresponding DIMM Modules							
CPU 1	P1-DIMMA1	P1-DIMMB1	P1-DIMMC1	P1-DIMMD1	P1-DIMMA2	P1-DIMMB2	P1-DIMMC2	P1-DIMMD2
CPU 2	P2-DIMME1	P2-DIMMF1	P2-DIMMG1	P2-DIMMH1	P2-DIMME2	P2-DIMMF2	P2-DIMMG2	P2-DIMMH2

Processor and Memory Module Population for Optimal Performance

Number of CPUs+DIMMs	CPU and Memory Population Configuration Table (For memory to work properly, please follow the instructions below.)
1 CPU & 2 DIMMs	CPU1 P1-DIMMA1/P1-DIMMB1
1 CPU & 4 DIMMs	CPU1 P1-DIMMA1/P1-DIMMB1, P1-DIMMC1/P1-DIMMD1
1 CPU & 5-8 DIMMs	CPU1 P1-DIMMA1/P1-DIMMB1, P1-DIMMC1/P1-DIMMD1 + Any memory pairs in P1-DIMMA2/P1-DIMMB2/P1-DIMMC2/P1-DIMMD2 slots
2 CPUs & 4 DIMMs	CPU1 + CPU2 P1-DIMMA1/P1-DIMMB1, P2-DIMME1/P2-DIMMF1
2 CPUs & 6 DIMMs	CPU1 + CPU2 P1-DIMMA1/P1-DIMMB1/P1-DIMMC1/P1-DIMMD1, P2-DIMME1/P2-DIMMF1
2 CPUs & 8 DIMMs	CPU1 + CPU2 P1-DIMMA1/P1-DIMMB1/P1-DIMMC1/P1-DIMMD1, P2-DIMME1/P2-DIMMF1/P2-DIMMG1/P2-DIMMH1
2 CPUs & 10-16 DIMMs	CPU1/CPU2 P1-DIMMA1/P1-DIMMB1/P1-DIMMC1/P1-DIMMD1, P2-DIMME1/P2-DIMMF1/P2-DIMMG1/P2-DIMMH1 + Any memory pairs in P1, P2 DIMM slots
2 CPUs & 16 DIMMs	CPU1/CPU2 P1-DIMMA1/P1-DIMMB1/P1-DIMMC1/P1-DIMMD1, P2-DIMME1/P2-DIMMF1/P2-DIMMG1/P2-DIMMH1, P1-DIMMA2/P1-DIMMB2/P1-DIMMC2/P1-DIMMD2, P2-DIMME2/P2-DIMMF2/P2-DIMMG2/P2-DIMMH2

Back Panel IO Connectors

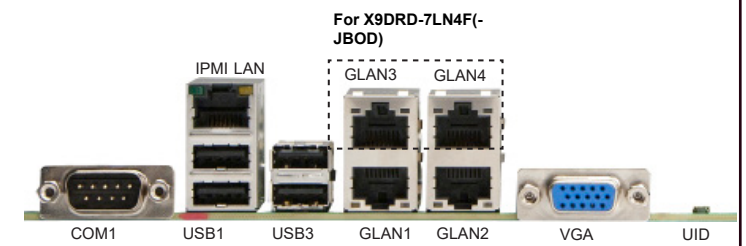

Note 1: GLAN3/GLAN4 and SAS connections are available on the X9DRD-7LN4F(-JBOD).
Note 2: Refer to Chapter 2 of the user's manual for detailed information on memory support and CPU/motherboard installation instructions.

CPU Installation

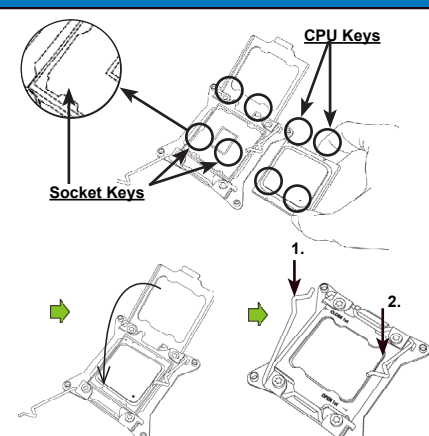

Heatsink Installation

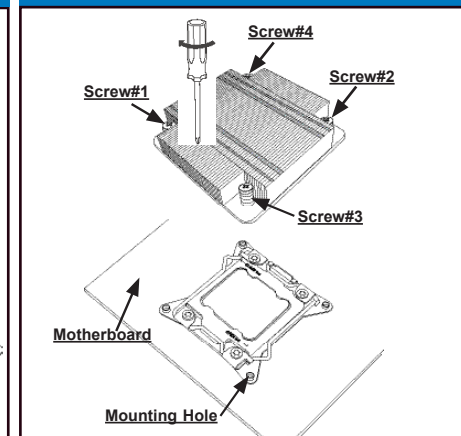

Front Panel Control (JF1)

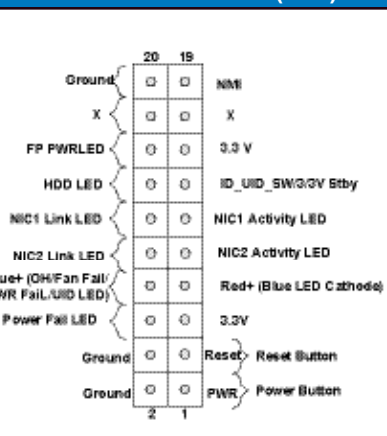

Note: Graphics shown in this quick guide are for illustration only. Your components may or may not look exactly the same as drawings shown in this guide.

Note: Refer to Chapter 2 of the User Manual for detailed information on jumpers, connectors, and LED indicators.