

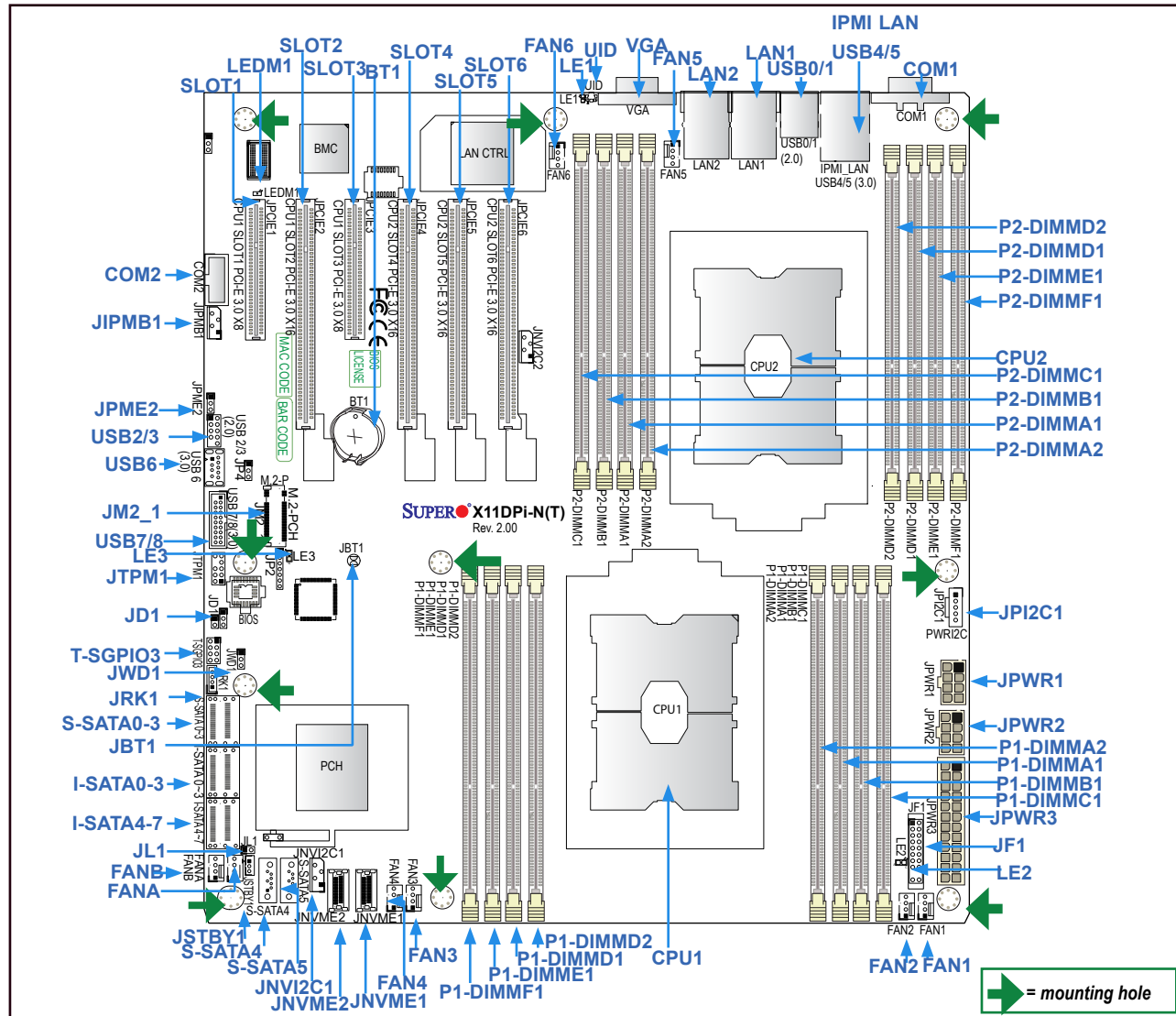

**Motherboard Layout and Features**

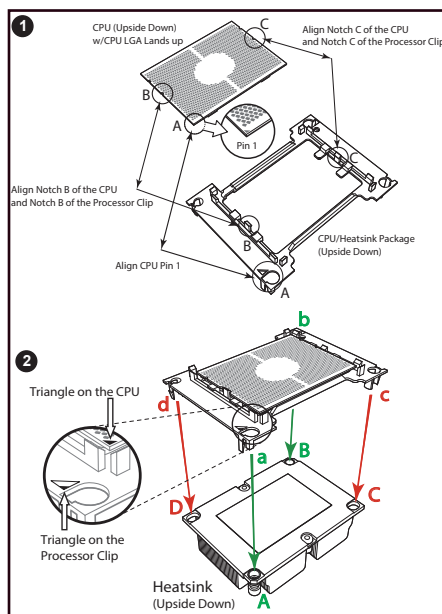

**CPU/Heatsink Installation**



**Installing Processor/Heatsink Module**

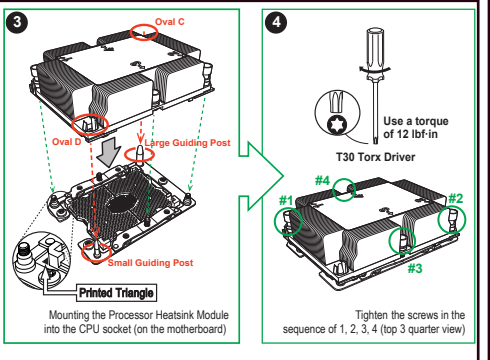

**Notes:** 1. Please refer to Chapter 2 of the user's manual for detailed instructions of CPU/Heatsink and memory installation. 2. 10GbE LAN ports are for X11DPi-NT only. 3. Please refer to our website at [www.supermicro.com](http://www.supermicro.com) for CPU/Memory support updates. 4. All graphics shown in this quick reference guide are for illustration only. Your components may or may not look the same as the graphics shown in this quick reference guide.

**Front Control Panel (JF1)**

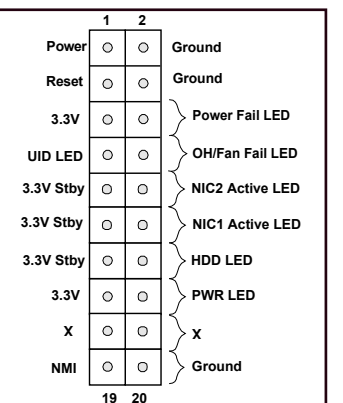

**Jumpers and Connectors**

Jumper	Description	Default Setting
JBT1	CMOS Clear	Open (Normal)
JPME2	Manufacturing Mode Select	Pins 1-2 (Normal)
JWD1	Watch Dog Timer Enable	Pins 1-2 (Reset to System)

Connector	Description
BT1	Onboard CMOS battery socket
COM1/COM2	Back panel COM port/COM header for front access
FAN1-6, FANA/FANB	System cooling fan headers (FAN1-FAN6, FAN A, FAN B)
IPMI_LAN	Dedicated IPMI_LAN port
I-SATA0~3, I-SATA4~7	SATA 3.0 connection header supported by the Intel PCH
JD1	Speaker/buzzer header (used in conjunction with an external speaker/buzzer) (optional)
JF1	Front Panel Control header
JIPMB1	4-pin BMC External I <sup>2</sup> C header (for an IPMI-supported card)
JL1	Chassis intrusion header ( <b>Note:</b> Please connect a cable from the Chassis Intrusion header at JL1 to the chassis to receive an alert via IPMI.)
JM2_1	PCI-E M.2 slot
JNVI <sup>2</sup> C1	NVMe I <sup>2</sup> C header
JNVME1/JNVME2	NVMe Slot1/NVMe Slot2
JPI <sup>2</sup> C1	Power Supply SMBbus I <sup>2</sup> C header
JPWR1/JPWR2	8-pin Power Supply connectors
JPWR3	24-pin ATX main power supply connector
JRK1	Intel VROC RAID Key for NVMe SSD
JSTBY1	Standby power header
JTPM1	Port 80 connector for Trusted Platform Module (TPM)
LAN1/LAN2	Gigabit LAN/10G LAN Ethernet ports on the backpanel
S-SATA0-3	S-SATA 3.0 connection header
S-SATA4/S-SATA5	Powered S-SATA Ports SuperDOM (Disk On Module) devices
SLOT1/SLOT3	PCI-Express 3.0 X8 Slots supported by CPU1
SLOT2	PCI-Express 3.0 X16 Slot supported by CPU1
SLOT4/SLOT5/SLOT6	PCI-Express 3.0 X16 Slots supported by CPU2
T-SGPIO3	General Purpose Serial I/O port
UID	Unit Identifier (UID) switch
USB0/1 & USB4/5	Backpanel USB 2.0 ports (USB0/1) & USB 3.0 ports (USB4/5)
USB2/3	Front Accessible USB 2.0 header for USB 2/3
USB6	Type A USB 3.0 Header
USB7/8	Front Accessible USB 3.0 header for USB7/8
VGA	VGA Port

LED	Description	Status
LE1	UID (Unit Identifier) LED	BMC Heartbeat LED
LE2	Onboard Power LED	On: Onboard power on
LE3	PCI-E M.2 Activity LED	On: PCI-E M.2 active
LEDM1	BMC Heartbeat LED	Blinking Green: BMC normal

**CPU Support**

This motherboard supports dual Intel Xeon Scalable-SP or 2nd Gen Intel Xeon Scalable-SP series processors with support of UltraPath Interconnect (UPI) of up to 10.4 GT/s.

**Memory Support**

This motherboard supports up to 4TB of 3DS LRDIMM, LRDIMM, 3DS RDIMM, and RDIMM DDR4 (288-pin) ECC 2933/2666/2400/2133 MHz memory modules in 16 slots. (**Notes:** 1. Up to 5TB is supported with (L)RDIMM and DCPMM populated in a balanced memory configuration. 2. 2933 MHz memory is supported by 2nd Gen Intel Xeon Scalable-SP(82xx/62xx) series processors only. 3. Unbalanced memory configuration decreases memory performance and is not recommended.)

**Memory Population Table**  
**Memory Population Table for the X11DP Motherboard w/16 DIMM Slots Onboard**

When 1 CPU is used:	Memory Population Sequence
1 CPU & 1 DIMM	CPU1: P1-DIMMA1
1 CPU & 2 DIMMs	CPU1: P1-DIMMA1/P1-DIMMD1
1 CPU & 3 DIMMs	CPU1: P1-DIMMC1/P1-DIMMB1/P1-DIMMA1
1 CPU & 4 DIMMs	CPU1: P1-DIMMB1/P1-DIMMA1/P1-DIMMD1/P1-DIMME1
1 CPU & 5 DIMMs (Unbalanced: not recommended)	CPU1: P1-DIMMC1/P1-DIMMB1/P1-DIMMA1/P1-DIMMD1/P1-DIMME1
1 CPU & 6 DIMM	CPU1: P1-DIMMC1/P1-DIMMB1/P1-DIMMA1/P1-DIMMD1/P1-DIMME1/P1-DIMMF1
1 CPU & 7 DIMMs (Unbalanced: not recommended)	CPU1: P1-DIMMC1/P1-DIMMB1/P1-DIMMA1/P1-DIMMA2/P1-DIMMD1/P1-DIMME1/P1-DIMMF1
1 CPU & 8 DIMMs (Unbalanced: not recommended)	CPU1: P1-DIMMC1/P1-DIMMB1/P1-DIMMA1/P1-DIMMA2/P1-DIMMD2/P1-DIMMD1/P1-DIMME1/P1-DIMMF1

When 2 CPUs are used:	Memory Population Sequence
2 CPUs & 2 DIMMs	CPU1: P1-DIMMA1 CPU2: P2-DIMMA1
2 CPUs & 4 DIMMs	CPU1: P1-DIMMA1/P1-DIMMD1 CPU2: P2-DIMMA1/P2-DIMMD1
2 CPUs & 6 DIMMs	CPU1: P1-DIMMC1/P1-DIMMB1/P1-DIMMA1 CPU2: P2-DIMMC1/P2-DIMMB1/P2-DIMMA1
2 CPUs & 8 DIMMs	CPU1: P1-DIMMB1/P1-DIMMA1/P1-DIMMD1/P1-DIMME1 CPU2: P2-DIMMB1/P2-DIMMA1/P2-DIMMD1/P2-DIMME1
2 CPUs & 10 DIMMs	CPU1: P1-DIMMC1/P1-DIMMB1/P1-DIMMA1/P1-DIMMD1/P1-DIMME1/P1-DIMMF1 CPU2: P2-DIMMC1/P2-DIMMB1/P2-DIMMA1/P2-DIMMD1/P2-DIMME1/P2-DIMMF1
2 CPUs & 12 DIMMs	CPU1: P1-DIMMC1/P1-DIMMB1/P1-DIMMA1/P1-DIMMD1/P1-DIMME1/P1-DIMMF1 CPU2: P2-DIMMC1/P2-DIMMB1/P2-DIMMA1/P2-DIMMD1/P2-DIMME1/P2-DIMMF1
2 CPUs & 14 DIMMs (Unbalanced: not recommended)	CPU1: P1-DIMMC1/P1-DIMMB1/P1-DIMMA1/P1-DIMMA2/P1-DIMMD1/P1-DIMME1/P1-DIMMF1 CPU2: P2-DIMMC1/P2-DIMMB1/P2-DIMMA1/P2-DIMMA2/P2-DIMMD1/P2-DIMME1/P2-DIMMF1
2 CPUs & 16 DIMMs (Unbalanced: not recommended)	CPU1: P1-DIMMC1/P1-DIMMB1/P1-DIMMA1/P1-DIMMA2/P1-DIMMD2/P1-DIMMD1/P1-DIMME1/P1-DIMMF1 CPU2: P2-DIMMC1/P2-DIMMB1/P2-DIMMA1/P2-DIMMA2/P2-DIMMD2/P2-DIMMD1/P2-DIMME1/P2-DIMMF1

**PCI-E M.2 Slot Installation**

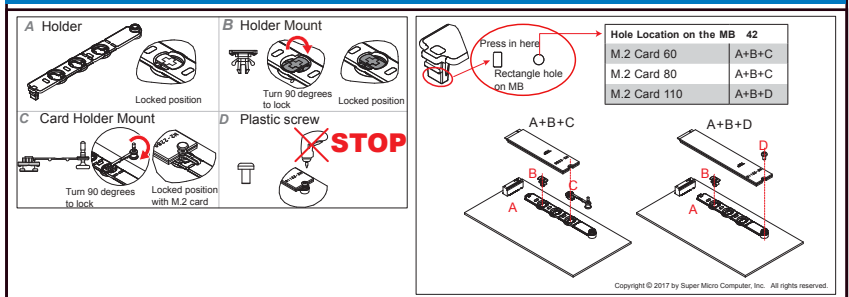

**Back Panel I/O Connectors**

