

**CONTACT INFORMATION**

- www.supermicro.com (Email: support@supermicro.com)
- Manuals: <http://www.supermicro.com/support/manuals>
- Drivers & Utilities: <ftp://ftp.supermicro.com>
- Safety: [http://www.supermicro.com/about/policies/safety\\_information.cfm](http://www.supermicro.com/about/policies/safety_information.cfm)

**PACKAGE CONTENTS** (Applies to individual-pack only)

- One (1) Supermicro Motherboard
- Two (2) SATA Cables
- One (1) I/O Shield
- One (1) Quick Reference Guide

**Motherboard Layout and Features**

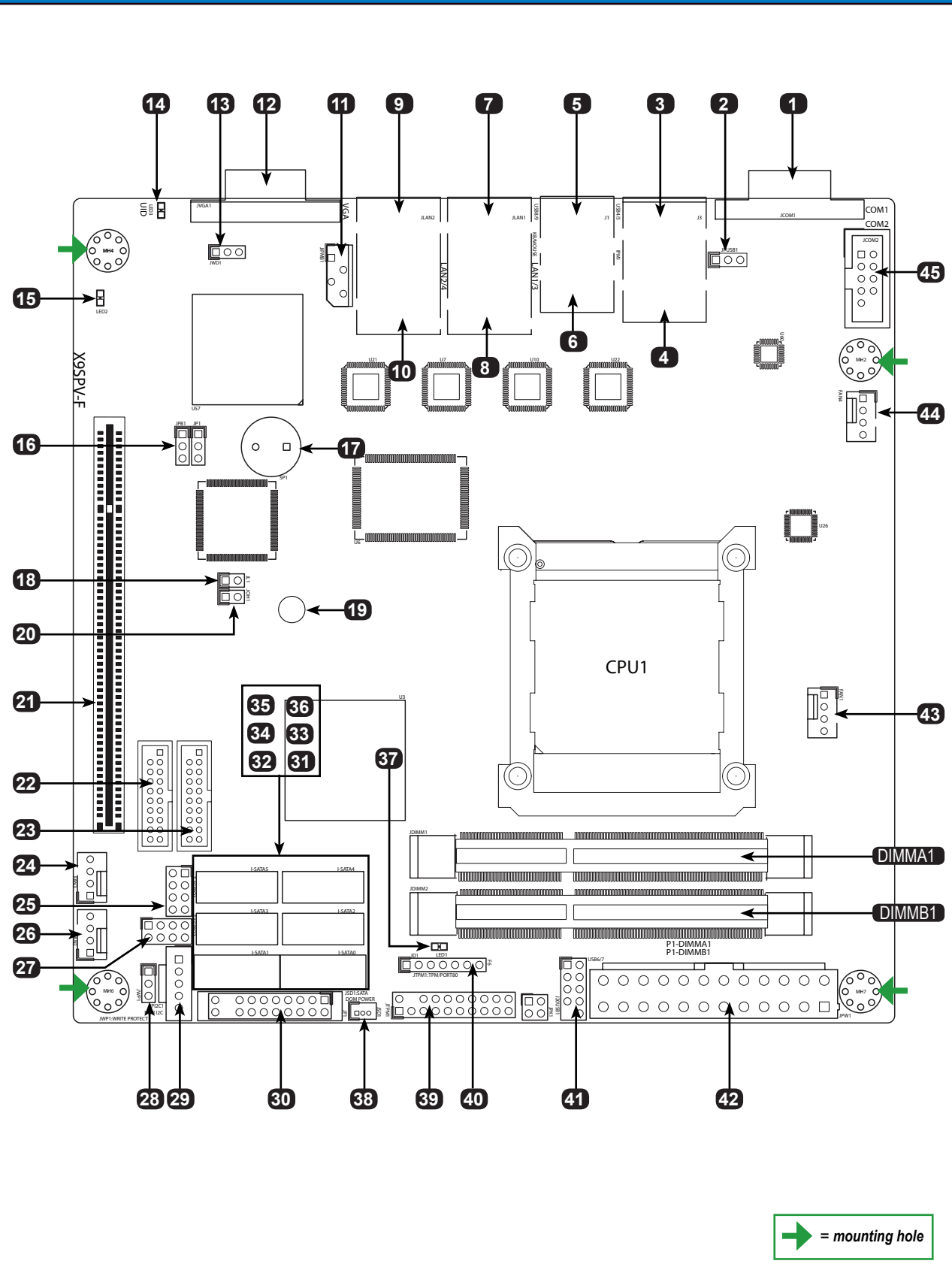

Note: Graphics shown in this quick reference guide are for illustration only. Your components may or may not look exactly the same as drawings shown in this guide.

**Jumpers, Connectors and LED Indicators**

**Jumpers**

Item #	Jumper	Description	Default
16	JPB1	BMC (IPMI) Enable/Disable	Pins 1-2 (Enabled)
19	JBT1	CMOS Clear	Open (Short pads to clear)
13	JWD1	Watch Dog Timer	Pins 1-2 (Reset)
28	JWP1	BIOS Write Protect	Pins 1-2 (Enabled)
2	JPUSB1	USB Wake-up	Pins 2-3 (Disable)

**Connectors**

Item #	Connector	Description
21	SLOT1	PCI-E x16 Gen 2 Slot
18	JL1	Chassis Intrusion Header
20	JOH1	Overheat LED
23, 22, 41	USB 0/1, 2/3, 6/7	USB 0/1, 2/3 (USB 3.0 Headers), 6/7 (USB 2.0 Header)
4, 6	USB 4/5, USB 8/9	Backpanel USB Ports
43, 26, 24, 44	FAN1~4	CPU Fan, System Fan and Auxilliary Fan Headers
25, 27	T-SGPIO1, T-SGPIO2	Serial General Purpose I/O headers
29	JPI2C1	JPI2C, PWR supply (I2C) System Management Bus
30	JF1	Front Panel Control Header
38	JSD1	DOM (Disk on Module) Power Connector
39	JTPM1	TPM Header
17	SP1	Onboard Speaker/Buzzer
40	JD1	Power LED/Speaker Header
31, 32, 33, 34, 35, 36	I-SATA0~I-SATA5	SATA Connectors (White: SATA 3, Black: SATA 2)
42	JPW1	24-Pin ATX Power Connector
1, 45	COM1, COM2	Serial Ports (COM1 on the Back Panel, COM2 Header)
3	IPMI	IPMI Port
5	KB/MOUSE	Combination PS/2 Keyboard or Mouse Port
7, 9	LAN1, LAN2	LAN1, LAN2 Gb Ethernet Ports
8, 10	LAN3, LAN4	LAN3, LAN4 Gb Ethernet Ports (X9SPV-LN4F only)
12	VGA	VGA Port
11	JIPMB1	4-pin External BMC I2C Header (for an IPMI card)

**LED Indicators**

Item #	LED	Description	Color/State	Status
37	LED1	Standby Power LED		
15	LED2	IPMI Heartbeat LED		
14	LED3	Unsupported Memory LED		

Note: Refer to Chapter 2 of the User Manual for detailed information on jumpers, connectors, and LED indicators.

**Memory Support**

This motherboard supports up to 16 GB of DDR3 ECC SODIMMs 1066/1333 MHz memory in 2 SODIMM slots.

Note: For memory optimization, use only DIMM modules that have been validated by Supermicro. For the latest memory updates, please refer to our website at <http://www.supermicro.com/products/motherboard>.

**DIMM Installation**

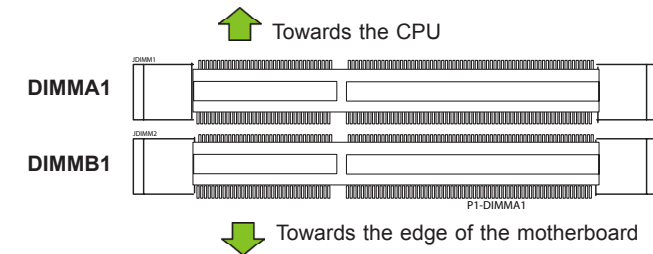

**Memory Population Guidelines**

When installing memory modules, the DIMM slots should be populated in the following order: DIMMA1, DIMMB1

**Front Panel Control (JF1)**

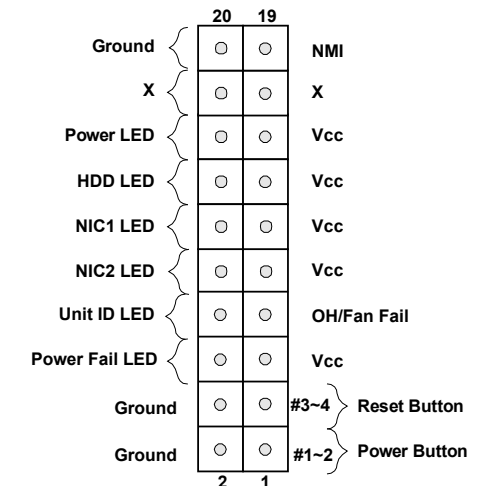

**Back Panel IO Connectors**

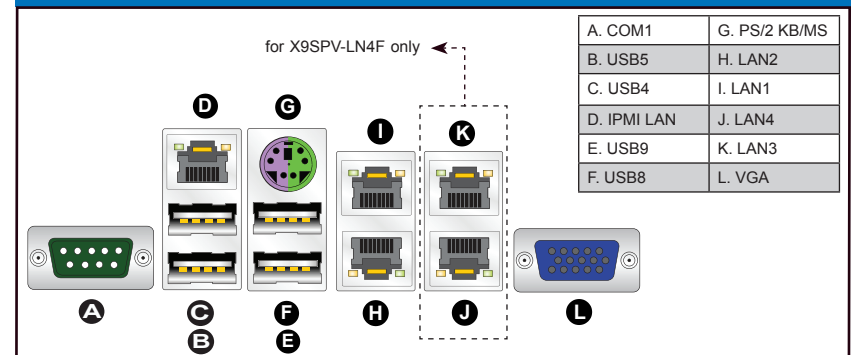

Note: Refer to Chapter 2 of the User Manual for detailed information on memory support and CPU/motherboard installation instructions.