



X12SAE
X12SCA-F

ENGLISH

繁體中文

简体中文

日本語

한국어

QUICK REFERENCE GUIDE

Revision 1.0b

Standardized Warning Statements

Motherboards

About Standardized Warning Statements

The following statements are industry standard warnings, provided to warn the user of situations which can potentially cause a bodily injury. Should you have questions or experience difficulty, contact Supermicro's Technical Support Department for assistance. Only certified technicians should attempt to install or configure components.

Read this section in its entirety before installing or configuring components in the Supermicro chassis.



WARNING: This product can expose you to chemicals including lead, known to the State of California to cause cancer and birth defects or other reproductive harm. For more information, go to www.P65Warnings.ca.gov.

Battery Handling



Warning!

There is a danger of explosion if the battery is replaced incorrectly. Replace the battery only with the same or an equivalent type recommended by the manufacturer. Dispose of used batteries according to the manufacturer's instructions.

警告

電池更換不當會有爆炸危險。請使用製造商建議之相同或功能相當的電池更換原有電池。請按照製造商的說明指示處理廢棄舊電池。

警告

電池更換不當會有爆炸危險。請只使用同類電池或製造商推薦的功能相當的電池更換原有電池。請按製造商的說明處理廢舊電池。

電池の取り扱い

電池交換が正しく行われなかった場合、破裂の危険性があります。交換する電池はメーカーが推奨する型、または同等のものを使用下さい。使用済電池は製造元の指示に従って処分して下さい。

경고!

배터리가 올바르게 교체되지 않으면 폭발의 위험이 있습니다. 기존 배터리와 동일하거나 제조사에서 권장하는 동등한 종류의 배터리로만 교체해야 합니다. 제조사의 안내에 따라 사용된 배터리를 처리하여 주십시오.

هناك خطر من انفجار في حالة استبدال البطارية بطريقة غير صحيحة فعليك استبدال البطارية فقط بنفس النوع أو ما يعادلها كما أوصت به الشركة المصنعة تخلص من البطاريات المستعملة وفقا لتعليمات الشركة الصانعة

限用物質含有情況標示聲明書

Declaration of the Presence Condition of the Restricted Substances Marking

設備名稱：主機板 / Motherboard Equipment name						
型號（型式）：X12SAE, X12SCA-F Type designation (Type)						
單元 Unit	限用物質及其化學符號 Restricted substances and its chemical symbols					
	鉛Lead (Pb)	汞Mercury (Hg)	鎘Cadmium (Cd)	六價鉻 Hexavalent chromium (Cr ⁺⁶)	多溴聯苯 Polybrominated biphenyls (PBB)	多溴二苯醚 Polybrominated diphenyl ethers (PBDE)
印刷電路板 組件 (PCBA)	—	○	○	○	○	○
連接器 (Connector)	—	○	○	○	○	○
鈕扣電池 (Coin Battery)	○	○	○	○	○	○
電子零件 (Electronic component)	—	○	○	○	○	○
<p>備考1. “超出0.1 wt %” 及 “超出0.01 wt %” 係指限用物質之百分比含量超出百分比含量基準值。</p> <p>Note 1: “Exceeding 0.1 wt %” and “exceeding 0.01 wt %” indicate that the percentage content of the restricted substance exceeds the reference percentage value of presence condition.</p> <p>備考2. “○” 係指該項限用物質之百分比含量未超出百分比含量基準值。</p> <p>Note 2: “○” indicates that the percentage content of the restricted substance does not exceed the percentage of reference value of presence.</p> <p>備考3. “—” 係指該項限用物質為排除項目。</p> <p>Note 3: The “—” indicates that the restricted substance corresponds to the exemption.</p>						

AMI BIOS POST Codes

About AMI BIOS POST Codes

The table below lists some of AMI BIOS POST codes for this motherboard. For more information, refer to https://www.supermicro.com/manuals/other/AMI_AptioV_BIOS_POST_Codes_for_SM_Motherboards.pdf.

Code	Description
0x32	CPU post-memory initialization is started
0x55	No Memory detected or memory failed
0x63	CPU DXE initialization is started
0x69	North Bridge DXE initialization is started
0x70	South Bridge DXE initialization is started
0x92	PCI Bus initialization is started
0x99	Super IO Initialization
0x9A	USB initialization is started
0xA0	IDE initialization is started
0xA9	Boot into BIOS setup menu
0xAE	Legacy Boot event
0xB2	Legacy Option ROM Initialization
0xB4	USB hot plug
0xD6	No console output devices are found
0xD7	No console input devices are found
0xF2	Recovery process started
0xF9	Recovery capsule is not found

M.2 Device Installation Instructions

M.2 Device Installation

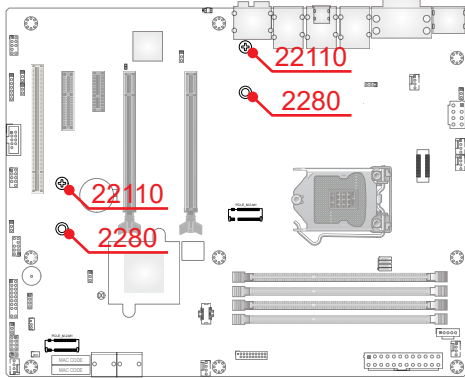

Type 2280

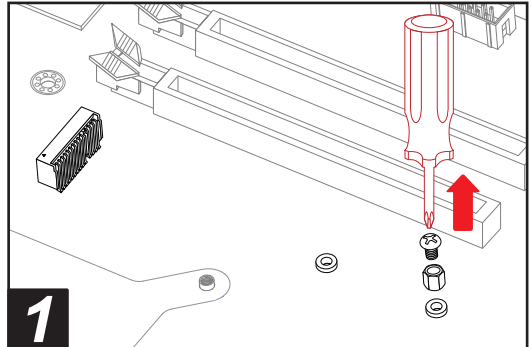

Type 22110

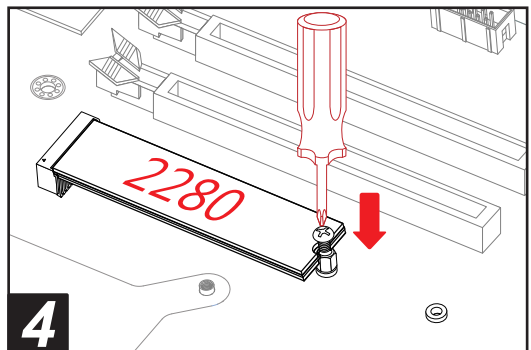
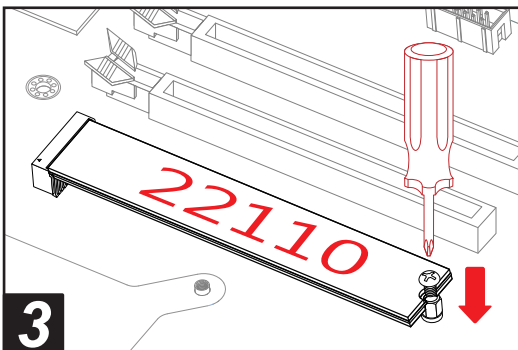
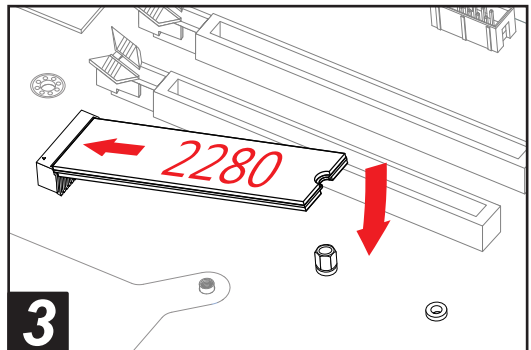
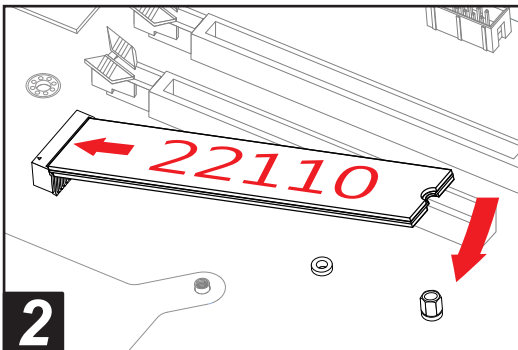
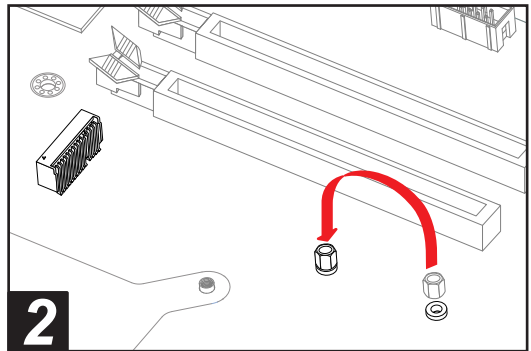
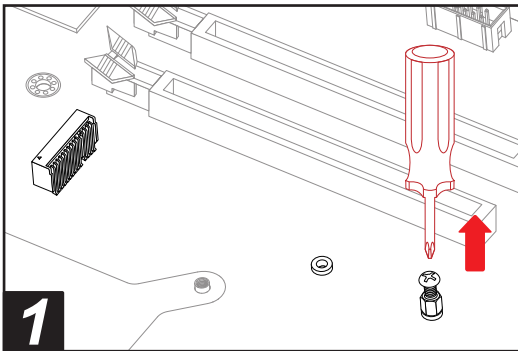

Notes

PACKAGE CONTENTS

- One Supermicro Motherboard
- One I/O Shield
- Four SATA Cables
- One Quick Reference Guide

Jumpers and Connectors

Jumpers

Jumper	Description	Default
JBT1	Clear CMOS (onboard)	Short Pads to Clear CMOS
JD1	Speaker Buzzer	Pins 1-4: External Speaker Pins 3-4: Buzzer
JPAC1	Audio Enable	Pins 1-2 (Enabled)
JPG1	VGA Enable (for X12SCA-F only)	Pins 1-2 (Enabled)
JPL1/2	LAN1/LAN2 Enable/Disable	Pins 1-2 (Enabled)
JPME2	Intel Manufacturing Mode	Pins 1-2 (Normal)
JWD1	Watch Dog Function Enable	Pins 1-2 (RST)

Connectors

Connector	Description
12V_PUMP_PWR1	12V 4-pin Power Connector for CPU Liquid Cooling Pump
AUDIO	High Definition Audio Ports (Back Panel)
AUDIO FP	Front Panel Audio Header
B3	Onboard Battery
COM1	COM Header
CPU_FAN 1 ~ CPU_FAN 2	CPU Fan Headers
CPU SLOT4 PCI-E 3.0 x8 (1Inx16)	PCIe 3.0 x16 Slot (PCIe 3.0 x8 link)
CPU SLOT6 PCI-E 3.0 x16	PCIe 3.0 x16 Slot (PCIe 3.0 x16 link) or PCIe 3.0 x8 (when CPU Slot4 is Populated)
DP/HDMI	DisplayPort Connector/High Definition Multimedia Interface (HDMI)
DVI	Digital Video Interface (DVI-D)
I-SATA0~3	Intel Serial ATA (SATA 3.0) Ports 0~3 (6Gb/sec)
IPMI_LAN	Dedicated IPMI LAN Port (for X12SCA-F only)
JF1	Front Control Panel Header
JL1	Chassis Intrusion Header
JLED1	3-pin Power LED Header
JPI2C1	Power Supply SMBus I2C Header
JPW1	24-pin ATX Main Power Connector (Required)
JPW2	+12V 8-pin CPU Power Connector (Required)
JSD1	SATA DOM (Disk On Module) Power Connector
JSTBY1	Standby Power Header (5V Standby Header)
JTPM1	Trusted Platform Module (TPM) Header (Supports TPM 2.0 only)
LAN1/2	LAN1: 1Gb/LAN2: 2.5Gb
PCH SLOT2 PCI-E 3.0 x4	PCIe 3.0 x4 Slot
PCH SLOT3 PCI-E 3.0 x1	PCIe 3.0 x1 Slot (for X12SAE only)
PCI-E_M.2-M1, M2	PCIe M.2 Connectors 1 and 2 (PCIe 3.0 x4 link), Small Form Factor Devices and Other Portable Devices for High Speed NVMe SSDs
SLOT1 PCI 33MHz	PCI Slot, 32 Bit/33MHz with 5V Single Voltage
SP1	Internal Speaker/Buzzer
SYS_FAN1 ~ SYS_FAN3	System Fan Headers
UID	Unit Identifier (UID) Switch (for X12SCA-F only)
USB0/1	Front Access USB 2.0 Header
USB2/3	Back Panel USB 3.2 Gen 1 Ports (Type A)
USB4/5	Front Access USB 3.2 Gen 1 Header
USB6/7	Back Panel USB 3.2 Gen 2 Ports (USB6: Type C, USB7: Type A)
USB8/9	Back Panel USB 3.2 Gen 2 Ports (Type A)
USB10	Front Panel Accessible USB 3.2 Gen 2 20-pin Connector
VGA	VGA Port (for X12SCA-F, IPMI only)

CONTACT INFORMATION

- www.supermicro.com (Email: support@supermicro.com)
- Manuals: <http://www.supermicro.com/support/manuals>
- Drivers & Utilities: <https://www.supermicro.com/wftp/driver/>
- Safety: http://www.supermicro.com/about/policies/safety_information.cfm

LED Indicators

LED Indicators

LED	Description	Color/State
BMC_HB_LED	X12SCA-F: BMC Heartbeat LED X12SAE: Standby Power LED	X12SCA-F: Green Blinking (Normal) 12SAE: Solid Green (Standby Power On)
CATERR_LED	Catastrophic Error LED	Solid Orange: System CATERR
LED4	UID LED (for X12SCA-F, IPMI only)	Blue on: Unit Identified
PWR_LED	Onboard Power LED	Green on: Power on

CPU & Memory Support

The X12SAE/X12SCA-F motherboard supports a single Intel® Xeon® W-1200 series, 10th Gen Core™ i9/i7/i5/i3 series processor, up to 128GB of Unbuffered (UDIMM) ECC/non-ECC memory, with speeds of up to 2933MHz (2DPC) in four 288-pin memory slots. Populating these DIMM slots with a pair of memory modules of the same type and same size will result in interleaved memory, which will improve memory performance.

-  **Notes:** 1) For memory optimization, use only DIMM modules that have been validated by Supermicro. For the latest memory updates, please refer to our website at <http://www.supermicro.com/products/motherboard>.
- 2) Always connect the power cord last, and always remove it before adding, removing, or changing any hardware components.
- 3) The 10th Gen Core-i series processor supported by this motherboard is limited. For more detailed information, please refer to Supermicro and Intel websites.
- 4) The Intel W-1200 series processor supports IGFX (Intel Graphics) via UEFI GOP driver, not via Legacy VBIOS.

DIMM Memory Installation

 Towards the CPU

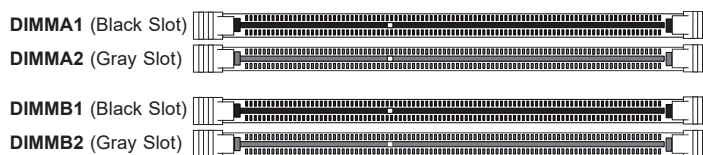

Memory Population Guidelines

When installing memory modules, the DIMM slots should be populated in the following order: DIMMA2, DIMMB2, then DIMMA1, DIMMB1.

- Always use DDR4 DIMM modules of the same size, type, and speed.
- Mixed DIMM speeds can be installed. However, all DIMMs will run at the speed of the slowest DIMM.

Recommended Population (Balanced)				
DIMMA1	DIMMB1	DIMMA2	DIMMB2	Total System Memory
		2GB DIMM	2GB DIMM	4GB
2GB DIMM	2GB DIMM	2GB DIMM	2GB DIMM	8GB
		4GB DIMM	4GB DIMM	8GB
4GB DIMM	4GB DIMM	4GB DIMM	4GB DIMM	16GB
		8GB DIMM	8GB DIMM	16GB
8GB DIMM	8GB DIMM	8GB DIMM	8GB DIMM	32GB
		16GB DIMM	16GB DIMM	32GB
16GB DIMM	16GB DIMM	16GB DIMM	16GB DIMM	64GB
		32GB DIMM	32GB DIMM	64GB
32GB DIMM	32GB DIMM	32GB DIMM	32GB DIMM	128GB

NOTES

- Graphics shown in this quick reference guide are for illustration only. Your components may or may not look exactly the same as drawings shown in this guide.
- Refer to Chapter 2 of the User Manual for detailed information on jumpers, connectors, LED indicators, memory support and CPU/motherboard installation instructions.

CPU Installation

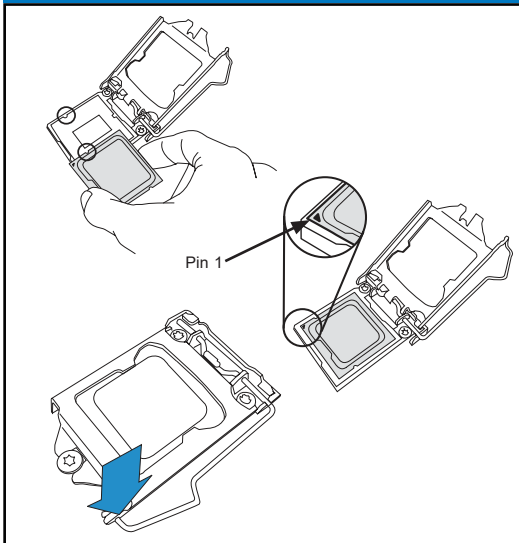

Heatsink Installation

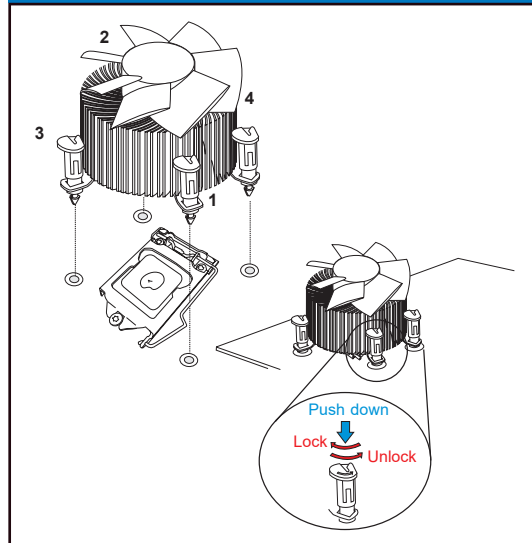

Front Control Panel (JF1)

Ground	20	19	NMI
X			X
Power LED			Vcc
HDD LED			Vcc
NIC1 LED			Vcc
NIC2 LED			Vcc
OH/Fan Fail LED			Vcc
Power Fail LED			Vcc
Ground			#3~4 Reset Button
Ground			#1~2 Power Button
	2	1	

Back Panel I/O Connectors

A. DisplayPort 1.4	F. USB3: USB 3.2 Gen1 (Type A)	K. 2.5Gb LAN Port 2
B. HDMI Port 2.0a	G. USB2: USB 3.2 Gen1 (Type A)	L. USB9: USB 3.2 Gen2 (Type A)
C. VGA Port (for IPMI, X12SCA-F only)	H. 1Gb LAN Port 1	M. USB8: USB 3.2 Gen2 (Type A)
D. Digital Video Interface (DVI-D)	I. USB7: USB 3.2 Gen2 (Type A)	N. Center/LFE Out
E. Dedicated IPMI LAN Port (X12SCA-F only)	J. USB6: USB 3.2 Gen2 (Type C)	O. Surround Out
		P. S/PDIF Out
		Q. Line In
		R. Line Out
		S. Mic In
		T. UID Switch (X12SCA-F only)

X12SCA-F

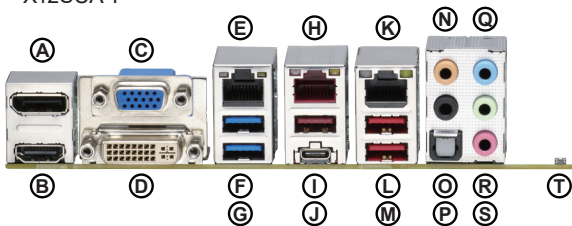

MNL-2263-QRG-10b

單一主機板包裝盒內容清單

- Supermicro 主機板 x1
- SATA 訊號線 x4
- 後擋板 x1
- 快速參考指南 x1

跳線器/連接埠

跳線器 (Jumper)		
跳線器	說明	預設值
JBT1	CMOS 組態資料清除 (內建)	設為短路來清除 CMOS 資料
JD1	喇叭 蜂鳴器	針腳 1-4 : 外接喇叭 針腳 3-4 : 蜂鳴器
JPAC1	啟用音源	針腳 1-2 (啟用)
JPG1	啟用/停用VGA (僅適用於X12SCA-F)	針腳 1-2 (啟用)
JPL1/2	啟用/停用LAN1/LAN2	針腳 1-2 (啟用)
JPME2	Intel製造模式	針腳 1-2 (正常)
JWD1	啟動系統監控 (Watch Dog) 功能	針腳 1-2 (重設)

連接埠 (Connector)	
連接埠	說明
12V_PUMP_PWR1	12V水冷幫浦電源插座
AUDIO	背板高清晰音效插孔
AUDIO FP	前面板音效接頭
B3	內建電池
COM1	COM1序列連接埠
CPU_FAN 1 ~ CPU_FAN 2	CPU (中央處理器) 風扇接頭
CPU SLOT4 PCI-E 3.0 x8 (INx16)	PCIe 3.0 x16插槽 · 支援PCIe 3.0 x8運作效能規格
CPU SLOT6 PCI-E 3.0 x16	PCIe 3.0 x16插槽 · 支援PCIe 3.0 x16 運作效能規格 (當CPU Slot4插槽安裝外接卡時 · 此插槽最高以 x8頻寬運作)
DP/HDMI	背板DisplayPort接頭和HDMI接頭
DVI	DVI接頭
I-SATA0~3	Intel 序列 ATA 介面 (SATA 3.0) 連接埠 0~3 (6Gb/秒)
IPMI_LAN	IPMI網路連接埠 (僅適用於X12SCA-F)
JF1	前控制面板接頭
JL1	機殼防盜裝置接頭
JLED1	3針腳電源指示燈接頭
JPI2C1	電源供應SMBus I2C接頭
JPW1	24針腳 ATX 主電源連接埠 (必備)
JPW2	+12伏特8針腳 CPU 電源連接埠 (必備)
JSD1	SATA DOM (磁碟模組) 電源連接埠
JSTBY1	待機電源接頭 (5V)
JTPM1	TPM 信任平台模組接頭 (僅支援TPM 2.0)
LAN1/2	LAN1 : 1Gb/LAN2 : 2.5Gb 乙太網路線連接埠
PCH SLOT2 PCI-E 3.0 x4	PCIe 3.0插槽 · 支援PCIe 3.0 x4運作效能規格
PCH SLOT3 PCI-E 3.0 x1	PCIe 3.0 插槽 · 支援PCIe 3.0 x1運作效能規格 (僅適用於X12SAE)
PCI-E_M.2-M1, M2	PCIe M.2 介面連接埠 (PCIe 3.0 x4) · 適用具高速傳輸 NVMe 介面之小尺寸以及其他可攜式M.2 固態硬碟 *PCIe為電腦匯流的一種規格 · M.2為固態硬碟的一種傳輸介面 · 而 NVMe 為非揮發性記憶體儲存裝置的一種標準。
SLOT1 PCI 33MHz	PCI 插槽 (32Bit/ 33MHz · 5V)
SP1	內建喇叭/蜂鳴器
SYS_FAN1 ~ SYS_FAN3	系統風扇接頭
UID	單位識別按鈕 (僅適用於X12SCA-F)
USB0/1	前面板 USB 2.0 規格連接埠 (註 : USB 完整譯名為「通用序列匯流排」)
USB2/3	背板USB 3.2 Gen 1 規格連接埠 (Type A)
USB4/5	前面板 USB 3.2 Gen 1 規格連接埠
USB6/7	背板USB 3.2 Gen 2 規格連接埠 (USB6: Type C, USB7: Type A)
USB8/9	背板USB 3.2 Gen 2 規格連接埠 (Type A)
USB10	USB 3.2 Gen 2規格連接埠 · 適用於連接機殼前面板Type C連接埠
VGA	VGA連接埠 (僅適用於X12SCA-F IPMI介面)

線上技術支援及下載

- 聯絡我們 (技術支援信箱) : www.supermicro.com (Email: support@supermicro.com)
- 產品手冊文件 : <http://www.supermicro.com/support/manuals>
- 驅動程式及工具程式 : <https://www.supermicro.com/wftp/driver/>
- 產品安全性須知 : http://www.supermicro.com/about/policies/safety_information.cfm

LED 指示燈

LED 指示燈

LED燈	說明	燈號顏色/情況
BMC_HB_LED	X12SCA-F : BMC運作指示燈 X12SAE : 待機電源指示燈	X12SCA-F : 綠燈閃爍 (BMC正常) 12SAE : 綠燈恆亮 (待機中)
CATERR_LED	主機故障識別燈 (需配合相關軟體)	橘燈恆亮 : 該機故障
LED4	單位識別指示燈 (僅適用於X12SCA-F IPMI介面)	藍燈恆亮 : 識別中
PWR_LED	內建電源指示燈	綠燈恆亮 : 開啟

中央處理器和記憶體支援

本主機板X12SAE/X12SCA-F支援單顆Intel® Xeon® W-1200系列、第十代Core™ i9/i7/i5/i3系列處理器。記憶體支援四條Unbuffered (UDIMM) ECC/Non-ECC DDR4，容量最高可達 128GB，及傳輸頻率最高可達2933MHz (2DPC) 288支針腳的記憶體插槽。欲取得雙通道效能，請安裝成對相同型號與速度之記憶體。

(Unbuffered DIMM，或做UDIMM，為「無緩衝雙通道記憶體模組」；ECC是Error Correction Code的縮寫，中譯為「錯誤修正碼」；DDR為「雙倍速動態隨機存取記憶體」。)

註：1) 請安裝使用本公司所認可的記憶體模組以達記憶體模組最佳化。更多的記憶體模組相關訊息，請參閱本公司網頁 (<http://www.supermicro.com/products/motherboard>)。

2) 增加、移除和更換任何硬體元件前，請務必先拔掉電源線。待確實完成所有程序後，再重新連接電源線。

3) 此主機板僅支援部分的Intel Core-i系列處理器，欲知更多產品支援訊息，請參閱Supermicro和Intel網站。

4) Intel W-1200系列處理器內建顯示功能僅支援UEFI GOP Driver (繪圖輸出通訊協定驅動程式)。

記憶體模組 (DIMM) 安裝方式

↑ 此面朝向中央處理器

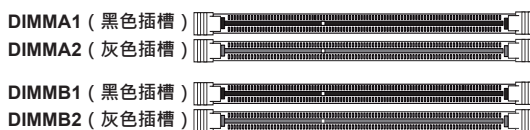

請依照以下說明及表格安裝記憶體模組：

- 請使用相同型號 (DDR4 DIMM) 與速度之記憶體。
- 若混合使用不同速度之記憶體，系統將依較低的記憶體速度執行。

建議插槽使用方式

DIMMA1	DIMMB1	DIMMA2	DIMMB2	Total System Memory
		2GB DIMM	2GB DIMM	4GB
2GB DIMM	2GB DIMM	2GB DIMM	2GB DIMM	8GB
		4GB DIMM	4GB DIMM	8GB
4GB DIMM	4GB DIMM	4GB DIMM	4GB DIMM	16GB
		8GB DIMM	8GB DIMM	16GB
8GB DIMM	8GB DIMM	8GB DIMM	8GB DIMM	32GB
		16GB DIMM	16GB DIMM	32GB
16GB DIMM	16GB DIMM	16GB DIMM	16GB DIMM	64GB
		32GB DIMM	32GB DIMM	64GB
32GB DIMM	32GB DIMM	32GB DIMM	32GB DIMM	128GB

備註

- 快速參考指南中的圖例僅供安裝及操作說明使用，可能與實際產品外觀不同。
- 欲知更多跳線器/連接埠/指示燈/記憶體/主機板/中央處理器的安裝相關資訊，請參閱《Supermicro X12SAE/X12SCA-F使用手冊》第二章。

中央處理器安裝方式

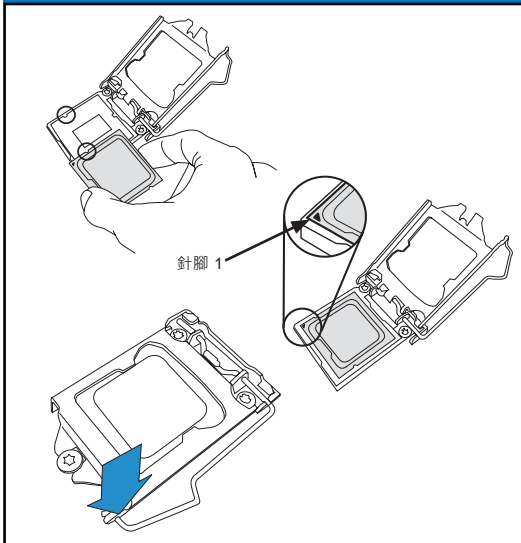

散熱器安裝方式

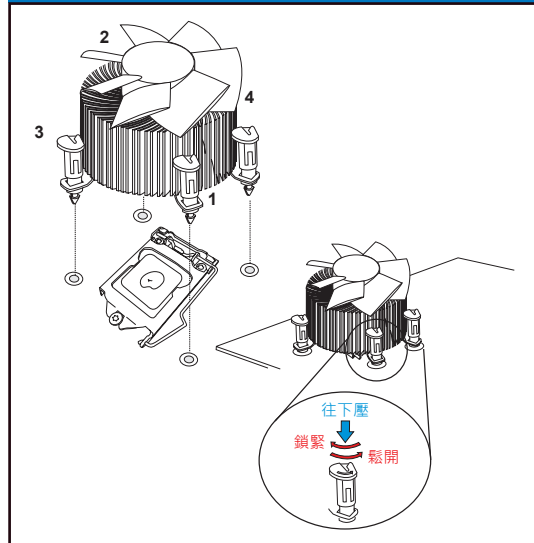

前控制面板配置 (JF1)

	20	19			20	19		
接地	○	○	非可遮蔽中斷		Ground	○	○	NMI
X	○	○	X		X	○	○	X
電源LED	○	○	Vcc電壓		Power LED	○	○	Vcc
硬碟機LED	○	○	Vcc電壓		HDD LED	○	○	Vcc
網卡1之LED	○	○	Vcc電壓		NIC1 LED	○	○	Vcc
網卡2之LED	○	○	Vcc電壓		NIC2 LED	○	○	Vcc
過熱及風扇故障LED	○	○	Vcc電壓		OH/Fan Fail LED	○	○	Vcc
電源故障LED	○	○	Vcc電壓		Power Fail LED	○	○	Vcc
接地	○	○	#3~4 重設鍵		Ground	○	○	#3~4 Reset Button
接地	○	○	#1~2 電源鍵		Ground	○	○	#1~2 Power Button
	2	1				2	1	

背板輸出/輸入連接埠

A. DisplayPort 1.4連接埠	F. USB3: USB 3.2 Gen1 連接埠 (Type A)	K. 2.5Gb網路連接埠2
B. HDMI 2.0a連接埠	G. USB2: USB 3.2 Gen1 連接埠 (Type A)	L. USB9: USB 3.2 Gen2 連接埠 (Type A)
C. VGA連接埠 (僅適用於X12SCA-F · IPMI)	H. 1Gb網路連接埠1	M. USB8: USB 3.2 Gen2 連接埠 (Type A)
D. DVI-D連接埠	I. USB7: USB 3.2 Gen2 連接埠 (Type A)	N. 中央/低音聲道輸出
E. IPMI網路連接埠 (僅適用於 X12SCA-F)	J. USB6: USB 3.2 Gen2 連接埠 (Type C)	O. 環繞聲道輸出
		P. S/PDIF輸出
		Q. 音效輸入
		R. 音效輸出
		S. 麥克風插孔
		T. 單位識別按鈕

MNL-2263-QRG-10b

单一主板包装盒内容清单

- Supermicro主板 x1
- SATA数据线 x4
- 后挡板 x1
- 快速参考指南 x1

跳线和连接器

跳帽 (Jumper)		
跳帽	说明	预设
JBT1	清除CMOS (内建)	短接管脚清除 CMOS
JD1	喇叭 蜂鸣器	针脚1-4: 外接喇叭 针脚3-4: 蜂鸣器
JPAC1	启用音源	针脚1-2 (启用)
JPG1	VGA启用 (仅限X12SCA-F)	针脚1-2 (启用)
JPL1/2	LAN1/LAN2启用/禁用	针脚1-2 (启用)
JPME2	Intel制造模式	针脚1-2 (正常)
JWD1	启用系统监控 (Watch Dog) 功能	针脚 1-2 (重设)

接口 (Connector)	
接口	说明
12V_PUMP_PWR1	用于CPU液体冷却泵的12V 4针脚电源接口
AUDIO	高清音频接口 (背板)
AUDIO FP	前面板音效接口
B3	内建电池
COM1	COM串口
CPU_FAN 1 ~ CPU_FAN 2	CPU风扇接口
CPU SLOT4 PCI-E 3.0 x8 (INx16)	PCIe 3.0 x16插槽 (PCIe 3.0 x8总线规格)
CPU SLOT6 PCI-E 3.0 x16	PCIe 3.0 x16插槽 (PCIe 3.0 x16总线规格) 或PCIe 3.0 x8 (PCIe插槽4被占用时)
DP/HDMI	DisplayPort显示接口/高清多媒体接口 (HDMI)
DVI	数字视频接口 (DVI-D)
I-SATA0~3	Intel串行ATA (SATA 3.0)接口0~3 (6Gb/秒)
IPMI_LAN	IPMI LAN接口 (仅限X12SCA-F)
JF1	前控制面板接口
JL1	机箱入侵检测接口
JLED1	3针脚电源LED接口
JPI2C1	电源 SMBus I2C 接口
JPW1	24针脚ATX主电源接口 (必备)
JPW2	+12V 8针脚CPU电源接口 (必备)
JSD1	SATA DOM (磁盘模组) 电源接口
JSTBY1	待机电源接口 (5V)
JTPM1	TPM 信任平台模组接口 (仅支持TPM 2.0)
LAN1/2	LAN1: 1Gb/LAN2: 2.5Gb
PCH插槽2 PCI-E 3.0 x4	PCIe 3.0 x4插槽
PCH插槽3 PCI-E 3.0 x1	PCIe 3.0 x1插槽 (仅限X12SAE)
PCI-E_M.2-M1, M2	PCIe M.2接口1和2 (PCIe 3.0 x4总线规格), 用于高速NVMe固态硬盘的小型设备和其他便携式设备
SLOT1 PCI 33MHz	PCI插槽, 32Bit/33MHz, 5V
SP1	内置喇叭/蜂鸣器
SYS_FAN1 ~ SYS_FAN3	系统风扇接口
UID	UID开关 (仅限X12SCA-F)
USB0/1	前置USB 2.0接口
USB2/3	背板USB 3.2 Gen 1接口 (Type A)
USB4/5	前置USB 3.2 Gen 1接口
USB6/7	背板USB 3.2 Gen 2接口 (USB6: Type C, USB7: Type A)
USB8/9	背板USB 3.2 Gen 2接口 (Type A)
USB10	前置USB 3.2 Gen 2 20针脚接口
VGA	VGA端口 (仅限X12SCA-F、IPMI)

线上技术支持及下载

- 联络我们（技术支持信箱）：www.supermicro.com（Email: support@supermicro.com）
- 产品手册文件：<http://www.supermicro.com/support/manuals>
- 驱动程序及工具：<https://www.supermicro.com/wftp/driver/>
- 产品安全性须知：http://www.supermicro.com/about/policies/safety_information.cfm

LED指示灯

LED指示灯

LED	说明	颜色/状态
BMC_HB_LED	X12SCA-F: BMC心跳指示灯 X12SAE: 待机电源指示灯	X12SCA-F: 绿色闪烁（正常） X12SAE: 绿色常亮（备用电源打开）
CATERR_LED	灾难性错误指示灯	橙色常亮: 系统灾难性错误
LED4	UID LED（仅限X12SCA-F, IPMI）	蓝灯常亮: 识别中
PWR_LED	内建电源指示灯	绿灯常亮: 开机

中央处理器和内存支持

X12SAE/X12SCA-F主板支持单颗Intel® Xeon® W-1200系列、第十代Core™ i9/i7/i5/i3系列处理器。内存支持四条Unbuffered (UDIMM) ECC/Non-ECC DDR4，容量最高可达 128GB，及传输频率最高可达2933MHz（2DPC）288支脚的内存插槽。欲取得双通道效能，请安装成对相同型号与速度之内存。

 备注：1) 请安装使用本公司所认可的内存模组以达内存模组最佳化。更多的内存模组相关资讯，请参阅本公司网页 <http://www.supermicro.com/products/motherboard>。

2) 增加、移除和更换任何硬件前，请务必先拔掉电源线。待确认完成所有操作后，再重新连接电源线。

3) 此主板仅支持部分第10代Core-i系列处理器。有关更多详细信息，请参阅Supermicro和Intel网站。

4) Intel W-1200系列处理器仅支持UEFI GOP驱动程序（Intel I GFX），而非VBIOS。

DIMM（内存模块）安装方式

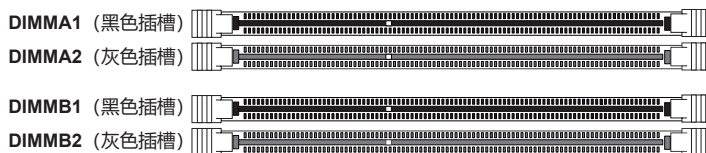

请依照以下说明及表格安装内存模块：

安装内存模块时，应按以下顺序插入DIMM插槽：DIMMA2、DIMMB2，然后DIMMA1、DIMMB1。

- 请使用相同型号（DDR4 DIMM）与速度之内存。
- 若混合使用不同速度之内存，系统将依较低的内存速度执行。

建议插槽使用方式				
DIMMA1	DIMMB1	DIMMA2	DIMMB2	系统内存总容量
		2GB DIMM	2GB DIMM	4GB
2GB DIMM	2GB DIMM	2GB DIMM	2GB DIMM	8GB
		4GB DIMM	4GB DIMM	8GB
4GB DIMM	4GB DIMM	4GB DIMM	4GB DIMM	16GB
		8GB DIMM	8GB DIMM	16GB
8GB DIMM	8GB DIMM	8GB DIMM	8GB DIMM	32GB
		16GB DIMM	16GB DIMM	32GB
16GB DIMM	16GB DIMM	16GB DIMM	16GB DIMM	64GB
		32GB DIMM	32GB DIMM	64GB
32GB DIMM	32GB DIMM	32GB DIMM	32GB DIMM	128GB

备注

- 快速参考指南中的图例仅供安装及操作说明使用，可能与实际产品外观不同。
- 欲知更多跳帽/接口/指示灯/内存/主板/中央处理器的安装相关资讯，请参阅《Supermicro X12SAE/X12SCA-F使用手册》第二章。

中央处理器安装方式

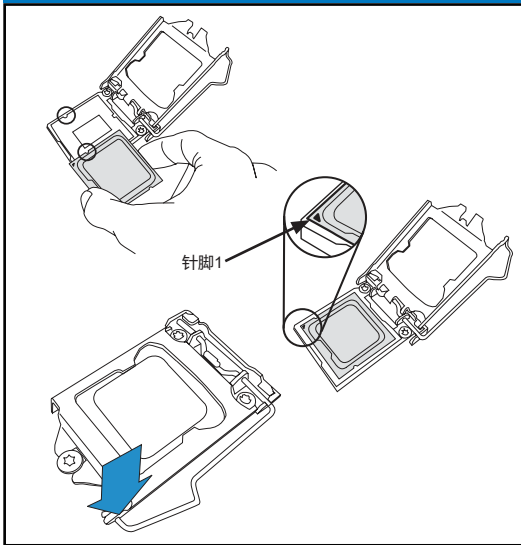

散热器安装方式

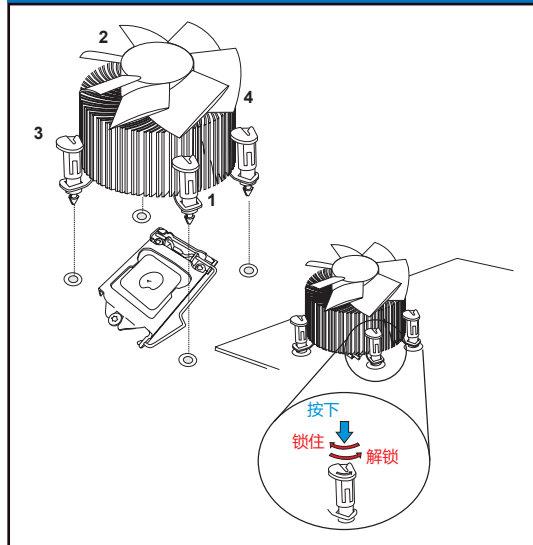

前控制面板配置 (JF1)

	20	19			20	19		
接地	○	○	不可屏蔽中断		Ground	○	○	NMI
X	○	○	X		X	○	○	X
电源LED	○	○	Vcc		Power LED	○	○	Vcc
硬盘LED	○	○	Vcc		HDD LED	○	○	Vcc
网卡1 LED	○	○	Vcc		NIC1 LED	○	○	Vcc
网卡2 LED	○	○	Vcc		NIC2 LED	○	○	Vcc
过热/风扇故障LED	○	○	Vcc		OH/Fan Fail LED	○	○	Vcc
电源故障LED	○	○	Vcc		Power Fail LED	○	○	Vcc
接地	○	○	#3~4 重启键		Ground	○	○	#3~4 Reset Button
接地	○	○	#1~2 电源键		Ground	○	○	#1~2 Power Button
	2	1				2	1	

背板输出/输入接口

A. DisplayPort 1.4接口	F. USB3: USB 3.2 Gen1 (Type A)	K. 2.5Gb LAN2接口
B. HDMI 2.0a接口	G. USB2: USB 3.2 Gen1 (Type A)	L. USB9: USB 3.2 Gen2 (Type A)
C. VGA接口 (仅限X12SCA-F、IPMI)	H. 1Gb LAN1接口	M. USB8: USB 3.2 Gen2 (Type A)
D. DVI-D接口	I. USB7: USB 3.2 Gen2 (Type A)	N. 中央/低音声道输出
E. IPMI LAN接口 (仅限X12SCA-F)	J. USB6: USB 3.2 Gen2 (Type C)	O. 环绕声道输出
		P. S/PDIF输出
		Q. 音效输入
		R. 音效输出
		S. 麦克风插孔
		T. UID开关 (仅限X12SCA-F)

MNL-2263-QRG-10b

© 2025 美超微股份有限公司 (以下简称「本公司」) 版权所有。未经本公司书面同意，严禁重製本文件部分或全部内容。所有商標均為所屬公司所有。所有提供資訊於印刷之際均為最新且正確。

マザーボードの配置および機能

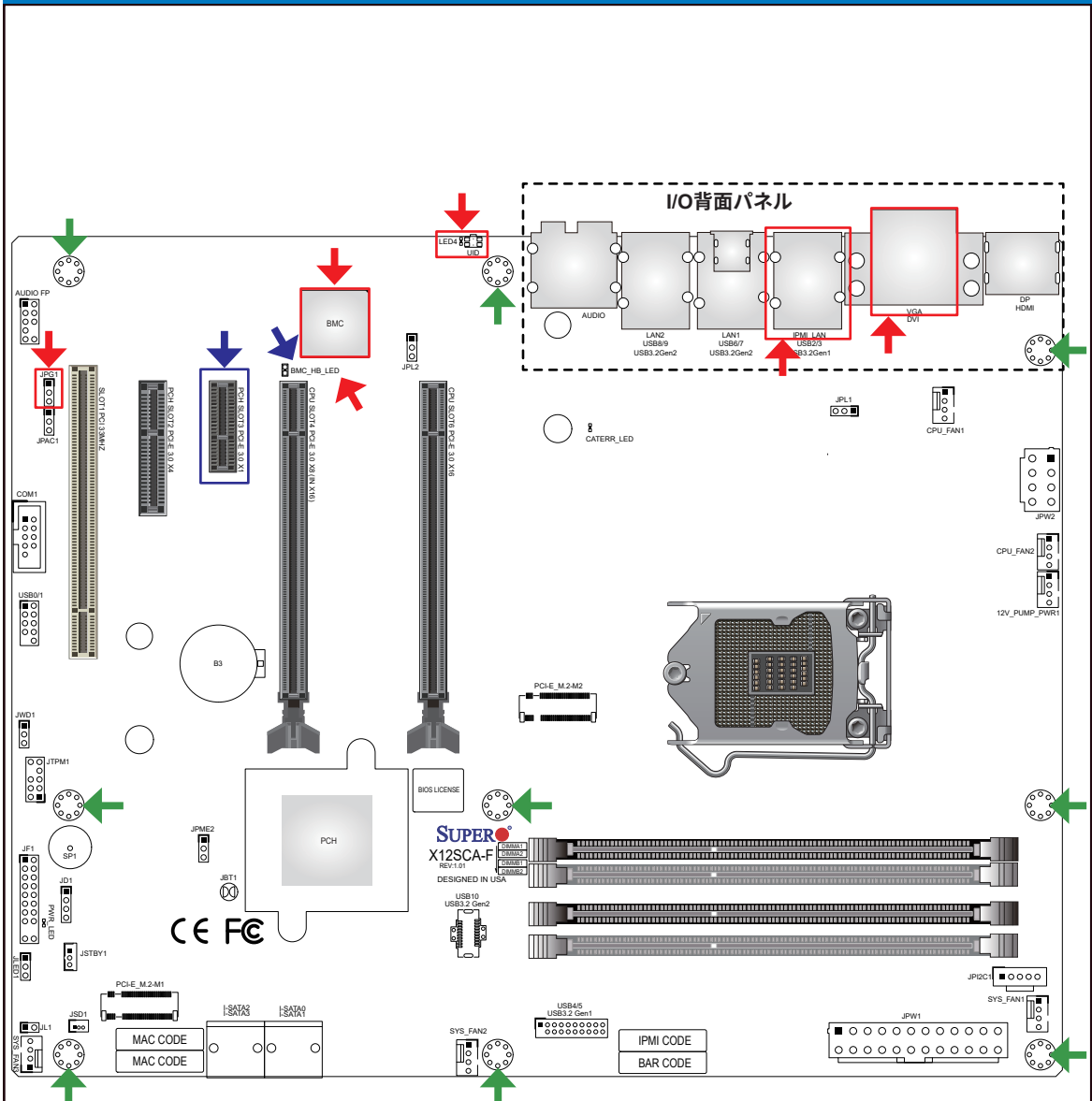

➔ = 取り付け穴
➔ = X12SAEのみ
➔ = X12SCA-Fのみ

パッケージ内容

- Supermicroマザーボード x 1
- SATAケーブル x 4
- I/Oシールド x 1
- クイックレファレンガイド x 1

ジャンパーおよびコネクタ

ジャンパー		
ジャンパ	説明	デフォルト
JBT1	CMOSクリア (基板上)	CMOSクリア用のショートパッド
JD1	スピーカー ブザー用ヘッダー	ピン1~4:外付けスピーカー ピン 3~4:ブザー
JPAC1	音声有効	ピン 1-2 (有効)
JPG1	VGA有効化 (X12SCA-Fのみ)	ピン1~2 (有効)
JPL1/2	LAN1/LAN2 有効/無効	ピン1~2 (有効)
JPME2	Intelマニファクチャーモード	ピン1~2 (通常)
JWD1	ウォッチドッグ機能有効	ピン1~2 (RST)

コネクタ	
コネクタ	説明
12V_PUMP_PWR1	CPU水冷ポンプ用12V 4ピン電源コネクタ
オーディオ	ハイディフィニション オーディオポート (バックパネル)
AUDIO FP	フロントパネルオーディオヘッダー
B3	オンボードバッテリー
COM1	COMヘッダー
CPU_FAN 1 ~ CPU_FAN 2	CPUファンヘッダー
CPU スロット4 PCI-E 3.0 x8 (入力x16)	PCIe 3.0 x16スロット (PCIe 3.0 x8リンク)
CPU スロット6 PCI-E 3.0 x16	PCIe 3.0 x16スロット (PCIe 3.0 x16リンク) またはPCIe 3.0 x8 (CPUスロット4が使用されている場合)
DP/HDMI	DisplayPortコネクタ/高解像度マルチメディアインターフェース (HDMI)
DVI	Digital Video Interface (DVI-D)
I-SATA0~3	Intel シリアルATA (SATA 3.0) ポート0~3 (6Gb/秒)
IPMI_LAN	専用IPMI LANポート (X12SCA-Fのみ)
JF1	フロント制御パネルヘッダー
JL1	筐体侵入ヘッダー
JLED1	3ピン電源LEDヘッダー
JPI2C1	電源SMBus I2Cヘッダー
JPW1	24ピンATX主電源コネクタ (必須)
JPW2	+12V 8ピンCPU電源コネクタ (必須)
JSD1	SATA DOM (ディスクオンモジュール) 電源コネクタ
JSTBY1	スタンバイ電源ヘッダー (5Vスタンバイヘッダー)
JTPM1	Trusted Platform Module (TPM) ヘッダー (TPM2.0のみ対応)
LAN1/2	LAN1: 1Gb/LAN2: 2.5Gb
PCH スロット2 PCI-E 3.0 x4	PCIe 3.0 x4スロット
PCH スロット3 PCI-E 3.0 x1	PCIe 3.0 x1 スロット (X12SAEのみ)
PCI-E_M.2-M1、M2	PCIe M.2 コネクタ1および2 (PCIe 3.0 x4リンク)、スモール フォームファクタデバイスおよびその他の高速NVMe SSD向け携帯機器
スロット1 PCI 33MHz	PCI スロット、32ビット/33MHz (5V 単一電圧付き)
SP1	内部スピーカー/ブザー
SYS_FAN1~SYS_FAN3	システムファンヘッダー
UID	ユニット識別子 (UID) スイッチ (X12SCA-Fのみ)
USB0/1	フロントアクセスUSB 2.0 ヘッダー
USB2/3	バックパネルUSB 3.2 Gen 1ポート (タイプA)
USB4/5	フロントアクセスUSB 3.1 Gen1ヘッダー
USB6/7	バックパネルUSB 3.2 Gen 2ポート (USB6: タイプC、USB7: タイプA)
USB8/9	バックパネルUSB 3.2 Gen 2ポート (タイプA)
USB10	フロントパネルアクセス式USB 3.2 Gen 2 20ピンコネクタ
VGA	VGAポート (X12SCA-F、IPMIのみ)

お問い合わせ先

- www.supermicro.com (電子メール: support@supermicro.com)
- マニュアル: <http://www.supermicro.com/support/manuals>
- ドライバおよびユーティリティ: <https://www.supermicro.com/wftp/driver/>
- 安全に関するご注意: http://www.supermicro.com/about/policies/safety_information.cfm

LEDインジケータ

LEDインジケータ

LED	説明	色/状態
BMC_HB_LED	X12SCA-F: BMC Heartbeat LED X12SAE: スタンバイ電源LED	X12SCA-F: 緑色点滅 (ノーマル) X12SAE: 緑色点灯 (スタンバイ電源オン)
CATERR_LED	破壊的エラーLED	オレンジ色点灯: システムCATERR
LED4	UID LED (X12SCA-F、IPMIのみ)	青色点灯: 単位識別済み
PWR_LED	基板上の電源LED	緑色点灯: 電源オン

CPUおよびメモリのサポート

X12SAE/X12SCA-Fマザーボードは、シングルIntel® Xeon® W-1200シリーズ、第10世代Gen Core™ i9/i7/i5/i3シリーズプロセッサ、最大128GBの非バッファ (UDIMM) ECC/非ECCメモリ、4個の288ピンメモリスロットに最大2933MHz (2DPC) の速度に対応します。DIMMスロットに種類とサイズが同一の1組のメモリモジュールを取り付けることでインターリーブメモリとなり、メモリ性能が向上します。

-  注: 1) メモリを最適化するために、Supermicroにより検証されたDIMMモジュールのみを使用してください。メモリに関する最新情報については、当社のWebサイト (<http://www.supermicro.com/products/motherboard>) を参照してください。
- 2) 電源コードは必ず一番最後に繋げるようにして、常にハードウェアコンポーネントを追加、取り外し、または交換する前に外すようにしてください。
 - 3) このマザーボードが対応する第10世代Core-iシリーズプロセッサは限定されています。より詳しい詳細については、SupermicroとIntelのウェブサイトを参照してください。
 - 4) Intel W-1200シリーズプロセッサは、従来のVBIOSではなくUEFI GOPドライバー経由でIGFX (Intel Graphics) に対応します。

DIMMメモリの取り付け

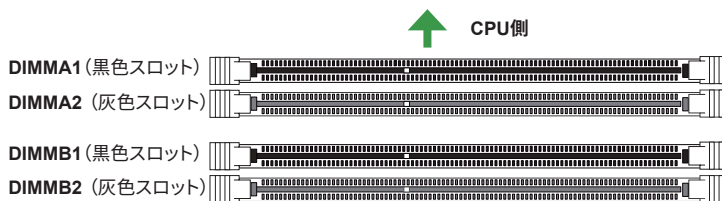

メモリを挿入する際のガイドライン

メモリモジュールを取り付ける際、DIMMスロットは以下の順序で装着してください。DIMMA2、DIMMB2、その後、DIMMA1、DIMMB1。

- 必ずサイズ、種類、速度が同じDDR4 DIMMモジュールを使用してください。
- 速度が異なるDIMMを組み合わせることは可能です。ただし、すべてのDIMMは、最も遅いDIMMの速度で動作します。

推奨される挿入例 (バランス型)

DIMMA1	DIMMB1	DIMMA2	DIMMB2	総システムメモリ
		2GB DIMM	2GB DIMM	4GB
2GB DIMM	2GB DIMM	2GB DIMM	2GB DIMM	8GB
		4GB DIMM	4GB DIMM	8GB
4GB DIMM	4GB DIMM	4GB DIMM	4GB DIMM	16GB
		8GB DIMM	8GB DIMM	16GB
8GB DIMM	8GB DIMM	8GB DIMM	8GB DIMM	32GB
		16GB DIMM	16GB DIMM	32GB
16GB DIMM	16GB DIMM	16GB DIMM	16GB DIMM	64GB
		32GB DIMM	32GB DIMM	64GB
32GB DIMM	32GB DIMM	32GB DIMM	32GB DIMM	128GB

注

- このクイックリファレンスガイドに掲載される図は、説明のみを目的としています。ご利用のコンポーネントは、このガイドに掲載される図とまったく同じではない場合があります。
- ジャンパー、コネクタ、LEDインジケータ、対応メモリ、およびCPU/マザーボードの設置方法に関する詳細については、ユーザーマニュアルの第2章を参照してください。

CPUの設置

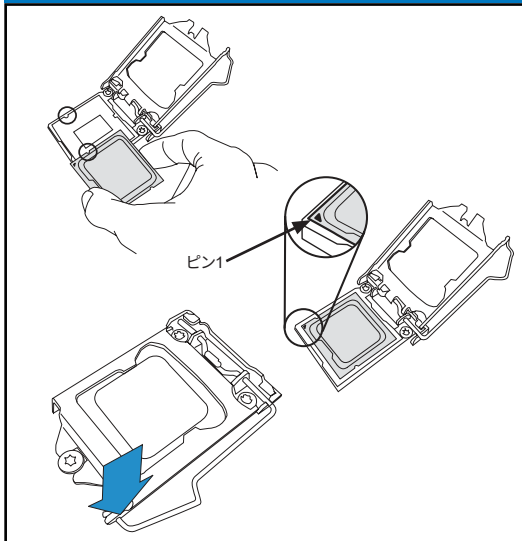

ヒートシンクの設置

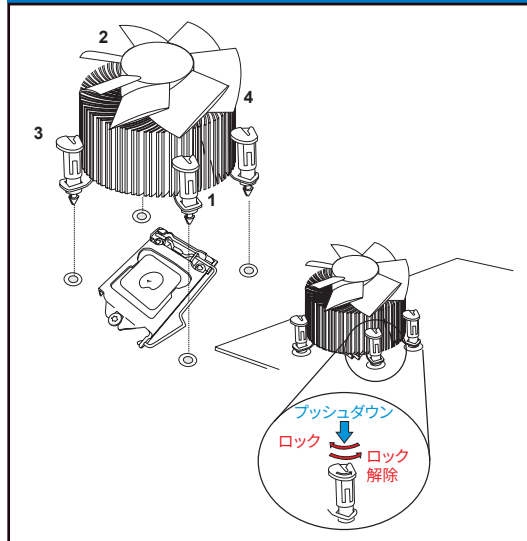

フロント制御パネル (JF1)

	20	19	
接地	○	○	NMI
X	○	○	X
電源 LED	○	○	Vcc
HDD LED	○	○	Vcc
NIC1 LED	○	○	Vcc
NIC2 LED	○	○	Vcc
OH/ファン障害LED	○	○	Vcc
電源障害LED	○	○	Vcc
接地	○	○	#3~4} リセットボタン
接地	○	○	#1~2} 電源ボタン
	2	1	

	20	19	
Ground	○	○	NMI
X	○	○	X
Power LED	○	○	Vcc
HDD LED	○	○	Vcc
NIC1 LED	○	○	Vcc
NIC2 LED	○	○	Vcc
OH/Fan Fail LED	○	○	Vcc
Power Fail LED	○	○	Vcc
Ground	○	○	#3~4} Reset Button
Ground	○	○	#1~2} Power Button
	2	1	

背面パネルI/Oコネクタ

A. DisplayPort 1.4	F. USB3: USB 3.2 Gen1 (タイプA)	K. 2.5Gb LAN ポート2
B. HDMIポート2.0a	G. USB2: USB 3.2 Gen1 (タイプA)	L. USB9: USB 3.2 Gen2 (タイプA)
C. VGAポート (IPMI, X12SCA-Fのみ)	H. 1Gb LAN ポート1	M. USB8: USB 3.2 Gen2 (タイプA)
D. Digital Video Interface (DVI-D)	I. USB7: USB 3.2 Gen2 (タイプA)	N. センター/LFE出力
E. 専用IPMI LANポート (X12SCA-Fのみ)	J. USB6: USB 3.2 Gen2 (タイプC)	O. サラウンド出力
		P. S/PDIF Out
		Q. ライン入力
		R. ライン出力
		S. マイク入力
		T. UIDスイッチ (X12SCA-Fのみ)

메인보드 레이아웃 및 특징

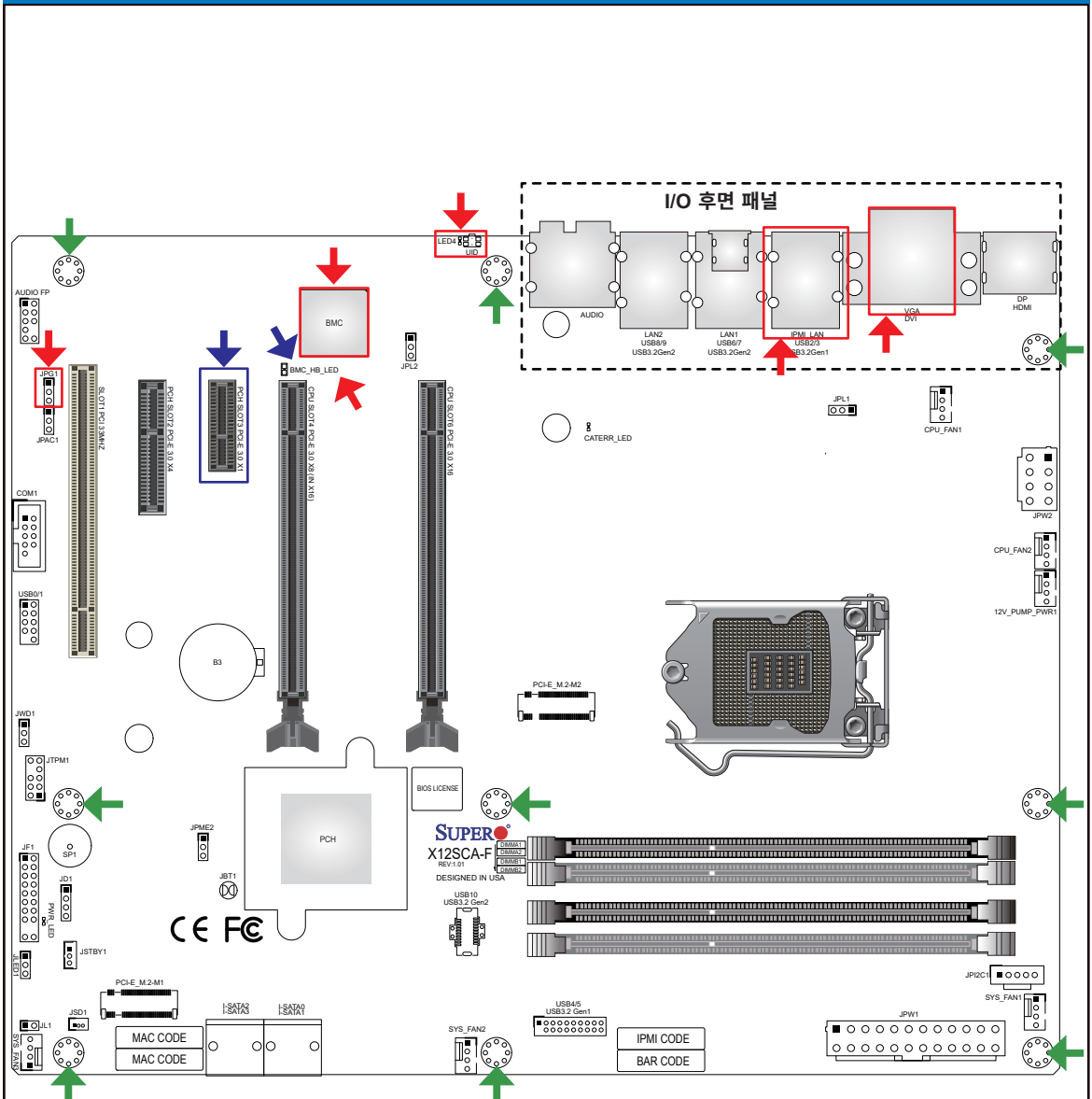

- ➔ = 마운팅홀
- ➔ = X12SAE 전용
- ➔ = X12SCA-F 전용

내용물

- Supermicro 마더보드 1개
- SATA 케이블 4개
- I/O 실드 1개
- 빠른 참조 가이드 1개

점퍼 및 커넥터

점퍼		
점퍼	설명	기본값
JBT1	CMOS 지우기(온보드)	CMOS를 지우는 짧은 패드
JD1	스피커 버저 헤더	핀 1~4: 외부 스피커 핀 3~4: 버저
JPAC1	오디오 사용	핀 1-2(사용)
JPG1	VGA 사용(X12SCA-F 전용)	핀 1-2(사용)
JPL1/2	LAN1/LAN2 사용/사용 안 함	핀 1-2(사용)
JPME2	Intel ME 제조 모드	핀 1-2(일반)
JWD1	Watch Dog 기능 활성화	핀 1-2(RST)

커넥터	
커넥터	설명
12V_PUMP_PWR1	CPU 수냉 펌프용 12V 4핀 전원 커넥터
오디오	고음질 오디오 포트(후면 패널)
AUDIO FP	전면 패널 오디오 헤더
B3	온보드 배터리
COM1	COM 헤더
CPU_FAN 1 ~ CPU_FAN 2	CPU 팬 헤더
CPU SLOT4 PCI-E 3.0 x8(INx16)	PCIe 3.0 x16 슬롯(PCIe 3.0 x8 링크)
CPU SLOT6 PCI-E 3.0 x16	PCIe 3.0 x16 슬롯(PCIe 3.0 x16 링크) 또는 PCIe 3.0 x8(CPU Slot4가 채워진 경우)
DP/HDMI	DisplayPort 커넥터/고해상도 멀티미디어 인터페이스(HDMI)
DVI	디지털 비디오 인터페이스(DVI-D)
I-SATA0~3	Intel 시리얼 ATA(SATA 3.0) 포트 0~3(6Gb/초)
IPMI_LAN	전용 IPMI LAN 포트(X12SCA-F 전용)
JF1	전면 제어 패널 헤더
JL1	세시 침입 헤더
JLED1	3핀 전원 LED 헤더
JPI2C1	전원 공급장치 SMBus I2C 헤더
JPW1	24핀 ATX 주전원 커넥터(필수)
JPW2	+12V 8핀 CPU 전원 커넥터(필수)
JSD1	SATA DOM(디스크-온-모듈) 전원 커넥터
JSTBY1	대기 전력 헤더(5V 대기 헤더)
JTPM1	신뢰할 수 있는 플랫폼 모듈(TPM) 헤더 (TPM 2.0지원)
LAN1/2	LAN1: 1Gb/LAN2: 2.5Gb
PCH SLOT2 PCI-E 3.0 x4	PCIe 3.0 x4 슬롯
PCH SLOT3 PCI-E 3.0 x1	PCIe 3.0 x1 슬롯(X12SAE 전용)
PCI-E_M.2-M1, M2	PCIe M.2 커넥터 1 및 2(PCIe 3.0 x4 링크), 고속 NVMe SSD용 소형 폼 팩터 장치 및 기타 휴대용 장치
SLOT1 PCI 33MHz	PCI 슬롯, 32비트/33MHZ(5V 단일 전압 포함)
SP1	내부 스피커/버저
SYS_FAN1 ~ SYS_FAN3	시스템 팬 헤더
UID	장치 식별자(UID) 스위치(X12SCA-F 전용)
USB0/1	전면 액세스 USB 2.0 헤더
USB2/3	후면 패널 USB 3.2 Gen 1 포트(타입 A)
USB4/5	전면 액세스 USB 3.2 Gen1 헤더
USB6/7	후면 패널 USB 3.2 Gen 2 포트(USB6: 타입 C, USB7: 타입 A)
USB8/9	후면 패널 USB 3.2 Gen 2 포트(타입 A)
USB10	전면 패널 액세스 가능 USB 3.2 Gen 2 20핀 커넥터
VGA	VGA 포트(X12SCA-F, IPMI 전용)

연락처 정보

- www.supermicro.com(이메일: support@supermicro.com)
- 사용 설명서: <http://www.supermicro.com/support/manuals>
- 드라이버 & 유틸리티: <https://www.supermicro.com/wftp/driver/>
- 안전: http://www.supermicro.com/about/policies/safety_information.cfm

LED 표시등

LED 표시등

LED	설명	색/상태
BMC_HB_LED	X12SCA-F: BMC 하트비트 LED X12SAE: 대기 전원 LED	X12SCA-F: 녹색으로 깜박임(정상) X12SAE: 녹색으로 켜짐(대기 전원 켜짐)
CATERR_LED	치명적인 오류 LED	주황색으로 켜짐: 시스템 CATERR
LED4	UID LED(X12SCA-F, IPMI 전용)	파란색으로 켜짐: 장치 식별됨
PWR_LED	온보드 전원 LED	녹색으로 켜짐: 전원 켜짐

CPU 및 메모리 지원

X12SAE/X12SCA-F 메인보드는 단일 Intel® Xeon® W-1200 시리즈, 10세대 Core™ i9/i7/i5/i3 시리즈 프로세서와, 4개의 288핀 메모리 슬롯에서 최대 128GB의 언버퍼드(UDIMM) ECC/비-ECC 메모리, 최대 2933MHz(2DPC) 속도를 지원합니다. 유형과 크기가 동일한 메모리 모듈 한 쌍으로 DIMM 슬롯을 채우면 메모리가 인터리브되어 메모리 성능이 향상됩니다.

- 참고:** 1) 메모리 최적화를 위해 반드시 Supermicro의 인증을 받은 DIMM 모듈을 사용해야 합니다. 최신 메모리 업데이트는 당사 웹사이트 <http://www.supermicro.com/products/motherboard>를 참조하십시오.
- 2) 전원 코드는 반드시 마지막에 연결하고 하드웨어 구성품을 추가, 제거 또는 변경하기 전에는 반드시 전원 코드를 뽑아야 합니다.
- 3) 이 메인보드에서 지원하는 10th Core-i 시리즈 프로세서는 제한됩니다. 자세한 내용은 Supermicro 및 Intel 웹사이트를 참조하십시오.
- 4) Intel W-1200 시리즈 프로세서는 레거시 VBIOS가 아닌 UEFI GOP 드라이버를 통해 IGFX(Intel Graphics)를 지원합니다.

DIMM 메모리 설치



CPU 방향

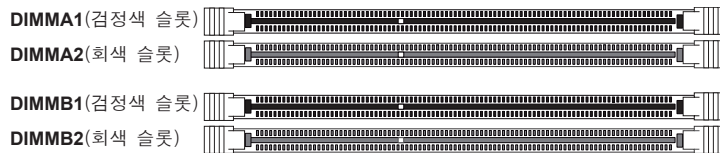

메모리 채우기 가이드라인

메모리 모듈을 설치할 때 DIMM 슬롯을 다음 순서로 채워야 합니다. DIMMA2, DIMMB2, 그 다음에 DIMMA1, DIMMB1.

- 항상 동일한 크기, 유형, 속도의 DDR4 DIMM 모듈을 사용하십시오.
- 혼합된 DIMM 속도를 설치해도 됩니다. 그러나 모든 DIMM가 가장 느린 DIMM 속도로 작동하게 됩니다.

권장 채우기(균형)

DIMMA1	DIMMB1	DIMMA2	DIMMB2	총 시스템 메모리
		2GB DIMM	2GB DIMM	4GB
2GB DIMM	2GB DIMM	2GB DIMM	2GB DIMM	8GB
		4GB DIMM	4GB DIMM	8GB
4GB DIMM	4GB DIMM	4GB DIMM	4GB DIMM	16GB
		8GB DIMM	8GB DIMM	16GB
8GB DIMM	8GB DIMM	8GB DIMM	8GB DIMM	32GB
		16GB DIMM	16GB DIMM	32GB
16GB DIMM	16GB DIMM	16GB DIMM	16GB DIMM	64GB
		32GB DIMM	32GB DIMM	64GB
32GB DIMM	32GB DIMM	32GB DIMM	32GB DIMM	128GB

참고

- 이 간편 설명서의 그림들은 예시로만 사용됩니다. 실제 부품은 안내서에 표시된 도면과 동일하지 않을 수 있습니다.
- 점퍼, 커넥터, LED 표시등, 메모리 지원 및 CPU /메인보드 설치 지침에 대한 자세한 내용은 사용 설명서의 2장을 참조하십시오.

CPU 설치

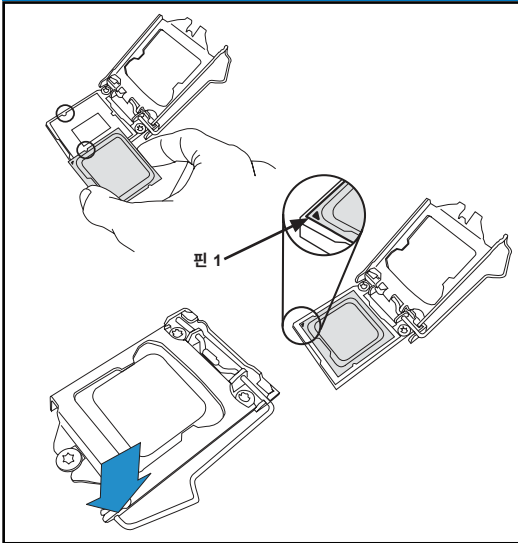

방열판 설치

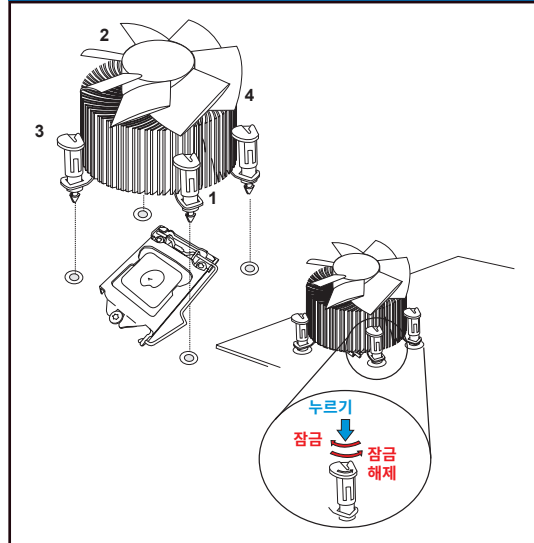

전면 제어 패널(JF1)

	20	19			20	19	
접지	○	○	NMI		○	○	NMI
X	○	○	X		○	○	X
전원 LED	○	○	Vcc		○	○	Vcc
HDD LED	○	○	Vcc		○	○	Vcc
NIC1 LED	○	○	Vcc		○	○	Vcc
NIC2 LED	○	○	Vcc		○	○	Vcc
OH/팬 고장 LED	○	○	Vcc		○	○	Vcc
전원 고장 LED	○	○	Vcc		○	○	Vcc
접지	○	○	#3~4 리셋 버튼		○	○	#3~4 Reset Button
접지	○	○	#1~2 전원 버튼		○	○	#1~2 Power Button
	2	1			2	1	

후면 패널 I/O 커넥터

A. DisplayPort 1.4	F. USB3: USB 3.2 Gen1(타입 A)	K. 2.5Gb LAN 포트 2
B. HDMI 포트 2.0a	G. USB2: USB 3.2 Gen1(타입 A)	L. USB9: USB 3.2 Gen2(타입 A)
C. VGA 포트(IPMI, X12SCA-F 전용)	H. 1Gb LAN 포트 1	M. USB8: USB 3.2 Gen2(타입 A)
D. 디지털 비디오 인터페이스(DVI-D)	I. USB7: USB 3.2 Gen2(타입 A)	N. 중앙/LFE 출력
E. 전용 IPMI LAN 포트 (X12SCA-F 전용)	J. USB6: USB 3.2 Gen2(타입 C)	O. 서라운드 출력
		P. S/PDIF 출력
		Q. 라인 입력
		R. 라인 출력
		S. 마이크 입력
		T. UID 스위치(X12SCA-F 전용)

MNL-2263-QRG-10b

Notes

Notes

Notes

