



X12SPA-TF

ENGLISH

繁體中文

简体中文

日本語

한국어

QUICK REFERENCE GUIDE

Revision 1.1

Standardized Warning Statements

Motherboards

About Standardized Warning Statements

The following statements are industry standard warnings, provided to warn the user of situations where bodily injury might occur. Should you have questions or experience difficulty, contact Supermicro's Technical Support Department for assistance. Only certified technicians should attempt to install or configure components.

Read this section in its entirety before installing or configuring components in the Supermicro chassis.



WARNING: This product can expose you to chemicals including lead, known to the State of California to cause cancer and birth defects or other reproductive harm. For more information, go to www.P65Warnings.ca.gov.

Battery Handling



Warning!

There is a danger of explosion if the battery is replaced incorrectly. Replace the battery only with the same or an equivalent type recommended by the manufacturer. Dispose of used batteries according to the manufacturer's instructions.

警告

電池更換不當會有爆炸危險。請使用製造商建議之相同或功能相當的電池更換原有電池。請按照製造商的說明指示處理廢棄舊電池。

警告

電池更換不當會有爆炸危險。請只使用同類電池或製造商推薦的功能相當的電池更換原有電池。請按製造商的說明處理廢舊電池。

電池の取り扱い

電池交換が正しく行われなかった場合、破裂の危険性があります。交換する電池はメーカーが推奨する型、または同等のものを使用下さい。使用済電池は製造元の指示に従って処分して下さい。

경고!

배터리가 올바르게 교체되지 않으면 폭발의 위험이 있습니다. 기존 배터리와 동일하거나 제조사에서 권장하는 동등한 종류의 배터리로만 교체해야 합니다. 제조사의 안내에 따라 사용된 배터리를 처리하여 주십시오.

هناك خطر من انفجار في حالة استبدال البطارية بطريقة غير صحيحة فعليك استبدال البطارية فقط بنفس النوع أو ما يعادلها كما أوصت به الشركة المصنعة تخلص من البطاريات المستعملة وفقا لتعليمات الشركة الصانعة

限用物質含有情況標示聲明書

Declaration of the Presence Condition of the Restricted Substances Marking

設備名稱：主機板 / Motherboard Equipment name						
型號（型式）：X12SPA-TF Type designation (Type)						
單元 Unit	限用物質及其化學符號 Restricted substances and its chemical symbols					
	鉛Lead (Pb)	汞Mercury (Hg)	鎘Cadmium (Cd)	六價鉻 Hexavalent chromium (Cr ⁺⁶)	多溴聯苯 Polybrominated biphenyls (PBB)	多溴二苯醚 Polybrominated diphenyl ethers (PBDE)
主機板 (Motherboard)	—	○	○	○	○	○
備考1. “超出0.1 wt %”及“超出0.01 wt %”係指限用物質之百分比含量超出百分比含量基準值。 Note 1 : “Exceeding 0.1 wt %” and “exceeding 0.01 wt %” indicate that the percentage content of the restricted substance exceeds the reference percentage value of presence condition.						
備考2. “○”係指該項限用物質之百分比含量未超出百分比含量基準值。 Note 2 : “○” indicates that the percentage content of the restricted substance does not exceed the percentage of reference value of presence.						
備考3. “—”係指該項限用物質為排除項目。 Note 3 : The “—” indicates that the restricted substance corresponds to the exemption.						

AMI BIOS POST Codes

About AMI BIOS POST Codes

The table below lists some of AMI BIOS POST codes for this motherboard. For more information, refer to https://www.supermicro.com/manuals/other/AMI_AptioV_BIOS_POST_Codes_for_SM_Motherboards.pdf.

Code	Description
0x32	CPU post-memory initialization is started
0x55	No Memory detected or memory failed
0x63	CPU DXE initialization is started
0x69	North Bridge DXE initialization is started
0x70	South Bridge DXE initialization is started
0x92	PCI Bus initialization is started
0x99	Super IO Initialization
0x9A	USB initialization is started
0xA0	IDE initialization is started
0xA9	Boot into BIOS setup menu
0xAE	Legacy Boot event
0xB2	Legacy Option ROM Initialization
0xB4	USB hot plug
0xD6	No console output devices are found
0xD7	No console input devices are found
0xF2	Recovery process started
0xF9	Recovery capsule is not found

M.2 Device Installation

This motherboard has four M.2 M-key sockets that support M.2 2260/2280/22110 modules. One standoff and a screw are pre-installed into the position of each 2280 mounting hole; one standoff is pre-installed into the position of each 22110 mounting hole.

Note 1: It is strongly recommended that you install a heatsink on the M.2 device or use a M.2 device with a built-in heatsink.

Note 2: Be sure to install the M.2 device(s) prior to placing the motherboard into a chassis.

2280/22110 M.2 Device Installation

1. Locate the pre-installed screw (in the position of 2280 mounting hole). Remove the screw and set it aside.

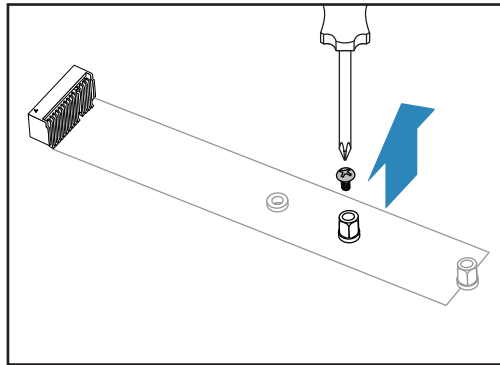

2. Insert the M.2 device into the M.2 socket at a 30 degree and press it down.

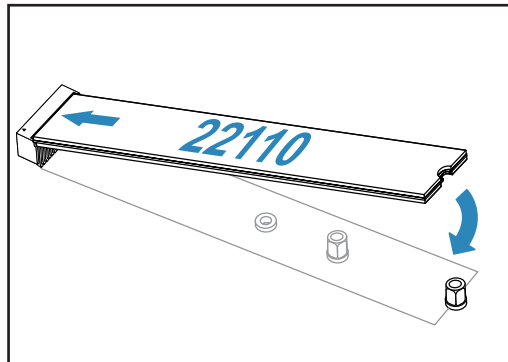
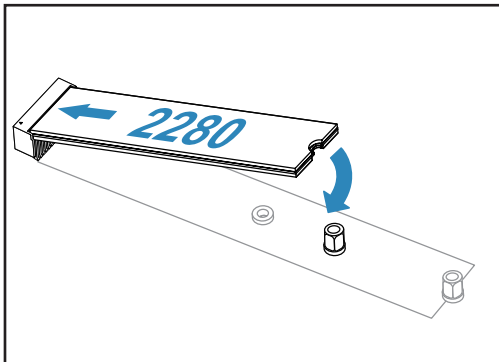

3. Tighten the screw to secure the M.2 device into place. Do not overtighten so as to avoid damaging the M.2 device.

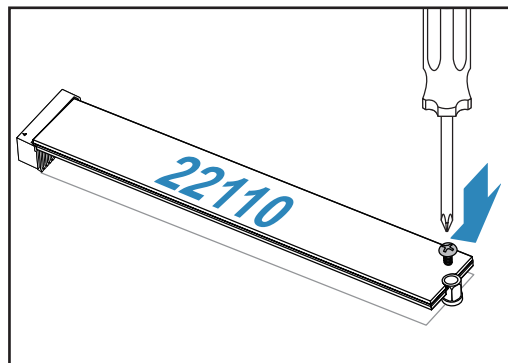
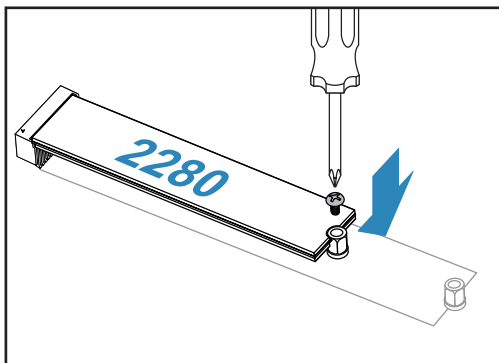

2260 M.2 Device Installation

1. Locate the pre-installed standoff and screw (in the position of 2280 mounting hole). Remove the screw and set it aside.

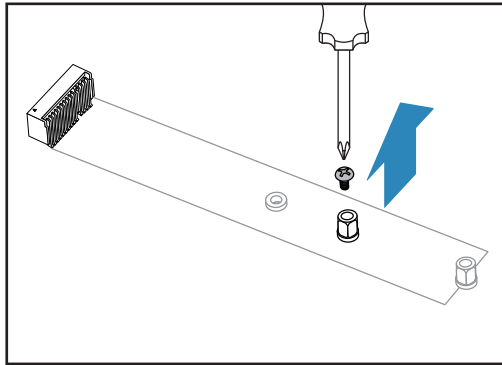

2. Using a hex socket screwdriver, remove and then re-install the standoff to the position of 2260 mounting hole.

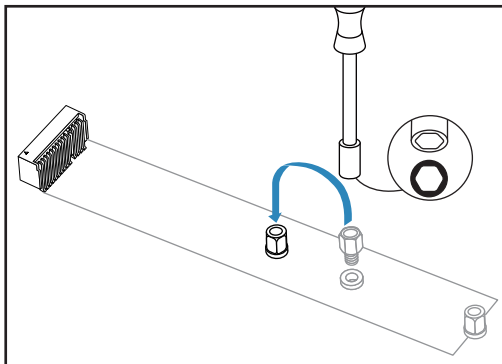

3. Insert the M.2 device into the M.2 socket at a 30 degree angle and press it down.

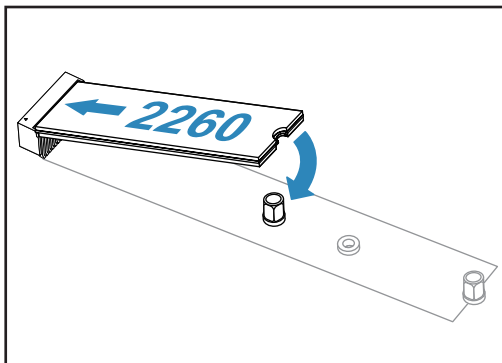

4. Tighten the screw to secure the M.2 device into place. Do not overtighten so as to avoid damaging the M.2 device.

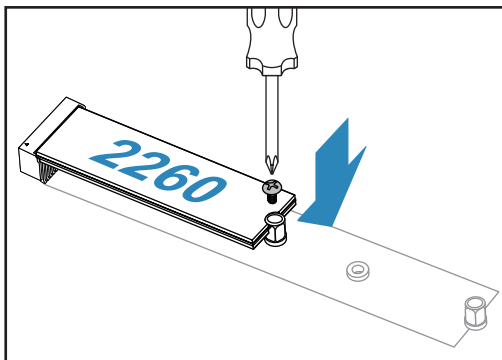

Notes

PACKAGE CONTENTS

- One Supermicro Motherboard
- Six SATA Cables
- One I/O Shield
- One Quick Reference Guide
- One GPU to CPU Power Cable
- One CPU Carrier

Jumpers and Connectors

Jumpers		
Jumper	Description	Default
J9701, J9702	Debug Mode	Pins 1-2 (Normal)
JBT1	Clear CMOS (Onboard)	Short Pads to Clear CMOS
JP4	USB11/12 Disable	Pins 1-2 (Normal)
JP5	USB4 Disable	Pins 1-2 (Normal)
JPAC1	HD Audio Enable/Disable	Pins 1-2 (Enabled)
JPG1	VGA Enable/Disable	Pins 1-2 (Enabled)
JPL1, JPL2	LAN1/LAN2 Enable/Disable	Pins 1-2 (Enabled)
JPME2	Intel Manufacturing Mode	Pins 1-2 (Normal)
JPUSB1	USB7/8 Wake Up	Pins 1-2 (Enabled)
JWD1	Watch Dog Function Enable	Pins 1-2 (Reset)

Connectors	
Connector	Description
12V_PUMP_PWR1	12V 4-pin Power Connector for CPU Liquid Cooling Pump
AUDIO FP	Front Panel Audio Header
BATTERY	Onboard Battery
COM1, COM2	COM1: COM Port (Back Panel). COM2: COM Header
CPU SLOT1/3/5/7	PCIe 4.0 x16 Slots * SLOT1 will be disabled when either M.2-C01 or M.2-C02 is in use. * SLOT1 will change to PCIe x8 when M.2-C03 or/and M.2-C04 are in use. * SLOT3/5/7 will change to PCIe x8 when SLOT2/4/6 is in use respectively.
CPU SLOT2/4/6	PCIe 4.0 x8 Slots (IN x16)
FAN1 – FAN6	CPU Fan Headers
FAN A – FAN D	System Fan Headers
HD AUDIO	Back Panel High Definition Audio Ports
I-SATA0 – I-SATA7	Intel Serial ATA (SATA 3.0) Ports 0–7 (6Gb/second)
I-SGPIO1, I-SGPIO2	Serial General Purpose I/O Headers
IPMI_LAN	Dedicated IPMI LAN Port
JD1	Power LED / Speaker Header (Pins 1-3: Power LED, Pins 4-7: Speaker)
JF1	Front Control Panel Header
JIPMB1	4-pin External I ² C Header (for an IPMI card)
JL1	Chassis Intrusion Header
JOH1-OH	Overheat LED Header
JPI2C1	Power Supply SMBus I ² C Header
JPWR1/3/4	+12V 8-pin CPU Power Connectors (Required)
JPWR2	24-pin ATX Main Power Connector (Required)
JRK1	Intel VROC RAID Key Header (Note: A VROC hardware key is required to enable an M.2 RAID card.)
JSD1, JSD2	SATA DOM (Disk-On-Module) Power Connectors
JSPDIF_OUT	Sony/Philips Digital Interface (S/PDIF) Out Header
JSTBY1	Standby Power Header (5V)
JTPM1	Trusted Platform Module (TPM)/Port 80 Header
LAN1, LAN2	LAN1: RJ45 1GbE LAN Port. LAN2: RJ45 10GbE LAN Port
M.2-C01 – M.2-C04	PCIe 4.0 x4 M.2 M-key Sockets (Support RAID 0/1/5/10) * Populating M.2-C03 or/and M.2-C04 sockets might have a performance impact on CPU SLOT1. * Small form factor devices and other portable devices for high speed NVMe SSDs
MH14_SRW4 – MH14_SRW7	M.2 Mounting Holes
SP1	Internal Speaker/Buzzer
UID-SW	Unit Identifier (UID) Switch
USB0/1	Front Access USB 2.0 Header
USB2/3	Front Access USB 3.2 Gen. 1 Header
USB4	Back Panel USB 3.2 Gen. 2x2 Port
USB5, USB6, USB7, USB8	Back Panel USB 3.2 Gen. 1 Ports
USB9, USB10	Back Panel USB 2.0 Ports
USB11	Front Access USB 3.2 Gen. 2 Port
USB12	Front Access USB 3.2 Gen. 2 Header
VGA	VGA Port

CONTACT INFORMATION

- www.supermicro.com (Email: support@supermicro.com)
- Manuals: <http://www.supermicro.com/support/manuals>
- Drivers & Utilities: <https://www.supermicro.com/wdl/driver/>
- Safety: http://www.supermicro.com/about/policies/safety_information.cfm

LED Indicators

LED Indicators		
LED	Description	Color/State
LE3, LE4, LE5, LE6	M.2 LEDs for M.2-C04/M.2-C03/M.2-C02/M.2-C01	Blinking Green: Device Working
LEDBMC	BMC Heartbeat LED	Blinking Green: BMC Normal
LEDPWR	Onboard Power LED	Solid Green: Power On
UID-LED	Unit Identifier (UID) LED	Blue On: Unit Identified

CPU & Memory Support

The X12SPA-TF motherboard supports a single 3rd Generation Intel Xeon® Scalable processor/Intel Xeon W-33xx series processor. Memory supports up to 1TB of ECC RDIMM, 4TB of 3DS RDIMM, 2TB of LRDIMM, and 4TB of 3DS LRDIMM with speeds of up to 3200 MHz (2DPC) in 16 DDR4 (288-pin) SMD DIMM slots. Populating these DIMM slots with a pair of memory modules of the same type and size will result in interleaved memory, which will improve memory performance. 1DPC and 2DPC are recommended for memory installation. Only selected 3rd Gen. Intel Xeon Scalable-SP processors support Intel Optane Persistent Memory (PMem) 200 Series.

Notes: 1) For memory optimization, use only DIMM modules that have been validated by Supermicro. For the latest memory updates, please refer to our website at <http://www.supermicro.com/products/motherboard>.

2) Always connect the power cord last, and always remove it before adding, removing, or changing any hardware components.

DIMM Memory Installation

 Towards the CPU

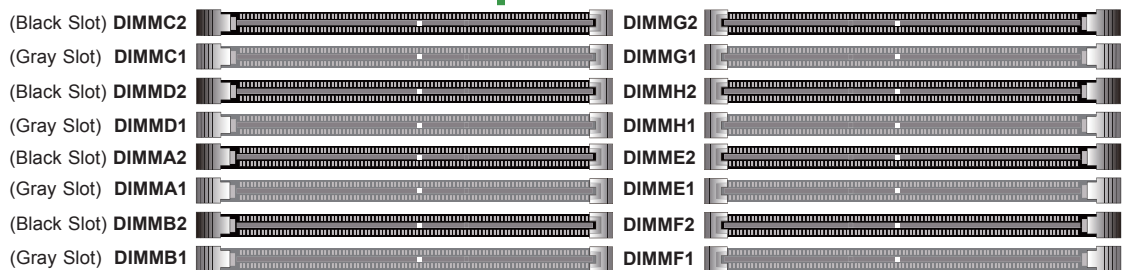

Memory Population Guidelines

- Always use DDR4 DIMM modules of the same size, type, and speed.
- Mixed DIMM speeds can be installed. However, all DIMMs will run at the speed of the slowest DIMM.
- In a given channel, the black slot can be enabled only when the gray slot is populated first.

Memory Population Table (w/ 16 Slots)

When one CPU is used:	Memory Population Sequence
1 CPU & 1 DIMM	CPU1: P1-DIMMA1
1 CPU & 2 DIMMs	CPU1: P1-DIMMA1/P1-DIMME1
1 CPU & 3 DIMMs*	CPU1: P1-DIMMA1/P1-DIMME1/P1-DIMMC1
1 CPU & 4 DIMMs	CPU1: P1-DIMMA1/P1-DIMME1/P1-DIMMC1/P1-DIMMG1
1 CPU & 5 DIMMs*	CPU1: P1-DIMMA1/P1-DIMMB1/P1-DIMME1/P1-DIMMC1/P1-DIMMG1
1 CPU & 6 DIMM	CPU1: P1-DIMMA1/P1-DIMMB1/P1-DIMME1/P1-DIMMF1/P1-DIMMC1/P1-DIMMG1
1 CPU & 7 DIMMs*	CPU1: P1-DIMMA1/P1-DIMMB1/P1-DIMMD1/P1-DIMME1/P1-DIMMF1/P1-DIMMC1/P1-DIMMG1
1 CPU & 8 DIMMs	CPU1: P1-DIMMA1/P1-DIMMB1/P1-DIMMD1/P1-DIMME1/P1-DIMMF1/P1-DIMMC1/P1-DIMMH1
1 CPU & 9 DIMMs*	CPU1: P1-DIMMA1/P1-DIMMA2/P1-DIMMB1/P1-DIMMC1/P1-DIMMD1/P1-DIMME1/P1-DIMMF1/P1-DIMMG1/P1-DIMMH1
1 CPU & 10 DIMMs	CPU1: P1-DIMMA1/P1-DIMMA2/P1-DIMMB1/P1-DIMMC1/P1-DIMMD1/P1-DIMME1/P1-DIMME2/P1-DIMMF1/P1-DIMMG1/P1-DIMMH1
1 CPU & 11 DIMMs*	CPU1: P1-DIMMA1/P1-DIMMA2/P1-DIMMB1/P1-DIMMC1/P1-DIMMC2/P1-DIMMD1/P1-DIMME1/P1-DIMME2/P1-DIMMF1/P1-DIMMG1/P1-DIMMH1
1 CPU & 12 DIMMs	CPU1: P1-DIMMA1/P1-DIMMA2/P1-DIMMB1/P1-DIMMC1/P1-DIMMC2/P1-DIMMD1/P1-DIMME1/P1-DIMME2/P1-DIMMF1/P1-DIMMG1/P1-DIMMG2/P1-DIMMH1
1 CPU & 13 DIMMs*	CPU1: P1-DIMMA1/P1-DIMMA2/P1-DIMMB1/P1-DIMMB2/P1-DIMMC1/P1-DIMMC2/P1-DIMMD1/P1-DIMME1/P1-DIMME2/P1-DIMMF1/P1-DIMMF2/P1-DIMMG1/P1-DIMMH1
1 CPU & 14 DIMM	CPU1: P1-DIMMA1/P1-DIMMA2/P1-DIMMB1/P1-DIMMB2/P1-DIMMC1/P1-DIMMC2/P1-DIMMD1/P1-DIMME1/P1-DIMME2/P1-DIMMF1/P1-DIMMF2/P1-DIMMG1/P1-DIMMG2/P1-DIMMH1
1 CPU & 15 DIMMs*	CPU1: P1-DIMMA1/P1-DIMMA2/P1-DIMMB1/P1-DIMMB2/P1-DIMMC1/P1-DIMMC2/P1-DIMMD1/P1-DIMMD2/P1-DIMME1/P1-DIMME2/P1-DIMMF1/P1-DIMMF2/P1-DIMMG1/P1-DIMMG2/P1-DIMMH1
1 CPU & 16 DIMMs	CPU1: P1-DIMMA1/P1-DIMMA2/P1-DIMMB1/P1-DIMMB2/P1-DIMMC1/P1-DIMMC2/P1-DIMMD1/P1-DIMMD2/P1-DIMME1/P1-DIMME2/P1-DIMMF1/P1-DIMMF2/P1-DIMMG1/P1-DIMMG2/P1-DIMMH1/P1-DIMMH2

Note: *Unbalanced configuration (not recommended due to decreased performance)

NOTES

- Graphics shown in this quick reference guide are for illustration only. Your components may or may not look exactly the same as drawings shown in this guide.
- Refer to Chapter 2 of the User Manual for detailed information on jumpers, connectors, LED indicators, memory support and CPU/motherboard installation instructions.

CPU and PHM Installation

- Using Pin 1 as a guide, carefully align the CPU keys (A & B) on the processor against the CPU keys on the carrier (a & b) as shown in the drawing below. Once they are properly aligned, carefully place one end of the processor into the latch marked 1 on the carrier, and place the other end of processor into the latch marked 2.
- Carefully place the corner marked "a" on the processor carrier assembly into the corner of the heatsink marked "A". Repeat the same step to place the corners marked "b", "c", "d" on the processor carrier assembly into the corners of the heatsink marked "B", "C", "D" making sure that all plastic clips are properly attached to the heatsink.

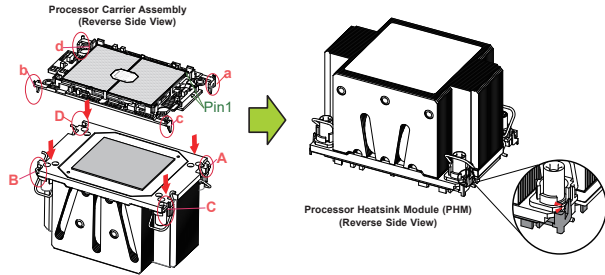
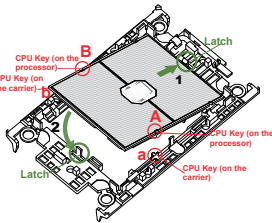
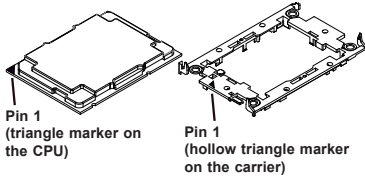

- Gently place the Processor Heatsink Module (PHM) on top of the CPU socket, making sure that each PEEK nut is properly attached to its corresponding threaded fastener.

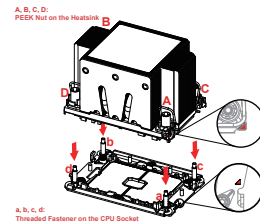

Front Control Panel (JF1)

	1	2	
Power Button	PWR	○	Ground
Reset Button	Reset	○	Ground
	P3V3	○	Power Fail LED
UID-LED	○	○	OH/Fan Fail LED
P3V3_STBY	○	○	NIC2 Active LED
P3V3_STBY	○	○	NIC1 Active LED
P3V3_STBY_UID SW	○	○	HDD LED
P3V3	○	○	PWR LED
X	○	○	X
SW_NMI_N	○	○	Ground

19 20

Back Panel I/O Connectors

1. LAN1: RJ45 1Gb LAN Port	6. Dedicated IPMI LAN Port	11. USB6: USB 3.2 Gen. 1 Port	16. Line In
2. USB9: USB 2.0 Port	7. USB7: USB 3.2 Gen. 1 Port	12. USB4: USB 3.2 Gen. 2x2 Port	17. Line Out
3. USB10: USB 2.0 Port	8. USB8: USB 3.2 Gen. 1 Port	13. Center/LFE Out	18. Mic In
4. COM1 Port	9. LAN2: RJ45 10Gb LAN Port	14. Surround Out	19. UID Switch
5. VGA Port	10. USB5: USB 3.2 Gen. 1 Port	15. S/PDIF Out	

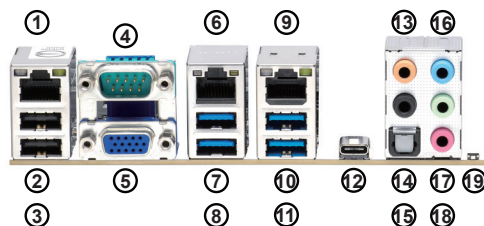

單一主機板包裝盒內容清單

- Supermicro 主機板 x1
- SATA 訊號線 x6
- 後擋板 x1
- 快速參考指南 x1
- GPU 轉 CPU 電源線 x1
- CPU 處理器載具 x1

跳線器/連接埠

跳線器 (Jumper)		
跳線器	說明	預設值
J9701, J9702	偵錯模式	針腳 1-2 (正常)
JBT1	CMOS 組態資料清除 (內建)	設為短路清除 CMOS 資料
JP4	停用 USB11/12 連接埠	針腳 1-2 (正常)
JP5	停用 USB4 連接埠	針腳 1-2 (正常)
JPAC1	啟用/停用音源	針腳 1-2 (啟用)
JPG1	啟用/停用 VGA	針腳 1-2 (啟用)
JPL1, JPL2	啟用/停用 LAN1/LAN2	針腳 1-2 (啟用)
JPME2	Intel 製造模式	針腳 1-2 (正常)
JPUSB1	USB7/8 喚醒	針腳 1-2 (啟用)
JWD1	啟用系統監控 (Watch Dog) 功能	針腳 1-2 (重設)
連接埠 (Connector)		
連接埠	說明	
12V_PUMP_PWR1	12V 4針腳 水冷幫浦電源插座	
AUDIO FP	前面板音效接頭	
BATTERY	內建電池	
COM1, COM2	COM1 : COM 連接埠 (背板) 。 COM2 : COM 連接埠接頭	
CPU SLOT1/3/5/7	PCIe 4.0 x16 插槽 * 當 M.2-C01 或 M.2-C02 已安裝 SSD 固態硬碟時，SLOT1 將無法使用。 * 當 M.2-C03 或/和 M.2-C04 已安裝 SSD 固態硬碟時，SLOT1 將改以 PCIe x8 運行。 * 當 SLOT2、SLOT4、SLOT6 已安裝硬體裝置時，分別將影響 SLOT3、SLOT5、SLOT7 改以 PCIe x8 運行。	
CPU SLOT2/4/6	PCIe 4.0 x8 插槽 (IN x16)	
FAN1 – FAN6	中央處理器 (CPU) 風扇接頭	
FAN A – FAN D	系統風扇接頭	
HD AUDIO	背板高清晰音效插孔	
I-SATA0 – I-SATA7	Intel 序列 ATA 介面 (SATA 3.0) 連接埠 0-7 (6 Gb/秒)	
I-SGPIO1, I-SGPIO2	序列通用 I/O 傳輸插座	
IPMI_LAN	IPMI 網路連接埠	
JD1	電源指示燈/喇叭接頭 (針腳 1-3 : 電源指示燈，針腳 4-7 : 喇叭)	
JF1	前控制面板接頭	
JIPMB1	4針腳外接 I ² C 接頭 (僅適用於 IPMI)	
JL1	機殼防盜裝置接頭	
JOH1-OH	過熱顯示指示燈接頭	
JPI2C1	電源供應 SMBus I ² C 接頭	
JPWR1/3/4	+12V 8針腳 CPU 電源連接埠 (必備)	
JPWR2	24針腳 ATX 主電源連接埠 (必備)	
JRK1	Intel VROC RAID Key 接頭 (啟用 M.2 RAID 功能需加裝 VROC Hardware Key)	
JSD1, JSD2	SATA DOM (磁碟模組) 電源連接埠	
JSPDIF_OUT	S/PDIF (索尼/飛利浦數位傳輸介面) 輸出接頭	
JSTBY1	待機電源接頭 (5V)	
JTPM1	TPM 信任平台模組 / Port 80 接頭	
LAN1, LAN2	LAN1 : RJ45 1GbE 網路線連接埠。 LAN2 : RJ45 10GbE 網路線連接埠	
M.2-C01 – M.2-C04	PCIe 4.0 x4 M.2 M-key 裝置連接埠 (支援 RAID 0/1/5/10) * 當 M.2-C03 或/和 M.2-C04 已安裝 SSD 固態硬碟時，可能會對 CPU SLOT1 的效能產生影響。 * 適用具高速傳輸 NVMe 介面小尺寸及其他可攜式 M.2 固態硬碟。	
MH14_SRW4 – MH14_SRW7	M.2 裝置安裝孔	
SP1	內建喇叭/蜂鳴器	
UID-SW	單位識別按鈕	
USB0/1	前面板 USB 2.0 規格接頭	
USB2/3	前面板 USB 3.2 Gen. 1 規格接頭	
USB4	背板 USB 3.2 Gen. 2x2 規格連接埠	
USB5, USB6, USB7, USB8	背板 USB 3.2 Gen. 1 規格連接埠	
USB9, USB10	背板 USB 2.0 規格連接埠	
USB11	前面板 USB 3.2 Gen. 2 規格連接埠	
USB12	前面板 USB 3.2 Gen. 2 規格接頭	
VGA	VGA 連接埠	

線上技術支援及下載

- 聯絡我們 (技術支援信箱) : www.supernmicro.com (Email: support@supernmicro.com)
- 產品手冊文件 : <http://www.supernmicro.com/support/manuals>
- 驅動程式及工具程式 : <https://www.supernmicro.com/wdl/driver/>
- 產品安全性須知 : http://www.supernmicro.com/about/policies/safety_information.cfm

LED 指示燈

LED 指示燈		
LED燈	說明	燈號顏色及狀態
LE3, LE4, LE5, LE6	分別代表 M.2-C04/M.2-C03/M.2-C02/M.2-C01 的 M.2 裝置指示燈	綠燈閃爍: M.2 使用中
LEDBMC	BMC 運作指示燈	綠燈閃爍: BMC 正常
LEDPWR	內建電源指示燈	綠燈恆亮: 開啟
UID-LED	單位識別指示燈	藍燈恆亮: 識別中

中央處理器和記憶體支援

主機板 X12SPA-TF 支援單顆第三代 Intel Xeon Scalable/Intel Xeon W-33xx 系列處理器。記憶體容量最高可達 1TB ECC RDIMM、4TB 3DS RDIMM、2TB LRDIMM、4TB 3DS LRDIMM，及支援十六根傳輸頻率最高可達 3200 MHz (2DPC) 288支針腳 SMD 記憶體插槽。欲取得雙通道效能，請安裝成對相同型號與速度的記憶體。記憶體安裝建議使用 1DPC 或 2DPC。僅部分的第三代 Intel Xeon Scalable-SP 系列處理器可支援 Intel Optane Persistent Memory (PMem) 200 Series。

註：1) 請安裝使用本公司所認可的記憶體模組以達記憶體模組最佳化。更多的記憶體模組相關訊息，請參閱本公司網頁 <http://www.supernmicro.com/products/motherboard>。

2) 增加、移除和更換任何硬體元件前，請務必先拔掉電源線。待確實完成所有程序後，再重新連接電源線。

3) ECC 是 Error Correction Code 的縮寫，中譯為「錯誤修正碼」；DDR 為「雙倍速動態隨機存取記憶體」。

記憶體模組 (DIMM) 安裝



此面朝向中央處理器

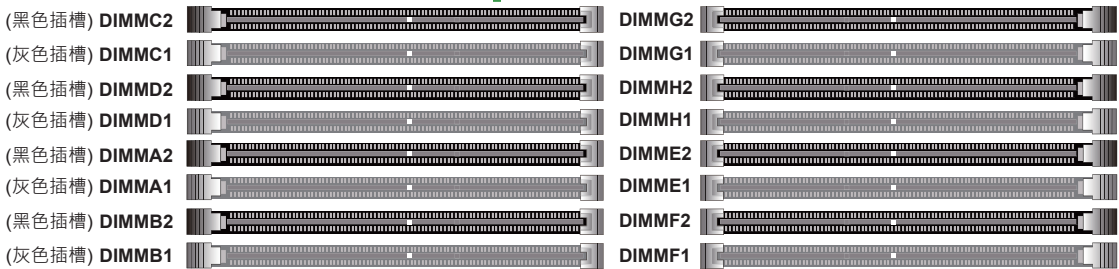

請依照以下說明及表格安裝記憶體模組：

- 請使用相同型號與速度的記憶體 (DDR4)。
- 若混合使用不同速度的記憶體，系統將依較低的記憶體速度執行。
- 安裝記憶體模組時，請先安裝該通道的灰色插槽，黑色插槽才能發揮效能。

記憶體插槽使用順序 (16 根記憶體插槽)	
1 CPU & 1 DIMM	CPU1: P1-DIMMA1
1 CPU & 2 DIMMs	CPU1: P1-DIMMA1/P1-DIMME1
1 CPU & 3 DIMMs*	CPU1: P1-DIMMA1/P1-DIMME1/P1-DIMMC1
1 CPU & 4 DIMMs	CPU1: P1-DIMMA1/P1-DIMME1/P1-DIMMC1/P1-DIMMG1
1 CPU & 5 DIMMs*	CPU1: P1-DIMMA1/P1-DIMMB1/P1-DIMME1/P1-DIMMC1/P1-DIMMG1
1 CPU & 6 DIMM	CPU1: P1-DIMMA1/P1-DIMMB1/P1-DIMME1/P1-DIMMF1/P1-DIMMC1/P1-DIMMG1
1 CPU & 7 DIMMs*	CPU1: P1-DIMMA1/P1-DIMMB1/P1-DIMMD1/P1-DIMME1/P1-DIMMF1/P1-DIMMC1/P1-DIMMG1
1 CPU & 8 DIMMs	CPU1: P1-DIMMA1/P1-DIMMB1/P1-DIMMD1/P1-DIMME1/P1-DIMMF1/P1-DIMMC1/P1-DIMMG1/P1-DIMMH1
1 CPU & 9 DIMMs*	CPU1: P1-DIMMA1/P1-DIMMA2/P1-DIMMB1/P1-DIMMC1/P1-DIMMD1/P1-DIMME1/P1-DIMMF1/P1-DIMMG1/P1-DIMMH1
1 CPU & 10 DIMMs	CPU1: P1-DIMMA1/P1-DIMMA2/P1-DIMMB1/P1-DIMMC1/P1-DIMMD1/P1-DIMME1/P1-DIMME2/P1-DIMMF1/P1-DIMMG1/P1-DIMMH1
1 CPU & 11 DIMMs*	CPU1: P1-DIMMA1/P1-DIMMA2/P1-DIMMB1/P1-DIMMC1/P1-DIMMC2/P1-DIMMD1/P1-DIMME1/P1-DIMME2/P1-DIMMF1/P1-DIMMG1/P1-DIMMH1
1 CPU & 12 DIMMs	CPU1: P1-DIMMA1/P1-DIMMA2/P1-DIMMB1/P1-DIMMC1/P1-DIMMC2/P1-DIMMD1/P1-DIMME1/P1-DIMME2/P1-DIMMF1/P1-DIMMG1/P1-DIMMG2/P1-DIMMH1
1 CPU & 13 DIMMs*	CPU1: P1-DIMMA1/P1-DIMMA2/P1-DIMMB1/P1-DIMMB2/P1-DIMMC1/P1-DIMMC2/P1-DIMMD1/P1-DIMME1/P1-DIMME2/P1-DIMMF1/P1-DIMMF2/P1-DIMMG1/P1-DIMMH1
1 CPU & 14 DIMM	CPU1: P1-DIMMA1/P1-DIMMA2/P1-DIMMB1/P1-DIMMB2/P1-DIMMC1/P1-DIMMC2/P1-DIMMD1/P1-DIMME1/P1-DIMME2/P1-DIMMF1/P1-DIMMF2/P1-DIMMG1/P1-DIMMG2/P1-DIMMH1
1 CPU & 15 DIMMs*	CPU1: P1-DIMMA1/P1-DIMMA2/P1-DIMMB1/P1-DIMMB2/P1-DIMMC1/P1-DIMMC2/P1-DIMMD1/P1-DIMMD2/P1-DIMME1/P1-DIMME2/P1-DIMMF1/P1-DIMMF2/P1-DIMMG1/P1-DIMMG2/P1-DIMMH1
1 CPU & 16 DIMMs	CPU1: P1-DIMMA1/P1-DIMMA2/P1-DIMMB1/P1-DIMMB2/P1-DIMMC1/P1-DIMMC2/P1-DIMMD1/P1-DIMMD2/P1-DIMME1/P1-DIMME2/P1-DIMMF1/P1-DIMMF2/P1-DIMMG1/P1-DIMMG2/P1-DIMMH1/P1-DIMMH2

備註：*不平衡組態 (不建議使用，會降低系統效能)

備註

- 快速參考指南中的圖例僅供安裝及操作說明使用，可能與實際產品外觀不同。
- 更多跳線器/連接埠/指示燈/記憶體/主機板/中央處理器相關安裝資訊，請參閱《SUPERMICRO X12SPA-TF 使用手冊》第二章。

中央處理器與散熱器安裝方式

1 以針腳1為對齊點(參考下圖)，再找出 CPU 缺口(下圖標記 A 及 B)，並將其對齊處理器載具校準點(下圖標記 a 及 b)。小心地將 CPU 的一端插入下圖標記 1 的處理器載具凸榫，再將 CPU 的另一端放入下圖標記 2 的處理器載具凸榫。

2 在已安裝 CPU 的處理器載具上找到塑料安裝卡扣(下圖標記 a、b、c、d)，並將其對齊散熱器上的安裝孔(下圖標記 A、B、C、D)。對應的卡扣與安裝孔對齊後，請小心謹慎地將處理器載具組裝至散熱器上，並確認處理器載具卡扣確實鎖住散熱器。

3 請小心謹慎地將處理器散熱模組 (PHM) 安裝在 CPU 腳座 (CPU Socket) 上，並確認每個散熱器上的塑料螺帽 (PEEK Nut，右圖標記 A、B、C、D) 都已正確連接到其相應的螺柱上(右圖標記 a、b、c、d)。

處理器散熱模組 (PHM) 組裝操作說明

針腳 1 (CPU 上的三角形符號)

針腳 1 (處理器載具上的空心三角形符號)

處理器載具凸榫 (標記 1)

處理器載具凸榫 (標記 2)

CPU 缺口 (標記 B)

處理器載具校準點 (標記 b)

CPU 缺口 (標記 A)

處理器載具校準點 (標記 a)

A、B、C、D: 散熱器上的塑料螺帽 (PEEK Nut)

A、B、C、D: CPU 腳座 (CPU Socket) 上的螺柱

前控制面板配置 (JF1)

電源鍵	電源	1	2	接地	Power Button	PWR	1	2	Ground
重設鍵	重設	1	2	接地	Reset Button	Reset	1	2	Ground
P3V3		1	2	電源故障指示燈	P3V3		1	2	Power Fail LED
單位識別指示燈		1	2	過熱/風扇故障指示燈	UID-LED		1	2	OH/Fan Fail LED
P3V3 待機電源		1	2	網卡2 指示燈	P3V3_STBY		1	2	NIC2 Active LED
P3V3 待機電源		1	2	網卡1 指示燈	P3V3_STBY		1	2	NIC1 Active LED
單位識別按鈕		1	2	硬碟指示燈	P3V3_STBY_UID SW		1	2	HDD LED
P3V3		1	2	電源指示燈	P3V3		1	2	PWR LED
X		1	2	X	X		1	2	X
非可遮蔽中斷		1	2	接地	SW_NMI_N		1	2	Ground
		19	20				19	20	

背板輸出/輸入連接埠

1. LAN1: RJ45 1Gb 網路線連接埠	6. IPMI 網路連接埠	11. USB6: USB 3.2 Gen. 1 規格連接埠	16. 音效輸入
2. USB9: USB 2.0 規格連接埠	7. USB7: USB 3.2 Gen. 1 規格連接埠	12. USB4: USB 3.2 Gen. 2x2 規格連接埠	17. 音效輸出
3. USB10: USB 2.0 規格連接埠	8. USB8: USB 3.2 Gen. 1 規格連接埠	13. 中央/低音聲道輸出	18. 麥克風插孔
4. COM1: COM 序列連接埠	9. LAN2: RJ45 10Gb 網路線連接埠	14. 環繞聲道輸出	19. 單位識別按鈕
5. VGA 連接埠	10. USB5: USB 3.2 Gen. 1 規格連接埠	15. S/PDIF 輸出	

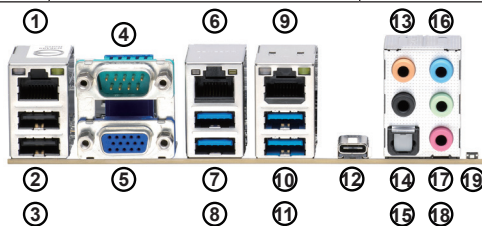

MNL-2273-QRG-110

包装内容

- Supermicro主板 x1
- SATA数据线 x6
- I/O扩展板 x1
- 快速参考指南 x1
- GPU至CPU电源线 x1
- CPU托架 x1

跳线和接口

跳线

跳线	描述说明	默认
J9701, J9702	诊断模式	针脚1-2 (正常)
JBT1	清除CMOS (内建)	短接清除CMOS信息
JP4	禁用USB11/12	针脚1-2 (正常)
JP5	禁用USB4	针脚1-2 (正常)
JPAC1	自动启用/禁用HD	针脚1-2 (启用)
JPG1	启用/禁用VGA	针脚1-2 (启用)
JPL1, JPL2	启用/禁用LAN1/LAN2	针脚1-2 (启用)
JPME2	Intel制造模式	针脚1-2 (正常)
JPUSB1	USB7/8唤醒	针脚1-2 (启用)
JWD1	启用Watchdog功能	针脚1-2 (重置)

接口

接口	描述说明
12V_PUMP_PWR1	CPU液冷泵12V 4针电源接口
AUDIO FP	前面板音频接脚
BATTERY	板载电池
COM1, COM2	COM1: COM端口 (后面板)。COM2: COM 接脚
CPU SLOT1/3/5/7	PCIe 4.0 x16插槽 * 当M.2-C01或M.2-C02插槽使用时, 则SLOT1被禁用。 * 当M.2-C03或M.2-C04插槽使用时, 则SLOT1会降级到PCIe x8模式。 * 当SLOT2, SLOT4, SLOT6使用时, 则SLOT3/5/7只能以PCIe x8带宽运行。
CPU SLOT2/4/6	PCIe 4.0 x8插槽(IN x16)
FAN1 – FAN6	CPU风扇接脚
FAN A – FAN D	系统风扇接脚
HD AUDIO	后面板高清音频端口
I-SATA0 – I-SATA7	Intel串行ATA (SATA 3.0) 端口0-7 (6Gb/秒)
I-SGPIO1, I-SGPIO2	串行通用I/O端口
IPMI LAN	专用IPMI LAN 端口
JD1	电源LED/扬声器接脚 (针脚1-3: 电源LED, 针脚4-7: 扬声器)
JF1	前端控制面板接脚
JIPMB1	4针外部I ² C接脚 (用于IPMI卡)
JL1	机箱侵入接脚
JOH1-OH	过热LED接脚
JPI2C1	电源SMBus I ² C接脚
JPWR1/3/4	+12V 8针CPU电源接口 (必需)
JPWR2	24针ATX主电源接口 (必需)
JRK1	Intel VROC RAID密钥接脚 (备注: 启用M.2 RAID卡时需要VROC硬件密钥。)
JSD1, JSD2	SATA DOM (电子磁盘) 电源接口
JSPDIF_OUT	Sony/Philips数字接口 (S/PDIF) 输出接脚
JSTBY1	备用电源接脚 (5V)
JTPM1	受信任平台模块 (TPM) /端口80接脚
LAN1, LAN2	LAN1: RJ45 1GbE LAN端口。LAN 2: RJ45 10GbE LAN端口
M.2-C01 – M.2-C04	PCIe 4.0 x4 M.2 M-key插座 (支持RAID 0/1/5/10) * 当M.2-C03或M.2-C04插槽使用时, 则会影响到CPU SLOT1带宽性能。 * 用于高速NVMe SSD的小型设备和其他便携式设备。
MH14_SRW4 – MH14_SRW7	M.2安装孔
SP1	内置扬声器/蜂鸣器
UID-SW	单元标识符 (UID) 开关
USB0/1	前端访问USB 2.0接脚
USB2/3	前端访问USB 3.2 Gen. 1接脚
USB4	后面板USB 3.2 Gen. 2x2端口
USB5, USB6, USB7, USB8	后面板USB 3.2 Gen. 1端口
USB9, USB10	后面板USB 2.0 端口
USB11	前端访问USB 3.2 Gen. 2端口
USB12	前端访问USB 3.2 Gen.2接脚
VGA	VGA端口

联系信息

- www.supermicro.com (Email: support@supermicro.com)
- 手册: <http://www.supermicro.com/support/manuals>
- 驱动程序和实用程序: <https://www.supermicro.com/wdl/driver/>
- 安全: http://www.supermicro.com/about/policies/safety_information.cfm

LED 指示器

LED 指示器		
LED	描述说明	颜色/状态
LE3, LE4, LE5, LE6	用于M.2-C04/M.2-C03/M.2-C02/M.2-C01的M.2 LED	绿灯闪烁: 设备工作中
LEDBMC	BMC心跳LED	绿灯闪烁: BMC 正常
LEDPWR	板载电源LED	绿灯常亮: 开机
UID-LED	单元标识符(UID) LED	蓝灯常亮: 设备已识别

CPU和内存支持

X12SPA-TF主板支持单个第3代Intel Xeon Scalable/Intel Xeon W-33xx系列处理器。内存支持高达1TB的ECC RDIMM、4TB的3DS RDIMM、2TB的LRDIMM以及4TB的3DS LRDIMM, 在16个DDR4 (288针) SMD DIMM插槽中的速度高达3200 MHz (2DPC)。在这些DIMM插槽中填充一对相同类型和大小的内存模块将产生交错内存, 这将提高内存性能。内存安装建议使用1DPC和2DPC。只有选定的第三代Intel Xeon可扩展SP处理器支持Intel Optane Persistent Memory (PMem) 200系列。

- 备注:** 1) 要进行内存优化, 请仅使用经Supermicro超微验证的DIMM模块。有关最新的内存更新, 请访问我们的网站<http://www.supermicro.com/products/motherboard>。
- 2) 始终最后连接电源线, 并在添加、移除或更换任何硬件组件之前始终将其断开。

DIMM内存安装



朝向CPU

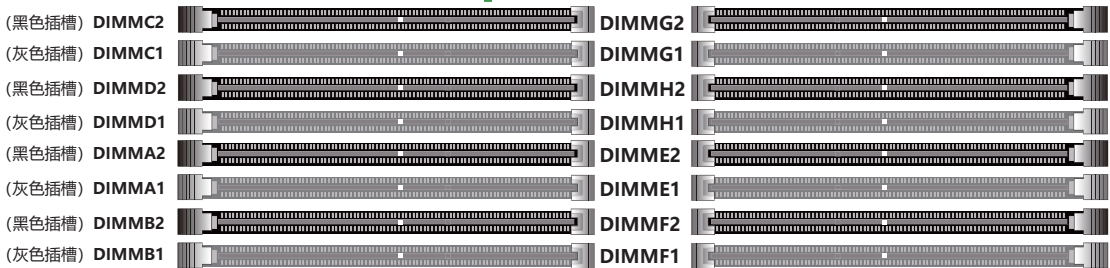

内存填充指南

- 始终使用相同大小、类型和速度的DDR4 DIMM模块。
- 可安装混合DIMM速度。但所有DIMM将会以最慢的DIMM速度运行。
- 在一个给定的通道中, 只有当灰色插槽首先填充时, 黑色插槽才可以启用。

内存填充表 (16个插槽)

当使用1个CPU时:	内存填充序列
1 CPU 和 1 DIMM	CPU1:P1-DIMMA1
1 CPU和2 DIMM	CPU1:P1-DIMMA1/P1-DIMME1
1 CPU和3 DIMM*	CPU1:P1-DIMMA1/P1-DIMME1/P1-DIMMC1
1 CPU和4 DIMM	CPU1:P1-DIMMA1/P1-DIMME1/P1-DIMMC1/P1-DIMMG1
1 CPU和5 DIMM*	CPU1:P1-DIMMA1/P1-DIMMB1/P1-DIMME1/P1-DIMMC1/P1-DIMMG1
1 CPU 和 6 DIMM	CPU1:P1-DIMMA1/P1-DIMMB1/P1-DIMME1/P1-DIMMF1/P1-DIMMC1/P1-DIMMG1
1 CPU 和 7 DIMM*	CPU1:P1-DIMMA1/P1-DIMMB1/P1-DIMMD1/P1-DIMME1/P1-DIMMF1/P1-DIMMC1/P1-DIMMG1
1 CPU 和 8 DIMM	CPU1:P1-DIMMA1/P1-DIMMB1/P1-DIMMD1/P1-DIMME1/P1-DIMMF1/P1-DIMMC1/P1-DIMMG1/P1-DIMMH1
1 CPU 和 9 DIMM*	CPU1:P1-DIMMA1/P1-DIMMA2/P1-DIMMB1/P1-DIMMC1/P1-DIMMD1/P1-DIMME1/P1-DIMMG1/P1-DIMMH1
1 CPU 和 10 DIMM	CPU1:P1-DIMMA1/P1-DIMMA2/P1-DIMMB1/P1-DIMMC1/P1-DIMMD1/P1-DIMME1/P1-DIMME2/P1-DIMMF1/P1-DIMMG1/P1-DIMMH1
1 CPU 和 11 DIMM*	CPU1:P1-DIMMA1/P1-DIMMA2/P1-DIMMB1/P1-DIMMC1/P1-DIMMC2/P1-DIMMD1/P1-DIMME1/P1-DIMME2/P1-DIMMF1/P1-DIMMG1/P1-DIMMH1
1 CPU 和 12 DIMM	CPU1:P1-DIMMA1/P1-DIMMA2/P1-DIMMB1/P1-DIMMC1/P1-DIMMC2/P1-DIMMD1/P1-DIMME1/P1-DIMME2/P1-DIMMF1/P1-DIMMG1/P1-DIMMG2/P1-DIMMH1
1 CPU 和 13 DIMM*	CPU1:P1-DIMMA1/P1-DIMMA2/P1-DIMMB1/P1-DIMMB2/P1-DIMMC1/P1-DIMMC2/P1-DIMMD1/P1-DIMME1/P1-DIMME2/P1-DIMMF1/P1-DIMMF2/P1-DIMMG1/P1-DIMMH1
1 CPU 和 14 DIMM	CPU1:P1-DIMMA1/P1-DIMMA2/P1-DIMMB1/P1-DIMMB2/P1-DIMMC1/P1-DIMMC2/P1-DIMMD1/P1-DIMME1/P1-DIMME2/P1-DIMMF1/P1-DIMMF2/P1-DIMMG1/P1-DIMMG2/P1-DIMMH1
1 CPU 和 15 DIMM*	CPU1:P1-DIMMA1/P1-DIMMA2/P1-DIMMB1/P1-DIMMB2/P1-DIMMC1/P1-DIMMC2/P1-DIMMD1/P1-DIMMD2/P1-DIMME1/P1-DIMME2/P1-DIMMF1/P1-DIMMF2/P1-DIMMG1/P1-DIMMG2/P1-DIMMH1
1 CPU 和 16 DIMM	CPU1:P1-DIMMA1/P1-DIMMA2/P1-DIMMB1/P1-DIMMB2/P1-DIMMC1/P1-DIMMC2/P1-DIMMD1/P1-DIMMD2/P1-DIMME1/P1-DIMME2/P1-DIMMF1/P1-DIMMF2/P1-DIMMG1/P1-DIMMG2/P1-DIMMH1/P1-DIMMH2

注意: *不平衡配置 (由于性能下降, 不建议使用)

备注

- 本快速参考指南中显示的图形仅用于说明。您的组件外观可能与本指南中显示的图形不完全相同。
- 有关跳线、接口、LED指示灯、内存支持和CPU/主板安装说明的详细信息，请参阅用户手册第2章。

CPU和PHM安装

1 将针脚1作为基准，小心将处理器上的CPU键 (A和B) 与托架上的CPU键 (a和b) 对齐，如下图所示。正确对齐后，小心将处理器的一端放入托架上标有1的锁口中，并将处理器的另一端放入标有2的锁口中。

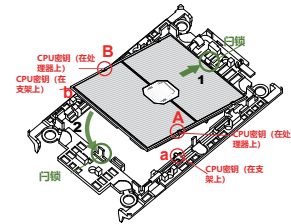
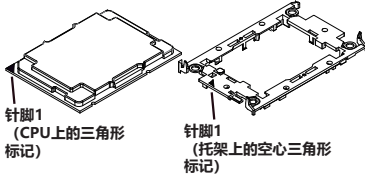

2 小心将处理器托架部件上标有“a”的边角放入标有“A”的散热器的边角。重复相同的步骤，将处理器托架部件上标有“b”、“c”、“d”的边角放入标有“B”、“C”、“D”的散热器的边角，确保所有塑料夹都正确连接到散热器上。

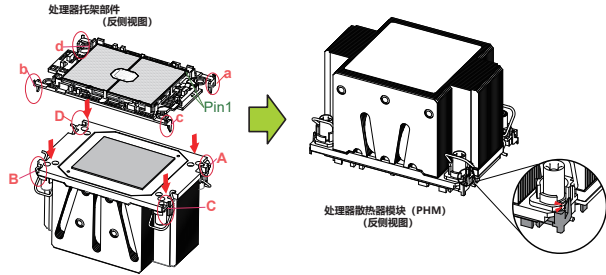

3 轻轻将处理器散热器模块 (PHM) 放在CPU插槽的顶部，确保每个PEEK螺母正确装配到相应的螺纹紧固件。

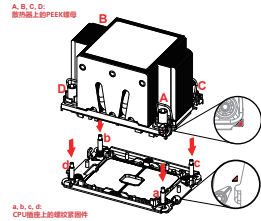

前面控制面板(JF1)

电源键	电源	1	2	接地
重启键	重启	3	4	接地
P3V3		5	6	电源故障指示灯
系统识别指示灯		7	8	过热/风扇故障指示灯
P3V3待机电源		9	10	网卡2 Active指示灯
P3V3待机电源		11	12	网卡1 Active指示灯
系统识别按钮		13	14	硬盘指示灯
P3V3		15	16	电源指示灯
X		17	18	X
不可屏蔽中断		19	20	接地

Power Button	PWR	1	2	Ground
Reset Button	Reset	3	4	Ground
P3V3		5	6	Power Fail LED
UID-LED		7	8	OH/Fan Fail LED
P3V3_STBY		9	10	NIC2 Active LED
P3V3_STBY		11	12	NIC1 Active LED
P3V3_STBY_UID SW		13	14	HDD LED
P3V3		15	16	PWR LED
X		17	18	X
SW_NMI_N		19	20	Ground

后面板I/O接口

1. LAN1: RJ45 1Gb LAN端口	6. 专用IPMI LAN 端口	11. USB6: USB 3.2 Gen. 1端口	16. 线路输入
2. USB9: USB 2.0端口	7. USB7: USB 3.2 Gen. 1端口	12. USB4: USB 3.2 Gen. 2x2端口	17. 线路输出
3. USB10: USB 2.0端口	8. USB8: USB 3.2 Gen. 1端口	13. 中心/LFE输出	18. 麦克风输入
4. COM1端口	9. LAN2: RJ45 10Gb LAN端口	14. 环绕输出	19. UID开关
5. VGA 端口	10. USB5: USB 3.2 Gen. 1端口	15. S/PDIF输出	

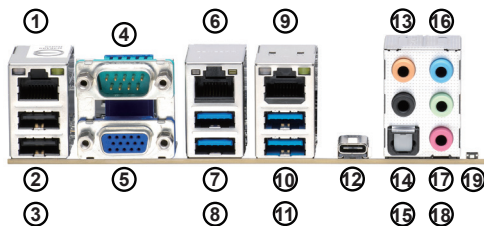

X12SPA-TF

MNL-2273-QRG-110

© 2025 美超微股份有限公司 (以下簡稱「本公司」) 版權所有。未經本公司書面同意，嚴禁複製本文件部分或全部內容。所有商標均為所屬公司所有。所有提供資訊均於印刷之際視為不保證正確。

マザーボードのレイアウトと機能

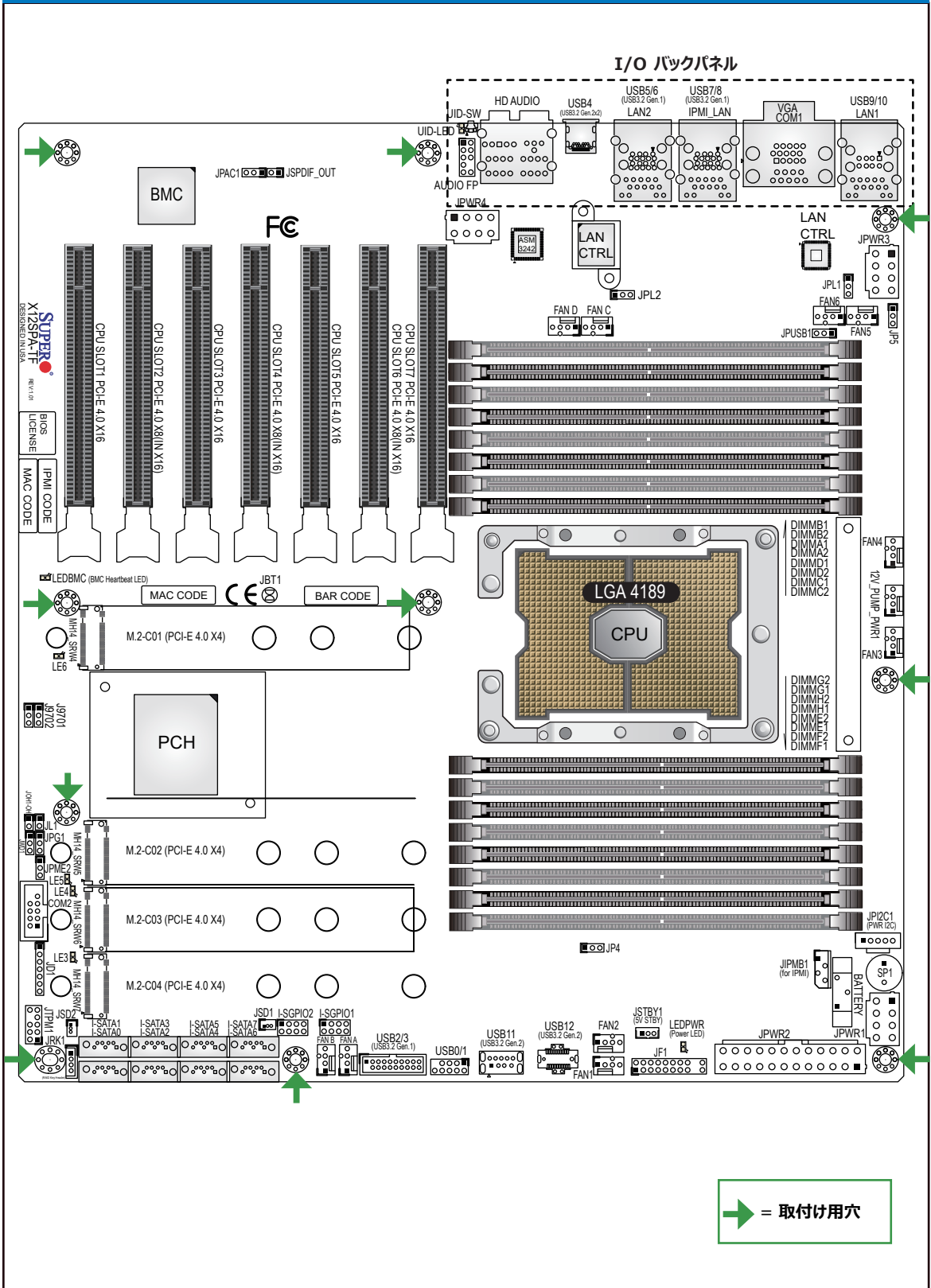

➡ = 取付け用穴

パッケージ内容

- Supermicro マザーボード 1枚
- SATA ケーブル 6本
- I/O シールド 1個
- クイック参照ガイド 1個
- GPU - CPU 電源ケーブル 1本
- CPU キャリアボード 1個

ジャンパーおよびコネクタ

ジャンパー		
ジャンパー	説明	デフォルト
J9701、J9702	デバッグモード	ピン 1-2 (ノーマル)
JBT1	CMOSクリア (基板上)	CMOSクリア用の短いパッド
JP4	USB11/12 無効化	ピン 1-2 (ノーマル)
JP5	USB4 無効化	ピン 1-2 (ノーマル)
JPAC1	HD オーディオ有効化/無効化	ピン 1-2 (有効)
JPG1	VGA 有効化/無効化	ピン 1-2 (有効)
JPL1、JPL2	LAN1/LAN2 有効化/無効化	ピン 1-2 (有効)
JPME2	Intel 製造モード	ピン 1-2 (ノーマル)
JPUSB1	USB7/8 ウェイクアップ	ピン 1-2 (有効)
JWD1	ウォッチドッグ機能の有効化	ピン 1-2 (リセット)

コネクタ	
コネクタ	説明
12V_PUMP_PWR1	12V 4ピン CPU水冷ポンプ用電源コネクタ
オーディオ FP	フロントパネル オーディオヘッダー
バッテリー	内蔵バッテリー
COM1、COM2	COM1 : COM ポート (バックパネル) 、COM2 : COM ヘッダー
CPU スロット1/3/5/7	PCIe 4.0 x16 スロット * M.2-C01もしくはM.2-C02が使用された場合、SLOT1が使用不可となります。 * M.2-C03もしくはM.2-C04が使用された場合、SLOT1がPCIe x8で動作します。 * SLOT2/4/6が使用された場合、SLOT3/5/7がそれぞれPCIe x8で動作します。
CPU スロット2/4/6	PCIe 4.0 x8 スロット (入力 x16)
ファン1 - ファン6	CPUファンヘッダー
ファン A - ファン D	システムファンヘッダー
HD オーディオ	バックパネル ハイデフィニション オーディオポート
I-SATA0 - I-SATA07	Intel シリアル ATA (SATA 3.0) ポート 0-7 (6Gb/秒)
I-SGPIO1、I-SGPIO2	シリアル 汎用 I/O ヘッダー
IPMI_LAN	専用 IPMI LAN ポート
JD1	電源 LED / スピーカーヘッダー (ピン 1-3 : 電源 LED 、ピン 4-7 : スピーカー)
JF1	フロント コントロールパネル ヘッダー
JIPMB1	4ピン 外部 I ² C ヘッダー (IPMI カード用)
JL1	シャーシ侵入ヘッダー
JOH1-OH	過熱 LED ヘッダー
JPI2C1	電源 SMBus I ² C ヘッダー
JPWR1/3/4	+12V 8ピン CPU 電源コネクタ (必須)
JPWR2	24ピン ATX 主電源コネクタ (必須)
JRK1	Intel VROC RAID キーヘッダー (注記 : M.2 RAID カードを有効にするには、VROC ハードウェアキーが必要です。)
JSD1、JSD2	SATA DOM (Disk-On-Module) 電源コネクタ
JSPDIF_OUT	Sony/Philips デジタルインターフェース (S/PDIF) 出力ヘッダー
JSTBY1	スタンバイ電源ヘッダー (5V)
JTPM1	Trusted Platform Module (TPM)/ポート 80 ヘッダー
LAN1、LAN2	LAN1 : RJ45 1GbE LAN ポート、LAN2 : RJ45 10GbE LAN ポート
M.2-C01 - M.2-C04	PCIe 4.0 x4 M.2 Mキーソケット (RAID 0/1/5/10 をサポート) * M.2-C03もしくはM.2-C04のどちらか、または両方使用された場合、CPU SLOT1のパフォーマンスに影響を与えます。 * 高速 NVMe SSD 用のスモールフォームファクターデバイスおよびその他のポータブルデバイス)
MH14_SRW4 - MH14_SRW7	M.2 取り付け用穴
SP1	内部スピーカー/ブザー
UID-SW	装置識別子 (UID) スイッチ
USB0/1	フロントアクセス USB 2.0 ヘッダー
USB2/3	フロントアクセス USB 3.2 Gen.1 ヘッダー
USB4	バックパネル USB 3.2 Gen.2x2 ポート
USB5、USB6、USB7、USB8	バックパネル USB 3.2 Gen.1 ポート
USB9、USB10	バックパネル USB 2.0 ポート
USB11	フロントアクセス USB 3.2 Gen.2 ポート
USB12	フロントアクセス USB 3.2 Gen.2 ヘッダー
VGA	VGA ポート

お問い合わせ先

- www.supermicro.com (Eメール : support@supermicro.com)
- マニュアル : <http://www.supermicro.com/support/manuals>
- ドライバーおよびユーティリティ : <https://www.supermicro.com/wdl/driver/>
- 安全性 : http://www.supermicro.com/about/policies/safety_information.cfm

LED インジケーター

LED インジケーター

LED	説明	カラー/状態
LE3、LE4、LE5、LE6	M.2-C04/M.2-C03/M.2-C02/M.2-C01 用 M.2 LED	緑色に点滅 : デバイス作動中
LEDBMC	BMC ハートビート LED	緑色に点滅 : BMC ノーマル
LEDPWR	内蔵電源 LED	緑色に点灯 : 電源オン
UID-LED	装置識別子 (UID) LED	ブルー オン : 装置を識別済み

CPU およびメモリサポート

X12SPA-TF マザーボードは、単一の第3世代 Intel Xeon Scalable/Intel Xeon W-33xx プロセッサに対応しています。メモリは最大 1TB の ECC RDIMM、4TB の 3DS RDIMM、2TB の LRDIMM、および 4TB の 3DS LRDIMMに対応しており、16個のDDR4 (288ピン) SMD DIMM スロットで最大 3200MHz (2DPC) の速度を実現します。これらの DIMM スロットにタイプとサイズが同じメモリモジュールのペアを装着した場合、インターリーブメモリが生成されてメモリパフォーマンスが向上します。メモリを取り付ける際には、1DPC および 2DPC を推奨します。一部の第3世代のみ。Intel Xeon Scalable-SP プロセッサは Intel Optane Persistent Memory (PMem) 200 シリーズに対応しています。

注記 : 1) メモリの最適化には、Supermicro によって検証済みの DIMM モジュールのみを使用してください。最新のメモリアップデートについては、当社のウェブサイト (<http://www.supermicro.com/products/motherboard>) を参照してください。

2) 電源コードは必ず最後につなげてください。ハードウェアコンポーネントを追加、取り外し、または変更する前には必ず抜いてください。

DIMM メモリ設置

↑ CPU の方向

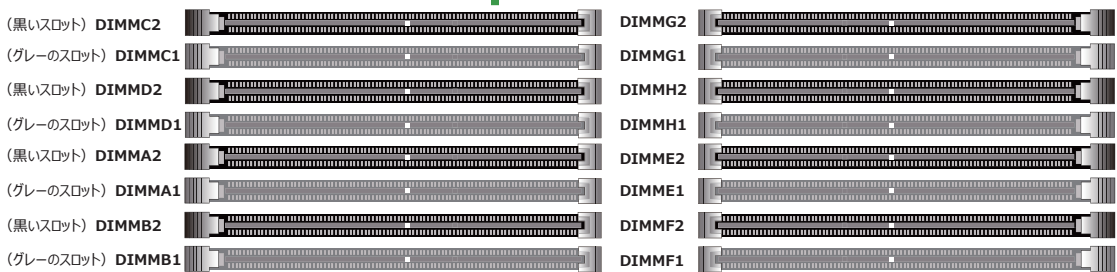

メモリ挿入ガイドライン

- 常にサイズ、タイプおよび速度が同じ DDR4 DIMM モジュールを使用してください。
- 異なる速度の DIMM を設置できます。しかしながら、すべての DIMM が最も遅い DIMM の速度で動作します。
- 特定のチャンネルでは、最初にグレースロットに挿入した場合にのみ、黒いスロットを有効にすることができます。

メモリ挿入表 (16個のスロット)

1個の CPU を使用する場合 :	メモリ挿入順序
1個の CPU & 1個の DIMM	CPU1 : P1-DIMMA1
1個の CPU & 2個の DIMM	CPU1 : P1-DIMMA1/P1-DIMME1
1個の CPU & 3個の DIMM*	CPU1 : P1-DIMMA1/P1-DIMME1/P1-DIMMC1
1個の CPU & 4個の DIMM	CPU1 : P1-DIMMA1/P1-DIMME1/P1-DIMMC1/P1-DIMMG1
1個の CPU & 5個の DIMM*	CPU1 : P1-DIMMA1/P1-DIMMB1/P1-DIMME1/P1-DIMMC1/P1-DIMMG1
1個の CPU & 6個の DIMM	CPU1 : P1-DIMMA1/P1-DIMMB1/P1-DIMME1/P1-DIMMF1/P1-DIMMC1/P1-DIMMG1
1個の CPU & 7個の DIMM*	CPU1 : P1-DIMMA1/P1-DIMMB1/P1-DIMMD1/P1-DIMME1/P1-DIMMF1/P1-DIMMC1/P1-DIMMG1
1個の CPU & 8個の DIMM	CPU1 : P1-DIMMA1/P1-DIMMB1/P1-DIMMD1/P1-DIMME1/P1-DIMMF1/P1-DIMMC1/P1-DIMMH1
1個の CPU & 9個の DIMM*	CPU1 : P1-DIMMA1/P1-DIMMA2/P1-DIMMB1/P1-DIMMC1/P1-DIMMD1/P1-DIMME1/P1-DIMMF1/P1-DIMMG1/P1-DIMMH1
1個の CPU & 10個の DIMM	CPU1 : P1-DIMMA1/P1-DIMMA2/P1-DIMMB1/P1-DIMMC1/P1-DIMMD1/P1-DIMME1/P1-DIMME2/P1-DIMMF1/P1-DIMMG1/P1-DIMMH1
1個の CPU & 11個の DIMM*	CPU1 : P1-DIMMA1/P1-DIMMA2/P1-DIMMB1/P1-DIMMC1/P1-DIMMC2/P1-DIMMD1/P1-DIMME1/P1-DIMME2/P1-DIMMF1/P1-DIMMG1/P1-DIMMH1
1個の CPU & 12個の DIMM	CPU1 : P1-DIMMA1/P1-DIMMA2/P1-DIMMB1/P1-DIMMC1/P1-DIMMC2/P1-DIMMD1/P1-DIMME1/P1-DIMME2/P1-DIMMF1/P1-DIMMG1/P1-DIMMG2/P1-DIMMH1
1個の CPU & 13個の DIMM*	CPU1 : P1-DIMMA1/P1-DIMMA2/P1-DIMMB1/P1-DIMMB2/P1-DIMMC1/P1-DIMMC2/P1-DIMMD1/P1-DIMME1/P1-DIMME2/P1-DIMMF1/P1-DIMMF2/P1-DIMMG1/P1-DIMMH1
1個の CPU & 14個の DIMM	CPU1 : P1-DIMMA1/P1-DIMMA2/P1-DIMMB1/P1-DIMMB2/P1-DIMMC1/P1-DIMMC2/P1-DIMMD1/P1-DIMME1/P1-DIMME2/P1-DIMMF1/P1-DIMMF2/P1-DIMMG1/P1-DIMMG2/P1-DIMMH1
1個の CPU & 15個の DIMM*	CPU1 : P1-DIMMA1/P1-DIMMA2/P1-DIMMB1/P1-DIMMB2/P1-DIMMC1/P1-DIMMC2/P1-DIMMD1/P1-DIMMD2/P1-DIMME1/P1-DIMME2/P1-DIMMF1/P1-DIMMF2/P1-DIMMG1/P1-DIMMG2/P1-DIMMH1
1個の CPU & 16個の DIMM	CPU1 : P1-DIMMA1/P1-DIMMA2/P1-DIMMB1/P1-DIMMB2/P1-DIMMC1/P1-DIMMC2/P1-DIMMD1/P1-DIMMD2/P1-DIMME1/P1-DIMME2/P1-DIMMF1/P1-DIMMF2/P1-DIMMG1/P1-DIMMG2/P1-DIMMH1/P1-DIMMH2

注記 : *不均衡な構成 (パフォーマンスが低下するため推奨されません)

注記

- 本クイック参照ガイドにある図は参考用です。お手元のコンポーネントは、本ガイドに示されている図と異なるか、まったく同一ではない可能性があります。
- 以下に関する詳細は第2章にあるユーザーマニュアルを参照してください：ジャンパー、コネクタ、LEDインジケータ、メモリスポートおよびCPU/マザーボードインストールガイド。

CPU および PHM の取り付け

1 ピン1をガイドとして使用して、下の図に示されているようにプロセッサの CPU キー（A および B）をキャリア（a および b）のCPUキーに慎重に合わせます。キーが適切に揃ったら、プロセッサの一方の端をキャリアの1とマーク付けされたラッチに慎重に差し込み、もう片方の端を2とマーク付けされたラッチに差し込みます。

2 プロセッサキャリアアセンブリにある「a」とマーク付けされている角を、「A」とマーク付けされているヒートシンクの角に慎重に差し込みます。同じ手順を繰り返して、プロセッサキャリアアセンブリの「b」、「c」、「d」とマーク付けされている角を「B」、「C」、「D」とマーク付けされているヒートシンクのタビに差し込み、すべてのプラスチッククリップがヒートシンクに適切に取り付けられているか確認します。

3 プロセッサヒートシンク モジュール（PHM）を CPU ソケットの上に慎重に配置し、各 PEEK ナットが対応するネジアスナーに正しく取り付けられていることを確認します。

フロントコントロールパネル（JF1）

		1	2			1	2			
電源ボタン	電源	○	○	接地		Power Button	PWR	○	○	Ground
リセットボタン	リセット	○	○	接地		Reset Button	Reset	○	○	Ground
	P3V3	○	○	電源障害LED			P3V3	○	○	Power Fail LED
	UID-LED	○	○	OH/ファン障害LED			UID-LED	○	○	OH/Fan Fail LED
	P3V3_STBY	○	○	NIC2アクティブLED			P3V3_STBY	○	○	NIC2 Active LED
	P3V3_STBY	○	○	NIC1アクティブLED			P3V3_STBY	○	○	NIC1 Active LED
	P3V3_STBY_UID SW	○	○	HDD LED			P3V3_STBY_UID SW	○	○	HDD LED
	P3V3	○	○	PWR LED			P3V3	○	○	PWR LED
	X	○	○	X			X	○	○	X
	SW_NMI_N	○	○	接地			SW_NMI_N	○	○	Ground
		19	20			19	20			

バックパネル I/O コネクタ

1. LAN1 : RJ45 1Gb LAN ポート	6. 専用 IPMI LAN ポート	11. USB6 : USB 3.2 Gen. 1 ポート	16. ライン入力
2. USB9 : USB 2.0 ポート	7. USB7 : USB 3.2 Gen. 1 ポート	12. USB4 : USB 3.2 Gen.2x2 ポート	17. ライン出力
3. USB10 : USB 2.0 ポート	8. USB8 : USB 3.2 Gen. 1 ポート	13. センター/ LFE 出力	18. マイク入力
4. COM1 ポート	9. LAN2 : RJ45 10Gb LAN ポート	14. サラウンド出力	19. UID スイッチ
5. VGA ポート	10. USB5 : USB 3.2 Gen. 1 ポート	15. S/PDIF 出力	

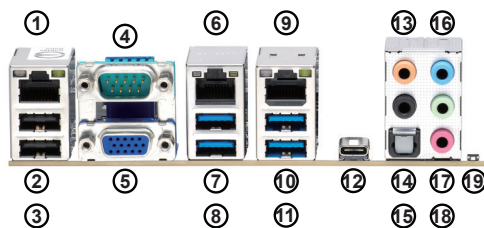

X12SPA-TF

메인보드 레이아웃 및 특징

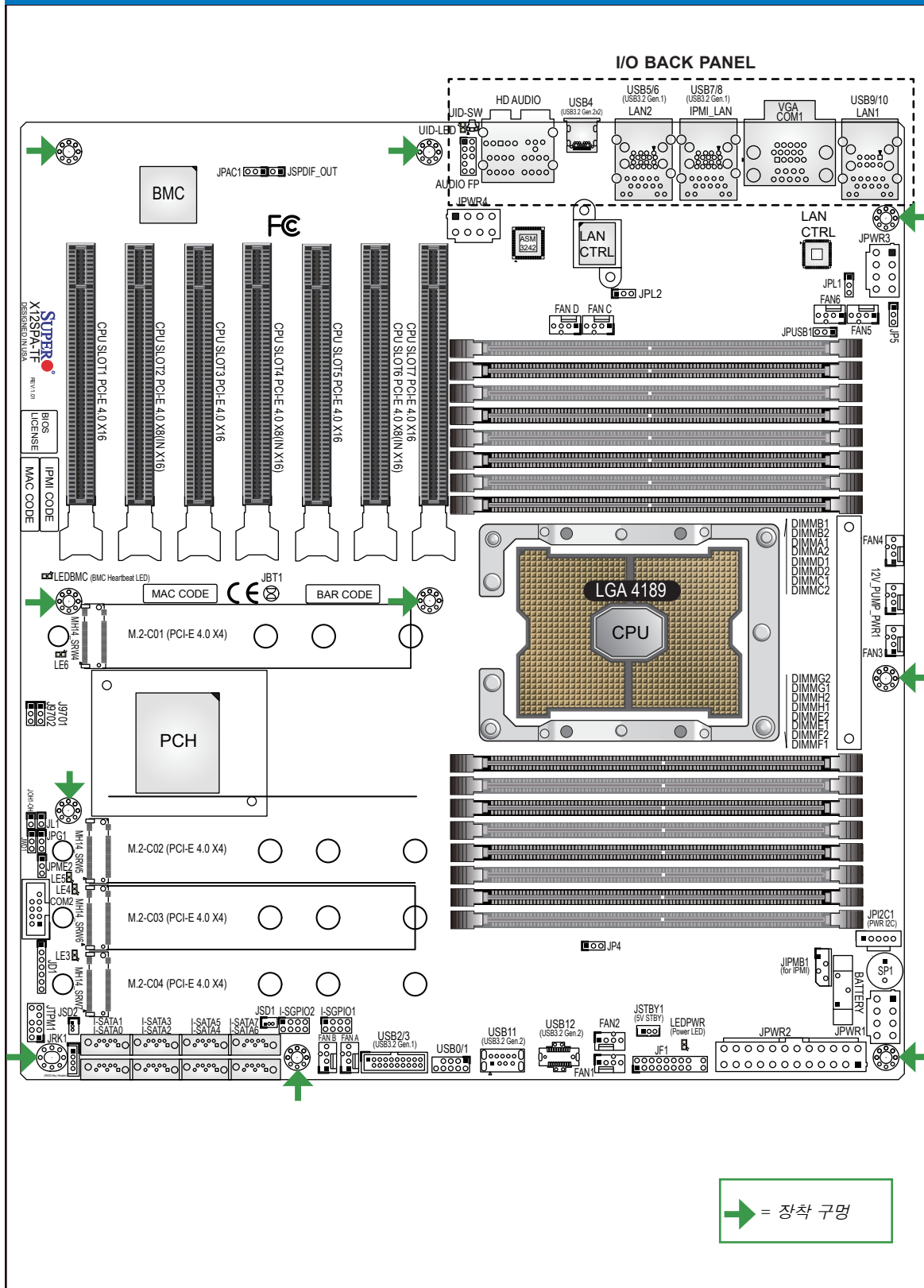

내용물

- Supermicro 메인보드 1개
- SATA 케이블 6개
- I/O 쉴드 1개
- 간편 참조 가이드 1부
- GPU와 CPU 연결 전원 케이블 1개
- CPU 캐리어 1개

점퍼 및 커넥터

점퍼		
점퍼	설명	기본값
J9701, J9702	디버그 모드	핀 1-2(일반)
JBT1	CMOS 지우기(온보드)	CMOS 클리어용 쇼트 패드
JP4	USB11/12 사용 안 함	핀 1-2(일반)
JP5	USB4 사용 안 함	핀 1-2(일반)
JPAC1	HD 오디오 사용/사용 안 함	핀 1-2(사용)
JPG1	VGA 사용/사용 안 함	핀 1-2(사용)
JPL1, JPL2	LAN1/LAN2 사용/사용 안 함	핀 1-2(사용)
JPME2	Intel ME 제조 모드	핀 1-2(일반)
JPUSB1	USB7/8 웨이크업	핀 1-2(사용)
JWD1	Watch Dog 기능 사용	핀 1-2(재설정)

커넥터	
커넥터	설명
12V_PUMP_PWR1	CPU 수냉 펌프용 12V 4핀 전원 커넥터
AUDIO FP	전면 패널 오디오 헤더
배터리	온보드 배터리
COM1, COM2	COM1: COM Port(후면 패널), COM2: COM 헤더
CPU SLOT1/3/5/7	PCIe 4.0 x16 슬롯 * SLOT1은 M.2-C01 또는 M.2-C02 중 하나를 사용하는 경우 비활성화됩니다. * M.2-C03 또는 M.2-C04를 사용하면 SLOT1이 PCIe x8로 변경됩니다. * SLOT2/4/6을 각각 사용하면 SLOT3/5/7이 PCIe x8로 변경됩니다.
CPU SLOT2/4/6	PCIe 4.0 x8 슬롯(IN x16)
FAN1 - FAN6	CPU 팬 헤더
FAN A - FAN D	시스템 팬 헤더
HD 오디오	후면 패널 고품질 오디오 포트
I-SATA0 - I-SATA07	Intel Serial ATA (SATA 3.0) 포트 0-7(6Gb/초)
I-SGPIO1, I-SGPIO2	연속 범용 I/O 헤더
IPMI_LAN	전용 IPMI LAN 포트
JD1	전원 LED / 스피커 헤더(핀 1-3: 전원 LED, 핀 4-7: 스피커)
JF1	전면 제어 패널 헤더
JIPMB1	4핀 외부 I ² C 헤더(IPMI 카드용)
JL1	새시 침입 헤더
JOH1-OH	과열 LED 헤더
JPI2C1	전원 공급 SMBus I ² C 헤더
JPWR1/3/4	+12V 8핀 CPU 전원 커넥터(필수)
JPWR2	24핀 ATX 주 전원 커넥터(필수)
JRK1	Intel VROC RAID 키 헤더 (참고: M.2 RAID 카드를 사용하도록 설정하려면 VROC 하드웨어 키가 필요합니다.)
JSD1, JSD2	SATA DOM(Disk-On-Module, 디스크 온 모듈) 전원 커넥터
JSPDIF_OUT	Sony/Philips 디지털 인터페이스(S/PDIF) 출력 헤더
JSTBY1	대기 전력 헤더(5V)
JTPM1	TPM/포트 80 헤더
LAN1, LAN2	LAN1: RJ45 1GbE LAN 포트, LAN2: RJ45 10GbE LAN 포트
M.2-C01 - M.2-C04	PCIe 4.0 x4 M.2 M-키 소켓 (RAID 0/1/5/10 지원) * M.2-C03 또는 M.2-C04 소켓 사용시 CPU SLOT1의 성능에 영향을 줄 수 있습니다. * 고속 NVMe SSD용 소형 폼 팩터 장치 및 다른 휴대용 장치
MH14_SRW4 - MH14_SRW7	M.2 장착 구멍
SP1	내부 스피커/버저
UID-SW	장치 식별자(UID) 스위치
USB0/1	전면 액세스 USB 2.0 헤더
USB2/3	전면 액세스 USB 3.2 Gen. 1 헤더
USB4	후면 패널 USB 3.2 Gen. 2x2 포트
USB5, USB6, USB7, USB8	후면 패널 USB 3.2 Gen. 1 포트
USB9, USB10	후면 패널 USB 2.0 포트
USB11	전면 액세스 USB 3.2 Gen. 2 포트
USB12	전면 액세스 USB 3.2 Gen. 2 헤더
VGA	VGA 포트

연락처 정보

- www.supermicro.com (이메일: support@supermicro.com)
- 사용 설명서: <http://www.supermicro.com/support/manuals>
- 드라이버 & 유틸리티: <https://www.supermicro.com/wdl/driver/>
- 안전: http://www.supermicro.com/about/policies/safety_information.cfm

LED 표시등

LED 표시등		
LED	설명	색/상태
LE3, LE4, LE5, LE6	M.2 LEDs for M.2-C04/M.2-C03/M.2-C02/M.2-C01	녹색으로 깜박임: 장치 작동 중
LEDBMC	BMC Heartbeat LED	녹색으로 깜박임: BMC 일반
LEDPWR	온보드 전원 LED	녹색으로 켜짐: 전원 켜기
UID-LED	장치 식별자(UID) LED	파란색으로 켜짐: 장치 식별됨

CPU 및 메모리 지원

X12SPA-TF 메인보드는 싱글 3세대 Intel Xeon Scalable/Intel Xeon W-33xx 프로세서를 지원합니다. 메모리는 최대 1TB의 ECC RDIMM, 4TB의 3DS RDIMM, 2TB의 LRDIMM 및 4TB의 3DS LRDIMM을, 그리고 16 DDR4(288-pin) SMD DIMM 슬롯에서 최대 3200 MHz(2DPC)의 속도를 지원합니다. DIMM 슬롯에 동일한 유형 및 크기의 메모리 모듈 쌍을 채우면 인터리브 메모리가 발생하여 메모리 성능이 향상됩니다. 메모리 설치 시 1DPC 및 2DPC가 권장됩니다. 특정 3세대 Intel Xeon Scalable-SP 프로세서만 Intel Optane Persistent Memory(PMem) 200 시리즈를 지원합니다.

참고: 1) 메모리 최적화를 위해 반드시 Supermicro의 인증을 받은 DIMM 모듈을 사용해야 합니다. 최신 메모리 업데이트는 웹사이트(<http://www.supermicro.com/products/motherboard>)를 참조하십시오.

2) 항상 전원 코드를 마지막에 연결하고 하드웨어 구성 요소를 추가, 제거, 또는 변경하기 전에 분리하십시오.

DIMM 메모리 설치

↑ CPU 방향



메모리 채우기 가이드라인

- 항상 동일한 크기, 유형 및 속도의 DDR4 DIMM 모듈을 사용하십시오.
- 혼합된 DIMM 속도를 설치해도 됩니다. 그러나 모든 DIMM가 가장 느린 DIMM 속도로 작동하게 됩니다.
- 지정된 채널에서 검정 슬롯은 먼저 회색 슬롯이 채워진 후에만 사용하도록 설정할 수 있습니다.

메모리 채우기 테이블(16개 슬롯 포함)	
1 CPU가 사용될 경우:	메모리 채우기 순서
1 CPU & 1 DIMM	CPU1: P1-DIMMA1
1 CPU & 2 DIMM	CPU1: P1-DIMMA1/P1-DIMME1
1 CPU & 3 DIMM*	CPU1: P1-DIMMA1/P1-DIMME1/P1-DIMMC1
1 CPU & 4 DIMM	CPU1: P1-DIMMA1/P1-DIMME1/P1-DIMMC1/P1-DIMMG1
1 CPU & 5 DIMM*	CPU1: P1-DIMMA1/P1-DIMMB1/P1-DIMME1/P1-DIMMC1/P1-DIMMG1
1 CPU & 6 DIMM	CPU1: P1-DIMMA1/P1-DIMMB1/P1-DIMME1/P1-DIMMF1/P1-DIMMC1/P1-DIMMG1
1 CPU & 7 DIMM*	CPU1: P1-DIMMA1/P1-DIMMB1/P1-DIMMD1/P1-DIMME1/P1-DIMMF1/P1-DIMMC1/P1-DIMMG1
1 CPU & 8 DIMM	CPU1: P1-DIMMA1/P1-DIMMB1/P1-DIMMD1/P1-DIMME1/P1-DIMMF1/P1-DIMMC1/P1-DIMMG1/P1-DIMMH1
1 CPU & 9 DIMM*	CPU1: P1-DIMMA1/P1-DIMMA2/P1-DIMMB1/P1-DIMMC1/P1-DIMMD1/P1-DIMME1/P1-DIMMF1/P1-DIMMG1/P1-DIMMH1
1 CPU & 10 DIMM	CPU1: P1-DIMMA1/P1-DIMMA2/P1-DIMMB1/P1-DIMMC1/P1-DIMMD1/P1-DIMME1/P1-DIMME2/P1-DIMMF1/P1-DIMMG1/P1-DIMMH1
1 CPU & 11 DIMM*	CPU1: P1-DIMMA1/P1-DIMMA2/P1-DIMMB1/P1-DIMMC1/P1-DIMMC2/P1-DIMMD1/P1-DIMME1/P1-DIMME2/P1-DIMMF1/P1-DIMMG1/P1-DIMMH1
1 CPU & 12 DIMM	CPU1: P1-DIMMA1/P1-DIMMA2/P1-DIMMB1/P1-DIMMC1/P1-DIMMC2/P1-DIMMD1/P1-DIMME1/P1-DIMME2/P1-DIMMF1/P1-DIMMG1/P1-DIMMG2/P1-DIMMH1
1 CPU & 13 DIMM*	CPU1: P1-DIMMA1/P1-DIMMA2/P1-DIMMB1/P1-DIMMB2/P1-DIMMC1/P1-DIMMC2/P1-DIMMD1/P1-DIMME1/P1-DIMME2/P1-DIMMF1/P1-DIMMF2/P1-DIMMG1/P1-DIMMH1
1 CPU & 14 DIMM	CPU1: P1-DIMMA1/P1-DIMMA2/P1-DIMMB1/P1-DIMMB2/P1-DIMMC1/P1-DIMMC2/P1-DIMMD1/P1-DIMME1/P1-DIMME2/P1-DIMMF1/P1-DIMMF2/P1-DIMMG1/P1-DIMMG2/P1-DIMMH1
1 CPU & 15 DIMM*	CPU1: P1-DIMMA1/P1-DIMMA2/P1-DIMMB1/P1-DIMMB2/P1-DIMMC1/P1-DIMMC2/P1-DIMMD1/P1-DIMMD2/P1-DIMME1/P1-DIMME2/P1-DIMMF1/P1-DIMMF2/P1-DIMMG1/P1-DIMMG2/P1-DIMMH1/P1-DIMMH2
1 CPU & 16 DIMM	CPU1: P1-DIMMA1/P1-DIMMA2/P1-DIMMB1/P1-DIMMB2/P1-DIMMC1/P1-DIMMC2/P1-DIMMD1/P1-DIMMD2/P1-DIMME1/P1-DIMME2/P1-DIMMF1/P1-DIMMF2/P1-DIMMG1/P1-DIMMG2/P1-DIMMH1/P1-DIMMH2

참고: *균형이 맞지 않는 구성(성능이 저하될 수 있어 권장되지 않음)

참고

- 본 간편 설명서의 그림들은 예시로만 사용됩니다. 실제 부품은 안내서에 표시된 도면과 동일하지 않을 수 있습니다.
- 점퍼, 커넥터, LED 표시등, 메모리 지원 및 CPU /메인보드 설치 지침에 대한 자세한 내용은 사용 설명서의 2장을 참조하십시오.

CPU 및 PHM 설치

1 핀 1을 가이드로 사용하여 아래 그림에서처럼 프로세서의 CPU 키(A 및 B)를 캐리어(a 및 b)의 CPU 키와 조심스럽게 정렬합니다. 올바르게 정렬되면 프로세서의 한쪽 끝을 캐리어에 1로 표시된 래치에 놓고 프로세서의 다른 끝을 2로 표시된 래치에 놓습니다.

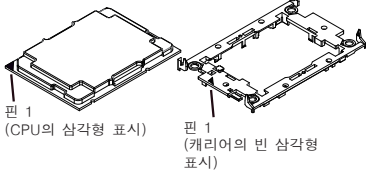

2 프로세서 캐리어 어셈블리에 "a"로 표시된 모서리를 "A"로 표시된 방열판의 모서리에 조심스럽게 놓습니다. 같은 단계를 반복하여 프로세서 캐리어 어셈블리에 "b", "c", "d"로 표시된 모서리를 "B", "C", "D"로 표시된 방열판의 모서리에 놓으면서 모든 플라스틱 클립이 적절하게 방열판에 부착되도록 합니다.

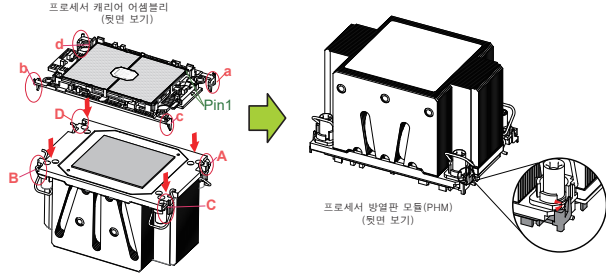

3 CPU 소켓 맨 위에 프로세서 방열판 모듈 (PHM)을 조심스럽게 놓으면서 각 PEEK 너트가 해당 스레드 패스너에 올바르게 부착되었는지 확인하십시오.

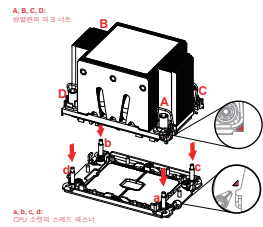

전면 제어 패널 (JF1)

전원 버튼	PWR	1	2	접지
재설정 버튼	Reset	1	2	접지
	P3V3	1	2	전원 실패 LED
	UID-LED	1	2	OH/팬 실패 LED
	P3V3_STBY	1	2	NIC2 활성 LED
	P3V3_STBY	1	2	NIC1 활성 LED
	P3V3_STBY_UID SW	1	2	HDD LED
	P3V3	1	2	PWR LED
	X	1	2	X
	SW_NMI_N	1	2	접지
		19	20	

Power Button	PWR	1	2	Ground
Reset Button	Reset	1	2	Ground
	P3V3	1	2	Power Fail LED
	UID-LED	1	2	OH/Fan Fail LED
	P3V3_STBY	1	2	NIC2 Active LED
	P3V3_STBY	1	2	NIC1 Active LED
	P3V3_STBY_UID SW	1	2	HDD LED
	P3V3	1	2	PWR LED
	X	1	2	X
	SW_NMI_N	1	2	Ground
		19	20	

후면 패널 I/O 커넥터

1. LAN1: RJ45 1Gb LAN 포트	6. 전용 IPMI LAN 포트	11. USB6: USB 3.2 Gen. 1 포트	16. 라인 입력
2. USB9: USB 2.0 포트	7. USB7: USB 3.2 Gen. 1 포트	12. USB4: USB 3.2 Gen. 2x2 포트	17. 라인 출력
3. USB10: USB 2.0 포트	8. USB8: USB 3.2 Gen. 1 포트	13. 중앙/LFE 출력	18. 마이크 입력
4. COM1 포트	9. LAN2: RJ45 10Gb LAN 포트	14. 서라운드 출력	19. UID 스위치
5. VGA 포트	10. USB5: USB 3.2 Gen. 1 포트	15. S/PDIF 출력	

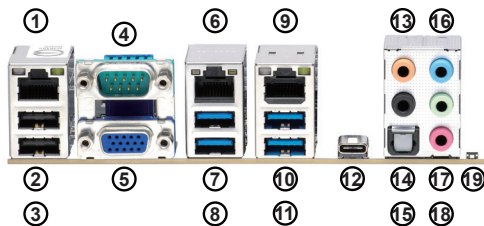

Notes

