

SUPERMICR® X14SBGM Quick Reference Guide

Package Contents
 • One Supermicro Motherboard
 • One Quick Reference Guide

WARNING: This product can expose you to chemicals including lead, known to the State of California to cause cancer and birth defects or other reproductive harm. For more information, go to www.P65Warnings.ca.gov.

Motherboard Layout and Features

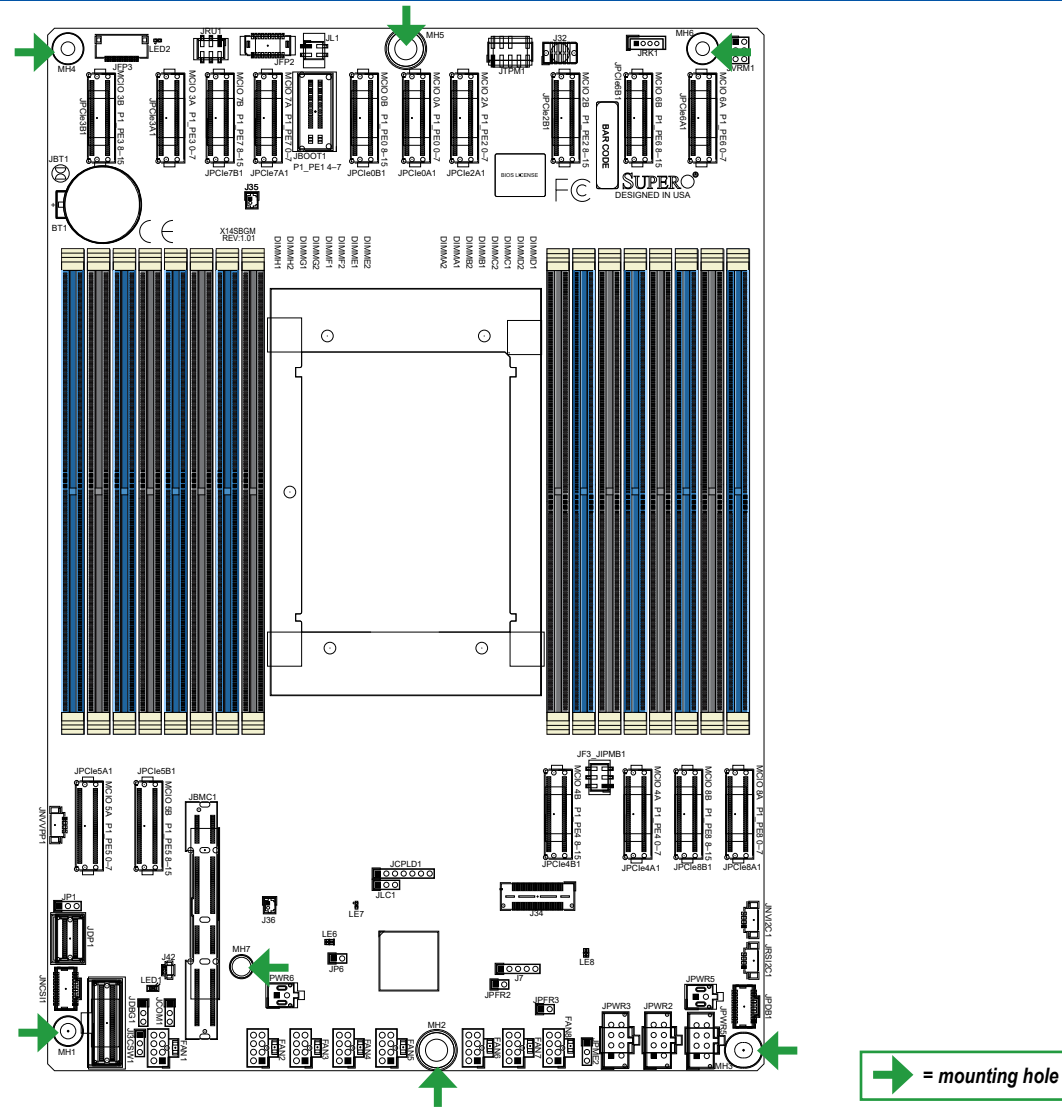

Processor and PHM Installation

1 Assemble the processor carrier assembly by aligning and placing one end of the processor into the latch marked A, and place the other end of processor into the latch marked B.

2 To form the processor heatsink module (PHM), mount the processor carrier assembly onto the heatsink and snap into place.

3 After assembling the PHM, mount it onto the processor socket. With a T30 bit torque driver set to a force of 8.0 in-lbf (0.904 N-m), gradually tighten the four screws.

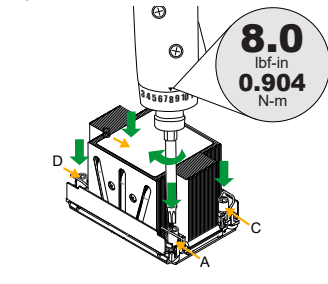
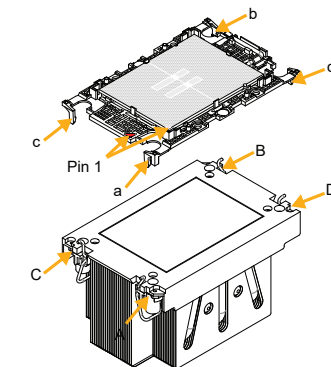
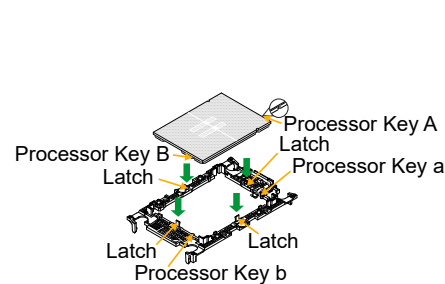

The processor carriers (SKT-1543H-0000-FXC and SKT-1544H-0000-FXC) are included in the shipping package.

Jumpers and Connectors

Jumpers		
Jumper	Description	Default Setting
JBT1	CMOS Clear	Open (Normal)
J1°C SW1	1°C Functionality Jumper	Pins 1–2 (1°C)
JLC1	Cooling Select Jumper	Pins 1–2 (Air Cool)
JRU1	UID/Reset Button Select Jumper	Pins 1–2 (UID)

Connectors	
Connector	Description
BT1	CMOS Battery
CN4	I/O Module Connector
FAN1–FAN8	Fan Headers
J35, J36	Liquid Cooling Leakage Sensor Connectors
JBMC1	External BMC Module Connector
JBOOT (P1_PE1 4–7)	M.2 Boot Tray Connector for AOM-DCM2-BOOT
JCPLD1	CPLD Connector
JFP3	Front Control Panel Header
JL1	Chassis Intrusion Header
JNCSI1	NC-SI Connection
JNV1°C1	NVMe Backplane 1°C Connector
JNVVPP1	NVMe VPP Header
JPDB1	Power Distributor Board Sideband Signal Header
JPWR1–JPWR3	8-pin +12 V GPU MICRO-HI Power Connectors
JPWR5	2-pin +12 V Standby Input from PSU
JPWR6	2-pin +12 V Standby Output to I/O Module (AOM-IO-GP102)
JRK1	Intel VROC Raid Key Header
JRS1°C1	Fan Board Control Header
JTPM1	Trusted Platform Module/Port 80 Connector

MCIO 0A, MCIO 0B, MCIO 2A, MCIO 2B, MCIO 3A, MCIO 3B, MCIO 4A, MCIO 4B, MCIO 5A, MCIO 5B, MCIO 6A, MCIO 6B, MCIO 7A, MCIO 7B, MCIO 8A, MCIO 8B
 MCIO PCIe 5.0 x8 Connectors

LED Indicators		
LED	Description	Status
LE6	Power Regulator LED	Green: Power Ready Amber: Standby Red: Power Failure
LED2	Onboard Power LED	Off: System Off Green: System On

Processor Support

The X14SBGM motherboard supports the Intel® Xeon® 6700-series processors with rich P-cores in Socket E2 LGA 4710 with a Thermal Design Power (TDP) of up to 350 W.

Memory Support

The motherboard supports up to 4 TB of DDR5 RDIMM/3DS RDIMM with speeds of up to 6400 MT/s (1DPC) and 5200 MT/s (2DPC) in 32 GB, 64 GB, 96 GB, 128 GB, and 256 GB RDIMM/3DS RDIMM sizes.

The motherboard supports up to 512 GB of DDR5 MRDIMM-8800 with speeds of up to 8000 MT/s in 32 GB and 64 GB MRDIMM-880 sizes.

- It is recommended to use DDR5 memory of the same type, size, and speed.
- Mixed DIMM speeds can be installed. However, all DIMMs will run at the speed of the slowest DIMM.
- The motherboard will support an odd number amount of memory modules. However, to achieve the best memory performance, a balanced memory population is recommended.

Number of DIMMs	Memory Population Sequence (RDIMM/3DS RDIMM)
1 (Recommended)	DIMMA1
4	DIMMA1/DIMMC1/DIMME1/DIMMG1 DIMMB1/DIMMD1/DIMMF1/DIMMH1
8	DIMMA1/DIMMA2/DIMMC1/DIMMC2/DIMME1/DIMME2/DIMMG1/DIMMG2 DIMMB1/DIMMB2/DIMMD1/DIMMD2/DIMMF1/DIMMF2/DIMMH1/DIMMH2 DIMMA1/DIMMB1/DIMMC1/DIMMD1/DIMMF1/DIMMG1/DIMMH1 (Recommended)
16 (Recommended)	DIMMA1/DIMMA2/DIMMB1/DIMMB2/DIMMC1/DIMMC2/DIMMD1/DIMMD2/DIMME1/DIMME2/ DIMMF1/DIMMF2/DIMMG1/DIMMG2/DIMMH1/DIMMH2

Number of DIMMs	Memory Population Sequence (MRDIMM)
8	DIMMA1/DIMMB1/DIMMC1/DIMMD1/DIMME1/DIMMF1/DIMMG1/DIMMH1

Front Control Panel (JFP3)

JFP3

- 1 ○ Power Button
- 2 ○ Reset/UID Button
- 3 ○ UID LED_N
- 4 ○ Fail LED_N (OH/FF/PF)
- 5 ○ LAN-2 Activity LED
- 6 ○ LAN-1 Activity LED (Aggregate all LAN)
- 7 ○ Storage Drive Activity LED
- 8 ○ Standby LED_N
- 9 ○ Power/RoT LED_N
- 10 ○ P3V3_STBY
- 11 ○ GND
- 12 ○ I2C Data
- 13 ○ I2C Clock
- 14 ○ GND
- 15 ○ Power Fail LED_P
- 16 ○ P5V_USB
- 17 ○ P5V_USB
- 18 ○ P5V_USB
- 19 ○ Power Fail LED_N
- 20 ○ GND