



X14SRA-T
X14SRA-F

ENGLISH

繁體中文

简体中文

日本語

한국어

QUICK REFERENCE GUIDE

Revision 1.0a

Standardized Warning Statements

Motherboards

About Standardized Warning Statements

The following statements are industry standard warnings, provided to warn the user of situations where bodily injury might occur. Should you have questions or experience difficulty, contact Supermicro's Technical Support Department for assistance. Only certified technicians should attempt to install or configure components.

Read this section in its entirety before installing or configuring components in the Supermicro chassis.



WARNING: This product can expose you to chemicals including lead, known to the State of California to cause cancer and birth defects or other reproductive harm. For more information, go to www.P65Warnings.ca.gov.

Battery Handling



Warning!

There is a danger of explosion if the battery is replaced incorrectly. Replace the battery only with the same or an equivalent type recommended by the manufacturer. Dispose of used batteries according to the manufacturer's instructions.

警告

電池更換不當會有爆炸危險。請使用製造商建議之相同或功能相當的電池更換原有電池。請按照製造商的說明指示處理廢棄舊電池。

警告

電池更換不當會有爆炸危險。請只使用同類電池或製造商推薦的功能相當的電池更換原有電池。請按製造商的說明處理廢舊電池。

電池の取り扱い

電池交換が正しく行われなかった場合、破裂の危険性があります。交換する電池はメーカーが推奨する型、または同等のものを使用下さい。使用済電池は製造元の指示に従って処分して下さい。

경고!

배터리가 올바르게 교체되지 않으면 폭발의 위험이 있습니다. 기존 배터리와 동일하거나 제조사에서 권장하는 동등한 종류의 배터리로만 교체해야 합니다. 제조사의 안내에 따라 사용된 배터리를 처리하여 주십시오.

هناك خطر من انفجار في حالة استبدال البطارية بطريقة غير صحيحة فعليك استبدال البطارية فقط بنفس النوع أو ما يعادلها كما أوصت به الشركة المصنعة تخلص من البطاريات المستعملة وفقا لتعليمات الشركة الصانعة

限用物質含有情況標示聲明書

Declaration of the Presence Condition of the Restricted Substances Marking

設備名稱：主機板 / Motherboard Equipment name						
型號（型式）：X14SRA-T, X14SRA-F Type designation (Type)						
單元 Unit	限用物質及其化學符號 Restricted substances and its chemical symbols					
	鉛Lead (Pb)	汞Mercury (Hg)	鎘Cadmium (Cd)	六價鉻 Hexavalent chromium (Cr ⁺⁶)	多溴聯苯 Polybrominated biphenyls (PBB)	多溴二苯醚 Polybrominated diphenyl ethers (PBDE)
印刷電路板 組件 \\(PCBA)	—	○	○	○	○	○
連接器 (Connector)	—	○	○	○	○	○
鈕扣電池 (Coin Battery)	○	○	○	○	○	○
電子零件 (Electronic component)	—	○	○	○	○	○
<p>備考1. “超出0.1 wt %” 及 “超出0.01 wt %” 係指限用物質之百分比含量超出百分比含量基準值。</p> <p>Note 1 : “Exceeding 0.1 wt %” and “exceeding 0.01 wt %” indicate that the percentage content of the restricted substance exceeds the reference percentage value of presence condition.</p> <p>備考2. “○” 係指該項限用物質之百分比含量未超出百分比含量基準值。</p> <p>Note 2 : “○” indicates that the percentage content of the restricted substance does not exceed the percentage of reference value of presence.</p> <p>備考3. “—” 係指該項限用物質為排除項目。</p> <p>Note 3 : The “—” indicates that the restricted substance corresponds to the exemption.</p>						

AMI BIOS POST Codes

About AMI BIOS POST Codes

The table below lists some of AMI BIOS POST codes for this motherboard. For more information, refer to https://www.supermicro.com/manuals/other/AMI_AptioV_BIOS_POST_Codes_for_SM_Motherboards.pdf.

Code	Description
0x32	CPU post-memory initialization is started
0x55	No Memory detected or memory failed
0x63	CPU DXE initialization is started
0x69	North Bridge DXE initialization is started
0x70	South Bridge DXE initialization is started
0x92	PCI Bus initialization is started
0x99	Super IO Initialization
0x9A	USB initialization is started
0xA0	IDE initialization is started
0xA9	Boot into BIOS setup menu
0xAE	Legacy Boot event
0xB2	Legacy Option ROM Initialization
0xB4	USB hot plug
0xD6	No console output devices are found
0xD7	No console input devices are found
0xF2	Recovery process started
0xF9	Recovery capsule is not found

M.2 Device Installation

M.2 Device Installation

This motherboard has two PCIe 5.0 M.2 M-key slots (M.2-C1 and M.2-C2) that support the M.2 2280/22110 modules.

One standoff is pre-installed in the position of each 22110 mounting hole (M.2-C1 and M.2-C2).

Refer to the illustration on the right for the locations of M.2 slots and mounting holes. Follow the steps below to install the M.2 device.

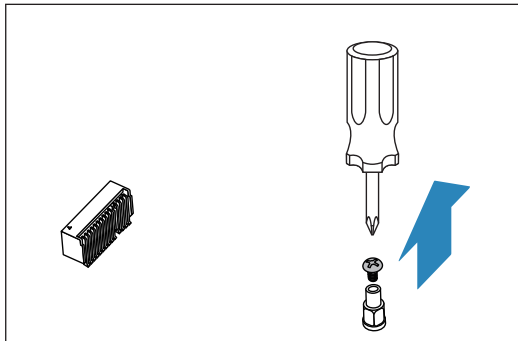
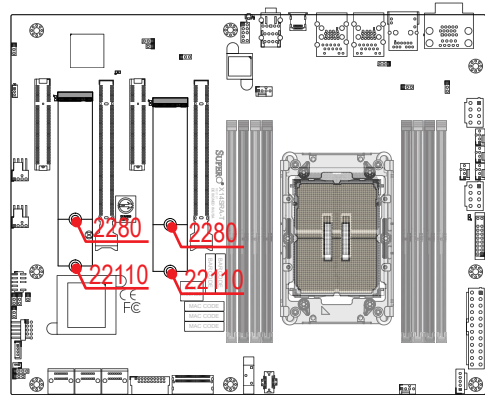

1. Locate the screw on the pre-installed standoff. Remove the screw and set it aside.

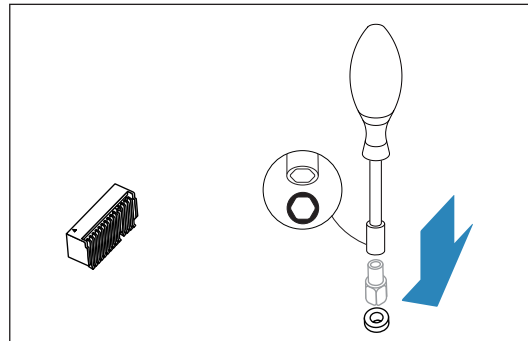

2. If the soon-to-be used mounting hole doesn't have a standoff, move the pre-installed one to that mounting hole.

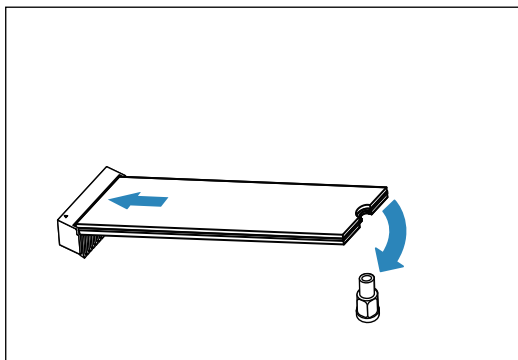

3. Carefully insert the M.2 device into the M.2 slot at a 30-degree angle and lower the semi-circle notched end onto the standoff.

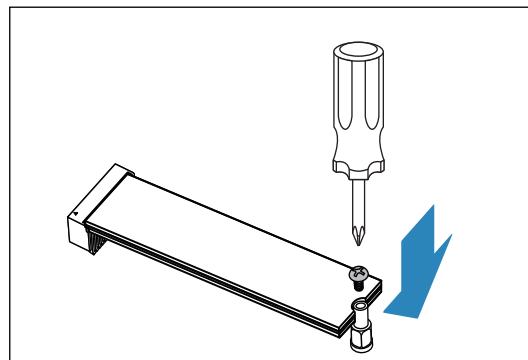

4. Tighten the standoff screw to secure the M.2 device into place. Do not over-tighten so as to avoid damaging the M.2 device.

 **Note:** It is recommended that you use the M.2 heatsink provided by the M.2 device supplier.

Memory Population

Memory Population Table

DDR5 Memory Population Table										
DDR5	DIMMC1	DIMMC2	DIMMA1	DIMMA2	CPU	DIMME2	DIMME1	DIMMG2	DIMMG1	
1			DDR5							
							DDR5			
2			DDR5							DDR5
	DDR5							DDR5		
4	DDR5		DDR5					DDR5		DDR5
8	DDR5	DDR5	DDR5	DDR5			DDR5	DDR5	DDR5	DDR5

DDR5 Memory Support for Intel® Xeon® 600 Series Processors

DDR5 Memory Support for Intel Xeon 600 Series Processors									
Type	Ranks Per DIMM and Data Width (Stack)	DIMM Capacity (GB)					Voltage (V); DIMMs per Channel (DPC)		
		DRAM Density (Gb)					+1.1 V		
		16 Gb		24 Gb		32 Gb	DIMM Speed (MT/s)	1DPC Speed (MT/s)	2DPC Speed (MT/s)
		1DPC	2DPC	1DPC	2DPC	1/2DPC			
RDIMM	1Rx8	16 GB	16 GB	24 GB	24 GB	-	6400	Up to 6400*	Up to 5200*
	1Rx4	32 GB	32 GB	48 GB	48 GB	-			
	2Rx8	32 GB	32 GB	48 GB	-	-			
	2Rx4	64 GB	64 GB	96 GB	96 GB	128 GB			
3DS RDIMM	4Rx4	-	-	-	-	256 GB			
	8Rx4	256 GB	256 GB	-	-	-			
MRDIMM	2Rx8	32 GB	-	-	-	-	8800	Up to 8000*	N/A
	2Rx4	64 GB	-	-	-	-			

Note 1: The supported 1DPC and 2DPC speeds are based on Intel POR.

Note 2: The speeds marked with an asterisk (*) are based on the top-tier processor SKUs. Other processor SKUs may support lower memory speeds. Refer to <https://ark.intel.com> for specific SKU's maximum memory speed.

GPU Cards and the Required Power Connectors

Important: To provide adequate power supply to the motherboard, be sure to connect the 24-pin ATX power connector and the required 8-pin power connectors to the power supply. Failure to do so may void the manufacturer warranty on your power supply and motherboard.

When installing multiple GPU cards, it is strongly recommended that you connect the power supplies to the 24-pin ATX power connector (JPW1) and both 8-pin power connectors (JPW2 and JPW3) to the power supply.

GPU Cards and the Required Power Connectors				
Type of GPU	Number of GPU Cards	JPW1	JPW2	JPW3
Single-Width	GPU x1	✓	✓	✓
	GPU x2	✓	✓	✓
	GPU x3	✓	✓	✓
Double-Width	GPU x1	✓	✓	✓
	GPU x2	✓	✓	✓
Triple-Width	GPU x1	✓	✓	✓
	GPU x2	✓	✓	✓

 **Note 1:** When using heavy loading devices, it is strongly recommended that you connect the power supplies to the 24-pin ATX power connector and all the 8-pin power connectors.

Note 2: To use the CPU overclocking feature, be sure to connect the power supplies to the 24-pin ATX power connector and all the 8-pin power connectors.

Note 3: To avoid possible system overheating, be sure to provide adequate airflow to your system.

Notes

Motherboard Layout and Features

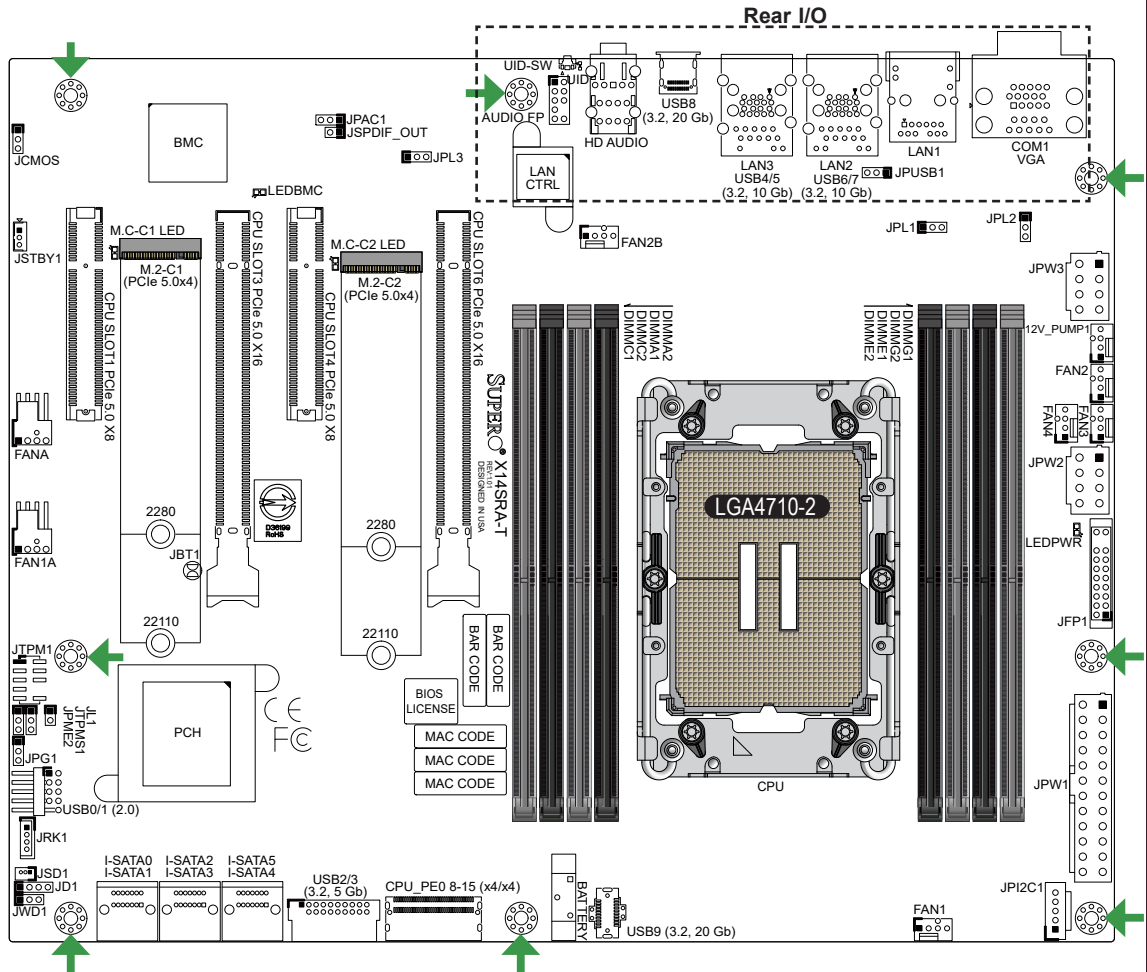

Differences of Rear I/O between X14SRA-T and X14SRA-F

	X14SRA-T	X14SRA-F
LAN1 : RJ45 1 GbE LAN Port	N/A	Yes
LAN3 : RJ45 10 GbE LAN Port	Yes	N/A
UID Switch	N/A	Yes
VGA Port	N/A	Yes

➔ = mounting hole

PACKAGE CONTENTS

- One Supermicro Motherboard
- Six SATA Cables
- One Quick Reference Guide
- One CPU Carrier E2A for Intel Xeon 600 Series XCC Processors
- One I/O Shield
- One CPU Carrier E2B for Intel Xeon 600 Series HCC/LCC Processors

LED Indicators and Connectors

LED Indicators

LED	Description	Color/State
LEDBMC	BMC Heartbeat LED (X14SRA-F only)	Blinking Green: BMC Normal
LEDPWR	Onboard Power LED	Solid Green: Power On
M.C-C1 LED, M.C-C2 LED	M.2 LEDs for M.2-C1/M.2-C2	Blinking Green: Device Working
UID	Unit Identifier (UID) LED (X14SRA-F only)	Solid Blue: Unit Identified

Connectors

Connector	Description
12V_PUMP1	+12 V 4-pin Power Connector (for CPU liquid cooling pump)
AUDIO FP	Front Panel Audio Header
BATTERY	Onboard Battery
COM1	Rear COM Port
CPU_PE0 8-15 (x4/x4)	PCIe 5.0 x8 MCIO Connector supporting two U.2 connections (from CPU, with support of RAID 0/1)
FAN1–FAN4	CPU Fan Headers
FANA, FAN1A, FAN2B	System Fan Headers
HD AUDIO	Rear High Definition Audio Ports
I-SATA0–I-SATA5	Intel SATA 3.0 Ports (from PCH, 6 Gbps, with support of RAID 0/1/5/10)
JD1	External Speaker/Buzzer Header
JFP1	Front Control Panel Header
JL1	Chassis Intrusion Header
JPI2C1	Power Supply System Management Bus (SMBus) I2C Header (X14SRA-F only)
JPW1	24-pin ATX Main Power Connector (Required)
JPW2, JPW3	+12 V 8-pin CPU Power Connectors
JRK1	Intel VROC RAID Key Header * A VROC hardware key is required for VROC RAID function.
JSD1	SATA Disk-On-Module (DOM) Power Connector
JSPDIF_OUT	Sony/Philips Digital Interface (S/PDIF) Out Header
JSTBY1	Standby Power Header (5 V)
JTPM1	Trusted Platform Module (TPM)/Port 80 Header (TPM 2.0 only)
LAN1	RJ45 1 GbE LAN Port (shared BMC LAN port, X14SRA-F only)
LAN2	RJ45 1 GbE LAN Port (with support of Intel vPro®)
LAN3	RJ45 10 GbE LAN Port (X14SRA-T only)
M.2-C1, M.2-C2	PCIe 5.0 x4 M.2 M-key Slots (from CPU, with support of 2280/22110 form factors and RAID 0/1)
SLOT1, SLOT4	PCIe 5.0 x8 Slots (from CPU)
SLOT3, SLOT6	PCIe 5.0 x16 Slots (from CPU)
UID-SW	Unit Identifier (UID) Switch (X14SRA-F only)
USB0/1	Front Accessible USB 2.0 Header
USB2/3	Front Accessible USB 3.2 Gen 1 Header (5 Gb, Type-A)
USB4/5	Rear USB 3.2 Gen 2x1 Ports (10 Gb, Type-A)
USB6/7	Rear USB 3.2 Gen 2x1 Ports (10 Gb, Type-A)
USB8	Rear USB 3.2 Gen 2x2 Port (20 Gb, Type-C)
USB9	Front Accessible USB 3.2 Gen 2x2 Header (20 Gb, Type-C)
VGA	VGA Port supported by BMC (X14SRA-F only)

CONTACT INFORMATION

- www.supermicro.com (Email: support@supermicro.com)
- Manuals: <https://www.supermicro.com/support/manuals>
- Drivers & Utilities: <https://www.supermicro.com/wdl/driver/>
- Safety: https://www.supermicro.com/about/policies/safety_information.cfm

Jumpers

Jumpers		
Jumper	Description	Default Setting
JBT1	Clear CMOS (Onboard)	Short Pads to Clear CMOS
JCMOS	Clear CMOS (Onboard)	Pins 1-2 (Normal)
JPAC1	HD Audio Normal/Disable	Pins 1-2 (Normal)
JPG1	BMC VGA Function (X14SRA-F only)	Pins 1-2 (Enabled)
JPL1	LAN1 Enable/Disable (X14SRA-F only)	Pins 1-2 (Enabled)
JPL2	LAN2 Enable/Disable	Pins 1-2 (Enabled)
JPL3	LAN3 Enable/Disable (X14SRA-T only)	Pins 1-2 (Enabled)
JPME2	Intel Manufacturing Mode	Pins 1-2 (Normal)
JPUSB1	USB6/7 Standby Power	Pins 1-2 (Enabled)
JTPMS1	TPM Selection (Onboard/Header)	Pins 1-2: Onboard TPM (Default) Pins 2-3: TPM Header/Port 80 Header
JWD1	Watchdog Function Enable	Pins 1-2 (Reset)

CPU and Memory Support

The X14SRA-T/X14SRA-F motherboard supports a single Intel Xeon 600 Series processor (LGA4710-2/Socket E2). The eight DDR5 memory slots support up to 1 TB of ECC RDIMM and 2 TB of ECC 3DS RDIMM with speeds of up to 6400 MT/s (1DPC) or 5200 MT/s (2DPC) and 256 GB of ECC MRDIMM with speeds of up to 8000 MT/s (1DPC).

Populating these DIMM slots with a pair of memory modules of the same type and size will result in interleaved memory, which will improve memory performance.

-  **Notes:** 1) For memory optimization, use only DIMM modules that have been validated by Supermicro. For the latest memory updates, please refer to our website at <https://www.supermicro.com/products/motherboard>.
- 2) Always connect the power cord last, and always remove it before adding, removing, or changing any hardware components.

DIMM Memory Installation

Memory Population Guidelines

- It is recommended to use DDR5 DIMM modules of the same size, type, and speed.
- Mixed DIMM speeds can be installed. However, all DIMMs will run at the speed of the slowest DIMM.
- In a given channel, the black slot can be enabled only when the gray slot is populated first.
- The DDR5 DIMM module is NOT hot-swappable and be sure to disconnect power for a minimum of 20 seconds before inserting or removing it.
- Removing a DDR5 DIMM module at a slanted angle will cause damages. It is strongly recommended that you lift the module straight up out of the slot.

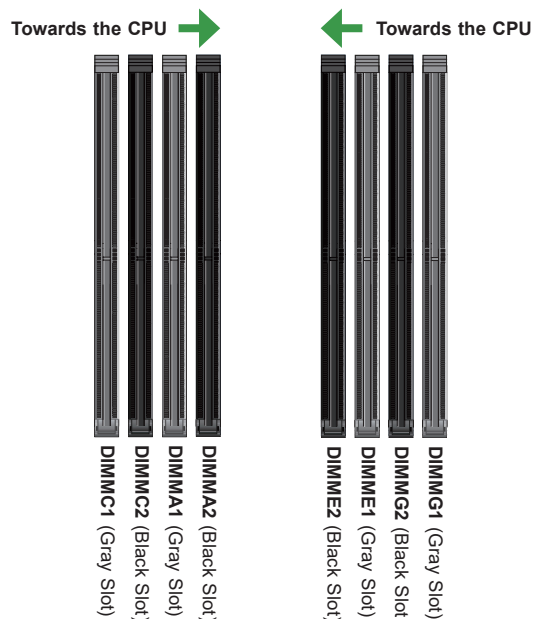

NOTES

- Graphics shown in this quick reference guide are for illustration only. Your components may or may not look exactly the same as drawings shown in this guide.
- Refer to User's Manual for detailed information on jumpers, connectors, LED indicators, memory support and CPU/motherboard installation instructions.

CPU Installation

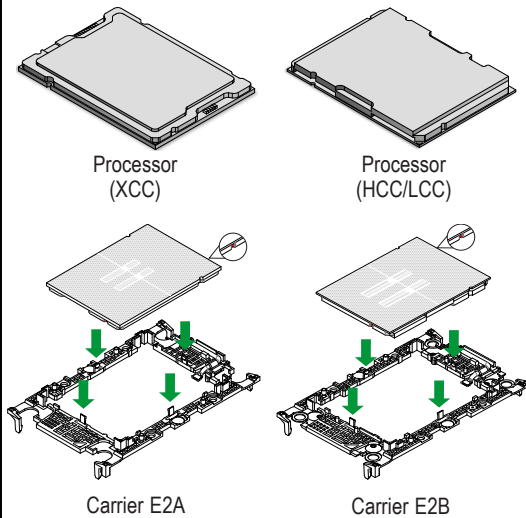

Front Control Panel (JFP1)

	20	19	
GND	○	○	NMI
NC	○	○	NC
FP PWR LED	○	○	+3.3 V Stby
HDD LED	○	○	+3.3 V Stby (X14SRA-T) UID SW (X14SRA-F)
NIC1 LED	○	○	+3.3 V Stby
NIC2 LED	○	○	+3.3 V Stby
OH/Fan Fail/PWR Fail LED	○	○	NC (X14SRA-T) UID LED (X14SRA-F)
NC (X14SRA-T) PWR Fail LED (X14SRA-F)	○	○	+3.3 V
GND	○	○	Reset } Reset Button
GND	○	○	PWR } Power Button
	2	1	

(NC=No Connection)

Processor Heatsink Module (PHM) Installation

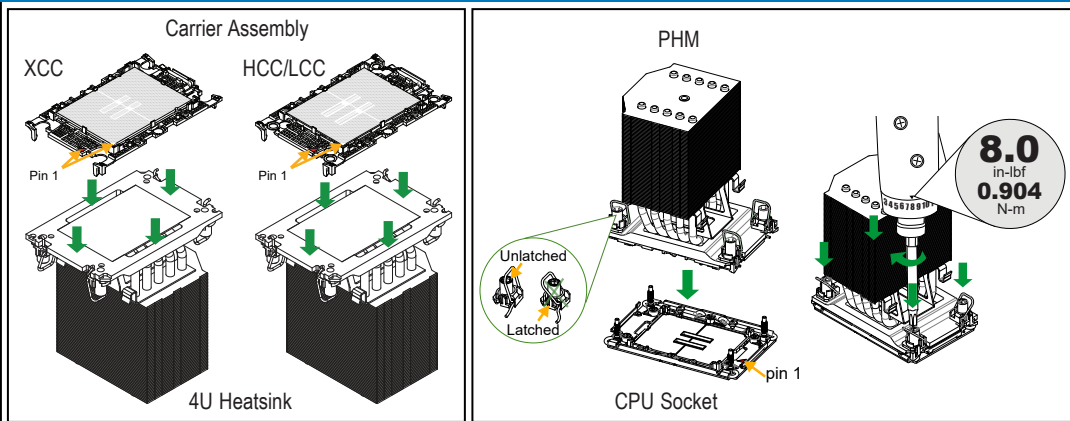

Rear I/O Ports

1. COM Port	8. USB4: USB 3.2 Gen 2x1 Port (10 Gb, Type-A)
2. VGA Port (supported by BMC, X14SRA-F only)	9. USB5: USB 3.2 Gen 2x1 Port (10 Gb, Type-A)
3. LAN1: RJ45 1 GbE LAN Port (shared BMC LAN port, X14SRA-F only)	10. USB8: USB 3.2 Gen 2x2 Port (20 Gb, Type-C)
4. LAN2: RJ45 1 GbE LAN Port	11. Line In
5. USB6: USB 3.2 Gen 2x1 Port (10 Gb, Type-A)	12. Line Out
6. USB7: USB 3.2 Gen 2x1 Port (10 Gb, Type-A)	13. Mic In
7. LAN3: RJ45 10 GbE LAN Port (X14SRA-T only)	14. UID Switch (X14SRA-F only)

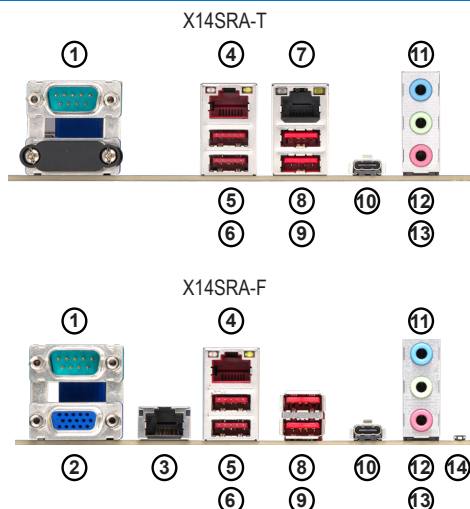

主機板元件配置圖

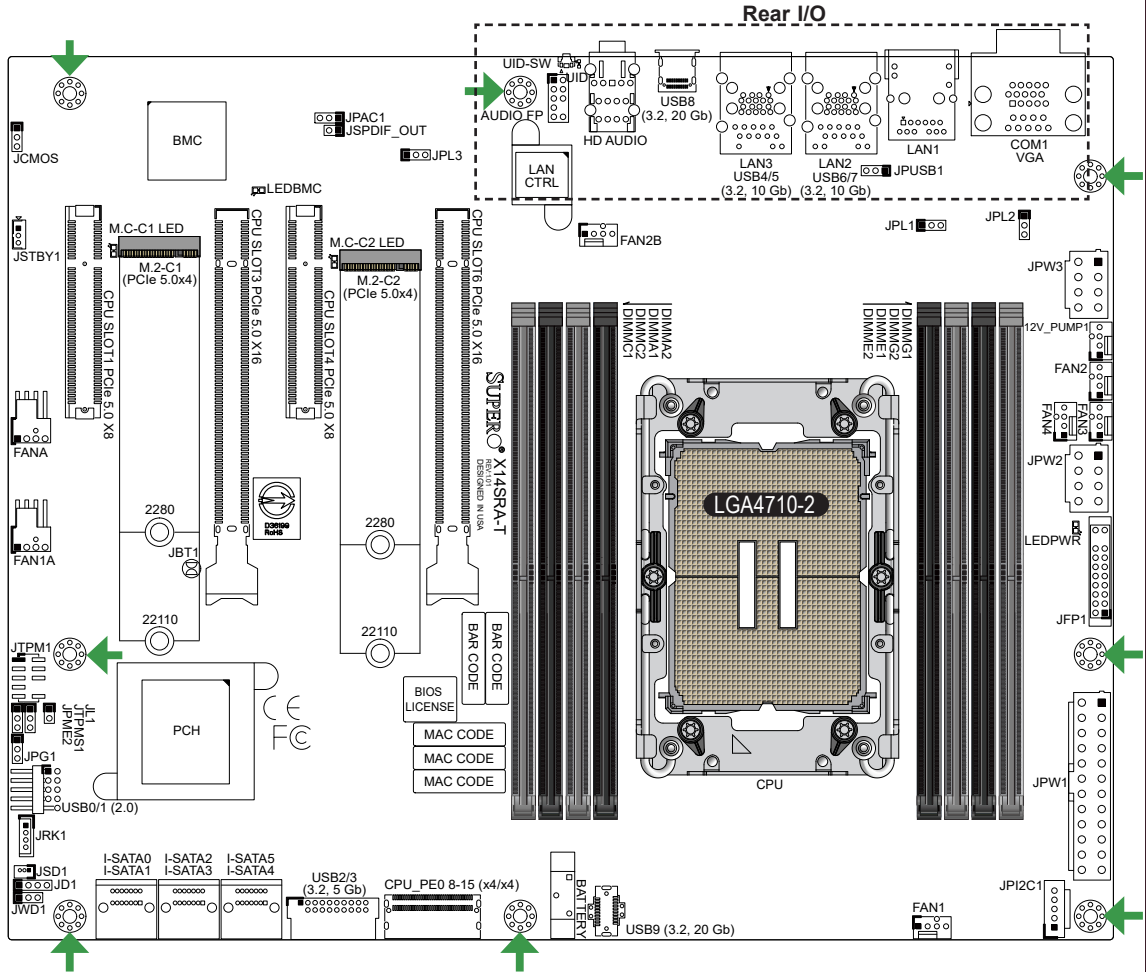

X14SRA-T 和 X14SRA-F 背板輸出/輸入連接埠差異

	X14SRA-T	X14SRA-F
LAN1 : RJ45 1 GbE LAN 網路連接埠	無	有
LAN3 : RJ45 10 GbE LAN 網路連接埠	有	無
單位識別按鈕	無	有
VGA 連接埠	無	有

➔ = 裝機孔

單一主機板包裝盒內容清單

- Supermicro 主機板 x1
- 快速參考指南 x1
- 後擋板 x1
- SATA 訊號線 x6
- E2A 處理器托架 (適用 Intel Xeon 600 系列 XCC 處理器) x1
- E2B 處理器托架 (適用 Intel Xeon 600 系列 HCC/LCC 處理器) x1

LED 指示燈/連接埠

LED 指示燈		
LED	說明	燈號顏色及狀態
LEDBMC	BMC 運作指示燈 (僅限 X14SRA-F)	綠燈閃爍：BMC 正常運作
LEDPWR	內建電源指示燈	綠燈恆亮：開啟
M.C-C1 LED, M.C-C2 LED	分別代表 M.2-C1/M.2-C2 的 M.2 裝置指示燈	綠燈閃爍：M.2 裝置使用中
UID	單位識別指示燈 (僅限 X14SRA-F)	藍燈恆亮：識別中

連接埠 (Connector)	
連接埠	說明
12V_PUMP1	+12 V 4針腳 水冷幫浦電源插座
AUDIO FP	前面板音效接頭
BATTERY	內建電池
COM1	背板 COM 序列連接埠
CPU_PE0 8-15 (x4/x4)	PCIe 5.0 x8 MCIO 連接埠 · 支援兩個 U.2 儲存裝置 (源自 CPU、支援 RAID 0/1)
FAN1-FAN4	中央處理器 (CPU) 風扇接頭
FANA, FAN1A, FAN2B	系統風扇接頭
HD AUDIO	背板高清晰音效插孔
I-SATA0-I-SATA5	Intel SATA 3.0 連接埠 (源自 PCH、6 Gbps、支援 RAID 0/1/5/10)
JD1	外接喇叭/蜂鳴器接頭
JFP1	前控制面板接頭
JL1	機殼防盜裝置接頭
JPI2C1	電源供應 SMBus I2C 接頭 (僅限 X14SRA-F)
JPW1	24針腳 ATX 主電源連接埠 (必備)
JPW2, JPW3	+12 V 8針腳 CPU 電源連接埠
JRK1	Intel VROC RAID Key 接頭 * 啟用 M.2 RAID 功能需加裝 VROC hardware key。
JSD1	SATA Disk-On-Module (DOM) 磁碟模組電源連接埠
JSPDIF_OUT	S/PDIF (索尼/飛利浦數位傳輸介面) 輸出接頭
JSTBY1	待機電源接頭 (5 V)
JTPM1	TPM 信任平台模組 / Port 80 接頭 (僅支援 TPM 2.0)
LAN1	RJ45 1 GbE 網路連接埠 (BMC 共享網路連接埠、僅限 X14SRA-F)
LAN2	RJ45 1 GbE 網路連接埠 (支援 Intel vPro®)
LAN3	RJ45 10 GbE 網路連接埠 (僅限 X14SRA-T)
M.2-C1, M.2-C2	PCIe 5.0 x4 M.2 M-key 裝置連接埠 (源自 CPU、支援 2280/22110 尺寸 M.2 模組規格、RAID 0/1)
SLOT1, SLOT4	PCIe 5.0 x8 插槽 (源自 CPU)
SLOT3, SLOT6	PCIe 5.0 x16 插槽 (源自 CPU)
UID-SW	單位識別按鈕 (僅限 X14SRA-F)
USB0/1	前面板 USB 2.0 規格接頭
USB2/3	前面板 USB 3.2 Gen 1 規格接頭 (5 Gb, Type-A)
USB4/5	背板 USB 3.2 Gen 2x1 規格連接埠 (10 Gb, Type-A)
USB6/7	背板 USB 3.2 Gen 2x1 規格連接埠 (10 Gb, Type-A)
USB8	背板 USB 3.2 Gen 2x2 規格連接埠 (20 Gb, Type-C)
USB9	前面板 USB 3.2 Gen 2x2 規格接頭 (20 Gb, Type-C)
VGA	VGA 連接埠源自 BMC (僅限 X14SRA-F)

線上技術支援及下載

- 聯絡我們 (技術支援信箱) : www.supermicro.com (Email: support@supermicro.com)
- 產品手冊文件 : <https://www.supermicro.com/support/manuals>
- 驅動程式及工具程式 : <https://www.supermicro.com/wdl/driver/>
- 產品安全性須知 : https://www.supermicro.com/about/policies/safety_information.cfm

跳線器

跳線器 (Jumper)

跳線器	說明	預設值
JBT1	(板上) CMOS 組態資料清除	設為短路清除 CMOS 資料
JCMOS	(板上) CMOS 組態資料清除	針腳 1-2 (正常)
JPAC1	正常/停用音源	針腳 1-2 (正常)
JPG1	BMC VGA 功能 (僅限 X14SRA-F)	針腳 1-2 (啟用)
JPL1	啟用/停用 LAN1 (僅限 X14SRA-F)	針腳 1-2 (啟用)
JPL2	啟用/停用 LAN2	針腳 1-2 (啟用)
JPL3	啟用/停用 LAN3 (僅限 X14SRA-T)	針腳 1-2 (啟用)
JPME2	Intel 製造模式	針腳 1-2 (正常)
JPUSB1	USB6/7 待機電源	針腳 1-2 (啟用)
JTPMS1	TPM 信任平台模組切換 (板上/接頭)	針腳 1-2 : 板上 TPM 信任平台模組 (預設值) 針腳 2-3 : TPM 信任平台模組接頭 / Port 80 接頭
JWD1	啟用系統監控 (Watchdog) 功能	針腳 1-2 (重設)

中央處理器和記憶體支援

主機板 X14SRA-T/X14SRA-F 支援單顆 Intel Xeon 600 系列處理器 (LGA4710-2/Socket E2)。配有的八根 DDR5 記憶體插槽支援 1 TB ECC RDIMM 及 2 TB ECC 3DS RDIMM。傳輸速度最高可達 6400 MT/s (1DPC)、5200 MT/s (2DPC)、或支援 256 GB ECC MRDIMM。傳輸速度最高可達 8000 MT/s (1DPC)。

欲取得雙通道效能，請安裝成對相同型號與速度的記憶體。

註：1) 請安裝使用本公司所認可的記憶體模組以達記憶體模組最佳化。更多的記憶體模組相關訊息，請參閱本公司網頁 <https://www.supermicro.com/products/motherboard>。

2) 增加、移除和更換任何硬體元件前，請務必先拔掉電源線。待確實完成所有程序後，再重新連接電源線。

3) DDR 為「雙倍速動態隨機存取記憶體」；ECC 是 Error Correction Code 的縮寫，中譯為「錯誤修正碼」。

記憶體模組 (DIMM) 安裝

請依以下說明安裝記憶體模組：

- 請使用相同型號與速度的記憶體 (DDR5)。
- 若混合使用不同速度的記憶體，系統將依較低的記憶體速度執行。
- 安裝記憶體模組時，請先安裝該通道 (channel) 的灰色插槽，黑色插槽才能發揮效能。
- DDR5 記憶體模組不可熱插拔，在安裝或取出前請務必斷開電源至少二十秒。
- 傾斜拆卸會導致 DDR5 記憶體模組損壞。請以垂直向上方式將記憶體模組從插槽中取出。

此面向向中央處理器 →

← 此面向向中央處理器



備註

- 快速參考指南中，圖例僅供安裝及操作說明使用，可能與實際產品外觀不同。
- 欲知更多跳線器/連接埠/指示燈/記憶體/主機板/中央處理器安裝相關資訊，請參閱使用手冊。

中央處理器安裝

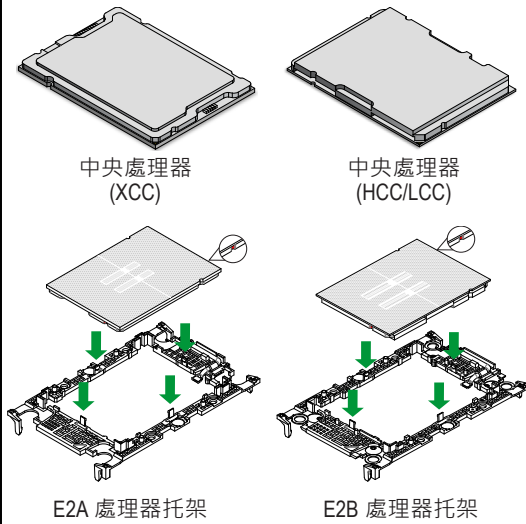

前控制面板配置 (JFP1)

	20	19	
接地	○	○	非可遮蔽中斷
無連接	○	○	無連接
前控制面板電源指示燈	○	○	+3.3 V 待機電源
硬碟指示燈	○	○	+3.3 V 待機電源 (X14SRA-T) 單位識別按鈕 (X14SRA-F)
網卡1 指示燈	○	○	+3.3 V 待機電源
網卡2 指示燈	○	○	+3.3 V 待機電源
過熱/風扇故障/電源故障指示燈	○	○	無連接 (X14SRA-T) 單位識別指示燈 (X14SRA-F)
無連接 (X14SRA-T) 電源故障指示燈 (X14SRA-F)	○	○	+3.3 V 電源
接地	○	○	重設 重設鍵
接地	○	○	電源 電源鍵
	2	1	

處理器散熱模組 (PHM) 安裝

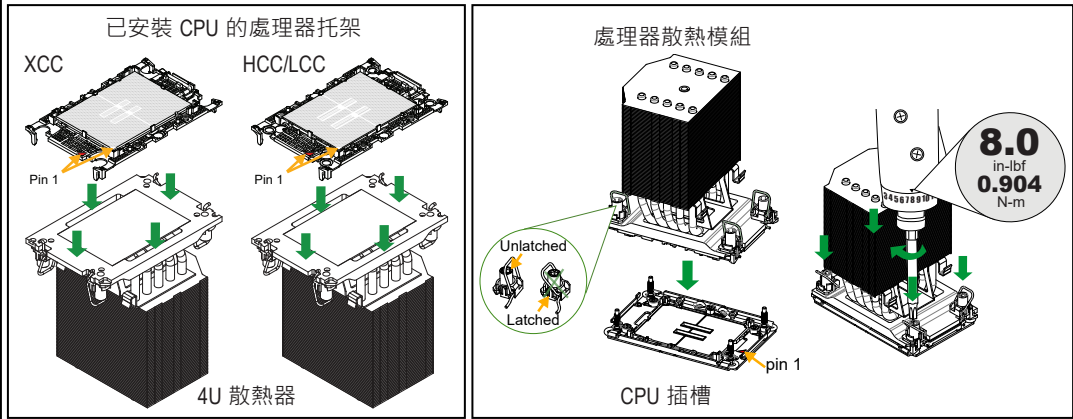

背板輸出/輸入裝置連接埠

1. COM 連接埠	8. USB4 : USB 3.2 Gen 2x1 規格連接埠 (10 Gb, Type-A)
2. VGA 連接埠 (源自 BMC、僅限 X14SRA-F)	9. USB5 : USB 3.2 Gen 2x1 規格連接埠 (10 Gb, Type-A)
3. LAN1 : RJ45 1 GbE 網路連接埠 (BMC 共享網路連接埠、僅限 X14SRA-F)	10. USB8 : USB 3.2 Gen 2x2 規格連接埠 (20 Gb, Type-C)
4. LAN2 : RJ45 1 GbE 網路連接埠	11. 音效輸入
5. USB6 : USB 3.2 Gen 2x1 規格連接埠 (10 Gb, Type-A)	12. 音效輸出
6. USB7 : USB 3.2 Gen 2x1 規格連接埠 (10 Gb, Type-A)	13. 麥克風插孔
7. LAN3 : RJ45 10 GbE 網路連接埠 (僅限 X14SRA-T)	14. 單位識別按鈕 (僅限 X14SRA-F)

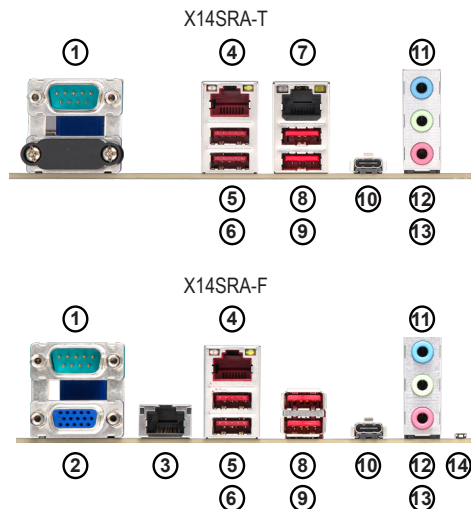

MNL-2802-QRG-10a

主板布局和功能

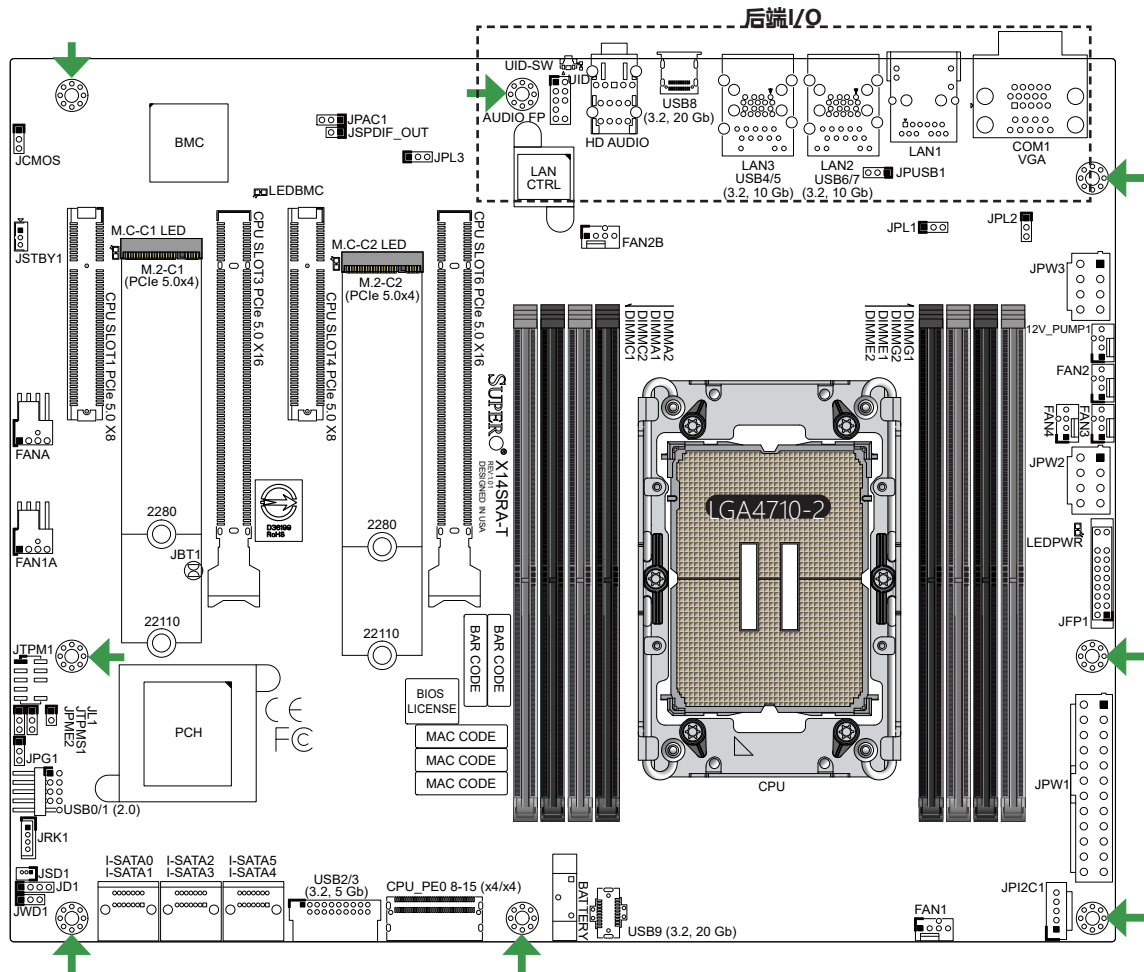

X14SRA-T 和 X14SRA-F 后板 I/O 差异

	X14SRA-T	X14SRA-F
LAN1: RJ45 1 GbE LAN 端口	不适用	是
LAN3: RJ45 10 GbE LAN 端口	是	不适用
UID 开关	不适用	是
VGA 端口	不适用	是

➔ = 安装孔

包装内容

- Supermicro 主板 x1
- 快速参考指南 x1
- I/O 扩展板 x1
- SATA 连接线 x6
- CPU 托架 E2A x1, 用于 Intel Xeon 600 系列 XCC 处理器
- CPU 托架 E2B x1, 用于 Intel Xeon 600 系列 HCC/LCC 处理器

LED 指示器和接口

LED 指示器		
LED	说明	颜色/状态
LEDBMC	BMC 心跳 LED (仅限 X14SRA-F)	闪烁绿灯: BMC 正常
LEDPWR	板载电源 LED	绿灯保持亮起: 开机
M.C-C1 LED, M.C-C2 LED	M.2 LED 适用于 M.2-C1/M.2-C2	闪烁绿灯: 设备工作中
UID	装置标识符 (UID) LED (仅限 X14SRA-F)	蓝灯保持亮起: 设备已识别

接口	
接口	说明
12V_PUMP1	+12 V 4针电源接口 (用于 CPU 液冷泵)
AUDIO FP	前面板音频插座
BATTERY	板载电池
COM1	后端 COM 端口
CPU_PE0 8-15 (x4/x4)	支持两个 U.2 连接的 PCIe 5.0 x8 MCIO 接口 (来自 CPU, 支持 RAID 0/1)
FAN1-FAN4	CPU 风扇插座
FANA、FAN1A、FAN2B	系统风扇插座
HD AUDIO	后面高清音频端口
I-SATA0-I-SATA5	Intel SATA 3.0 端口 (来自 PCH, 6 Gbps, 支持 RAID 0/1/5/10)
JD1	外部扬声器/蜂鸣器插座
JFP1	前端控制面板插座
JL1	机箱侵入插座
JPI2C1	电源系统管理总线 (SMBus) I2C 插座 (仅限 X14SRA-F)
JPW1	24针 ATX 主电源接口 (必需)
JPW2、JPW3	+12 V 8针 CPU 电源接口
JRK1	Intel VROC RAID 密钥插座 * VROC RAID 功能需要 VROC 硬件密钥。
JSD1	SATA 模块上磁盘 (DOM) 电源接口
JSPDIF_OUT	Sony/Philips 数字接口 (S/PDIF) 输出插座
JSTBY1	备用电源插座 (5 V)
JTPM1	可信平台模块 (TPM)/端口 80 插座 (仅限 TPM 2.0)
LAN1	RJ45 1 GbE LAN 端口 (共享的 BMC LAN 端口, 仅限 X14SRA-F)
LAN2	RJ45 1 GbE LAN 端口 (支持 Intel vPro®)
LAN3	RJ45 10 GbE LAN 端口 (仅限 X14SRA-T)
M.2-C1、M.2-C2	PCIe 5.0 x4 M.2 M-key 插槽 (来自 CPU, 支持 2280/22110 规格和 RAID 0/1)
SLOT1、SLOT4	PCIe 5.0 x8 插槽 (来自 CPU)
SLOT3、SLOT6	PCIe 5.0 x16 插槽 (来自 CPU)
UID-SW	装置标识符 (UID) 开关 (仅限 X14SRA-F)
USB0/1	前置 USB 2.0 插座
USB2/3	前置 USB 3.2 Gen 1 插座 (5 Gb, Type-A)
USB4/5	后端 USB 3.2 Gen 2x1 端口 (10 Gb, Type-A)
USB6/7	后端 USB 3.2 Gen 2x1 端口 (10 Gb, Type-A)
USB8	后端 USB 3.2 Gen 2x2 端口 (20 Gb, Type-C)
USB9	前置 USB 3.2 Gen 2x2 插座 (20 Gb, Type-C)
VGA	BMC 支持的 VGA 端口 (仅限 X14SRA-F)

联系信息

- www.supermicro.com (Email: support@supermicro.com)
- 产品手册文件: <https://www.supermicro.com/support/manuals>
- 驱动程序及工具: <https://www.supermicro.com/wdl/driver/>
- 产品安全性须知: https://www.supermicro.com/about/policies/safety_information.cfm

跳线

跳线		
跳线	说明	默认设置
JBT1	清除 CMOS 信息 (板载)	清除 CMOS 信息的短接焊盘
JCMOS	清除 CMOS 信息 (板载)	针脚1-2 (正常)
JPAC1	高清音频正常/禁用	针脚1-2 (正常)
JPG1	BMC VGA 功能 (仅限 X14SRA-F)	针脚1-2 (已启用)
JPL1	LAN1 启用/禁用 (仅限 X14SRA-F)	针脚1-2 (已启用)
JPL2	LAN2 启用/禁用	针脚1-2 (已启用)
JPL3	LAN3 启用/禁用 (仅限 X14SRA-F)	针脚1-2 (已启用)
JPME2	Intel 制造模式	针脚1-2 (正常)
JPUSB1	USB6/7 待机功率	针脚1-2 (已启用)
JTPMS1	TPM 选择 (板载/插座)	针脚1-2: 板载 TPM (默认) 针脚2-3: TPM 插座/端口 80 插座
JWD1	看门狗功能启用	针脚1-2 (重置)

CPU 和内存支持

X14SRA-T/X14SRA-F 主板支持单个 Intel Xeon 600 系列处理器 (LGA4710-2/Socket E2)。八个 DDR5 内存插槽最大支持内存为 1 TB ECC RDIMM 和 2 TB ECC 3DS RDIMM, 最高速度 6400 MT/s (1DPC) 或 5200 MT/s (2DPC), 以及 256 GB ECC MRDIMM, 最高速度 8000 MT/s (1DPC)。

在这些 DIMM 插槽中安装一对相同类型和大小的内存模块将产生交错内存, 这将提高内存性能。

备注: 1) 要进行内存优化, 请仅使用经 Supermicro 验证的 DIMM 模块。有关最新内存更新, 请参阅我们的网站 <https://www.supermicro.com/products/motherboard>。

2) 最后连接电源线, 并在添加、移除或更换任何硬件组件之前始终将其断开。

DIMM 内存安装

内存安装指南

- 建议使用大小、类型和速度相同的 DDR5 DIMM 模块。
- 可安装混合 DIMM 速度。但所有 DIMM 将会以最慢的 DIMM 速度运行。
- 指定通道中, 仅在灰色插槽首先已安装时才能启用黑色插槽。
- DDR5 DIMM 模块不可热插拔, 插入或取下之前, 请确保断开电源至少 20 秒。
- 倾斜取下 DDR5 DIMM 模块会导致损坏。强烈建议直接将模块从插槽中提起。



备注

- 此快速参考索引中显示的图片，仅用于图示目的。您的组件可能和或不与此索引中显示的图片完全相同。
- 有关跳线、接口、LED指示灯、内存支持和CPU/主板安装说明的详细信息，请参阅《用户手册》。

CPU 安装

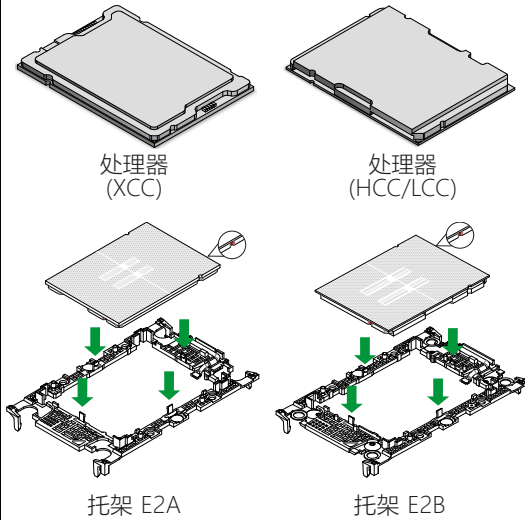

前面控制面板 (JFP1)

	20	19	
GND	○	○	NMI
NC	○	○	NC
FP电源LED	○	○	+3.3 V 待机
硬盘LED	○	○	+3.3 V 待机 (X14SRA-T) UID SW (X14SRA-F)
NIC1 LED	○	○	+3.3 V 待机
NIC2 LED	○	○	+3.3 V 待机
OH/风扇故障/电源故障LED	○	○	NC (X14SRA-T) UID LED (X14SRA-F)
NC (X14SRA-T) 电源故障 LED (X14SRA-F)	○	○	+3.3 V
GND	○	○	重置 } 重置按钮
GND	○	○	
	2	1	

(NC=无连接)

处理器散热器模块 (PHM) 安装

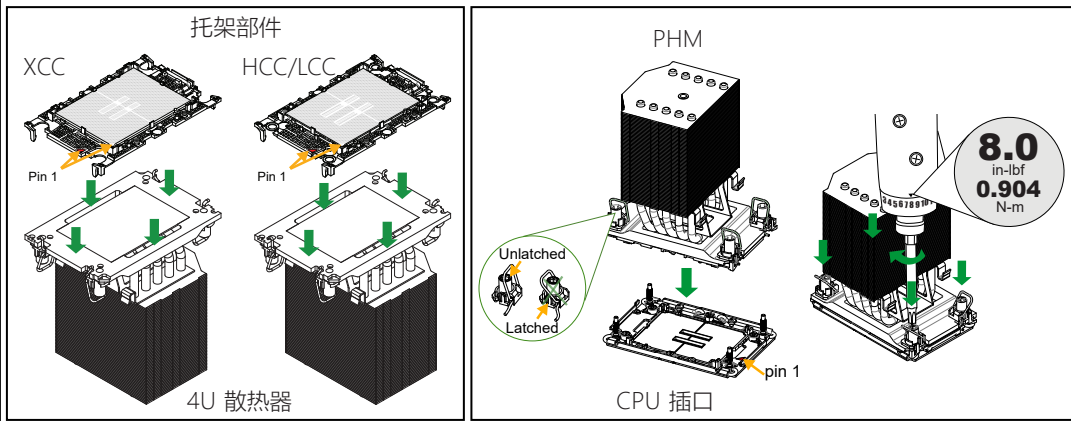

后端 I/O 接口

1. COM 端口	8. USB4: USB 3.2 Gen 2x1 端口 (10 Gb, Type-A)	X14SRA-T			
2. BMC 支持的 VGA 端口 (仅限 X14SRA-F)	9. USB5: USB 3.2 Gen 2x1 端口 (10 Gb, Type-A)	①	④	⑦	⑪
3. LAN1: RJ45 1 GbE LAN 端口 (共享的 BMC LAN 端口, 仅限 X14SRA-F)	10. USB8: USB 3.2 Gen 2x2 端口 (20 Gb, Type-C)				
4. LAN2: RJ45 1 GbE LAN 端口	11. 线路输入	⑤	⑧	⑩	⑫
5. USB6: USB 3.2 Gen 2x1 端口 (10 Gb, Type-A)	12. 线路输出	⑥	⑨	⑬	⑬
6. USB7: USB 3.2 Gen 2x1 端口 (10 Gb, Type-A)	13. 麦克风输入	X14SRA-F			
7. LAN3: RJ45 10 GbE LAN 端口 (仅限 X14SRA-T)	14. UID 开关 (仅限 X14SRA-F)	①	④	⑪	⑪
		②	③	⑤	⑧
		⑥	⑨	⑩	⑫
					⑬

MNL-2802-QRG-10a

© 2026 美超微股份有限公司 (以下简称「本公司」) 版权所有。未经本公司书面同意，严禁重製本文件部分或全部内容。所有商標均為所屬公司所有。所有提供資訊均印刷之際被認為但不保證正確。

マザーボードのレイアウトと機能

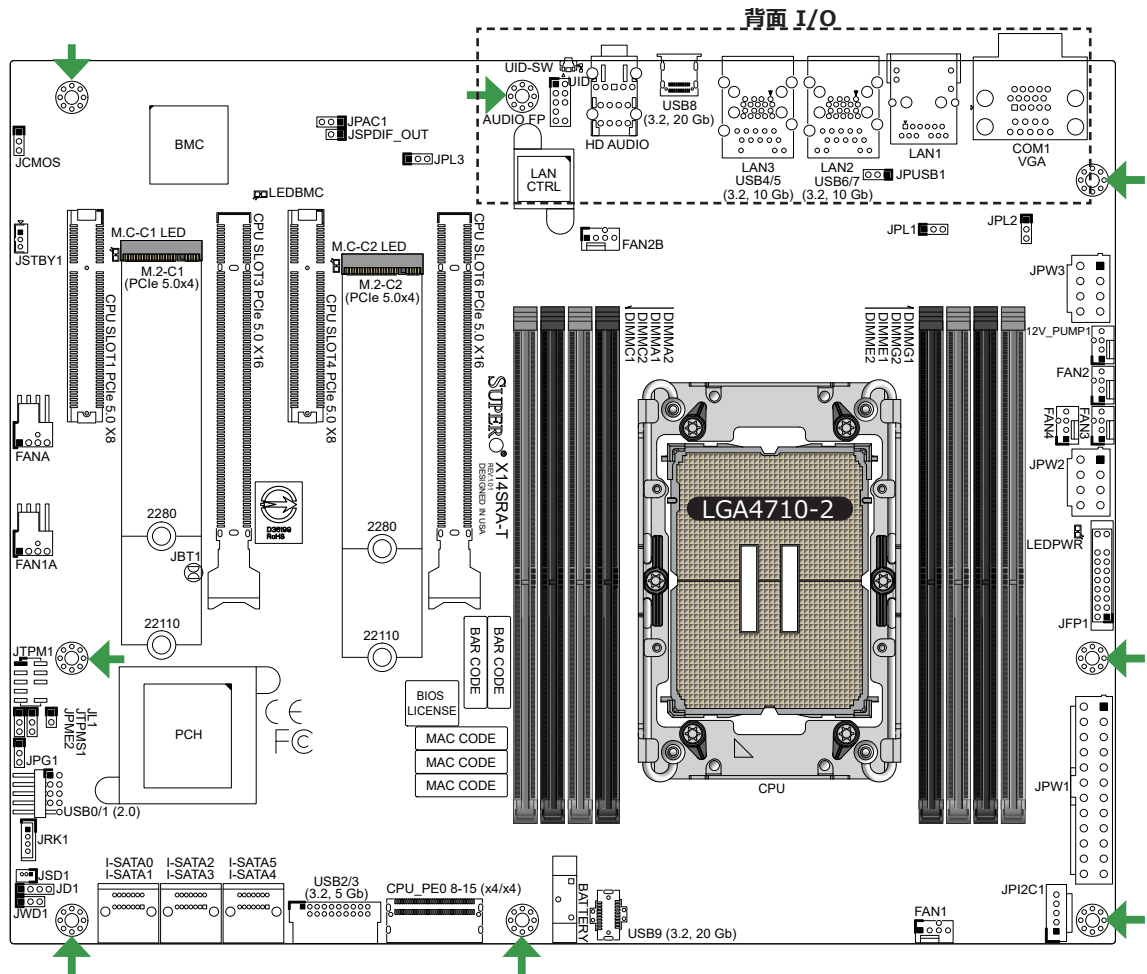

X14SRA-T と X14SRA-F の背面 I/O の違い

	X14SRA-T	X14SRA-F
LAN1 : RJ45 1 GbE LAN ポート	なし	あり
LAN3 : RJ45 10 GbE LAN ポート	あり	なし
UID スイッチ	なし	あり
VGA ポート	なし	あり

➡ = 取り付け穴

パッケージ内容

- Supermicro マザーボード 1枚
- クイックリファレンスガイド 1冊
- I/O シールド 1個
- SATA ケーブル 6本
- CPU キャリア E2A 1個 Intel Xeon 600 シリーズ XCC プロセッサ用
- CPU キャリア E2B 1個 Intel Xeon 600 シリーズ HCC/LCC プロセッサ用

LED インジケータとコネクタ

LED インジケータ

LED	説明	カラー/状態
LEDBMC	BMC ハートビート LED (X14SRA-F のみ)	緑色に点滅: BMC ノーマル
LEDPWR	基板上的電源 LED	緑色に点灯: 電源オン
M.C-C1 LED, M.C-C2 LED	M.2-C1/M.2-C2 用 M.2 LED	緑色に点滅: デバイス作動中
UID	ユニット ID (UID) LED (X14SRA-F のみ)	青色に点灯: ユニートを識別済み

コネクタ

コネクタ	説明
12V_PUMP1	+12 V 4 ピン電源コネクタ (CPU 水冷ポンプ用)
AUDIO FP	フロントパネル オーディオヘッダー
BATTERY	オンボードバッテリー
COM1	背面 COM ポート
CPU_PE0 8-15 (x4/x4)	PCIe 5.0 x8 MCIO コネクタ, 2つの U.2 接続をサポート (CPU 側, RAID 0/1 をサポート)
FAN1-FAN4	CPU ファンヘッダー
FANA, FAN1A, FAN2B	システムファンヘッダー
HD AUDIO	背面ハイデフィニション オーディオポート
I-SATA0-I-SATA5	Intel SATA 3.0 ポート (PCH 側, 6 Gbps, RAID 0/1/5/10 をサポート)
JD1	外部スピーカー/ブザー ヘッダー
JFP1	フロント コントロールパネル ヘッダー
JF1	シャーシインテリジョンヘッダー
JPI2C1	電源システム管理バス (SMBus) I2C ヘッダー (X14SRA-F のみ)
JPW1	24ピン ATX 主電源コネクタ (必須)
JPW2, JPW3	+12 V 8ピン CPU 電源コネクタ
JRK1	Intel VROC RAID キー ヘッダー * VROC ハードウェア キーには VROC RAID 機能が必要です。
JSD1	SATA Disk-On-Module (DOM) 電源コネクタ
JSPDIF_OUT	Sony/Philips デジタルインターフェース (S/PDIF) 出力ヘッダー
JSTBY1	スタンバイ電源ヘッダー (5 V)
JTPM1	Trusted Platform Module (TPM) / ポート 80 ヘッダー (TPM 2.0 のみ)
LAN1	RJ45 1 GbE LAN ポート (共有 BMC LAN ポート, X14SRA-F のみ)
LAN2	RJ45 1 GbE LAN ポート (Intel vPro® をサポート)
LAN3	RJ45 10 GbE LAN ポート (X14SRA-T のみ)
M.2-C1, M.2-C2	PCIe 5.0 x4 M.2 M キーソケット (CPU 側, 2280/22110 フォームファクタおよび RAID 0/1 をサポート)
SLOT1, SLOT4	PCIe 5.0 x8 スロット (CPU 側)
SLOT3, SLOT6	PCIe 5.0 x16 スロット (CPU 側)
UID-SW	ユニット ID (UID) スイッチ (X14SRA-F のみ)
USB0/1	フロントアクセス可能 USB 2.0 ヘッダー
USB2/3	フロントアクセス可能 USB 3.2 Gen 1 ヘッダー (5 Gb, タイプ A)
USB4/5	背面 USB 3.2 Gen 2x1 ポート (10 Gb, タイプ A)
USB6/7	背面 USB 3.2 Gen 2x1 ポート (10 Gb, タイプ A)
USB8	背面 USB 3.2 Gen 2x2 ポート (20 Gb, タイプ C)
USB9	フロントアクセス可能 USB 3.2 Gen 2x2 ヘッダー (20 Gb, タイプ C)
VGA	BMC でサポートされる VGA ポート (X14SRA-F のみ)

お問い合わせ先

- www.supermicro.com (電子メール : support@supermicro.com)
- マニュアル : <https://www.supermicro.com/support/manuals>
- ドライバー & ユーティリティ : <https://www.supermicro.com/wdl/driver/>
- 安全性 : https://www.supermicro.com/about/policies/safety_information.cfm

ジャンパー

ジャンパー

ジャンパー	説明	デフォルト設定
JBT1	CMOS クリア (基板上)	CMOS クリア用の短いパッド
JCMOS	CMOS クリア (基板上)	ピン 1-2 (ノーマル)
JPAC1	HD オーディオ ノーマル/無効化	ピン 1-2 (ノーマル)
JPG1	BMC VGA 機能 (X14SRA-F のみ)	ピン 1-2 (有効)
JPL1	LAN1 有効化/無効化 (X14SRA-F のみ)	ピン 1-2 (有効)
JPL2	LAN2 有効化/無効化	ピン 1-2 (有効)
JPL3	LAN3 有効化/無効化 (X14SRA-T のみ)	ピン 1-2 (有効)
JPME2	Intel マニファクチャーモード	ピン 1-2 (ノーマル)
JPUSB1	USB6/7 スタンバイ電源	ピン 1-2 (有効)
JTPMS1	TPM 選択 (オンボード/ヘッダー)	ピン 1-2 : オンボード TPM (デフォルト) ピン 2-3 : TPM ヘッダー / ポート 80 ヘッダー
JWD1	ウォッチドッグ機能の有効化	ピン 1-2 (リセット)

CPU およびメモリサポート

X14SRA-T/X14SRA-F マザーボードは、単一の Intel Xeon 600 シリーズプロセッサをサポートします (LGA4710-2/Socket E2)。8 個の DDR5 メモリスロットは、最大 6400 MT/s (1DPC)または 5200 MT/s (2DPC) の速度で、最大 1 TB の ECC RDIMM と 2 TB の ECC 3DS RDIMM、および最大 8000 MT/s (1DPC) の速度で、256 GB の ECC MRDIMM をサポートします。

これらの DIMM スロットにタイプとサイズが同じメモリモジュールのペアを装着した場合、インターリーブメモリが生成されてメモリパフォーマンスが向上します。

注記 : 1 メモリの最適化には、Supermicro によって検証済みの DIMM モジュールのみを使用してください。最新のメモリアップデートについては、当社のウェブサイト (<https://www.supermicro.com/products/motherboard>) を参照してください。

- 2) 電源コードは必ず最後につけてください。ハードウェアコンポーネントを追加、取り外し、または変更する前には必ず抜いてください。

DIMM メモリ設置

メモリモジュール取付ガイドライン

- サイズ、タイプ、および速度が同じ DDR5 DIMM モデルの使用を推奨します。
- 異なる速度の DIMM を増設できます。ただしこの場合、すべての DIMM が最も遅い DIMM の速度で動作します。
- 特定のチャンネルでは、まず最初に灰色のスロットにメモリモジュールを実装することで、黒色のスロットが有効になります。
- DDR5 DIMM モジュールはホットスワップ対応ではないため、抜き差しする前に必ず 20 秒以上にわたって電源を切断するようにしてください。
- DDR5 DIMM モジュールを斜めに取り外すと、モジュールが破損します。モジュールをスロットからまっすぐ上に持ち上げることを強くお勧めします。

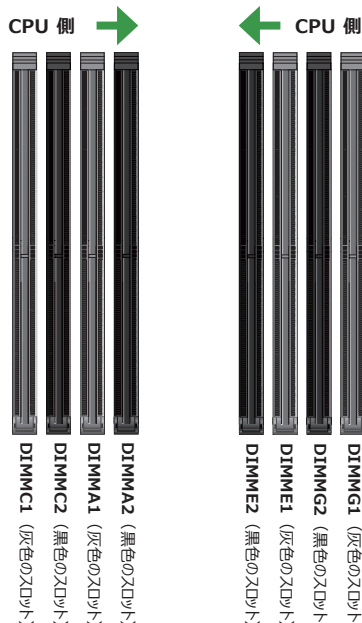

注記

- このクイックリファレンスガイドに掲載されている図は、説明のみを目的としています。本ガイドに記載されている図面とお客様のコンポーネントが全く同一であるとは限りません。
- ジャンパ、コネクタ、LED インジケータ、対応メモリ、および CPU / マザーボードの設置方法に関する詳細については、ユーザーマニュアルを参照してください。

CPUの設置

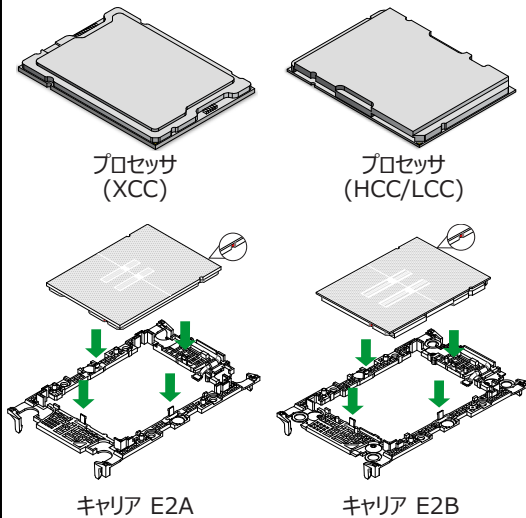

フロントコントロールパネル (JFP1)

	20	19	
グラウンド	○	○	NMI
NC	○	○	NC
FP 電源 LED	○	○	+3.3 V スタンバイ
HDD LED	○	○	+3.3 V スタンバイ (X14SRA-T) UID SW (X14SRA-F)
NIC1 LED	○	○	+3.3 V スタンバイ
NIC2 LED	○	○	+3.3 V スタンバイ
OH/ファン故障/電源故障 LED	○	○	NC (X14SRA-T) UID LED (X14SRA-F)
NC (X14SRA-T) 電源障害 LED (X14SRA-F)	○	○	+3.3V
グラウンド	○	○	リセット } リセットボタン 電源 } 電源ボタン
グラウンド	○	○	
	2	1	

(NC=接続なし)

プロセッサ ヒートシンク モジュール (PHM) の取り付け

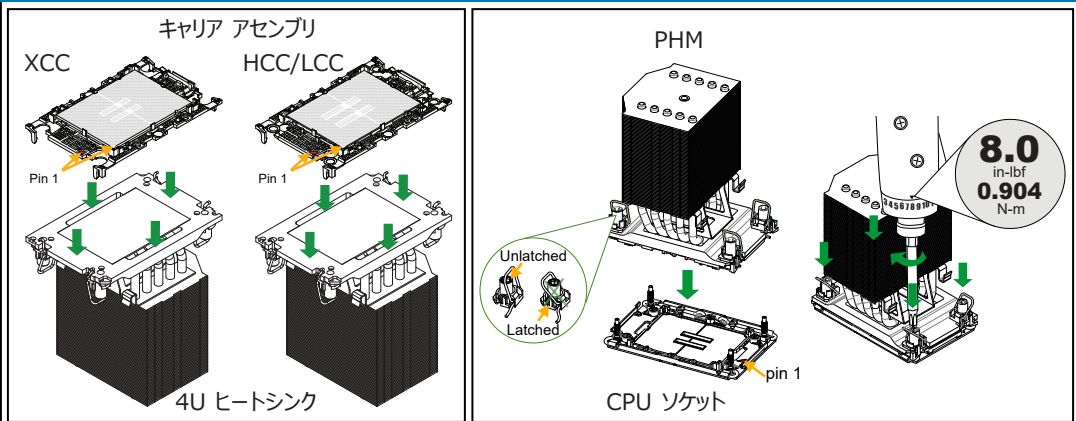

背面 I/O コネクタ

1. COM ポート	8. USB4 : USB 3.2 Gen 2x1 ポート (10 Gb、タイプ A)
2. VGA ポート (BMC でサポート、X14SRA-F のみ)	9. USB5 : USB 3.2 Gen 2x1 ポート (10 Gb、タイプ A)
3. LAN1 : RJ45 1 GbE LAN ポート (共有 BMC LAN ポート、X14SRA-F のみ)	10. USB8 : USB 3.2 Gen 2x2 ポート (20 Gb、タイプ C)
4. LAN2 : RJ45 1 GbE LAN ポート	11. ライン入力
5. USB6 : USB 3.2 Gen 2x1 ポート (10 Gb、タイプ A)	12. ライン出力
6. USB7 : USB 3.2 Gen 2x1 ポート (10 Gb、タイプ A)	13. マイク入力
7. LAN3 : RJ45 10 GbE LAN ポート (X14SRA-T のみ)	14. UID スイッチ (X14SRA-F のみ)

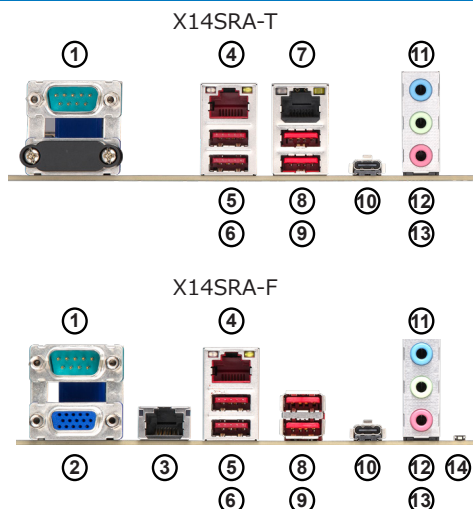

메인보드 레이아웃 및 특징

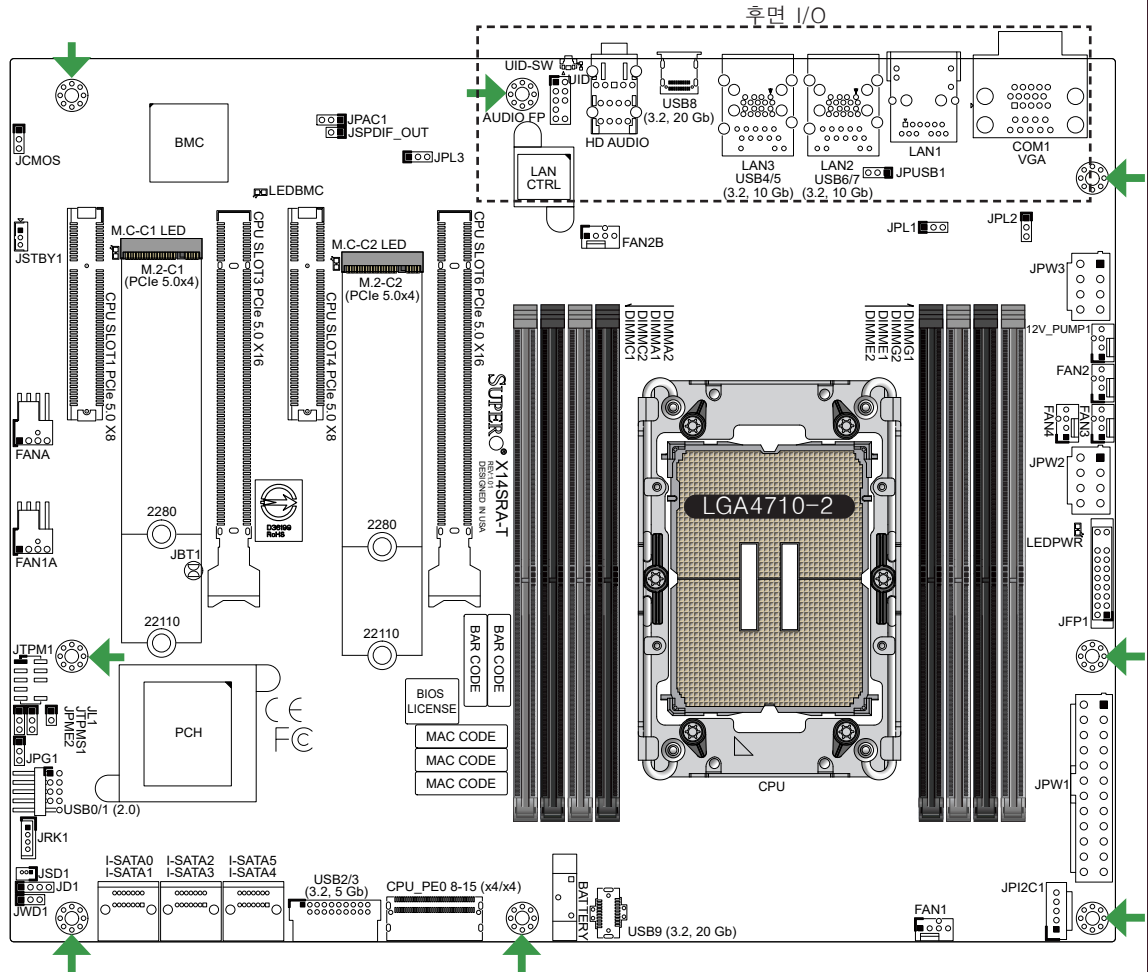

X14SRA-T 및 X14SRA-F의 후면 I/O 간의 차이점		
	X14SRA-T	X14SRA-F
LAN1: RJ45 1 GbE LAN 포트	해당사항 없음	예
LAN3: RJ45 10 GbE LAN 포트	예	해당사항 없음
UID 스위치	해당사항 없음	예
VGA 포트	해당사항 없음	예

➔ = 장착 구멍

패키지 내용물

- Supermicro 메인보드 1개
- SATA 케이블 6개
- 간편 가이드 1부
- CPU 캐리어 E2A 1개 (Intel Xeon 600 시리즈 XCC 프로세서용)
- I/O 쉴드 1개
- CPU 캐리어 E2B 1개 (Intel Xeon 600 시리즈 HCC/LCC 프로세서용)

LED 표시등 및 커넥터

LED 표시등		
LED	설명	색/상태
LEDBMC	BMC 하트비트 LED (X14SRA-F 전용)	녹색으로 깜박임: BMC 정상
LEDPWR	온보드 전원 LED	녹색으로 켜짐: 전원 켜기
M.C-C1 LED, M.C-C2 LED	M.2-C1/M.2-C2용 M.2 LED	녹색으로 깜박임: 장치 작동 중
UID	장치 식별자 (UID) LED (X14SRA-F 전용)	파란색으로 켜짐: 장치 식별됨

커넥터	
커넥터	설명
12V_PUMP1	+12 V 4핀 전원 커넥터 (CPU 수냉식 펌프용)
AUDIO FP	전면 패널 오디오 헤더
BATTERY	온보드 배터리
COM1	후면 COM 포트
CPU_PE0 8-15 (x4/x4)	U.2 연결 2개를 지원하는 PCIe 5.0 x8 MCIO 커넥터 (CPU에서, RAID 0/1 지원)
FAN1-FAN4	CPU 팬 헤더
FANA, FAN1A, FAN2B	시스템 팬 헤더
HD 오디오	후면 HD 오디오 포트
I-SATA0-I-SATA5	Intel SATA 3.0 포트 (PCH에서, 6 Gbps, RAID 0/1/5/10 지원)
JD1	외부 스피커/버저 헤더
JFP1	전면 제어 패널 헤더
JL1	새시 인트루전 헤더
JPI2C1	전원 공급장치 시스템 관리 버스 (SMBus) I2C 헤더 (X14SRA-F 전용)
JPW1	24핀 ATX 주전원 커넥터 (필수)
JPW2, JPW3	+12 V 8핀 CPU 전원 커넥터
JRK1	Intel VROC RAID 키 헤더 * VROC RAID 기능을 사용하려면 VROC 하드웨어 키가 필요합니다.
JSD1	SATA 디스크-온-모듈 (DOM) 전원 커넥터
JSPDIF_OUT	Sony/Philips 디지털 인터페이스 (S/PDIF) 출력 헤더
JSTBY1	대기 전력 헤더 (5 V)
JTPM1	신뢰할 수 있는 플랫폼 모듈 (TPM)/포트 80 헤더 (TPM 2.0만 지원)
LAN1	RJ45 1 GbE LAN 포트 (공유 BMC LAN 포트, X14SRA-F 전용)
LAN2	RJ45 1 GbE LAN 포트 (Intel vPro® 지원)
LAN3	RJ45 10 GbE LAN 포트 (X14SRA-T 전용)
M.2-C1, M.2-C2	PCIe 5.0 x4 M.2 M-key 슬롯 (CPU에서, 2280/22110 폼 팩터 및 RAID 0/1 지원)
SLOT1, SLOT4	PCIe 5.0 x8 슬롯 (CPU에서)
SLOT3, SLOT6	PCIe 5.0 x16 슬롯 (CPU에서)
UID-SW	장치 식별자 (UID) 스위치 (X14SRA-F 전용)
USB0/1	전면 액세스 가능 USB 2.0 헤더
USB2/3	전면 액세스 가능 USB 3.2 Gen 1 헤더 (5 Gb, 타입 A)
USB4/5	후면 USB 3.2 Gen 2x1 포트 (10 Gb, 타입 A)
USB6/7	후면 USB 3.2 Gen 2x1 포트 (10 Gb, 타입 A)
USB8	후면 USB 3.2 Gen 2x2 포트 (20 Gb, 타입 C)
USB9	전면 액세스 가능 USB 3.2 Gen 2x2 헤더 (20 Gb, 타입 C)
VGA	BMC에서 지원하는 VGA 포트 (X14SRA-F 전용)

연락처 정보

- www.supermicro.com (이메일: support@supermicro.com)
- 사용 설명서: <https://www.supermicro.com/support/manuals>
- 드라이버 및 유틸리티: <https://www.supermicro.com/wdl/driver/>
- 안전: https://www.supermicro.com/about/policies/safety_information.cfm

점퍼

점퍼		
점퍼	설명	기본 설정
JBT1	CMOS 초기화 (온보드)	CMOS 초기화용 쇼트 패드
JCMOS	CMOS 초기화 (온보드)	핀 1-2 (정상)
JPAC1	HD 오디오 정상/사용 안 함	핀 1-2 (정상)
JPG1	BMC VGA 기능 (X14SRA-F 전용)	핀 1-2 (사용)
JPL1	LAN1 사용/사용 안 함 (X14SRA-F 전용)	핀 1-2 (사용)
JPL2	LAN2 사용/사용 안 함	핀 1-2 (사용)
JPL3	LAN3 사용/사용 안 함 (X14SRA-T 전용)	핀 1-2 (사용)
JPME2	Intel ME 제조 모드	핀 1-2 (정상)
JPUSB1	USB6/7 대기 전원	핀 1-2 (사용)
JTPMS1	TPM 선택 (온보드/헤더)	핀 1-2: 온보드 TPM (기본값) 핀 2-3: TPM 헤더/포트 80 헤더
JWD1	Watchdog 기능 활성화	핀 1-2 (초기화)

CPU 및 메모리 지원

X14SRA-T/X14SRA-F 마더보드는 단일 Intel Xeon 600 시리즈 프로세서 (LGA4710-2/소켓 E2)를 지원합니다. DDR5 메모리 슬롯 8개는 속도가 최대 6400 MT/s (1DPC) 또는 5200 MT/s (2DPC)인 최대 1 TB의 ECC RDIMM 및 2 TB의 ECC 3DS RDIMM과 속도가 최대 8000 MT/s (1DPC)인 256 GB의 ECC MRDIMM을 지원합니다.

DIMM 슬롯에 동일한 유형 및 크기의 메모리 모듈 쌍을 채우면 인터리브 메모리가 발생하여 메모리 성능이 향상됩니다.

참고:1) 메모리 최적화를 위해 반드시 Supermicro의 인증을 받은 DIMM 모듈을 사용해야 합니다. 최신 메모리 업데이트는, 저희 웹사이트 <https://www.supermicro.com/products/motherboard>를 참조하세요.

2) 전원 코드는 반드시 마지막에 연결하고 하드웨어 구성품을 추가, 제거, 변경하기 전에는 반드시 전원 코드를 뽑아야 합니다.

DIMM 메모리 설치

메모리 설치 가이드라인

- 크기, 유형 및 속도의 DDR5 DIMM 모듈을 사용하는 것이 좋습니다.
- 혼합된 DIMM 속도를 설치해도 됩니다. 그러나 모든 DIMM가 가장 느린 DIMM 속도로 작동하게 됩니다.
- 채널에서 검은색 슬롯은 회색 슬롯이 처음으로 채워지는 경우에만 사용으로 설정할 수 있습니다.
- DDR5 DIMM 모듈은 핫스왑이 불가하며, 모듈을 삽입 또는 제거하기 전에 20초 이상 전원의 연결을 끊어야 합니다.
- DDR5 DIMM 모듈을 비스듬한 각도로 분리하면 손상이 발생합니다. 모듈을 슬롯에서 위 방향으로 똑바로 들어올리는 것이 좋습니다.

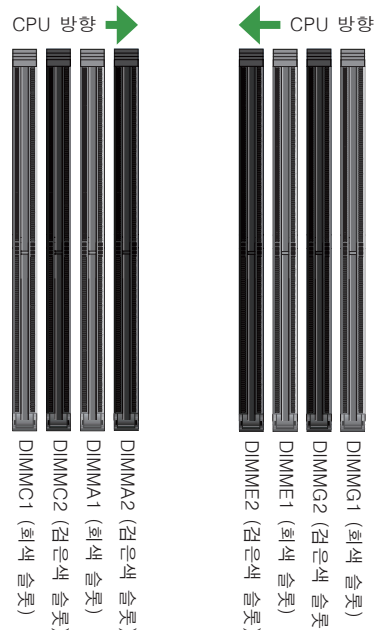

참고

- 이 간편 설명서의 그림들은 예시로만 사용됩니다. 실제 부품은 안내서에 표시된 도면과 동일하지 않을 수 있습니다.
- 접퍼, 커넥터, LED 표시등, 메모리 지원 및 CPU /메인보드 설치 지침에 대한 자세한 내용은 사용 설명서를 참조하십시오.

CPU 설치

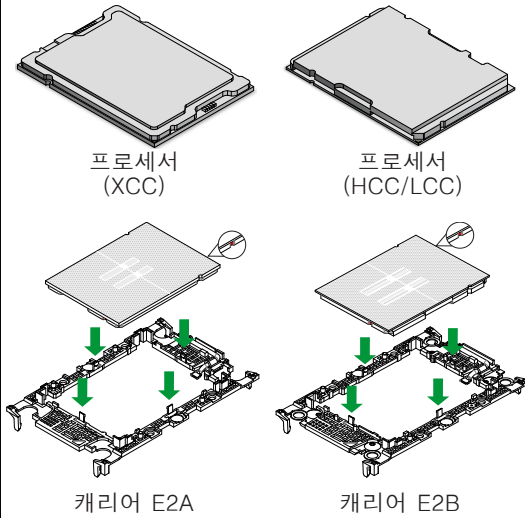

전면 제어 패널 (JFP1)

	20	19	
GND	○	○	NMI
NC	○	○	NC
FP 전력 LED	○	○	+3.3 V Stby
HDD LED	○	○	+3.3 V Stby(X14SRA-T) UID SW(X14SRA-F)
NIC1 LED	○	○	+3.3 V Stby
NIC2 LED	○	○	+3.3 V Stby
OH/팬 고장/전원 고장 LED	○	○	NC(X14SRA-T) UID LED(X14SRA-F)
NC(X14SRA-T) PWR 고장 LED(X14SRA-F)	○	○	+3.3V
GND	○	○	리셋 } 리셋 버튼
GND	○	○	PWR } 전원 버튼
	2	1	

(NC=연결 없음)

프로세서 방열판 모듈 (PHM) 설치

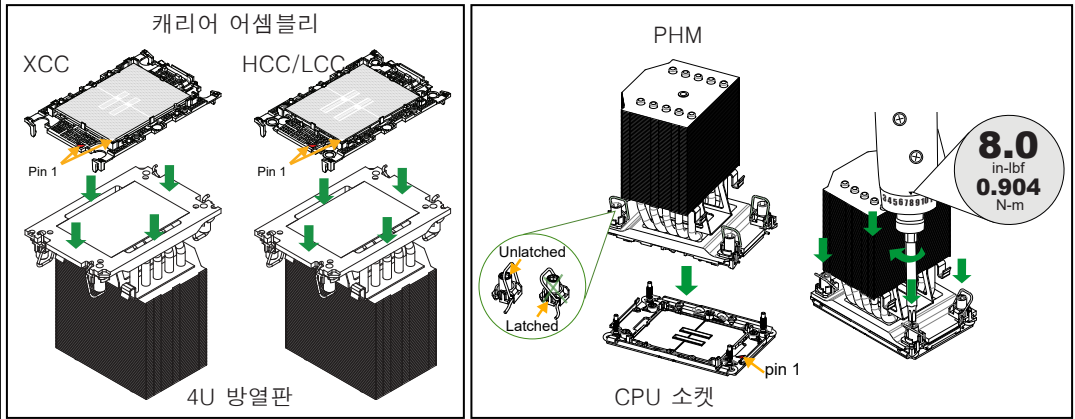

후면 I/O 커넥터

1. COM 포트	8. USB4: USB 3.2 Gen 2x1 포트 (10 Gb, 타입 A)
2. VGA 포트 (BMC에서 지원됨, X14SRA-F 전용)	9. USB5: USB 3.2 Gen 2x1 포트 (10 Gb, 타입 A)
3. LAN1: RJ45 1 GbE LAN 포트 (공유 BMC LAN 포트, X14SRA-F 전용)	10. USB8: USB 3.2 Gen 2x2 포트 (20 Gb, 타입 C)
4. LAN2: RJ45 1 GbE LAN 포트	11. 라인 입력
5. USB6: USB 3.2 Gen 2x1 포트 (10 Gb, 타입 A)	12. 라인 출력
6. USB7: USB 3.2 Gen 2x1 포트 (10 Gb, 타입 A)	13. 마이크 입력
7. LAN3: RJ45 10 GbE LAN 포트 (X14SRA-T 전용)	14. UID 스위치 (X14SRA-F 전용)

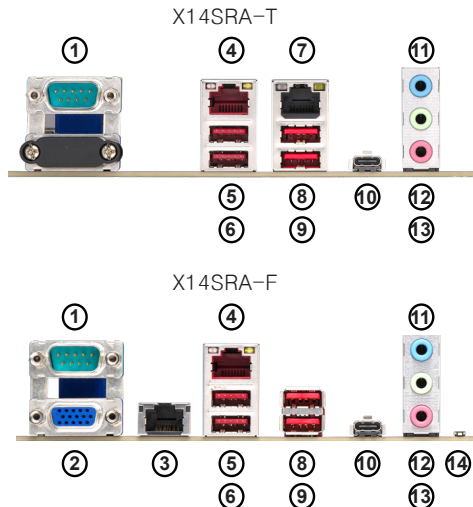

Notes

