



**SUPER**  <sup>TM</sup>

**Server Quality, Built for Gaming**

**C9Z590-CG**  
**C9Z590-CGW**

ENGLISH  
繁體中文  
简体中文  
日本語  
한국어

**QUICK REFERENCE GUIDE**

Revision 1.0a



## Standardized Warning Statements

### Motherboards

#### About Standardized Warning Statements

The following statements are industry standard warnings, provided to warn the user of situations which can potentially cause a bodily injury. Should you have questions or experience difficulty, contact Supermicro's Technical Support Department for assistance. Only certified technicians should attempt to install or configure components.

Read this section in its entirety before installing or configuring components in the Supermicro chassis.



**WARNING:** This product can expose you to chemicals including lead, known to the State of California to cause cancer and birth defects or other reproductive harm. For more information, go to [www.P65Warnings.ca.gov](http://www.P65Warnings.ca.gov).

#### Battery Handling



##### Warning!

There is a danger of explosion if the battery is replaced incorrectly. Replace the battery only with the same or an equivalent type recommended by the manufacturer. Dispose of used batteries according to the manufacturer's instructions.

##### 警告

電池更換不當會有爆炸危險。請使用製造商建議之相同或功能相當的電池更換原有電池。請按照製造商的說明指示處理廢棄舊電池。

##### 警告

電池更換不當會有爆炸危險。請只使用同類電池或製造商推薦的功能相當的電池更換原有電池。請按製造商的說明處理廢舊電池。

##### 電池の取り扱い

電池交換が正しく行われなかった場合、破裂の危険性があります。交換する電池はメーカーが推奨する型、または同等のものを使用下さい。使用済電池は製造元の指示に従って処分して下さい。

##### 경고!

배터리가 올바르게 교체되지 않으면 폭발의 위험이 있습니다. 기존 배터리와 동일하거나 제조사에서 권장하는 동등한 종류의 배터리로만 교체해야 합니다. 제조사의 안내에 따라 사용된 배터리를 처리하여 주십시오.

هناك خطر من انفجار في حالة استبدال البطارية بطريقة غير صحيحة فعليك استبدال البطارية فقط بنفس النوع أو ما يعادلها كما أوصت به الشركة المصنعة تخلص من البطاريات المستعملة وفقا لتعليمات الشركة الصانعة

 **Note:** For complete product safety information, refer to [http://www.supermicro.com/about/policies/safety\\_information.cfm](http://www.supermicro.com/about/policies/safety_information.cfm).

## 限用物質含有情況標示聲明書

Declaration of the Presence Condition of the Restricted Substances Marking

設備名稱：主機板 / Motherboard Equipment name						
型號（型式）：C9Z590-CG, C9Z590-CGW Type designation (Type)						
單元 Unit	限用物質及其化學符號 Restricted substances and its chemical symbols					
	鉛Lead (Pb)	汞Mercury (Hg)	鎘Cadmium (Cd)	六價鉻 Hexavalent chromium (Cr <sup>+6</sup> )	多溴聯苯 Polybrominated biphenyls (PBB)	多溴二苯醚 Polybrominated diphenyl ethers (PBDE)
主機板 (Motherboard)	—	○	○	○	○	○
備考1. “超出0.1 wt %” 及 “超出0.01 wt %” 係指限用物質之百分比含量超出百分比含量基準值。 Note 1 : “Exceeding 0.1 wt %” and “exceeding 0.01 wt %” indicate that the percentage content of the restricted substance exceeds the reference percentage value of presence condition.						
備考2. “○” 係指該項限用物質之百分比含量未超出百分比含量基準值。 Note 2 : “○” indicates that the percentage content of the restricted substance does not exceed the percentage of reference value of presence.						
備考3. “—” 係指該項限用物質為排除項目。 Note 3 : The “—” indicates that the restricted substance corresponds to the exemption.						

## AMI BIOS POST Codes

### About AMI BIOS POST Codes

The table below lists some of AMI BIOS POST codes for C9Z490-PG/-PGW. For more information, refer to [https://www.supermicro.com/manuals/other/AMI\\_AptioV\\_BIOS\\_POST\\_Codes\\_for\\_SM\\_Motherboards.pdf](https://www.supermicro.com/manuals/other/AMI_AptioV_BIOS_POST_Codes_for_SM_Motherboards.pdf).

Code	Description
0x32	CPU post-memory initialization is started
0x55	No Memory detected or memory failed
0x63	CPU DXE initialization is started
0x69	North Bridge DXE initialization is started
0x70	South Bridge DXE initialization is started
0x92	PCI Bus initialization is started
0x99	Super IO Initialization
0x9A	USB initialization is started
0xA0	IDE initialization is started
0xA9	Boot into BIOS setup menu
0xAE	Legacy Boot event
0xB2	Legacy Option ROM Initialization
0xB4	USB hot plug
0xD6	No console output devices are found
0xD7	No console input devices are found
0xF2	Recovery process started
0xF9	Recovery capsule is not found

## M.2 Device Installation Instructions

### Installation with Pre-installed Standoffs

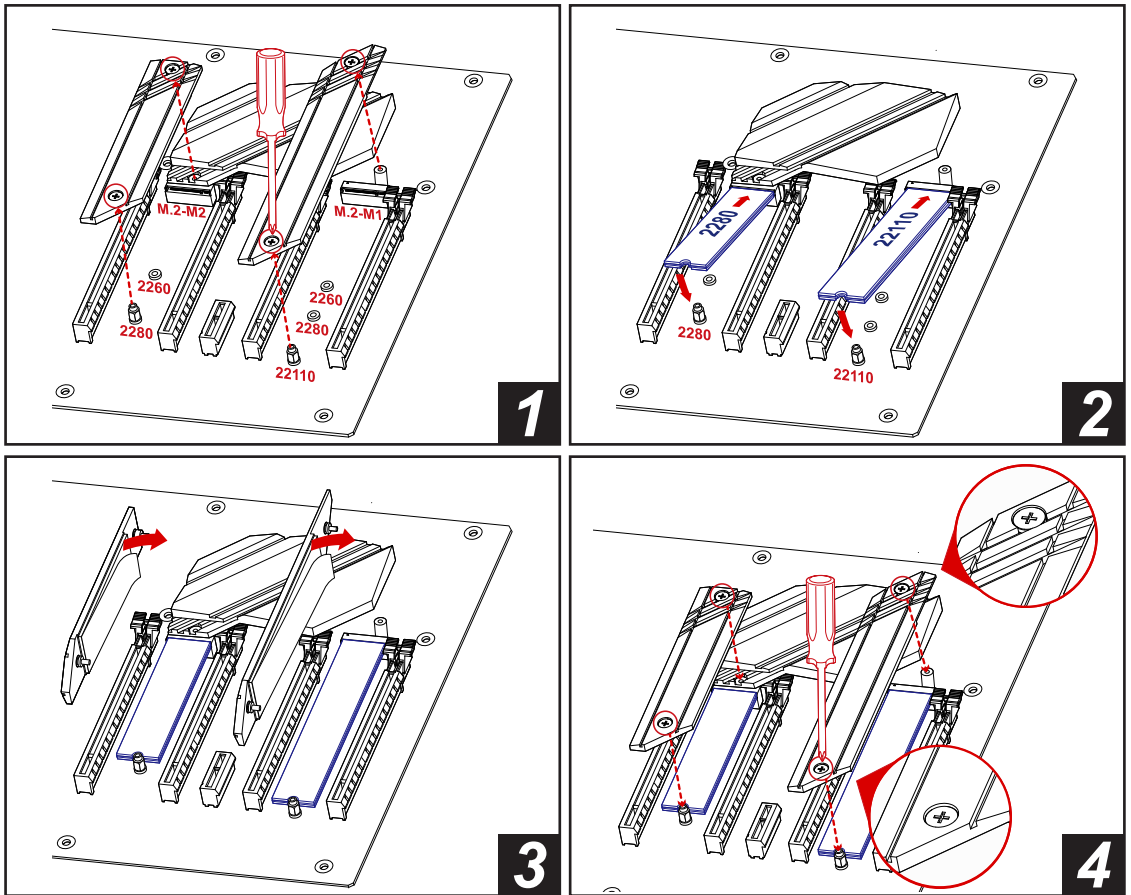

#### Notes:

1. The graphics shown above are examples of the M.2 installation. The motherboard you received may or may not look exactly the same.
2. **DO NOT** install the bounded M.2 heatsink (refer to images 3 and 4) if the M.2 device has a heatsink installed.
3. Please assemble the M.2 heatsink back to the motherboard once the M.2 device has been removed.
4. Beware of the direction when assembling the heatsink (refer to image 4).
5. Refer to the user's manual for more detailed descriptions.

## Installation without Pre-installed Standoffs

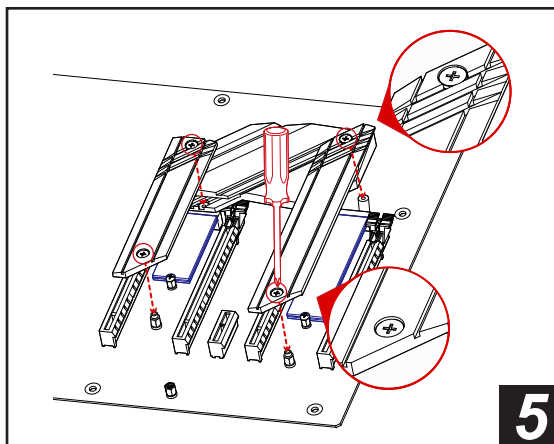
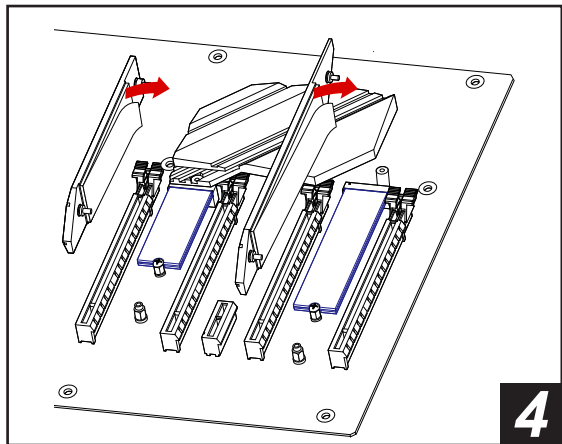
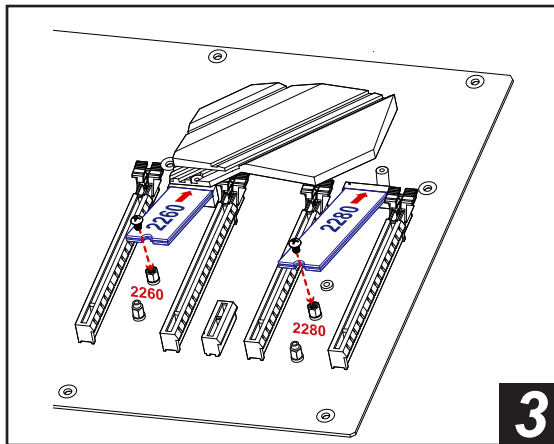
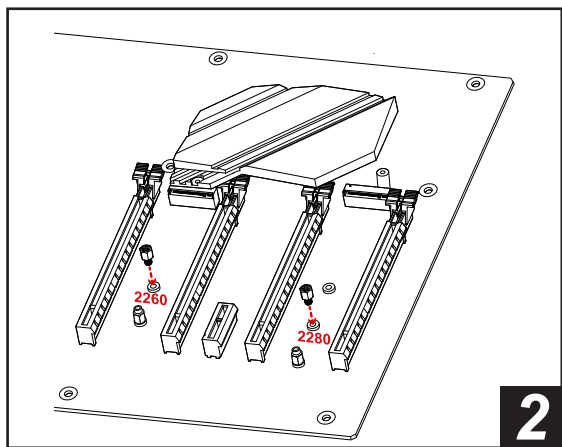
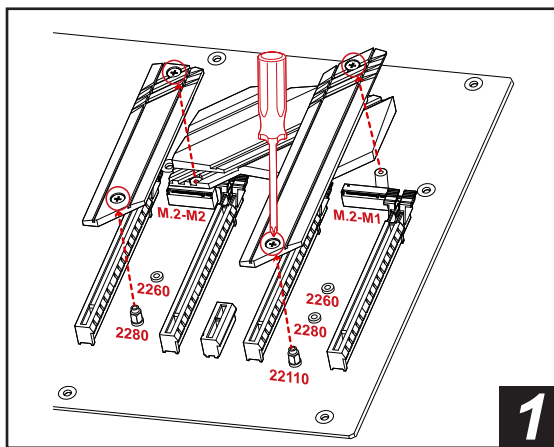

### Notes:

1. The graphics shown above are examples of the M.2 installation. The motherboard you received may or may not look exactly the same.
2. To install an M.2 22110 device, please refer to the instructions of Installation with Pre-installed Standoffs on the previous page.
3. **DO NOT** install the bounded M.2 heatsink (refer to images 4 and 5) if the M.2 device has a heatsink installed.
4. Please assemble the M.2 heatsink back to the motherboard once the M.2 device has been removed.
5. Beware of the direction when assembling the heatsink (refer to image 5).
6. Refer to the user's manual for more detailed descriptions.

### Audio Configuration



Audio Configuration				
	2 Channel	4.1 Channel	5.1 Channel	7.1 Channel
① Orange (Center/LFE Out)			Center/Subwoofer	Center/Subwoofer
② Black (Surround)		Rear Speaker Out	Rear Speaker Out	Rear Speaker Out
③ Light Blue (Line In/Side Speaker Out)	Line In	Line In	Line In	Side Speaker Out
④ Lime (Line Out/Front Speaker Out)	Line Out	Front Speaker Out	Front Speaker Out	Front Speaker Out
⑤ Pink (Mic In)	Mic In	Mic In	Mic In	Mic In

---

---

# Notes



## PACKAGE CONTENTS

- One Supermicro Motherboard
- Four SATA Cables
- One I/O Shield
- One S-Connector
- One Quick Reference Guide
- One Driver CD
- Two Antennas (C9Z590-CGW only)

## Jumpers and Connectors

Jumpers		
Jumper	Description	Default
CLEAR CMOS	Clear CMOS Switch	Push Button Switch
JD1	Speaker / Buzzer	Pins 1-4: External Speaker / Pins 3-4: Buzzer
JPME2	Intel Manufacturing Mode	Pins 1-2: Normal Pins 2-3: Manufacturing Mode
JWD1	Watch Dog Function Enable	Pins 1-2: RST / Pins 2-3: NMI
POWER BUTTON	Internal Power Button	Push Button Switch
RESET BUTTON	Onboard System Reset Button	Push Button Switch
SW1	Back Panel Clear CMOS Switch	Push Button Switch

Connectors	
Connector	Description
12V_PUMP_PWR1	12V 4-pin Power Connector for CPU Liquid Cooling Pump
AUDIO FP	Front Panel Audio Header
B1	Onboard Battery
COM1	COM1 Header
CPU_FAN1/CPU_FAN2	CPU Fan Headers
CPU SLOT5 PCI-E 4.0 x8 (IN x16)	PCIe 4.0 x16 Slot (PCIe 4.0 x8 Link) *CPU Slot5 PCIe 4.0 x8 (IN x16) slot shares PCIe x16 link with CPU Slot7 PCIe 4.0 x16 slot, therefore CPU Slot7 PCIe 4.0 x16 link will change to PCIe 4.0 x8 link when one graphics card is installed in CPU Slot5 PCIe 4.0 x8 (IN x16) slot.
CPU SLOT7 PCI-E 4.0 x16	PCIe 4.0 x16 Slot (PCIe 4.0 x16 Link) *Always plug in one graphics card in CPU Slot7 PCIe 4.0 x16 slot first to maximize performance.
DP/HDMI	Back Panel DisplayPort/High Definition Multimedia Interface
HD AUDIO	High Definition Audio Ports
I-SATA0~3	(Intel Z590) Serial ATA (SATA 3.0) Ports 0~3 (6Gb/sec)
JF1	Front Control Panel Header *Please align the printed indications on the S-Connector with the corresponding pins on JF1 when plugging in.
JL1	Chassis Intrusion Header
JLED1	Power LED Indicator Header
JPW1	24-pin ATX Main Power Connector (Required)
JPW2	+12V 8-pin CPU Power Connector (Required)
JRLED1	4-pin Connector for a White Light LED Board (Pre-installed) Inside the I/O cover
JSD1	SATA DOM (Disk-On-Module) Power Connector
JSTBY1	5V Standby Power Header
JTPM1	Trusted Platform Module (TPM)/Port 80 Header (Supports TPM 2.0 only)
LAN1/LAN2	RJ45 1GbE/10GbE LAN Ports
PCIE M.2-E1	WiFi 6 + BT 5.1 (Pre-installed, for C9Z590-CGW only)
PCIE M.2-M1/PCIE M.2-M2	PCIe 3.0x4 M.2 M-Key Sockets attached to the PCH. Support the type of 2260/2280/22110 Module NVMe SSD Storage Device and RAID 0, 1, and 5.
PCIE M.2-M3	PCIe 4.0 x4 M.2 M-Key Socket attached to the CPU. Supports the type of 2260/2280 Module NVMe SSD Storage Device and RAID 0, 1, and 5.
PCH SLOT1/4 PCI-E 3.0 x1	PCIe 3.0 x1 Slots (PCIe 3.0 x1 Link)
SP1	Internal Speaker/Buzzer
SYS_FAN1 ~ SYS_FAN3	System Fan Headers
USB0/1/2/3	Back Panel USB 2.0 Ports (Type A)
USB4/5	Front Panel Accessible USB 2.0 Header
USB6	Back Panel USB 3.2 Gen 2 Port (10Gb, Type A)
USB7	Back Panel USB 3.2 Gen 2x2 Port (20Gb, Type C)
USB8	Back Panel USB 3.2 Gen 2 Port (10Gb, Type A)
USB9	Back Panel USB 3.2 Gen 2x2 Port (20Gb, Type C)
USB10/11	Front Panel Accessible USB 3.2 Gen 1 Header (5Gb)
USB12	Front Panel Accessible USB 3.2 Gen 2x2 20-pin Connector (20Gb)

## CONTACT INFORMATION

- [www.supermicro.com](http://www.supermicro.com) (Email: [support@supermicro.com](mailto:support@supermicro.com))
- Manuals: <http://www.supermicro.com/support/manuals>
- Drivers & Utilities: <https://www.supermicro.com/wdl/driver/>
- Safety: [http://www.supermicro.com/about/policies/safety\\_information.cfm](http://www.supermicro.com/about/policies/safety_information.cfm)

## LED Indicators

LED Indicators		
LED	Description	Color/State
BOOT LED	Bootable Device Power-On Self-Test (POST) Status	Bootable Device POST: Orange ON Bootable Device POST Completion: OFF
CPU LED	CPU Power-On Self-Test (POST) Status	CPU POST: Yellow ON CPU POST Completion: OFF
DIMM LED	DIMM Power-On Self-Test (POST) Status	DIMM POST: Blue ON DIMM POST Completion: OFF
LED1	Onboard Power LED S3 (Suspend to RAM) LED	Power On: Green On S3: Green Blinking
LED17	WLAN Power-On Self-Test (POST) Status	WLAN POST: Green ON WLAN POST Completion: OFF
LED18	Bluetooth Device Power-On Self-Test (POST) Status	Bluetooth Device POST: Green ON Bluetooth Device POST Completion: OFF
LED2	PCIe M.2-M2 Socket LED	PCIe Device Detected: Green ON Activity: Green Blinking
LED3	PCIe M.2-M1 Socket LED	PCIe Device Detected: Green ON Activity: Green Blinking
LED4	BIOS POST Code LED	Digital Readout
LED4801	PCIe M.2-M3 Socket LED	PCIe Device Detected: Green ON Activity: Green Blinking
VGA LED	Onboard VGA Power-On Self-Test (POST) Status	Onboard VGA POST: Green ON Onboard VGA POST Completion: OFF

## CPU Installation

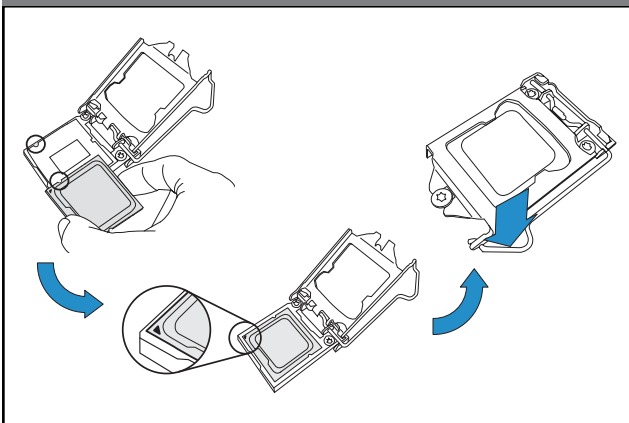

## Heatsink Installation

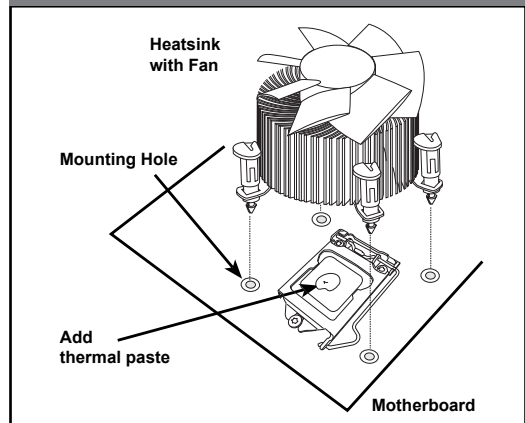

## Front Control Panel (JF1)

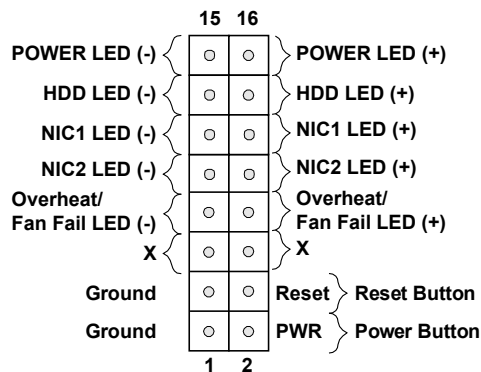

## NOTES

- Graphics shown in this quick reference guide are for illustration only. Your components may or may not look exactly the same as drawings shown in this guide.
- Refer to Chapter 2 of the User Manual for detailed information on jumpers, connectors, LED indicators, memory support and CPU/motherboard installation instructions.

## CPU & Memory Support

The C9Z590-CG/-CGW supports a single 11th Generation Intel® Core™ i9/i7/i5 series processor (LGA1200 socket), up to 128GB of Unbuffered non-ECC UDIMM with speeds of up to 3200MHz (2DPC, by CPU) in four 288-pin memory slots. Populating these DIMM slots with a pair of memory modules of the same type and size will result in interleaved memory, which will improve memory performance.

**Notes:** 1) For memory optimization, use only DIMM modules that have been validated by Supermicro. For the latest memory updates, please refer to our website at <http://www.supermicro.com/products/motherboard>.

- 2) Always connect the power cord last, and always remove it before adding, removing or changing any hardware components.
- 3) Overheating can seriously damage CPU and motherboard. Always make sure cooling fans function properly to protect CPU from overheating.
- 4) This motherboard supports only an 11th Gen Intel Core series processor. The system will not boot up if using the 10th Gen Intel Core series processor.

### DIMM Memory Installation

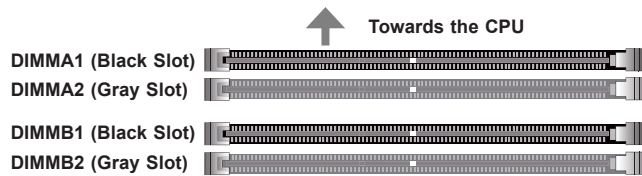

### Memory Population Guidelines

When installing memory modules, the DIMM slots should be populated in the following order: DIMMA2, DIMMB2, then DIMMA1, DIMMB1.

- Always use DDR4 DIMM modules of the same size, type, and speed.
- Mixed DIMM speeds can be installed. However, all DIMMs will run at the speed of the slowest DIMM.

#### Recommended Population (Balanced)

DIMMA1	DIMMB1	DIMMA2	DIMMB2	Total System Memory
		2GB DIMM	2GB DIMM	4GB
2GB DIMM	2GB DIMM	2GB DIMM	2GB DIMM	8GB
		4GB DIMM	4GB DIMM	8GB
4GB DIMM	4GB DIMM	4GB DIMM	4GB DIMM	16GB
		8GB DIMM	8GB DIMM	16GB
8GB DIMM	8GB DIMM	8GB DIMM	8GB DIMM	32GB
		16GB DIMM	16GB DIMM	32GB
16GB DIMM	16GB DIMM	16GB DIMM	16GB DIMM	64GB
		32GB DIMM	32GB DIMM	64GB
32GB DIMM	32GB DIMM	32GB DIMM	32GB DIMM	128GB

## Back Panel I/O Connectors

1. DisplayPort 1.4a	7. Ethernet RJ45 10GbE Port 2	13. Surround Out
2. HDMI Port 2.0b	8. USB8: USB 3.2 Gen 2 (10Gb, Type A)	14. S/PDIF Out
3. USB0/1/2/3: USB 2.0 (Type A)	9. USB9: USB 3.2 Gen 2x2 (20Gb, Type C)	15. Line In
4. Ethernet RJ45 1GbE Port 1	10. SW1: CLEAR CMOS	16. Line Out
5. USB6: USB 3.2 Gen 2 (10Gb, Type A)	11. WiFi 6+BT 5.1 (C9Z590-CGW only)	17. Mic In
6. USB7: USB 3.2 Gen 2x2 (20Gb, Type C)	12. Center/LFE Out	

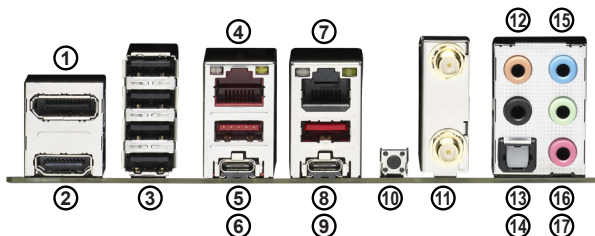

#### 主機板元件配置圖

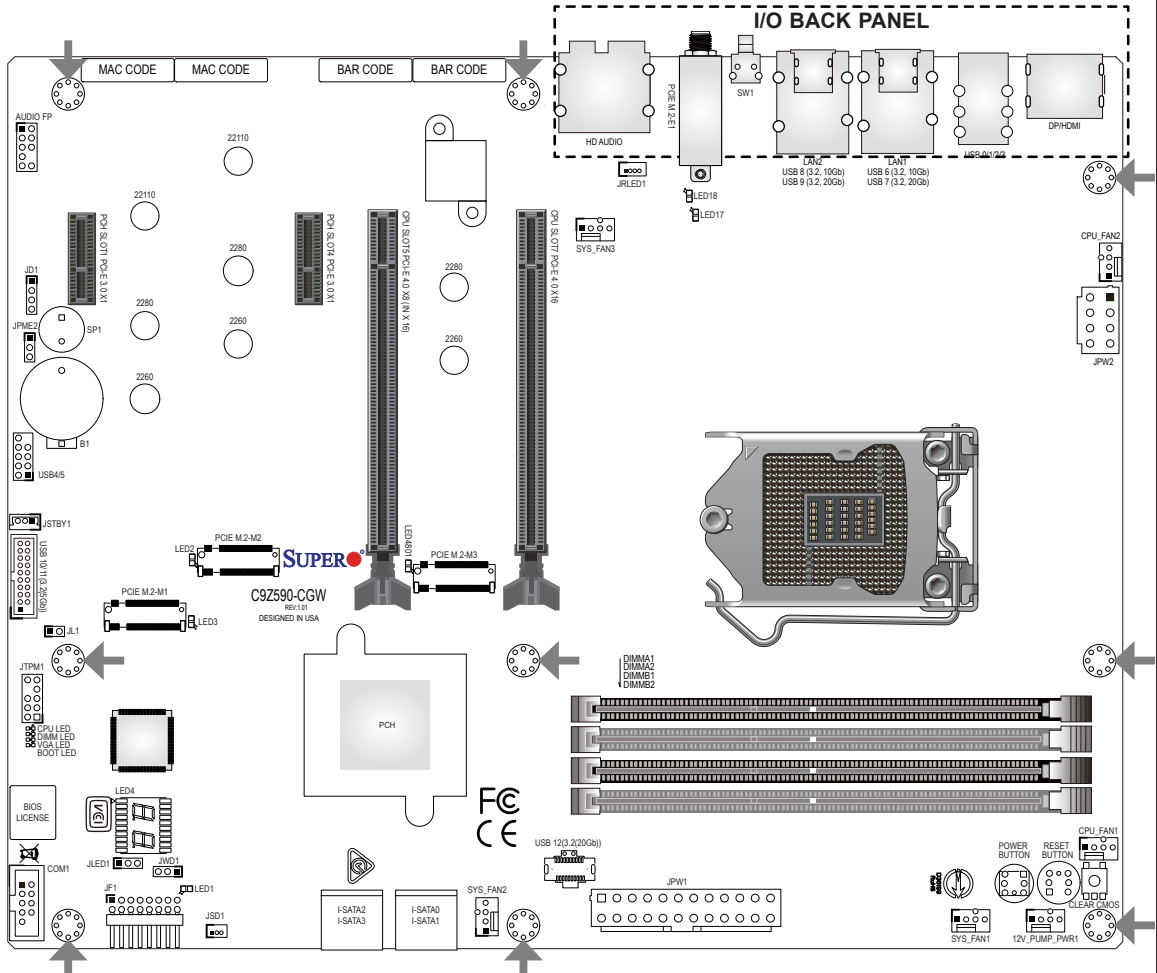

➔ = 裝機孔

## 單一主機板包裝盒內容清單

- Supermicro主機板 x1
- SATA訊號線 x4
- 後檔板 x1
- S-轉接器 x1
- 快速參考指南 x1
- 驅動程式光碟片 x1
- 天線 x2 (僅 C9Z590-CGW 提供)

## 跳線器/連接埠

跳線器 ( Jumper )		
跳線器	說明	預設值
CLEAR CMOS	CMOS ( 可讀寫隨機存取記憶體晶片 ) 組態資料清除開關	按鍵式開關
JD1	喇叭 / 蜂鳴器	針腳 1-4 : 外接喇叭 / 針腳 3-4 : 蜂鳴器
JPME2	Intel製造模式	針腳 1-2 : 正常 / 針腳 2-3 : 製造模式
JWD1	啟動系統監控 ( Watch Dog ) 功能	針腳 1-2 : 重設 / 針腳 2-3 : NMI
POWER BUTTON	內部電源開關	按鍵式開關
RESET BUTTON	系統重設開關	按鍵式開關
SW1	背板CMOS ( 可讀寫隨機存取記憶體晶片 ) 組態資料清除開關	按鍵式開關

連接埠 ( Connector )	
連接埠	說明
12V_PUMP_PWR1	12V水冷幫浦電源插座
AUDIO FP	前面板音效接頭
B1	內建電池
COM1	COM1序列連接埠
CPU_FAN1/CPU_FAN2	CPU ( 中央處理器 ) 風扇接頭
CPU SLOT5 PCI-E 4.0 x8 ( IN x16 )	PCIe 4.0 x16插槽 · 支援PCIe 4.0 x8運作效能規格 *CPU Slot5 PCIe 4.0 x8 ( IN x16 ) 插槽與CPU Slot7 PCIe 4.0 x16插槽共享頻寬 · 所以當CPU Slot5 PCIe 4.0 x8 ( IN x16 ) 插槽安裝顯示卡時 · CPU Slot7 PCIe 4.0 x16插槽最高以 x8頻寬運作 ·
CPU SLOT7 PCI-E 4.0 x16	PCIe 4.0 x16插槽 · 支援PCIe 4.0 x16運作效能規格 *為發揮顯示卡最大效能 · 如只安裝一張顯示卡時務必優先安裝至CPU Slot7 PCIe 4.0 x16插槽 ·
DP/HDMI	背板DisplayPort顯示連接埠/高畫質多媒體介面 ( HDMI ) 連接埠
HD AUDIO	背板5個音源接頭 ( 中央及重低音輸出、後喇叭輸出、音源輸入、音源輸出、麥克風 ) 和1個S/PDIF光纖輸出插座
I-SATA0~3	( Intel Z590 ) 序列ATA介面 ( SATA 3.0 ) 連接埠 0~3 ( 6Gb/秒 )
JF1	前控制面板接頭 *請參照S-轉接器上面的印刷標示連接對應的前控制面板針腳 ·
JL1	機殼防盜裝置接頭
JLED1	LED指示燈電源接頭
JPW1	24針腳ATX主電源連接埠 ( 必備 )
JPW2	+12伏特8針腳CPU電源連接埠 ( 必備 )
JRLED1	4-pin 接頭連接I/O上蓋內部的白光LED導光板 ( 已安裝 )
JSD1	SATA DOM ( 磁碟模組 ) 電源連接埠
JSTBY1	5V待機電源接頭
JTPM1	TPM信任平台模組/Port 80 插座 ( 僅支援TPM 2.0 )
LAN1/LAN2	RJ45 1GbE/10GbE 網路連接埠
PCIE M.2-E1	WiFi 6 + BT 5.1 ( C9Z590-PGW 出貨預連接一張無線網卡 )
PCIE M.2-M1/PCIE M.2-M2	PCIe 3.0 x4 M.2介面連接埠 ( 連接PCH ) · 適用2260/2280/22110高速傳輸NVMe介面的固態硬碟儲存裝置 · 並支援RAID1、0和5 ( 註 : PCIe為電腦匯流的一種規格、M.2為固態硬碟的一種傳輸介面 · 而NVMe為非揮發性記憶體儲存裝置的一種標準 · )
PCIE M.2-M3	PCIe 4.0 x4 M.2介面連接埠 ( 連接CPU ) · 適用2260/2280高速傳輸NVMe介面的固態硬碟儲存裝置 · 並支援RAID1、0和5
PCH SLOT1/4 PCI-E 3.0 x1	PCIe 3.0 x1插槽 · 支援PCIe 3.0 x1運作效能規格
SP1	內部喇叭/蜂鳴器
SYS_FAN1 ~ SYS_FAN3	系統風扇接頭
USB0/1/2/3	背板USB 2.0 規格接頭 ( Type A )
USB4/5	前面板USB 2.0 規格接頭
USB6	背板USB 3.2 Gen 2規格連接埠 ( 10Gb · Type A )
USB7	背板USB3.2 Gen 2x2 規格連接埠 ( 20Gb · Type C )
USB8	背板USB 3.2 Gen 2 規格連接埠 ( 10Gb · Type A )
USB9	背板USB 3.2 Gen 2x2 規格連接埠 ( 20Gb · Type C )
USB10/11	前面板USB 3.2 Gen 1規格接頭 ( 5Gb )
USB12	USB 3.2 Gen 2x2規格連接埠 · 適用於連接機殼前面板Type C連接埠 ( 20Gb )

## 線上技術支援及下載

- 聯絡我們 ( 技術支援信箱 ) : [www.supermicro.com](http://www.supermicro.com) ( Email: [support@supermicro.com](mailto:support@supermicro.com) )
- 產品手冊文件 : <http://www.supermicro.com/support/manuals>
- 驅動程式及工具程式 : <https://www.supermicro.com/wdl/driver/>
- 產品安全性須知 : [http://www.supermicro.com/about/policies/safety\\_information.cfm](http://www.supermicro.com/about/policies/safety_information.cfm)

## LED指示燈

LED 指示燈		
LED	說明	燈號顏色/狀態
BOOT LED	顯示硬碟開機時POST (開機自我檢測) 狀態	正在執行硬碟POST程序: 橘燈 完成硬碟POST程序: 燈滅
CPU LED	顯示CPU POST (開機自我檢測) 狀態	正在執行CPU POST程序: 黃燈 完成CPU POST程序: 燈滅
DIMM LED	顯示記憶體POST (開機自我檢測) 狀態	正在執行記憶體POST程序: 藍燈 完成記憶體POST程序: 燈滅
LED1	開啟/S3模式 (待機) 指示燈	開機: 綠燈 待機S3模式: 綠燈閃爍
LED17	無線網路 POST (開機自我檢測) 狀態	正在執行WiFi POST程序: 綠燈 完成WiFi POST程序: 燈滅
LED18	藍芽POST (開機自我檢測) 狀態	正在執行藍芽POST程序: 綠燈 完成藍芽POST程序: 燈滅
LED2	PCIe M.2-M2指示燈	偵測到裝置: 綠燈恆亮 裝置運作中: 綠燈閃爍
LED3	PCIe M.2-M1指示燈	偵測到裝置: 綠燈恆亮 裝置運作中: 綠燈閃爍
LED4	BIOS POST代碼指示燈	數位式讀值
LED4801	PCIe M.2-M3指示燈	偵測到裝置: 綠燈恆亮 裝置運作中: 綠燈閃爍
VGA LED	顯示VGA顯示卡開機時POST (開機自我檢測) 狀態	正在執行VGA顯示卡POST程序: 綠燈 完成VGA顯示卡POST程序: 燈滅

## 中央處理器安裝方式

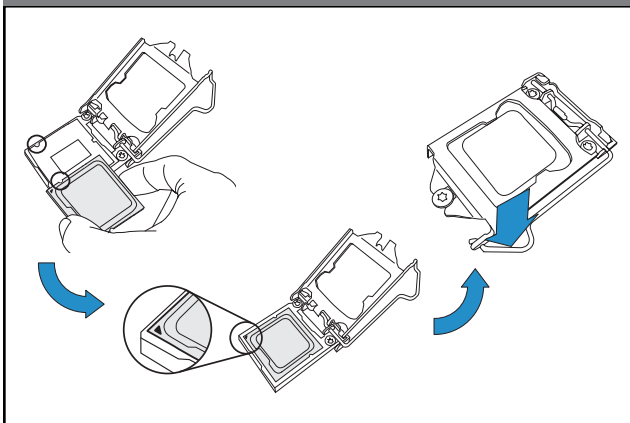

## 散熱器安裝方式

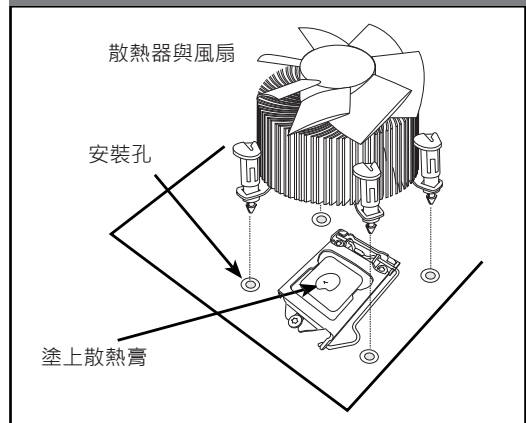

## 前控制面板配置 ( JF1 )

電源 LED (-)	15	16	電源 LED (+)	15	16	POWER LED (-)	15	16	POWER LED (+)
硬碟 LED (-)			硬碟 LED (+)			HDD LED (-)			HDD LED (+)
網卡1 LED (-)			網卡1 LED (+)			NIC1 LED (-)			NIC1 LED (+)
網卡2 LED (-)			網卡2 LED (+)			NIC2 LED (-)			NIC2 LED (+)
過熱/ 風扇故障 LED (-)			過熱/ 風扇故障 LED (+)			Overheat/ Fan Fail LED (-)			Overheat/ Fan Fail LED (+)
X			X			X			X
接地			重設			Ground			Reset
接地			電源			Ground			PWR
	1	2		1	2		1	2	

## 備註

- 快速參考指南中的圖例僅供安裝及操作說明使用，可能與實際產品外觀不同。
- 欲知更多跳線器/連接埠/指示燈/記憶體/主機板/中央處理器的安裝相關資訊，請參閱《SUPERMICRO C9Z590-CG/-CGW使用手冊》第二章。

## 中央處理器和記憶體支援

本主機板 C9Z590-CG/-CGW 支援單顆第十一代Intel® Core™ i9/i7/i5 系列處理器 (LGA1200插槽)。記憶體支援四組Unbuffered DIMM non-ECC DDR4，容量最高128GB，速度最高達3200MHz (2DPC，根據使用的處理器規格) 288支針腳的記憶體插槽。欲取得雙通道效能，請安裝成對相同型號與速度之記憶體。

- 註：1) 請安裝使用本公司所認可的記憶體模組以達記憶體模組最佳化。更多的記憶體模組相關訊息，請參閱本公司網頁 (<http://www.supermicro.com/products/motherboard>)。
- 2) 增加、移除和更換任何硬體元件前，請務必先拔掉電源線。待確實完成所有程序後，再重新連接電源線。
- 3) 請確保冷卻風扇工作正常，以避免系統過熱損壞處理器和主機板。
- 4) 本主機板僅支援第11代Intel Core系列處理器。如果在此主機板上安裝第10代Intel Core系列處理器，系統將無法開機。

### DIMM (記憶體模組) 安裝方式

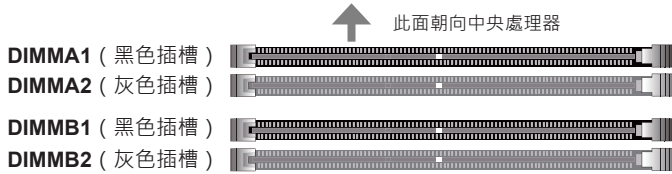

請依照以下說明及表格安裝記憶體模組：

- 請遵循下列插槽編號順序依序安裝：DIMMA2 (通道A、插槽2)、DIMMB2 (通道B、插槽2)、DIMMA1 (通道A、插槽1)、DIMMB1 (通道B、插槽1)。
- 請使用相同型號 (DDR4 DIMM) 與速度之記憶體。若混合使用不同速度之記憶體，系統將依較低的記憶體速度執行。

建議插槽使用方式				
DIMMA1	DIMMB1	DIMMA2	DIMMB2	系統記憶體總容量
		2GB DIMM	2GB DIMM	4GB
2GB DIMM	2GB DIMM	2GB DIMM	2GB DIMM	8GB
		4GB DIMM	4GB DIMM	8GB
4GB DIMM	4GB DIMM	4GB DIMM	4GB DIMM	16GB
		8GB DIMM	8GB DIMM	16GB
8GB DIMM	8GB DIMM	8GB DIMM	8GB DIMM	32GB
		16GB DIMM	16GB DIMM	32GB
16GB DIMM	16GB DIMM	16GB DIMM	16GB DIMM	64GB
		32GB DIMM	32GB DIMM	64GB
32GB DIMM	32GB DIMM	32GB DIMM	32GB DIMM	128GB

## 背板輸出/輸入連接埠

1. DisplayPort 1.4a 顯示連接埠	7. RJ45 10GbE網路線連接埠 2	13. 環繞聲道輸出
2. 高畫質多媒體介面HDMI 2.0b 連接埠	8. USB8: USB 3.2 Gen 2 (10Gb, Type A) 連接埠	14. S/PDIF輸出
3. USB0/1/2/3: USB 2.0 (Type A) 連接埠	9. USB9: USB 3.2 Gen 2x2 (20Gb, Type C) 連接埠	15. 音效輸入
4. RJ45 1GbE網路線連接埠 1	10. SW1: CMOS組態資料清除	16. 音效輸出
5. USB6: USB 3.2 (10Gb, Type A) 連接埠	11. Wi-Fi 6+BT 5.1 (僅 C9Z590-CGW)	17. 麥克風插孔
6. USB7: USB 3.2 Gen 2x2 (20Gb, Type C) 連接埠	12. 中央/低音聲道輸出	

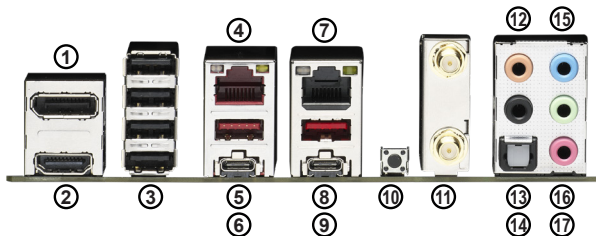

#### 主板元件功能布局图

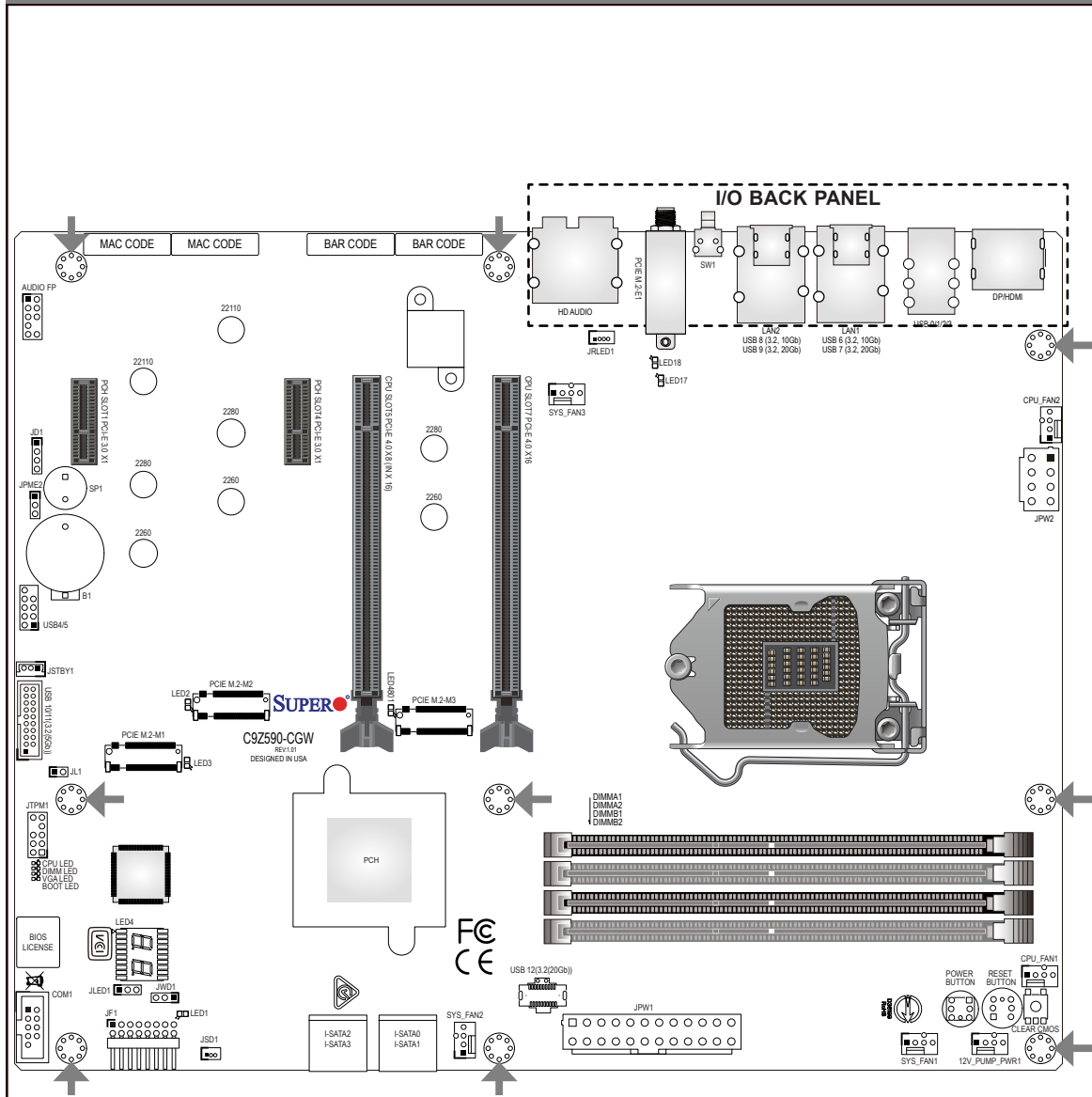

➔ = 螺丝孔

## 单一主板包装盒内容清单

- Supermicro主板 x1
- SATA数据线 x4
- 后挡板 x1
- S-转接器 x1
- 快速参考指南 x1
- 驱动程序光盘 x1
- 天线 x2 (仅 C9Z590-CGW 提供)

## 跳帽/接口

跳帽 (Jumper)		
跳帽	说明	默认值
CLEAR CMOS	清除CMOS开关	按键式开关
JD1	喇叭/蜂鸣器	针脚 1~4: 外接喇叭 / 针脚 3~4: 蜂鸣器
JPME2	Intel制造模式	针脚 1-2 : 正常 / 针脚 2-3 : 制造模式
JWD1	启动系统监控 (Watch Dog) 功能	针脚1-2 : 重设 / 针脚 2-3 : NMI
POWER BUTTON	内部电源开关	按键式开关
RESET BUTTON	系统重设开关	按键式开关
SW1	背板CMOS资料清除开关	按键式开关

接口 (Connector)	
接口	说明
12V_PUMP_PWR1	用于CPU液体冷却泵的12V 4针脚电源接口
AUDIO FP	高清音频接口 (背板)
B1	纽扣型电池
COM1	COM1串口
CPU_FAN1/CPU_FAN2	CPU风扇接口
CPU SLOT5 PCI-E 4.0 x8 (IN x16)	PCIe 4.0 x16插槽 (PCIe 4.0 x8总线规格) *CPU Slot5 PCIe 4.0 x8 (IN x16) 插槽与CPU Slot7 PCIe 4.0 x16插槽共享带宽, 所以当CPU Slot5 PCIe 4.0 x8 (IN x16) 插槽安装显卡时, CPU Slot7 PCIe 4.0 x16插槽最高以 x8带宽运行。
CPU SLOT7 PCI-E 4.0 x16	PCIe 4.0 x16插槽 (PCIe 4.0 x16总线规格) *为发挥显卡最大效能, 如只安装一张显卡时务必优先安装至CPU Slot7 PCIe 4.0 x16插槽。
DP/HDMI	背板DisplayPort显示接口/高清多媒体接口 (HDMI) 接口
HD AUDIO	背板5个音源接头 (中央及重低音输出、后喇叭输出、音源输入、音源输出、麦克风) 和1个S/PDIF光纤输出接口
I-SATA0~3	(Intel Z590) 串行ATA (SATA 3.0) 接口 0~3 (6Gb/秒)
JF1	前控制面板接口 *请参照S-转接器上面的印刷标示连接对应的前控制面板针脚。
JL1	机箱入侵检测接口
JLED1	LED指示灯电源接口
JPW1	24针脚ATX主电源接口 (必备)
JPW2	+12V 8针脚CPU电源接口 (必备)
JRLED1	4-pin 接头, 连接I/O上盖内部的白光LED导光板 (已安装)
JSD1	SATA DOM (磁盘模组) 电源接口
JSTBY1	待机电源接口
JTPM1	TPM信任平台模组接口/Port 80 接口 (仅支持TPM 2.0)
LAN1/LAN2	RJ45 1GbE/10GbE 网络接口
PCIE M.2-E1	WiFi 6 + BT 5.1 (C9Z590-CGW出货预连接一张无线网卡)
PCIE M.2-M1/PCIE M.2-M2	PCIe 3.0 x4 M.2接口 (连接PCH), 适用2260/2280/22110高速传输NVMe接口的固态硬盘储存设备, 并支持RAID1、0和5 (注: PCIe为电脑总线的一种规格、M.2为固态硬盘的一种传输接口, 而NVMe为非挥发性记忆体储存设备的一种标准。)
PCIE M.2-M3	PCIe 4.0 x4 M.2接口 (连接CPU), 适用2260/2280高速传输NVMe接口的固态硬盘储存设备, 并支持RAID1、0和5
PCH SLOT1/4 PCI-E 3.0 x1	PCIe 3.0 x1插槽 (PCIe 3.0 x1总线规格)
SP1	内部喇叭/蜂鸣器
SYS_FAN1 ~ SYS_FAN3	系统风扇接口
USB0/1/2/3	背板USB 2.0 接口 (Type A)
USB4/5	前置USB 2.0 接口
USB6	背板 3.2 Gen 2 接口 (10Gb, Type A)
USB7	背板 3.2 Gen 2x2 接口 (20Gb, Type C)
USB8	背板 3.2 Gen 2 接口 (10Gb, Type A)
USB9	背板 3.2 Gen 2x2 接口 (20Gb, Type C)
USB10/11	前置USB 3.2 Gen 1 接口 (5Gb)
USB12	前置USB 3.2 Gen 2x2 20针脚接口 (20Gb)

## 在线技术支持及下载

- 联络我们（技术支持信箱）：[www.supermicro.com](http://www.supermicro.com)（Email: [support@supermicro.com](mailto:support@supermicro.com)）
- 产品手册文件：<http://www.supermicro.com/support/manuals>
- 驱动程序及工具软件：<https://www.supermicro.com/wdl/driver/>
- 产品安全性须知：[http://www.supermicro.com/about/policies/safety\\_information.cfm](http://www.supermicro.com/about/policies/safety_information.cfm)

## LED指示灯

LED 指示灯		
LED	说明	灯号颜色/状态
BOOT LED	显示启动设备POST (开机自检) 状态	正在执行启动设备POST程序: 橘灯 完成启动设备POST程序: 灯灭
CPU LED	显示CPU POST (开机自检) 状态	正在执行CPU POST程序: 黄灯 完成CPU POST程序: 灯灭
DIMM LED	显示内存POST (开机自检) 状态	正在执行内存POST程序: 蓝灯 完成内存POST程序: 灯灭
LED1	开启/S3模式 (待机) 指示灯	开机: 绿灯 待机S3模式: 绿灯闪烁
LED17	WiFi无线网络 POST (开机自检) 状态	正在执行WiFi POST程序: 绿灯 完成WiFi POST程序: 灯灭
LED18	蓝芽 POST (开机自检) 状态	正在执行蓝芽POST程序: 绿灯 完成蓝芽POST程序: 灯灭
LED2	PCIe M.2-M2指示灯	侦测到设备: 绿灯恒亮 设备运行中: 绿灯闪烁
LED3	PCIe M.2-M1指示灯	侦测到设备: 绿灯恒亮 设备运行中: 绿灯闪烁
LED4	BIOS POST代码指示灯	数位式读值
LED4801	PCIe M.2-M3指示灯	侦测到设备: 绿灯恒亮 设备运行中: 绿灯闪烁
VGA LED	显示VGA显卡开机时POST (开机自检) 状态	正在执行VGA显卡POST程序: 绿橙 完成VGA显卡POST程序: 灯灭

## 中央处理器安装方式

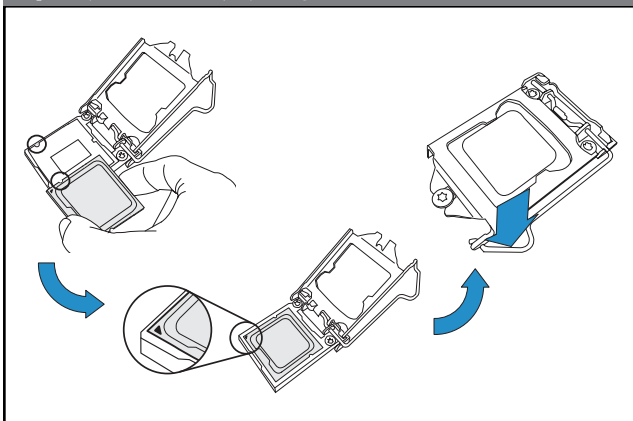

## 散热器安装方式

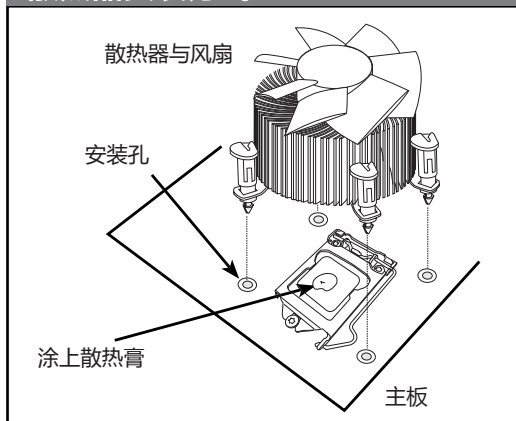

## 前控制面板配置 (JF1)

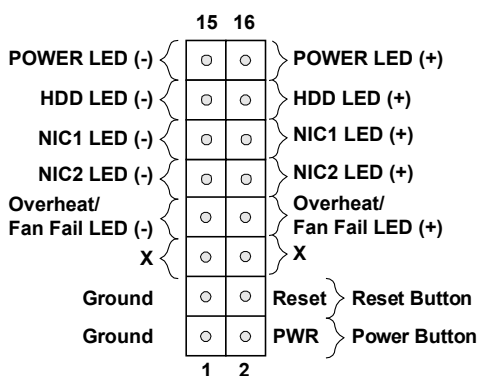
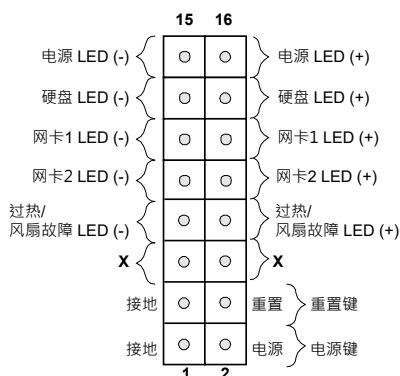

## 备注

- 快速参考指南中的图例仅供安装及操作说明使用，可能与实际产品外观不同。
- 欲知更多跳帽/接口/指示灯/内存/主板/中央处理器的安装相关信息，请参阅《SUPERMICRO C9Z590-CG/-CGW使用手册》第二章。

## 中央处理器和内存支持

本主板 C9Z590-CG/-CGW 支持单颗第十一代Intel® Core™ i9/i7/i5 系列处理器 (LGA1200接口)。内存支持四组 Unbuffered DIMM non-ECC DDR4, 容量最高可达128GB, 速度最高达3200MHz (2DPC, 根据使用的处理器规格) 288支针脚的内存插槽。欲取得双通道效能, 请安装成对相同型号与速度之内存。

- 註: 1) 请安装使用本公司所认可的内存模块以达内存模块优化。更多的内存模块相关资讯, 请参阅本公司网页 (<http://www.supermicro.com/products/motherboard>)。
- 2) 增加、移除和更换任何硬件组件前, 请务必先拔掉电源线。待确认完成所有程序后, 再重新连接电源线。
- 3) 请确保冷却风扇工作正常, 以避免系统过热损坏处理器和主板。
- 4) 本主板仅支持第11代Intel Core系列处理器。如果在此主板上安装第10代Intel Core系列处理器, 系统将无法开机。

## DIMM (内存模块) 安装方式

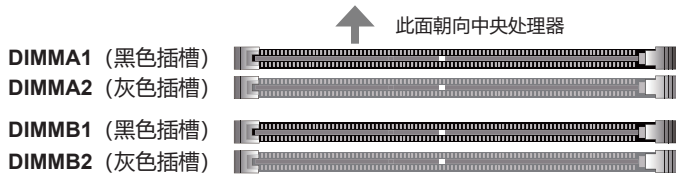

### 请依照以下说明及表格安装内存模块:

- 请遵循下列插槽编号顺序依序安装: DIMMA2 (通道A、插槽2)、DIMMB2 (通道B、插槽2)、DIMMA1 (通道A、插槽1)、DIMMB1 (通道B、插槽1)。
- 请使用相同型号 (DDR4 DIMM) 与速度之内存。若混合使用不同速度之内存, 系统将依较低的内存速度执行。

建议插槽使用方式

DIMMA1	DIMMB1	DIMMA2	DIMMB2	系统内存总容量
		2GB DIMM	2GB DIMM	4GB
2GB DIMM	2GB DIMM	2GB DIMM	2GB DIMM	8GB
		4GB DIMM	4GB DIMM	8GB
4GB DIMM	4GB DIMM	4GB DIMM	4GB DIMM	16GB
		8GB DIMM	8GB DIMM	16GB
8GB DIMM	8GB DIMM	8GB DIMM	8GB DIMM	32GB
		16GB DIMM	16GB DIMM	32GB
16GB DIMM	16GB DIMM	16GB DIMM	16GB DIMM	64GB
		32GB DIMM	32GB DIMM	64GB
32GB DIMM	32GB DIMM	32GB DIMM	32GB DIMM	128GB

## 背板输出/输入端口

1. DisplayPort 1.4a 接口	7. RJ45 10GbE LAN2接口	13. 环绕声道输出
2. HDMI 2.0b 接口	8. USB8: USB 3.2 Gen 2 (10Gb, Type A)	14. S/PDIF输出
3. USB0/1/2/3: USB 2.0 (Type A)	9. USB9: USB 3.2 Gen 2x2 (20Gb, Type C)	15. 音效输入
4. RJ45 1GbE LAN1接口	10. SW1: 背板CMOS资料清除开关	16. 音效输出
5. USB6: USB 3.2 (10Gb, Type A)	11. WiFi 6+BT 5.1 (仅限 C9Z590-CGW)	17. 麦克风插孔
6. USB7: USB 3.2 Gen 2x2 (20Gb, Type C)	12. 中央/低音声道输出	

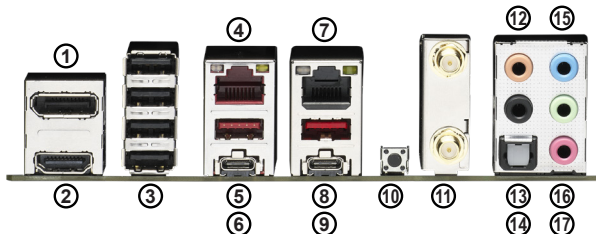



## パッケージ内容

- Supermicro マザーボード 1枚
- SATA ケーブル 4本
- I/O シールド 1個
- S-コネクタ 1個
- クイック参照ガイド 1個
- ドライバーCD 1枚
- アンテナ 2本 (C9Z590-CGWのみ)

## ジャンパーおよびコネクタ

ジャンパー		
ジャンパー	説明	デフォルト
CLEAR CMOS	CMOSクリアスイッチ	ボタンスイッチ
JD1	スピーカー/ブザー	ピン 1~4 : 外部スピーカー / ピン 3~4 : ブザー
JPME2	Intel マニユファクチャーモード	ピン 1~2 : ノーマル ピン 2~3 : マニユファクチャーモード
JWD1	ウォッチドッグ機能の有効化	ピン 1~2 : RST / ピン 2~3 : NMI
POWER BUTTON	オンボード電源ボタン	ボタンスイッチ
RESET BUTTON	オンボードシステムリセットボタン	ボタンスイッチ
SW1	バックパネル CMOSクリアスイッチ	ボタンスイッチ

コネクタ	
コネクタ	説明
12V_PUMP_PWR1	12V 4ピン CPU水冷ポンプ用電源コネクタ
AUDIO FP	フロントパネル オーディオヘッダー
B1	オンボードバッテリー
COM1	COM1ヘッダー
CPU_FAN1/CPU_FAN2	CPUファンヘッダー
CPU SLOT5 PCI-E 4.0 x8 (IN x16)	PCIe 4.0 x16 スロット (PCIe 4.0 x8 リンク) *CPU スロット5 PCIe 4.0 x8 (IN x16) スロットは、PCIe x16リンクをCPU スロット7 PCIe 4.0 x16 スロットと共有しています。このため、CPU スロット5 PCIe 4.0 x8 (IN x16) スロットに1枚のグラフィックカードが取り付けられると、CPU スロット7 PCIe 4.0 x16 リンクは PCIe 4.0 x8 リンクに変更されます。
CPU SLOT7 PCI-E 4.0 x16	PCIe 4.0 x16 スロット (PCIe 4.0 x16 リンク) *パフォーマンスを最大限に高めるため、常に最初にCPU スロット7 PCIe 4.0 x16 スロットに1枚のグラフィックカードを挿入するようにしてください。
DP/HDMI	バックパネル DisplayPort/Hাইデフィニション マルチメディアインターフェース
HD AUDIO	ハイレジニション オーディオポート
I-SATA0~3	(Intel Z590) シリアル ATA (SATA 3.0) ポート 0~3 (6Gb/秒)
JF1	フロント コントロールパネル ヘッダー *プラグを差し込む際には、Sコネクタの印刷された表示をJF1の対応するピンに合わせてください。
JL1	シャーン侵入ヘッダー
JLED1	電源LEDインジケーターヘッダー
JPW1	24ピン ATX 主電源コネクタ (必須)
JPW2	+12V 8ピン CPU 電源コネクタ (必須)
JRLED1	白色光LED基板用4ピンコネクタ (プリインストール済み) I/Oカバー内
JSD1	SATA DOM (Disk-On-Module) 電源コネクタ
JSTBY1	5V スタンバイ電源ヘッダー
JTPM1	Trusted Platform Module (TPM)ポート 80 ヘッダー (TPM 2.0 のみをサポート)
LAN1/LAN2	RJ45 1GbE/10GbE LAN ポート
PCIE M.2-E1	WiFi 6 + BT 5.1 (プリインストール済み、C9Z590-CGWのみ)
PCIE M.2-M1/PCIE M.2-M2	PCHに取り付けられたPCIe 3.0x4 M.2 Mキーソケット。2260/2280/22110モジュール NVMe SSD ストレージデバイスおよびRAID0、1、5のタイプをサポートします。
PCIE M.2-M3	CPUに取り付けられたPCIe 4.0x4 M.2 Mキーソケット。2260/2280モジュール NVMe SSD ストレージデバイスおよびRAID0、1、5のタイプをサポートします。
PCH SLOT1/4 PCI-E 3.0 x1	PCIe 3.0 x1 スロット (PCIe 3.0 x1 リンク)
SP1	内部スピーカー/ブザー
SYS_FAN1 ~ SYS_FAN3	システムファンヘッダー
USB0/1/2/3	バックパネル USB 2.0 ポート (タイプ A)
USB4/5	フロントパネルからアクセス可能なUSB 2.0 ヘッダー
USB6	バックパネル USB 3.2 Gen 2 ポート (10Gb、タイプ A)
USB7	バックパネル USB 3.2 Gen 2x2 ポート (20Gb、タイプ C)
USB8	バックパネル USB 3.2 Gen 2 ポート (10Gb、タイプ A)
USB9	バックパネル USB 3.2 Gen 2x2 ポート (20Gb、タイプ C)
USB10/11	フロントパネルからアクセス可能なUSB 3.2 Gen 1 ヘッダー (5Gb)
USB12	フロントパネルからアクセス可能な USB 3.2 Gen 2x2 20ピンコネクタ (20Gb)

## お問い合わせ先

- [www.supermicro.com](http://www.supermicro.com) (Eメール : [support@supermicro.com](mailto:support@supermicro.com))
- マニュアル : <http://www.supermicro.com/support/manuals>
- ドライバーおよびユーティリティ : <https://www.supermicro.com/wdl/driver/>
- 安全性 : [http://www.supermicro.com/about/policies/safety\\_information.cfm](http://www.supermicro.com/about/policies/safety_information.cfm)

## LED インジケータ

LED インジケータ		
LED	説明	カラー/状態
BOOT LED	起動可能なデバイスのPOST (電源投入時自己診断) ステータス	起動可能なデバイスのPOST : オレンジ オン 起動可能なデバイス POST 完了 : オフ
CPU LED	CPU POST (電源投入時自己診断) ステータス	CPU POST : イエロー オン CPU POST 完了 : オフ
DIMM LED	DIMM POST (電源投入時自己診断) ステータス	DIMM POST : ブルー オン DIMM POST 完了 : オフ
LED1	オンボード電源 LED S3 (スリープモード) LED	電源オン : グリーン オン S3 : グリーン 点滅
LED17	WLAN POST (電源投入時自己診断) ステータス	WLAN POST : グリーン オン WLAN POST 完了 : オフ
LED18	Bluetooth デバイスのPOST (電源投入時自己診断) ステータス	Bluetooth デバイス POST : グリーン オン Bluetooth デバイス POST 完了 : オフ
LED2	PCIe M.2-M2 ソケット LED	PCIe デバイス検知済み : グリーン オン アクティビティ : グリーン 点滅
LED3	PCIe M.2-M1 ソケット LED	PCIe デバイス検知済み : グリーン オン アクティビティ : グリーン 点滅
LED4	BIOS POST コード LED	デジタル読み出し
LED4801	PCIe M.2-M3 ソケット LED	PCIe デバイス検知済み : グリーン オン アクティビティ : グリーン 点滅
VGA LED	オンボードVGA POST (電源投入時自己診断) ステータス	オンボードVGA POST : グリーン オン オンボードVGA POST 完了 : オフ

## CPUの設置

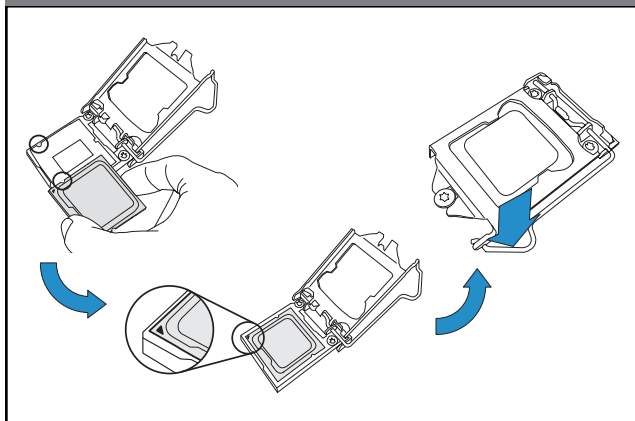

## ヒートシンクの設置方向

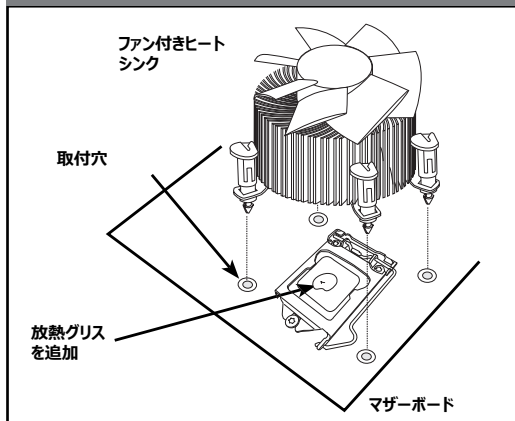

## フロントコントロールパネル (JF1)

電源 LED (-)	15	16	電源 LED (+)	15	16	POWER LED (-)	15	16	POWER LED (+)
HDD LED (-)			HDD LED (+)			HDD LED (-)			HDD LED (+)
NIC1 LED (-)			NIC1 LED (+)			NIC1 LED (-)			NIC1 LED (+)
NIC2 LED (-)			NIC2 LED (+)			NIC2 LED (-)			NIC2 LED (+)
過熱/ ファン故障 LED (-)			過熱/ ファン故障 LED (+)			Overheat/ Fan Fail LED (-)			Overheat/ Fan Fail LED (+)
X			X			X			X
接地			リセット			Ground			Reset } Reset Button
接地			電源			Ground			PWR } Power Button
	1	2					1	2	

## 注記

- 本クイック参照ガイドにある図は参考用です。お手元のコンポーネントは、本ガイドに示されている図と異なるか、まったく同一ではない可能性があります。
- 以下に関する詳細は第2章にあるユーザーマニュアルを参照してください：ジャンパー、コネクタ、LEDインジケータ、メモリサポートおよびCPU/マザーボードインストールガイド。

## CPU およびメモリサポート

C9Z590-CG-/CGWは、第11世代Intel® Core™ i9/i7/i5 シリーズプロセッサ（LGA 1200ソケット）x1基、288ピンメモリスロットx4基で、最大3200MHz（2DPC、CPU）の速度で最大128GBのバッファなし非ECC UDIMMをサポートします。これらの DIMM スロットにタイプとサイズが同じメモリモジュールのペアを装着した場合、インターリーブメモリが生成されてメモリパフォーマンスが向上します。

- 注記：1) メモリの最適化には、Supermicro によって検証済みの DIMM モジュールのみを使用してください。最新のメモリアップデートについては、当社のウェブサイト (<http://www.supermicro.com/products/motherboard>) を参照してください。
- 2) 電源コードは必ず最後につなげてください。ハードウェアコンポーネントを追加、取り外し、または変更する前には必ず抜いてください。
  - 3) 過熱は、CPUとマザーボードに深刻な損傷を与える可能性があります。CPUを過熱から保護するため、冷却ファンが適切に機能していることを常に確認してください。
  - 4) このマザーボードは第11世代コアシリーズプロセッサのみをサポートします。第10世代コアシリーズのプロセッサを使用した場合、システムは起動しません。

### DIMM メモリ設置

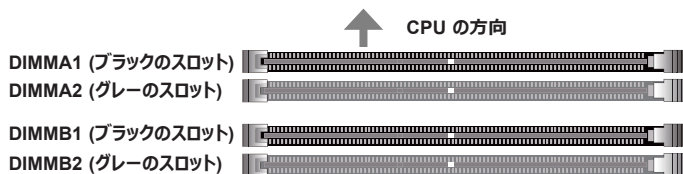

### メモリモジュール取付ガイドライン

メモリモジュールを取り付けるときは、DIMMスロットにDIMMA2、DIMMB2、DIMMA1、DIMMB1の順序で取り付ける必要があります。

- 常にサイズ、タイプおよび速度が同じ DDR4 DIMM モジュールを使用してください。
- 異なる速度の DIMM を設置できます。しかしながら、すべての DIMM が最も遅い DIMM の速度で動作します。

#### 推奨される挿入（バランス）

DIMMA1	DIMMB1	DIMMA2	DIMMB2	システムメモリ合計
		2GB DIMM	2GB DIMM	4GB
2GB DIMM	2GB DIMM	2GB DIMM	2GB DIMM	8GB
		4GB DIMM	4GB DIMM	8GB
4GB DIMM	4GB DIMM	4GB DIMM	4GB DIMM	16GB
		8GB DIMM	8GB DIMM	16GB
8GB DIMM	8GB DIMM	8GB DIMM	8GB DIMM	32GB
		16GB DIMM	16GB DIMM	32GB
16GB DIMM	16GB DIMM	16GB DIMM	16GB DIMM	64GB
		32GB DIMM	32GB DIMM	64GB
32GB DIMM	32GB DIMM	32GB DIMM	32GB DIMM	128GB

## バックパネル I/O コネクタ

1. DisplayPort 1.4a	7. Ethernet RJ45 10GbE ポート 2	13. サラウンド出力
2. HDMI ポート 2.0b	8. USB8 : USB 3.2 Gen 2 (10Gb、タイプ A)	14. S/PDIF 出力
3. USB0/1/2/3 : USB 2.0 (タイプ A)	9. USB9 : USB 3.2 Gen 2x2 (20Gb、タイプ C)	15. ライン入力
4. Ethernet RJ45 1GbE ポート 1	10. SW1 : CMOSのクリア	16. ライン出力
5. USB6 : USB 3.2 Gen 2 (10Gb、タイプ A)	11. WiFi 6+BT 5.1 (C9Z590-CGWのみ)	17. マイク入力
6. USB7 : USB 3.2 Gen 2x2 (20Gb、タイプ C)	12. センター/LFE 出力	

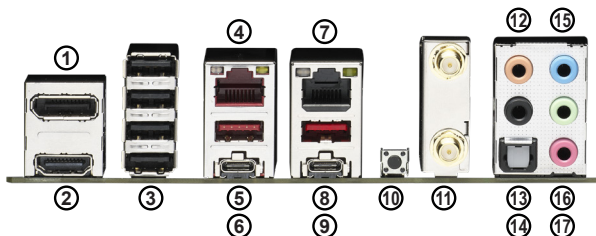

#### 마더보드 레이아웃 및 특징

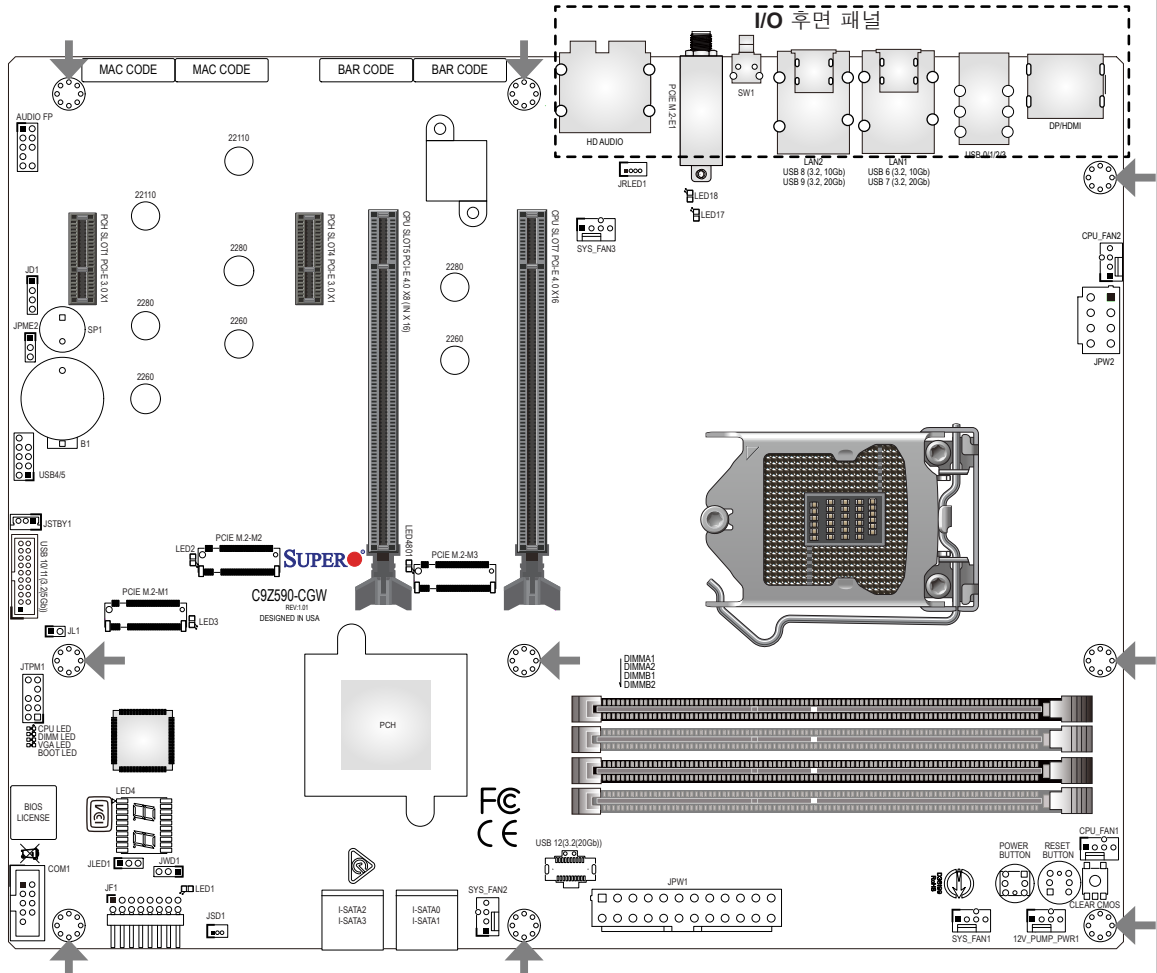

➔ = 마운팅 홀

## 제품 구성물

- Supermicro 메인보드 1개
- SATA 케이블 4개
- I/O 쉴드 1개
- S-커넥터 1개
- 간편 참조 가이드 1부
- 드라이버 CD 1개
- 안테나 2개(C9Z590-CGW만)

## 점퍼 및 커넥터

점퍼		
점퍼	설명	기본값
CLEAR CMOS	CMOS 초기화 스위치	푸시 버튼 스위치
JD1	스피커/버저	핀 1~4: 외부 스피커/핀 3~4: 버저
JPME2	Intel ME 제조 모드	핀 1~2: 정상 핀 2~3: 제조 모드
JWD1	Watch Dog 기능 활성화	핀 1~2: RST/핀 2~3: NMI
POWER BUTTON	내부 전원 버튼	푸시 버튼 스위치
RESET BUTTON	시스템 리셋 버튼	푸시 버튼 스위치
SW1	후면패널 CMOS 초기화 스위치	푸시 버튼 스위치

커넥터	
커넥터	설명
12V_PUMP_PWR1	CPU 수냉 펌프용 12V 4핀 전원 커넥터
AUDIO FP	전면 패널 오디오 헤더
B1	온보드 배터리
COM1	COM1 헤더
CPU_FAN1/CPU_FAN2	CPU 팬 헤더
CPU SLOT5 PCI-E 4.0 x8 (IN x16)	PCIe 4.0 x16 슬롯(PCIe 4.0 x8 링크) *CPU Slot5 PCIe 4.0 x8(IN x16) 슬롯은 PCIe x16 링크를 CPU Slot7 PCIe 4.0 x16 슬롯과 공유하므로 CPU Slot7 PCIe 4.0 x16 링크는 CPU Slot5 PCIe 4.0 x8 (IN x16) 슬롯에 그래픽 카드가 설치되면 PCIe 4.0 x8 링크로 변경됩니다.
CPU SLOT7 PCI-E 4.0 x16	PCIe 4.0 x16 슬롯(PCIe 4.0 x16 링크) *성능을 극대화하려면 항상 그래픽 카드 하나를 먼저 CPU Slot7 PCIe 4.0 x16 슬롯에 연결하십시오.
DP/HDMI	후면 패널 DisplayPort/HDMI
HD AUDIO	HD 오디오 포트
I-SATA0~3	(Intel Z590) 시리얼 ATA(SATA 3.0) 포트 0~3(6Gb/초)
JF1	전면 제어 패널 헤더 *Plug in시 S-커넥터에 인쇄된 표시와 JF1의 해당 핀을 맞추십시오.
JL1	새시 침입 헤더
JLED1	전원 LED 표시등 헤더
JPW1	24핀 ATX 주전원 커넥터(필수)
JPW2	+12V 8핀 CPU 전원 커넥터(필수)
JRLED1	I/O 커버 내부의 흰색 LED 보드(사전 설치됨)용 4핀 커넥터
JSD1	SATA DOM(디스크-온-모듈) 전원 커넥터
JSTBY1	5V 대기 전원 헤더
JTPM1	TPM/포트 80 헤더(TPM 2.0만 지원)
LAN1/LAN2	RJ45 1GbE/10GbE LAN 포트
PCIE M.2-E1	WiFi 6 + BT 5.1(미리 설치됨, C9Z590-CGW 전용)
PCIE M.2-M1/PCIE M.2-M2	PCH에 연결된 PCIe 3.0x4 M.2 M-키 소켓. 2260/2280/22110 모듈 NVMe SSD 저장 장치 및 RAID 0,1,5 지원.
PCIE M.2-M3	CPU에 연결된 PCIe 4.0x4 M.2 M-키 소켓. 2260/2280 모듈 NVMe SSD 저장 장치 및 RAID 0,1,5 지원.
PCH SLOT1/4 PCI-E 3.0 x1	PCIe 3.0 x1 슬롯(PCIe 3.0 x1 링크)
SP1	내부 스피커/버저
SYS_FAN1 ~ SYS_FAN3	시스템 팬 헤더
USB0/1/2/3	후면 패널 USB 2.0 포트(타입 A)
USB4/5	액세스 가능한 전면 패널 USB 2.0 헤더
USB6	후면 패널 USB 3.2 Gen 2 포트(10Gb, 타입 A)
USB7	후면 패널 USB 3.2 Gen 2x2 포트(20Gb, 타입 C)
USB8	후면 패널 USB 3.2 Gen 2 포트(10Gb, 타입 A)
USB9	후면 패널 USB 3.2 Gen 2x2 포트(20Gb, 타입 C)
USB10/11	전면 패널 액세스 가능 USB 3.2 Gen 1 헤더(5Gb)
USB12	전면 패널 액세스 가능 USB 3.2 Gen 2x2 20핀 커넥터(20Gb)

## 연락처 정보

- [www.supermicro.com](http://www.supermicro.com)(이메일: [support@supermicro.com](mailto:support@supermicro.com))
- 사용 설명서: <http://www.supermicro.com/support/manuals>
- 드라이버 및 유틸리티: <https://www.supermicro.com/wdl/driver/>
- 안전: [http://www.supermicro.com/about/policies/safety\\_information.cfm](http://www.supermicro.com/about/policies/safety_information.cfm)

## LED 표시등

### LED 표시등

LED	설명	색/상태
BOOT LED	부팅 가능한 장치 POST(전원 공급 자체 테스트) 상태	부팅 가능한 장치 POST: 주황색으로 켜짐 부팅 가능한 장치 POST 완료: 꺼짐
CPU LED	CPU POST(전원 공급 자체 테스트) 상태	CPU POST: 노란색으로 켜짐 CPU POST 완료: 꺼짐
DIMM LED	DIMM POST(전원 공급 자체 테스트) 상태	DIMM POST: 파란색으로 켜짐 DIMM POST 완료: 꺼짐
LED1	온보드 전원 LED S3 (RAM 절전 대기) LED	전원 켜짐: 녹색으로 켜짐 S3: 녹색으로 깜박거림
LED17	WLAN POST(전원 공급 자체 테스트) 상태	WLAN POST: 녹색 켜짐 WLAN POST 완료: 꺼짐
LED18	Bluetooth 장치 POST(전원 공급 자체 테스트) 상태	Bluetooth 장치 POST: 녹색 켜짐 Bluetooth 장치 POST 완료: 꺼짐
LED2	PCIe M.2-M2 소켓 LED	PCIe 장치가 감지됨: 녹색 켜짐 활동: 녹색으로 깜박거림
LED3	PCIe M.2-M1 소켓 LED	PCIe 장치가 감지됨: 녹색 켜짐 활동: 녹색으로 깜박거림
LED4	BIOS POST 코드 LED	디지털 판독
LED4801	PCIe M.2-M3 소켓 LED	PCIe 장치가 감지됨: 녹색 켜짐 활동: 녹색으로 깜박거림
VGA LED	온보드 VGA POST(전원 공급 자체 테스트) 상태	온보드 VGA POST: 녹색 켜짐 온보드 VGA POST 완료: 꺼짐

## CPU 설치

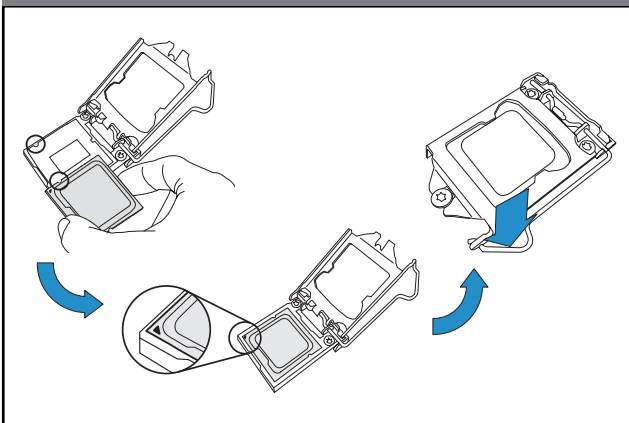

## 방열판 설치

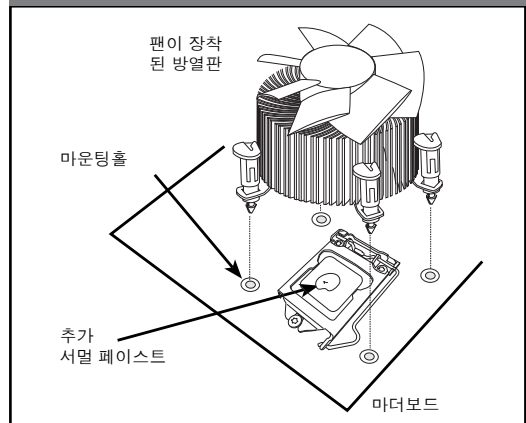

## 전면 제어 패널 (JF1)

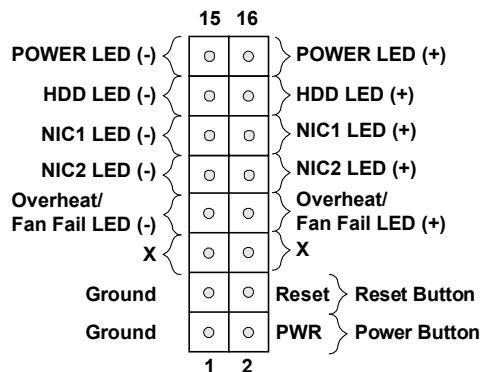
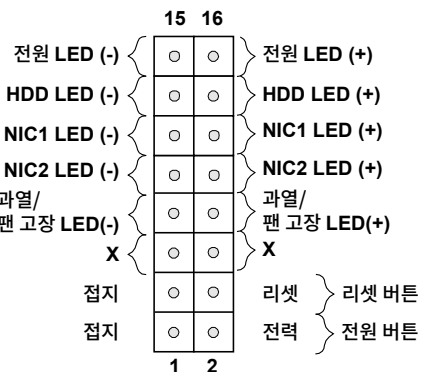

## 참고

- 이 간편 설명서의 그림들은 예시로만 사용됩니다. 실제 부품은 안내서에 표시된 도면과 동일하지 않을 수 있습니다.
- 접퍼, 커넥터, LED 표시등, 메모리 지원 및 CPU /메인보드 설치 지침에 대한 자세한 내용은 사용 설명서의 2장을 참조하십시오.

## CPU 및 메모리 지원

C9Z590-CG-/CGW(는) 4개의 288핀 메모리 슬롯에서 속도가 최대 3200MHz이고 최대 128GB의 버퍼링된 지원 않는 비ECC UDIMM(2DPC, CPU에서)인 단일 11세대 Intel® Core™ i9/i7/i5 시리즈 프로세서(LGA1200 소켓)를 지원합니다. DIMM 슬롯에 동일한 유형 및 크기의 메모리 모듈 쌍을 채우면 인터리브 메모리가 발생하여 메모리 성능이 향상됩니다.

- 참고: 1) 메모리 최적화를 위해 반드시 Supermicro의 인증을 받은 DIMM 모듈을 사용해야 합니다. 최신 메모리 업데이트 당사 웹사이트본사 웹사이트 <http://www.supermicro.com/products/motherboard>를 참조하십시오.
- 2) 전원 코드는 반드시 마지막에 연결하고 하드웨어 구성품을 추가, 제거 또는 변경하기 전에는 반드시 전원 코드를 뽑아야 합니다.
- 3) 과열은 CPU 및 메인보드에 심각한 손상을 줄 수 있습니다. 항상 냉각 팬 기능이 CPU를 과열로부터 제대로 방지하는지 확인하십시오.
- 4) 이 마더보드는 11세대 코어 시리즈 프로세서만 지원합니다. 10세대 코어 시리즈 프로세서를 사용할 경우 시스템이 부팅되지 않습니다.

### DIMM 메모리 설치

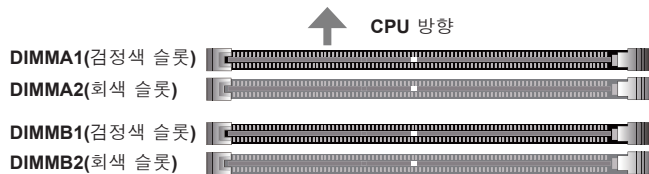

#### 메모리 설치 가이드라인

메모리 모듈을 설치할 때 DIMM 슬롯 삽입시 다음 순서를 따라야 합니다. DIMMA2, DIMMB2, 그 다음에 DIMMA1, DIMMB1.

- 항상 동일한 크기, 유형, 속도의 DDR4 DIMM 모듈을 사용하십시오.
- 혼합된 DIMM 속도를 설치해도 됩니다. 그러나 모든 DIMM가 가장 느린 DIMM 속도로 작동하게 됩니다.

DIMM 슬롯 삽입 권장 (균형)

DIMMA1	DIMMB1	DIMMA2	DIMMB2	총 시스템 메모리
		2GB DIMM	2GB DIMM	4GB
2GB DIMM	2GB DIMM	2GB DIMM	2GB DIMM	8GB
		4GB DIMM	4GB DIMM	8GB
4GB DIMM	4GB DIMM	4GB DIMM	4GB DIMM	16GB
		8GB DIMM	8GB DIMM	16GB
8GB DIMM	8GB DIMM	8GB DIMM	8GB DIMM	32GB
		16GB DIMM	16GB DIMM	32GB
16GB DIMM	16GB DIMM	16GB DIMM	16GB DIMM	64GB
		32GB DIMM	32GB DIMM	64GB
32GB DIMM	32GB DIMM	32GB DIMM	32GB DIMM	128GB

## 후면 패널 I/O 커넥터

1. 디스플레이포트 1.4a	7. 이더넷 RJ45 10GbE 포트 2	13. 서라운드 출력
2. HDMI 포트 2.0b	8. USB8: USB 3.2 Gen 2(10Gb, 타입 A)	14. S/PDIF 출력
3. USB0/1/2/3: USB 2.0(타입 A)	9. USB9: USB 3.2 Gen 2x2(20Gb, 타입 C)	15. 라인 입력
4. 이더넷 RJ45 1GbE 포트 1	10. SW1: CMOS 초기화	16. 라인 출력
5. USB6: USB 3.2 Gen 2(10Gb, 타입 A)	11. WiFi 6+BT 5.1(C9Z590-CGW만)	17. 마이크 입력
6. USB7: USB 3.2 Gen 2x2(20Gb, 타입 C)	12. 중앙/LFE 출력	

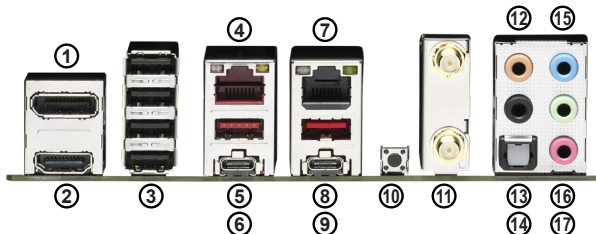

---

---

## Notes





**SUPER**  <sup>TM</sup>

**Server Quality, Built for Gaming**

**QUICK REFERENCE GUIDE**

Revision 1.0a