



SUPER™

Server Quality, Built for Gaming

C9Z890-MW

C9B860-MW

C9Q870-M

ENGLISH

繁體中文

简体中文

日本語

한국어

QUICK REFERENCE GUIDE

Revision 1.0c

Standardized Warning Statements

Motherboards

About Standardized Warning Statements

The following statements are industry standard warnings, provided to warn the user of situations which can potentially cause a bodily injury. Should you have questions or experience difficulty, contact Supermicro's Technical Support Department for assistance. Only certified technicians should attempt to install or configure components.

Read this section in its entirety before installing or configuring components in the Supermicro chassis.



WARNING: This product can expose you to chemicals including lead, known to the State of California to cause cancer and birth defects or other reproductive harm. For more information, go to www.P65Warnings.ca.gov.

Battery Handling



Warning!

There is a danger of explosion if the battery is replaced incorrectly. Replace the battery only with the same or an equivalent type recommended by the manufacturer. Dispose of used batteries according to the manufacturer's instructions.

警告

電池更換不當會有爆炸危險。請使用製造商建議之相同或功能相當的電池更換原有電池。請按照製造商的說明指示處理廢棄舊電池。

警告

電池更換不當會有爆炸危險。請只使用同類電池或製造商推薦的功能相當的電池更換原有電池。請按製造商的說明處理廢舊電池。

電池の取り扱い

電池交換が正しく行われなかった場合、破裂の危険性があります。交換する電池はメーカーが推奨する型、または同等のものを使用下さい。使用済電池は製造元の指示に従って処分して下さい。

경고!

배터리가 올바르게 교체되지 않으면 폭발의 위험이 있습니다. 기존 배터리와 동일하거나 제조사에서 권장하는 동등한 종류의 배터리로만 교체해야 합니다. 제조사의 안내에 따라 사용된 배터리를 처리하여 주십시오.

هناك خطر من انفجار في حالة استبدال البطارية بطريقة غير صحيحة فعليك استبدال البطارية فقط بنفس النوع أو ما يعادلها كما أوصت به الشركة المصنعة تخلص من البطاريات المستعملة وفقا لتعليمات الشركة الصانعة

限用物質含有情況標示聲明書

Declaration of the Presence Condition of the Restricted Substances Marking

設備名稱：主機板 / Motherboard Equipment name						
型號（型式）：C9Z890-MW, C9Q870-M, C9B860-MW Type designation (Type)						
單元 Unit	限用物質及其化學符號 Restricted substances and its chemical symbols					
	鉛Lead (Pb)	汞Mercury (Hg)	鎘Cadmium (Cd)	六價鉻 Hexavalent chromium (Cr ⁺⁶)	多溴聯苯 Polybrominated biphenyls (PBB)	多溴二苯醚 Polybrominated diphenyl ethers (PBDE)
印刷電路板 組件 (PCBA)	—	○	○	○	○	○
連接器 (Connector)	—	○	○	○	○	○
備考1. “超出0.1 wt %” 及 “超出0.01 wt %” 係指限用物質之百分比含量超出百分比含量基準值。 Note 1 : “Exceeding 0.1 wt %” and “exceeding 0.01 wt %” indicate that the percentage content of the restricted substance exceeds the reference percentage value of presence condition.						
備考2. “○” 係指該項限用物質之百分比含量未超出百分比含量基準值。 Note 2 : “○” indicates that the percentage content of the restricted substance does not exceed the percentage of reference value of presence.						
備考3. “—” 係指該項限用物質為排除項目。 Note 3 : The “—” indicates that the restricted substance corresponds to the exemption.						

AMI BIOS POST Codes

About AMI BIOS POST Codes

The table below lists some of AMI BIOS POST codes for this motherboard. For more information, refer to https://www.supermicro.com/manuals/other/AMI_AptioV_BIOS_POST_Codes_for_SM_Motherboards.pdf.

Code	Description
0x32	CPU post-memory initialization is started
0x55	No Memory detected or memory failed
0x63	CPU DXE initialization is started
0x69	North Bridge DXE initialization is started
0x70	South Bridge DXE initialization is started
0x92	PCI Bus initialization is started
0x99	Super IO Initialization
0x9A	USB initialization is started
0xA0	IDE initialization is started
0xA9	Boot into BIOS setup menu
0xAE	Legacy Boot event
0xB2	Legacy Option ROM Initialization
0xB4	USB hot plug
0xD6	No console output devices are found
0xD7	No console input devices are found
0xF2	Recovery process started
0xF9	Recovery capsule is not found

M.2 Device Installation

M.2 Device Installation

This motherboard has one PCIe 5.0 M.2 M-key slot (M.2-C1) that supports the M.2 2280/22110 modules and one PCIe 4.0 M.2 M-key slot (M.2-P1) that supports the 2260/2280 modules.

Two standoffs are pre-installed in the positions of 2280 mounting holes.

Refer to the illustration on the right for the locations of M.2 slots and mounting holes. Follow the steps below to install the M.2 device.

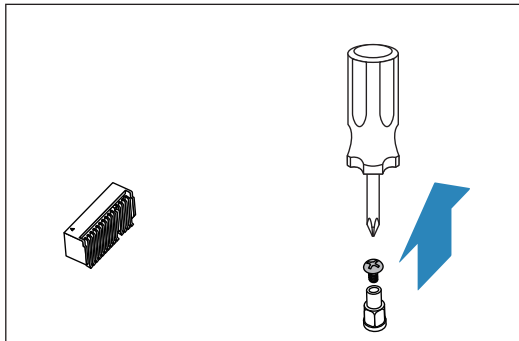
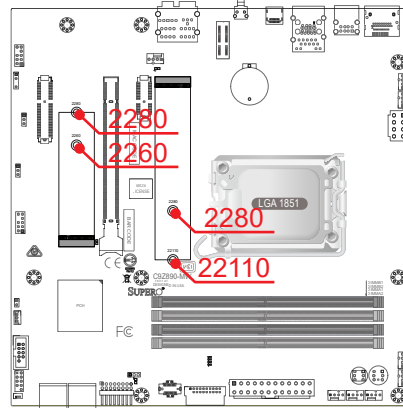

1. Locate the screw on the pre-installed standoff. Remove the screw and set it aside.

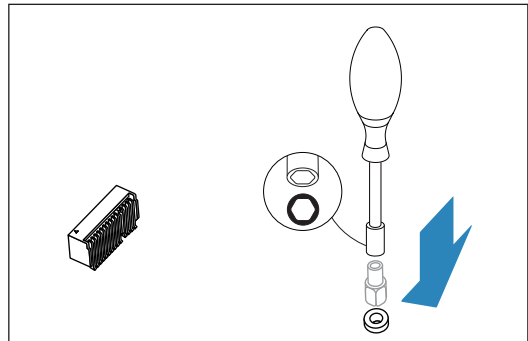

2. If the soon-to-be used mounting hole doesn't have a standoff, move the pre-installed one to that mounting hole.

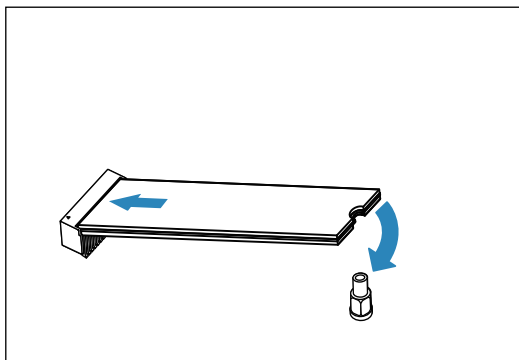

3. Carefully insert the M.2 device into the M.2 slot at a 30-degree angle and lower the semi-circle notched end onto the standoff.

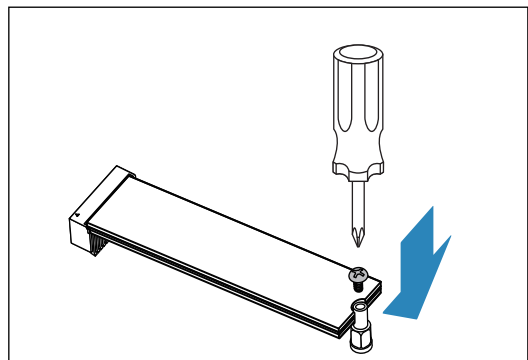

4. Tighten the standoff screw to secure the M.2 device into place. Do not over-tighten so as to avoid damaging the M.2 device.

Audio Configuration



Audio Configuration				
	2 Channel	4.1 Channel	5.1 Channel	7.1 Channel
① Orange (Center / LFE Out)			Center / Subwoofer	Center / Subwoofer
② Black (Surround)		Rear Speaker Out	Rear Speaker Out	Rear Speaker Out
③ Light Blue (Line In / Side Speaker Out)	Line In	Line In	Line In	Side Speaker Out
④ Lime (Line Out / Front Speaker Out)	Line Out	Front Speaker Out	Front Speaker Out	Front Speaker Out
⑤ Pink (Mic In)	Mic In	Mic In	Mic In	Mic In

Motherboard Layout and Features

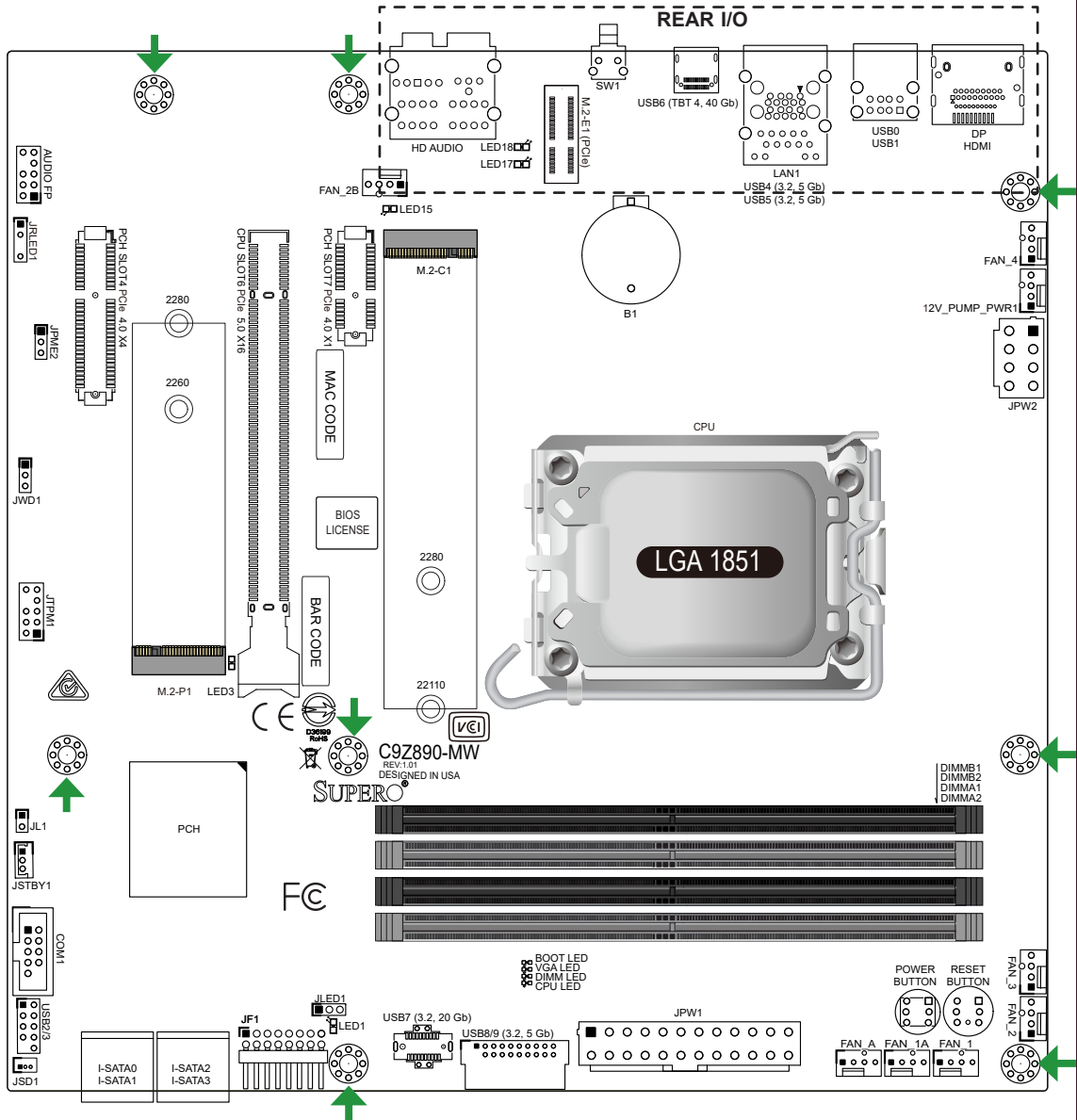

Differences between C9Z890-MW, C9B860-MW, and C9Q870-M

	C9Z890-MW	C9B860-MW	C9Q870-M
WiFi 7 + Bluetooth 5.4 Module	Yes	Yes	N/A
PCH Chipset	Intel Z890	Intel B860	Intel Q870
LAN Controller	Intel Ethernet i219-V	Intel Ethernet i219-V	Intel Ethernet i219-LM
Overclocking Support	Yes (CPU and Memory)	Yes (Memory)	N/A

➔ = mounting hole

PACKAGE CONTENTS

- One Supermicro Motherboard
- Four SATA Cables
- One S-Connector
- One I/O Shield
- One Quick Reference Guide
- Two Antennas (C9Z890-MW and C9B860-MW only)

Jumpers and Connectors

Jumpers		
Jumper	Description	Default
JPME2	Intel® Manufacturing Mode	Pins 1–2: Normal
JWD1	Watchdog Function Enable	Pins 1–2: Reset
POWER BUTTON	Internal Power Button	Push Button Switch
RESET BUTTON	Onboard System Reset Button	Push Button Switch
SW1	Rear Clear CMOS Button	Push Button Switch

Connectors	
Connector	Description
12V_PUMP_PWR1	12 V 4-pin Power Connector (for CPU liquid cooling pump)
AUDIO FP	Front Audio Header * This header is designed for a headphone/microphone combo jack. If using a standalone microphone, use the MIC jack on the rear panel. * Standalone headphone and microphone jacks are provided on the rear panel.
B1	Onboard Battery
COM1	COM Header
DP	Rear DisplayPort 2.1 (supports data rates of up to 10 Gbps)
FAN_1, FAN_A, FAN_1A, FAN_2B, FAN_2–FAN_4	FAN_1, FAN_A, FAN_1A, FAN_2B: System Fan Headers FAN_2–FAN_4: CPU Fan Headers
HD AUDIO	High Definition Audio Ports
HDMI	High Definition Multimedia Interface 2.1 (supports data rates of up to 8 Gbps)
I-SATA0–I-SATA3	Intel SATA 3.0 Ports (from PCH, 6 Gbps, with support of RAID 0/1/5/10)
JF1	Front Control Panel Header * Please align the printed indications on the S-Connector with the corresponding pins on JF1 when plugging in.
JL1	Chassis Intrusion Header
JLED1	3-pin Power LED Indicator Header
JPW1	24-pin ATX Main Power Connector (Required)
JPW2	+12 V 8-pin CPU Power Connector (Required)
JRLED1	5 V 3-pin Addressable RGB (ARGB) LED Connection Header * For the 5 V 3-pin ARGB LED connection only.
JSD1	SATA Disk-On-Module (DOM) Power Connector
JSTBY1	5 V Standby Power Header
JTPM1	Trusted Platform Module (TPM)/Port 80 Header (TPM 2.0 only)
LAN1	RJ45 1 GbE LAN Port
M.2-C1	PCIe 5.0 x4 M.2 M-Key Slot (from CPU, with support of 2280 and 22110 form factors and RAID 0/1)
M.2-E1 (PCIe)	WiFi 7 and Bluetooth 5.4 (pre-installed, C9Z890-MW and C9B860-MW only)
M.2-P1	PCIe 4.0 x4 M.2 M-Key Slot (from PCH, with support of 2260 and 2280 form factors and RAID 0/1)
SLOT4	PCIe 4.0 x4 Slot (from PCH)
SLOT6	PCIe 5.0 x16 Slot (from CPU)
SLOT7	PCIe 4.0 x1 Slot (from PCH)
USB0, USB1	Rear USB 2.0 Ports (Type-A)
USB2/3	Front Accessible USB 2.0 Header
USB4, USB5	Rear USB 3.2 Gen 1x1 Ports (5 Gb, Type-A)
USB6	Rear Thunderbolt™ 4 (TBT 4) Port (40 Gb, Type-C)
USB7	Front Accessible USB 3.2 Gen 2x2 Header (20 Gb, Type-C)
USB8/9	Front Accessible USB 3.2 Gen 1x1 Header (5 Gb, Type-A)

CONTACT INFORMATION

- www.supermicro.com (Email: support@supermicro.com)
- Manuals: <https://www.supermicro.com/support/manuals>
- Drivers & Utilities: <https://www.supermicro.com/wdl/driver/>
- Safety: https://www.supermicro.com/about/policies/safety_information.cfm

LED Indicators

LED Indicators		
LED	Description	Color/State
BOOT LED	Bootable Device Power-On Self-Test (POST) Status	Orange ON: Bootable Device POST OFF: Bootable Device POST Completion
CPU LED	CPU Power-On Self-Test (POST) Status	Yellow ON: CPU POST OFF: CPU POST Completion
DIMM LED	DIMM Power-On Self-Test (POST) Status	Blue ON: DIMM POST OFF: DIMM POST Completion
LED1	Onboard Power LED S3 (Suspend to RAM) LED	Green On: Power On Green Blinking: S3
LED17	WLAN Power-On Self-Test (POST) Status	Green ON: WLAN POST OFF: WLAN POST Completion
LED18	Bluetooth Device Power-On Self-Test (POST) Status	Green ON: Bluetooth Device POST OFF: Bluetooth Device POST Completion
LED3, LED15	M.2 LEDs for M.2-P1 / M.2-C1	Green ON: PCIe Device Detected Green Blinking: Activity
VGA LED	Onboard VGA Power-On Self-Test (POST) Status	Green ON: Onboard VGA POST OFF: Onboard VGA POST Completion

CPU Installation

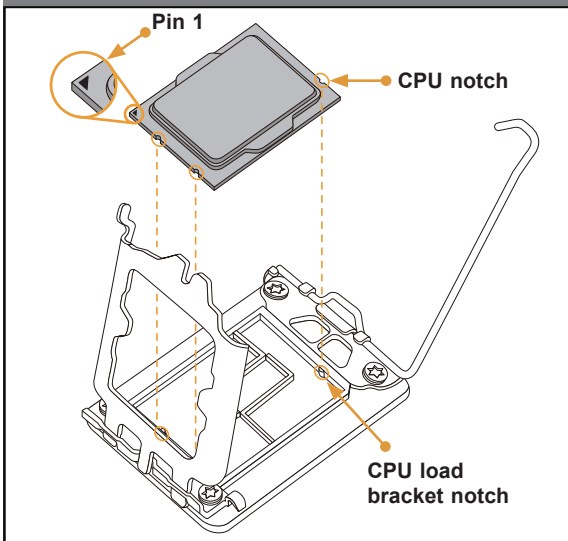

Heatsink Installation

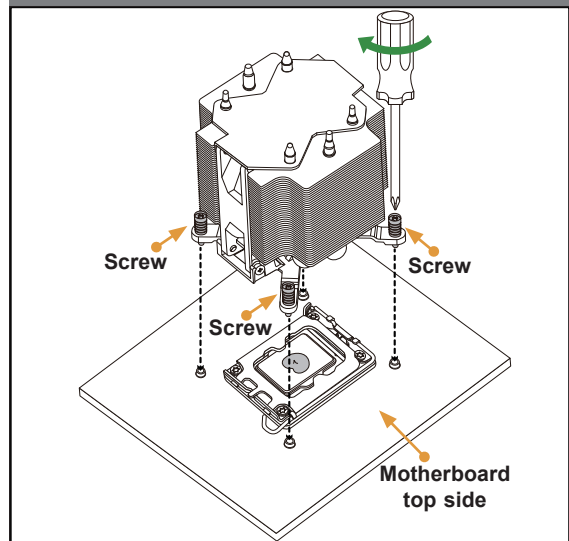

Front Control Panel (JF1)

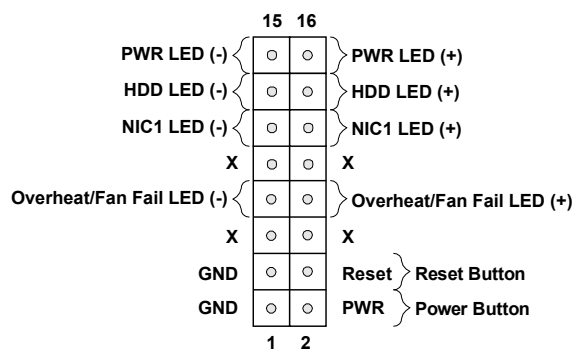

NOTES

- Graphics shown in this quick reference guide are for illustration only. Your components may or may not look exactly the same as drawings shown in this guide.
- Refer to User's Manual for detailed information on jumpers, connectors, LED indicators, memory support and CPU/motherboard installation instructions.

CPU & Memory Support

The C9Z890-MW/C9B860-MW/C9Q870-M supports a single Intel Core™ Ultra 200S (Ultra 9/7/5) or Core Ultra 200S Plus (Ultra 7/5) processor (LGA 1851, Socket V1), up to DDR5 256 GB of non-ECC Unbuffered DIMM (UDIMM) and Clocked Unbuffered DIMM (CUDIMM) with speeds of up to 5600 MT/s (1DPC) in four 288-pin memory slots. Populating these DIMM slots with a pair of memory modules of the same type and size will result in interleaved memory, which will improve memory performance.

Notes: 1) For memory optimization, use only DIMM modules that have been validated by Supermicro. For the latest memory updates, please refer to our website at <https://www.supermicro.com/products/motherboard>.

2) Always connect the power cord last, and always remove it before adding, removing or changing any hardware components.

3) Overheating can seriously damage CPU and motherboard. Always make sure cooling fans function properly to protect CPU from overheating.

DIMM Memory Installation



Towards the CPU



Memory Population Guidelines

When installing memory modules, the DIMM slots should be populated in the following order: DIMMB2, DIMMA2, DIMMB1, DIMMA1.

- To optimize memory performance, please use (DDR5) memory of the same type, size, and speed on the motherboard.
- Mixed DIMM speeds can be installed. However, all DIMMs will run at the speed of slowest DIMM.
- The DDR5 DIMM module is NOT hot-swappable and be sure to disconnect power for a minimum of 20 seconds before inserting or removing it.
- Removing a DDR5 DIMM module at a slanted angle will cause damages. It is strongly recommended that you lift the module straight up out of the slot.

Memory Support				Recommended Population (Balanced)				
Frequency	4400 MT/s (2DPC)	4800 MT/s (2DPC)	5600 MT/s (1DPC)	DIMMA1	DIMMB1	DIMMA2	DIMMB2	Total System Memory
DIMMA1	2R DIMM	1R DIMM	N/A			8 GB DIMM	8 GB DIMM	16 GB
DIMMA2	2R DIMM	1R DIMM	1R or 2R DIMM			16 GB DIMM	16 GB DIMM	32 GB
DIMMB1	2R DIMM	1R DIMM	N/A			24 GB DIMM	24 GB DIMM	48 GB
DIMMB2	2R DIMM	1R DIMM	1R or 2R DIMM			32 GB DIMM	32 GB DIMM	64 GB
						48 GB DIMM	48 GB DIMM	96 GB
						64 GB DIMM	64 GB DIMM	128 GB
						8 GB DIMM	8 GB DIMM	16 GB
						16 GB DIMM	16 GB DIMM	32 GB
						24 GB DIMM	24 GB DIMM	48 GB
						32 GB DIMM	32 GB DIMM	64 GB
						48 GB DIMM	48 GB DIMM	96 GB
						64 GB DIMM	64 GB DIMM	128 GB
						8 GB DIMM	8 GB DIMM	16 GB
						16 GB DIMM	16 GB DIMM	32 GB
						24 GB DIMM	24 GB DIMM	48 GB
						32 GB DIMM	32 GB DIMM	64 GB
						48 GB DIMM	48 GB DIMM	96 GB
						64 GB DIMM	64 GB DIMM	128 GB
						8 GB DIMM	8 GB DIMM	16 GB
						16 GB DIMM	16 GB DIMM	32 GB
						24 GB DIMM	24 GB DIMM	48 GB
						32 GB DIMM	32 GB DIMM	64 GB
						48 GB DIMM	48 GB DIMM	96 GB
						64 GB DIMM	64 GB DIMM	128 GB
						8 GB DIMM	8 GB DIMM	16 GB
						16 GB DIMM	16 GB DIMM	32 GB
						24 GB DIMM	24 GB DIMM	48 GB
						32 GB DIMM	32 GB DIMM	64 GB
						48 GB DIMM	48 GB DIMM	96 GB
						64 GB DIMM	64 GB DIMM	128 GB
						8 GB DIMM	8 GB DIMM	16 GB
						16 GB DIMM	16 GB DIMM	32 GB
						24 GB DIMM	24 GB DIMM	48 GB
						32 GB DIMM	32 GB DIMM	64 GB
						48 GB DIMM	48 GB DIMM	96 GB
						64 GB DIMM	64 GB DIMM	128 GB
						8 GB DIMM	8 GB DIMM	16 GB
						16 GB DIMM	16 GB DIMM	32 GB
						24 GB DIMM	24 GB DIMM	48 GB
						32 GB DIMM	32 GB DIMM	64 GB
						48 GB DIMM	48 GB DIMM	96 GB
						64 GB DIMM	64 GB DIMM	128 GB
						8 GB DIMM	8 GB DIMM	16 GB
						16 GB DIMM	16 GB DIMM	32 GB
						24 GB DIMM	24 GB DIMM	48 GB
						32 GB DIMM	32 GB DIMM	64 GB
						48 GB DIMM	48 GB DIMM	96 GB
						64 GB DIMM	64 GB DIMM	128 GB
						8 GB DIMM	8 GB DIMM	16 GB
						16 GB DIMM	16 GB DIMM	32 GB
						24 GB DIMM	24 GB DIMM	48 GB
						32 GB DIMM	32 GB DIMM	64 GB
						48 GB DIMM	48 GB DIMM	96 GB
						64 GB DIMM	64 GB DIMM	128 GB
						8 GB DIMM	8 GB DIMM	16 GB
						16 GB DIMM	16 GB DIMM	32 GB
						24 GB DIMM	24 GB DIMM	48 GB
						32 GB DIMM	32 GB DIMM	64 GB
						48 GB DIMM	48 GB DIMM	96 GB
						64 GB DIMM	64 GB DIMM	128 GB
						8 GB DIMM	8 GB DIMM	16 GB
						16 GB DIMM	16 GB DIMM	32 GB
						24 GB DIMM	24 GB DIMM	48 GB
						32 GB DIMM	32 GB DIMM	64 GB
						48 GB DIMM	48 GB DIMM	96 GB
						64 GB DIMM	64 GB DIMM	128 GB
						8 GB DIMM	8 GB DIMM	16 GB
						16 GB DIMM	16 GB DIMM	32 GB
						24 GB DIMM	24 GB DIMM	48 GB
						32 GB DIMM	32 GB DIMM	64 GB
						48 GB DIMM	48 GB DIMM	96 GB
						64 GB DIMM	64 GB DIMM	128 GB
						8 GB DIMM	8 GB DIMM	16 GB
						16 GB DIMM	16 GB DIMM	32 GB
						24 GB DIMM	24 GB DIMM	48 GB
						32 GB DIMM	32 GB DIMM	64 GB
						48 GB DIMM	48 GB DIMM	96 GB
						64 GB DIMM	64 GB DIMM	128 GB
						8 GB DIMM	8 GB DIMM	16 GB
						16 GB DIMM	16 GB DIMM	32 GB
						24 GB DIMM	24 GB DIMM	48 GB
						32 GB DIMM	32 GB DIMM	64 GB
						48 GB DIMM	48 GB DIMM	96 GB
						64 GB DIMM	64 GB DIMM	128 GB
						8 GB DIMM	8 GB DIMM	16 GB
						16 GB DIMM	16 GB DIMM	32 GB
						24 GB DIMM	24 GB DIMM	48 GB
						32 GB DIMM	32 GB DIMM	64 GB
						48 GB DIMM	48 GB DIMM	96 GB
						64 GB DIMM	64 GB DIMM	128 GB
						8 GB DIMM	8 GB DIMM	16 GB
						16 GB DIMM	16 GB DIMM	32 GB
						24 GB DIMM	24 GB DIMM	48 GB
						32 GB DIMM	32 GB DIMM	64 GB
						48 GB DIMM	48 GB DIMM	96 GB
						64 GB DIMM	64 GB DIMM	128 GB
						8 GB DIMM	8 GB DIMM	16 GB
						16 GB DIMM	16 GB DIMM	32 GB
						24 GB DIMM	24 GB DIMM	48 GB
						32 GB DIMM	32 GB DIMM	64 GB
						48 GB DIMM	48 GB DIMM	96 GB
						64 GB DIMM	64 GB DIMM	128 GB
						8 GB DIMM	8 GB DIMM	16 GB
						16 GB DIMM	16 GB DIMM	32 GB
						24 GB DIMM	24 GB DIMM	48 GB
						32 GB DIMM	32 GB DIMM	64 GB
						48 GB DIMM	48 GB DIMM	96 GB
						64 GB DIMM	64 GB DIMM	128 GB
						8 GB DIMM	8 GB DIMM	16 GB
						16 GB DIMM	16 GB DIMM	32 GB
						24 GB DIMM	24 GB DIMM	48 GB
						32 GB DIMM	32 GB DIMM	64 GB
						48 GB DIMM	48 GB DIMM	96 GB
						64 GB DIMM	64 GB DIMM	128 GB
						8 GB DIMM	8 GB DIMM	16 GB
						16 GB DIMM	16 GB DIMM	32 GB
						24 GB DIMM	24 GB DIMM	48 GB
						32 GB DIMM	32 GB DIMM	64 GB
						48 GB DIMM	48 GB DIMM	96 GB
						64 GB DIMM	64 GB DIMM	128 GB
						8 GB DIMM	8 GB DIMM	16 GB
						16 GB DIMM	16 GB DIMM	32 GB
						24 GB DIMM	24 GB DIMM	48 GB
						32 GB DIMM	32 GB DIMM	64 GB
						48 GB DIMM	48 GB DIMM	96 GB
						64 GB DIMM	64 GB DIMM	128 GB
						8 GB DIMM	8 GB DIMM	16 GB
						16 GB DIMM	16 GB DIMM	32 GB
						24 GB DIMM	24 GB DIMM	48 GB
						32 GB DIMM	32 GB DIMM	64 GB
						48 GB DIMM	48 GB DIMM	96 GB
						64 GB DIMM	64 GB DIMM	128 GB
						8 GB DIMM	8 GB DIMM	16 GB
						16 GB DIMM	16 GB DIMM	32 GB
						24 GB DIMM	24 GB DIMM	48 GB
						32 GB DIMM	32 GB DIMM	64 GB
						48 GB DIMM	48 GB DIMM	96 GB
						64 GB DIMM	64 GB DIMM	128 GB
						8 GB DIMM	8 GB DIMM	16 GB
						16 GB DIMM	16 GB DIMM	32 GB
						24 GB DIMM	24 GB DIMM	48 GB
						32 GB DIMM	32 GB DIMM	64 GB
						48 GB DIMM	48 GB DIMM	96 GB
						64 GB DIMM	64 GB DIMM	128 GB
						8 GB DIMM	8 GB DIMM	16 GB
						16 GB DIMM	16 GB DIMM	32 GB
						24 GB DIMM	24 GB DIMM	48 GB
						32 GB DIMM	32 GB DIMM	64 GB
						48 GB DIMM	48 GB DIMM	96 GB
						64 GB DIMM	64 GB DIMM	128 GB
						8 GB DIMM	8 GB DIMM	16 GB
						16 GB DIMM	16 GB DIMM	32 GB
						24 GB DIMM	24 GB DIMM	48 GB
						32 GB DIMM	32 GB DIMM	64 GB
						48 GB DIMM	48 GB DIMM	96 GB
						64 GB DIMM	64 GB DIMM	128 GB
						8 GB DIMM	8 GB DIMM	16 GB
						16 GB DIMM	16 GB DIMM	32 GB
						24 GB DIMM	24 GB DIMM	48 GB
						32 GB DIMM	32 GB DIMM	64 GB
						48 GB DIMM	48 GB DIMM	96 GB
						64 GB DIMM	64 GB DIMM	128 GB

主機板元件配置圖

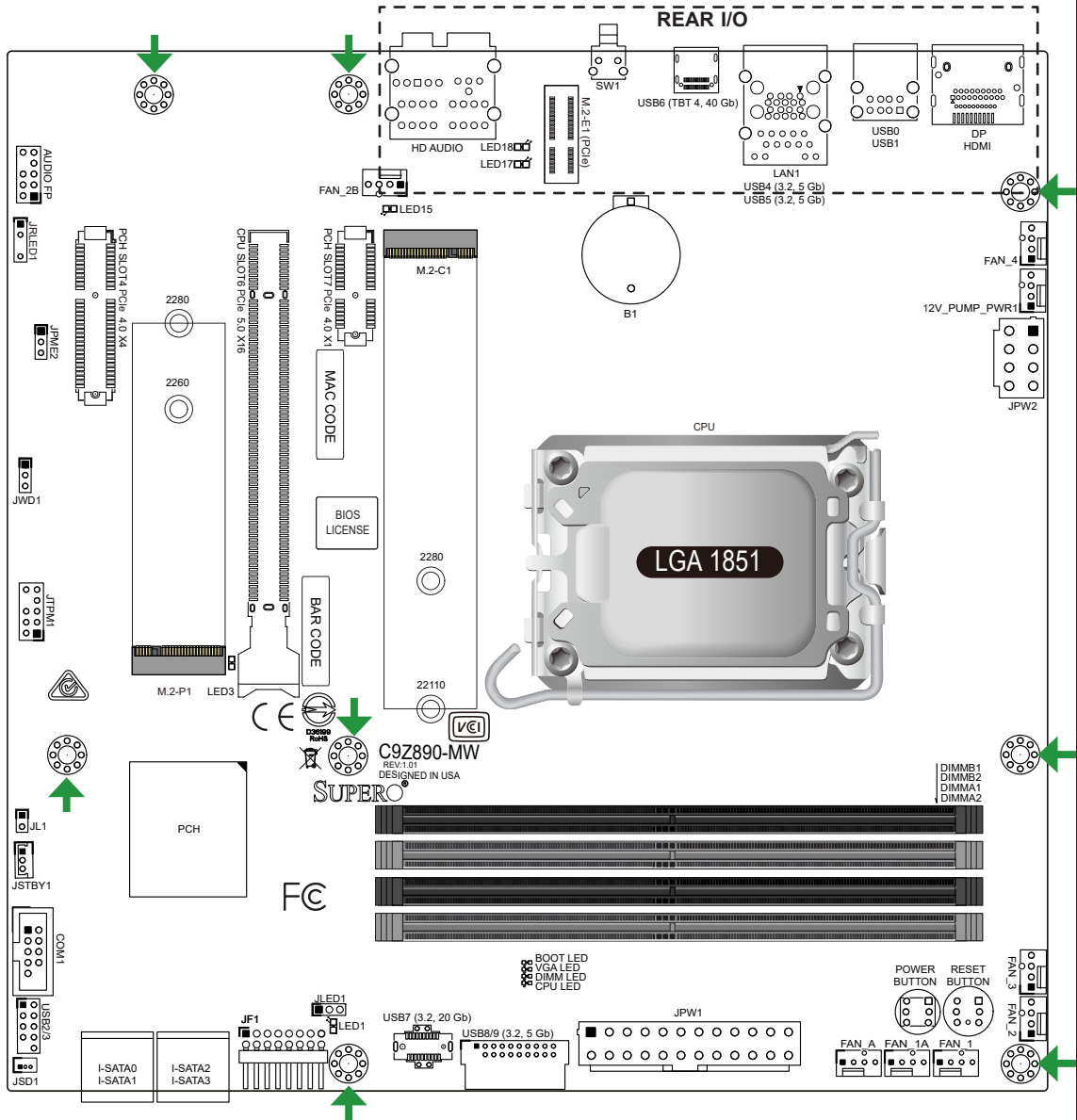

Differences between C9Z890-MW, C9B860-MW, and C9Q870-M

	C9Z890-MW	C9B860-MW	C9Q870-M
WiFi 7 + Bluetooth 5.4 Module	Yes	Yes	N/A
PCH Chipset	Intel Z890	Intel B860	Intel Q870
LAN Controller	Intel Ethernet i219-V	Intel Ethernet i219-V	Intel Ethernet i219-LM
Overclocking Support	Yes (CPU and Memory)	Yes (Memory)	N/A

➔ = 裝機孔

單一主機板包裝盒內容清單

- Supermicro 主機板 x1
- SATA 訊號線 x4
- S-轉接器 (S-Connector) x1
- I/O 後擋板 x1
- 快速參考指南 x1
- 天線 x2 (僅限 C9Z890-MW 和 C9B860-MW)

跳線器/連接埠

跳線器		
跳線器	說明	預設值
JPME2	Intel® 製造模式	針腳 1-2 (正常)
JWD1	啟用系統監控 (Watchdog) 功能	針腳 1-2 (重設)
POWER BUTTON	(板上) 電源開關	按鍵式開關
RESET BUTTON	(板上) 系統重設開關	按鍵式開關
SW1	(背板) CMOS 組態資料清除開關	按鍵式開關

連接埠	
連接埠	說明
12V_PUMP_PWR1	12伏 4針腳水冷幫浦電源插座
AUDIO FP	前面板音效接頭 * 主要支援耳機/麥克風組合插孔。如要使用單獨的麥克風裝置，請連接背板的麥克風插孔。 * 背板備有獨立的耳機與麥克風插孔。
B1	內建電池
COM1	COM 序列連接埠接頭
DP	背板 DisplayPort 2.1 連接埠 (最高支援 10 Gbps 的傳輸速率)
FAN_1, FAN_A, FAN_1A, FAN_2B, FAN_2-FAN_4	FAN_1, FAN_A, FAN_1A, FAN_2B : 系統風扇接頭 FAN_2-FAN_4 : 中央處理器風扇接頭
HD AUDIO	背板高清晰音效插孔
HDMI	高清晰度多媒體介面 (HDMI 2.1) 連接埠 (最高支援 8 Gbps 的傳輸速率)
I-SATA0-I-SATA3	Intel 序列 ATA 介面 (SATA 3.0) 連接埠 (源自 PCH、6 Gbps、支援 RAID 0/1/5/10)
JF1	前控制面板接頭 * 請參照 S-轉接器 (S-Connector) 上的印刷標示連接對應的 JF1 針腳。
JL1	機殼防盜裝置接頭
JLED1	3針腳電源指示燈接頭
JPW1	24針腳 ATX 主電源連接埠 (必備)
JPW2	+12伏 8針腳 CPU 電源連接埠 (必備)
JRLED1	5伏 3針腳 Addressable RGB (ARGB) LED 裝置接頭 * JRLED1 僅限連接 5伏 3針腳 ARGB LED 裝置。
JSD1	SATA Disk-On-Module (DOM) 磁碟模組電源連接埠
JSTBY1	5伏待機電源接頭
JTPM1	TPM 信任平台模組/Port 80 接頭 (僅支援 TPM 2.0)
LAN1	RJ45 1 GbE 網路線連接埠
M.2-C1	PCIe 5.0 x4 M.2 M-Key 裝置連接埠 (源自 CPU、支援 2280/22110 尺寸 M.2 模組規格與 RAID 0/1)
M.2-E1 (PCIe)	無線網路 WiFi 7 和藍芽 Bluetooth 5.4 (已預先安裝、僅限 C9Z890-MW 和 C9B860-MW)
M.2-P1	PCIe 4.0 x4 M.2 M-Key 裝置連接埠 (源自 PCH、支援 2260/2280 尺寸 M.2 模組規格與 RAID 0/1)
SLOT4	PCIe 4.0 x4 插槽 (源自 PCH)
SLOT6	PCIe 5.0 x16 插槽 (源自 CPU)
SLOT7	PCIe 4.0 x1 插槽 (源自 PCH)
USB0, USB1	背板 USB 2.0 規格連接埠 (Type-A)
USB2/3	前面板 USB 2.0 規格接頭
USB4, USB5	背板 USB 3.2 Gen 1x1 規格連接埠 (5 Gb, Type-A)
USB6	背板 Thunderbolt™ 4 (TBT 4) 規格連接埠 (40 Gb, Type-C)
USB7	前面板 USB 3.2 Gen 2x2 規格接頭 (20 Gb, Type-C)
USB8/9	前面板 USB 3.2 Gen 1x1 規格接頭 (5 Gb, Type-A)

線上技術支援及下載

- 聯絡我們 (技術支援信箱) : www.supermicro.com (Email: support@supermicro.com)
- 產品手冊文件 : <https://www.supermicro.com/support/manuals>
- 驅動程式及工具程式 : <https://www.supermicro.com/wdl/driver/>
- 產品安全性須知 : https://www.supermicro.com/about/policies/safety_information.cfm

LED 指示燈

LED 指示燈		
LED	說明	燈號顏色及狀態
BOOT LED	開機硬碟 POST 狀態 * POST (Power-On Self-Test; 開機自我檢測)	橘燈：正在執行硬碟 POST 程序 燈滅：完成硬碟 POST 程序
CPU LED	CPU POST 狀態	黃燈：正在執行 CPU POST 程序 燈滅：完成 CPU POST 程序
DIMM LED	記憶體 POST 狀態	藍燈：正在執行記憶體 POST 程序 燈滅：完成記憶體 POST 程序
LED1	開機及待機 S3 (Suspend to RAM) 模式指示燈	綠燈恆亮：開機狀態 綠燈閃爍：待機 S3 模式
LED17	無線網路 POST 狀態	綠燈：正在執行無線網路 POST 程序 燈滅：完成無線網路 POST 程序
LED18	藍芽 POST 狀態	綠燈：正在執行藍芽 POST 程序 燈滅：完成藍芽 POST 程序
LED3, LED15	分別代表 M.2-P1 / M.2-C1 的 M.2 裝置指示燈	綠燈恆亮：偵測到 M.2 裝置 綠燈閃爍：M.2 裝置使用中
VGA LED	VGA 顯示功能 POST 狀態	綠燈：正在執行 VGA POST 程序 燈滅：完成 VGA POST 程序

中央處理器安裝

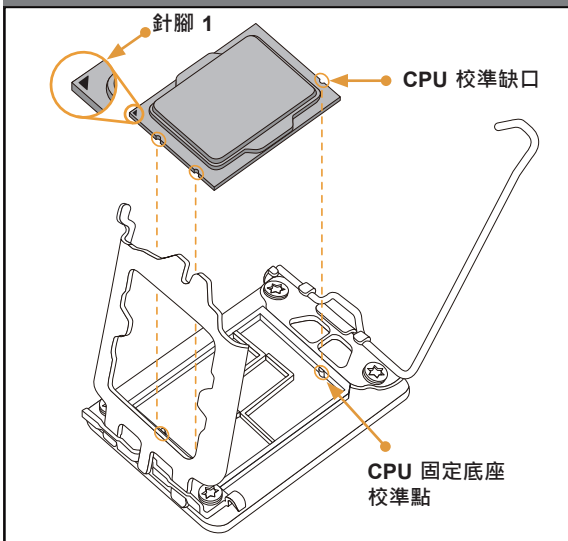

散熱器安裝

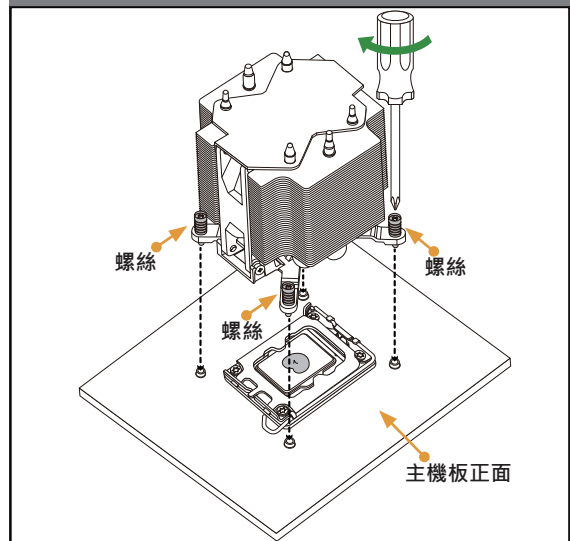

前控制面板配置 (JF1)

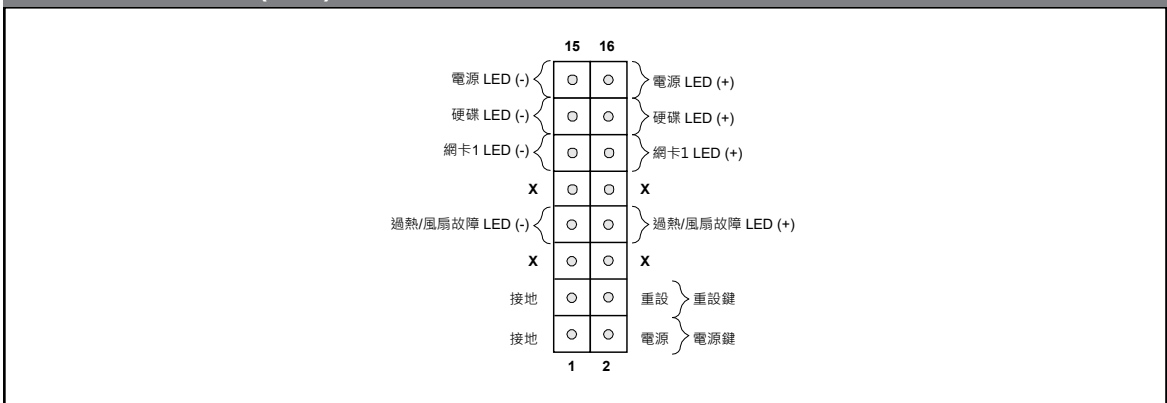

備註

- 快速參考指南中，圖例僅供安裝及操作說明使用，可能與實際產品外觀不同。
- 欲知更多跳線器/連接埠/指示燈/記憶體/主機板/中央處理器安裝相關資訊，請參閱使用手冊。

中央處理器和記憶體支援

主機板 C9Z890-MW/C9B860-MW/C9Q870-M 支援單顆 Intel Core™ Ultra 200S (Ultra 9/7/5) 或 Core Ultra 200S Plus (Ultra 7/5) 系列處理器 (Socket V1, LGA 1851)。記憶體支援 DDR5 256 GB non-ECC Unbuffered DIMM (UDIMM) 和 Clocked Unbuffered DIMM (CUDIMM) 及四根傳輸速度可達 5600 MT/s (1DPC) 288 支針腳記憶體插槽。欲取得雙通道效能，請安裝成對相同型號與速度的記憶體。

Notes: 1) 請安裝本公司認可的記憶體模組以達記憶體模組最佳化。更多記憶體模組相關訊息，請參閱本公司網頁 <https://www.supernmicro.com/products/motherboard>。

- 增加、移除或更換任何硬體元件前，請務必先拔掉電源線。待確實完成所有程序後，再重新連接電源線。
- 請確保保冷卻風扇工作正常，以避免系統過熱損壞處理器和主機板。

記憶體模組 (DIMM) 安裝



此面朝向中央處理器



請依照以下說明及表格安裝記憶體模組：

- 請遵循以下插槽編號順序依序安裝：
DIMMB2 (通道B插槽2)、DIMMA2 (通道A插槽2)、DIMMB1 (通道B插槽1)、DIMMA1 (通道A插槽1)。
- 請使用相同型號與速度的記憶體。
- 若混合使用不同速度的記憶體，系統將依較低記憶體速度執行。
- DDR5 記憶體模組不可熱插拔，在安裝或取出前請務必斷開電源至少二十秒。
- 傾斜拆卸 DDR5 記憶體模組會導致其損壞。請以垂直向上方式將記憶體模組從插槽中取出。

記憶體支援				記憶體插槽配置組態 (Balanced)				
傳輸頻率	4400 MT/s (2DPC)	4800 MT/s (2DPC)	5600 MT/s (1DPC)	DIMMA1	DIMMB1	DIMMA2	DIMMB2	系統記憶體總容量
DIMMA1	2R DIMM	1R DIMM	N/A			8 GB DIMM	8 GB DIMM	16 GB
DIMMA2	2R DIMM	1R DIMM	1R or 2R DIMM	8 GB DIMM	8 GB DIMM	8 GB DIMM	8 GB DIMM	32 GB
DIMMB1	2R DIMM	1R DIMM	N/A			16 GB DIMM	16 GB DIMM	32 GB
DIMMB2	2R DIMM	1R DIMM	1R or 2R DIMM	16 GB DIMM	16 GB DIMM	24 GB DIMM	24 GB DIMM	48 GB
				16 GB DIMM	16 GB DIMM	16 GB DIMM	16 GB DIMM	64 GB
				24 GB DIMM	24 GB DIMM	32 GB DIMM	32 GB DIMM	64 GB
				24 GB DIMM	24 GB DIMM	24 GB DIMM	24 GB DIMM	96 GB
				32 GB DIMM	32 GB DIMM	48 GB DIMM	48 GB DIMM	96 GB
				32 GB DIMM	32 GB DIMM	32 GB DIMM	32 GB DIMM	128 GB
				48 GB DIMM	48 GB DIMM	64 GB DIMM	64 GB DIMM	128 GB
				64 GB DIMM	64 GB DIMM	48 GB DIMM	48 GB DIMM	192 GB
				64 GB DIMM	64 GB DIMM	64 GB DIMM	64 GB DIMM	256 GB

背板輸出/輸入連接埠

1. DisplayPort 2.1 連接埠	9. 無線網路 WiFi 7 和藍芽 Bluetooth 5.4 (已預先安裝，僅限 C9Z890-MW 和 C9B860-MW)
2. HDMI 2.1 高清晰度多媒體介面連接埠	10. 中央/低音聲道輸出
3. USB0, USB1 : USB 2.0 (Type-A) 規格連接埠	11. 環繞聲道輸出
4. LAN1 : RJ45 1 GbE 網路線連接埠	12. S/PDIF 輸出
5. USB4 : USB 3.2 Gen 1x1 規格連接埠 (5 Gb, Type-A)	13. 音效輸入
6. USB5 : USB 3.2 Gen 1x1 規格連接埠 (5 Gb, Type-A)	14. 音效輸出 (備註 1)
7. USB6 : TBT 4 規格連接埠 (40 Gb, Type-C)	15. 麥克風插孔 (備註 1, 備註 2)
8. CMOS 組態資料清除開關	

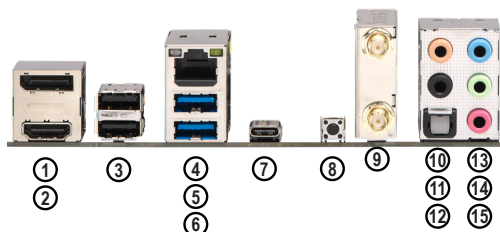

備註 1: 與前面板音效接頭 (AUDIO FP) 連接的耳機/麥克風組合插孔支援單獨的耳機與麥克風裝置。
備註 2: 如果前面板音效接頭 (AUDIO FP) 非連接耳機/麥克風組合插孔，單獨的麥克風裝置僅可在背板的麥克風插孔使用。

包装内容

- Supermicro主板 x1
- SATA线 x4
- S接口 (S-Connector) x1
- I/O扩展板 x1
- 快速参考指南 x1
- 天线 x2 (仅限 C9Z890-MW 和 C9B860-MW)

跳线和接口

跳线		
跳线	描述说明	默认
JPME2	Intel® 制造模式	针脚1-2: 正常
JWD1	看门狗功能启用	针脚1-2: 重置
POWER BUTTON	内部电源按钮	按钮开关
RESET BUTTON	板载系统重置按钮	按钮开关
SW1	后面板清除CMOS按钮	按钮开关

接口	
接口	说明
12V_PUMP_PWR1	12 V 4针电源连接器 (用于 CPU 液体冷却泵)
AUDIO FP	前面板音频插座 * 此插座用于插接耳机/麦克风组合插孔。如果使用独立麦克风, 请使用后面板上的麦克风插孔。 * 后面板上提供独立耳机和麦克风插孔。
B1	板载电池
COM1	COM 端口
DP	后面板 DisplayPort 2.1 (支持最高数据传输率达 10 Gbps)
FAN_1, FAN_A, FAN_1A, FAN_2B, FAN_2-FAN_4,	FAN_1, FAN_A, FAN_1A, FAN_2B: 系统风扇插座 FAN_2-FAN_4: CPU 风扇插座
HD AUDIO	高清音频端口
HDMI	高清音频多媒体接口 2.1 (支持最高数据传输率达 8 Gbps)
I-SATA0-I-SATA3	Intel SATA 3.0 端口 (自 PCH, 6 Gbps, 支持 RAID 0/1/5/10)
JF1	前控制面板插座 * 插入时请将 S 接口 (S-Connector) 上的印刷标示与 JF1 上的相应引脚对齐。
JL1	机箱侵入插座
JLED1	3针电源 LED 指示灯插座
JPW1	24针 ATX 主电源接口 (必需)
JPW2	+12 V 8针 CPU 电源接口 (必需)
JRLED1	5 V 3针可寻址 RGB (ARGB) LED 连接插座 * 仅用于 5 V 3针 ARGB LED 连接。
JSD1	SATA Disk-On-Module (DOM) 电源接口
JSTBY1	5 V 待机电源插座
JTPM1	可信平台模块 (TPM)/端口 80 插座 (仅 TPM 2.0)
LAN1	RJ45 1 GbE LAN端口
M.2-C1	PCIe 5.0 x4 M.2 M-Key 插口 (自 CPU, 支持 2280/22110 规格与 RAID 0/1)
M.2-E1 (PCIe)	WiFi 7 和 Bluetooth 5.4 (已预装, 仅限 C9Z890-MW 和 C9B860-MW)
M.2-P1	PCIe 4.0 x4 M.2 M-Key 插槽 (自 PCH, 支持 2260/2280 规格与 RAID 0/1)
SLOT4	PCIe 4.0 x4 插槽 (自 PCH)
SLOT6	PCIe 5.0 x16 插槽 (自 CPU)
SLOT7	PCIe 4.0 x1 插槽 (自 PCH)
USB0, USB1	后面板 USB 2.0 端口 (Type-A)
USB2/3	前面板 USB 2.0 插座
USB4, USB5	后面板 USB 3.2 Gen 1x1 端口 (5 Gb, Type-A)
USB6	后面板 Thunderbolt™ 4 (TBT 4) 端口 (40 Gb, Type-C)
USB7	前面板 USB 3.2 Gen 2x2 插座 (20 Gb, Type-C)
USB8/9	前面板 USB 3.2 Gen 1x1 插座 (5 Gb, Type-A)

联系信息

- www.supermicro.com (Email: support@supermicro.com)
- 产品手册文件: <https://www.supermicro.com/support/manuals>
- 驱动程序及工具: <https://www.supermicro.com/wdl/driver/>
- 产品安全性须知: https://www.supermicro.com/about/policies/safety_information.cfm

LED指示器

LED指示器		
LED	描述说明	颜色/状态
BOOT LED	可引导设备开机自检 (POST) 状态	橙灯亮: 可引导设备 POST 熄灭: 可引导设备 POST 完成
CPU LED	CPU POST 状态	黄灯亮: CPU POST 熄灭: CPU POST 完成
DIMM LED	DIMM POST 状态	蓝灯亮: DIMM POST 熄灭: DIMM POST 完成
LED1	板载电源 LED S3 (挂起到 RAM) LED	绿灯亮: 开机 闪烁绿灯: S3
LED17	WLAN POST 状态	绿灯亮: WLAN POST 熄灭: WLAN POST 完成
LED18	蓝牙 POST 状态	绿灯亮: 蓝牙设备 POST 熄灭: 蓝牙设备 POST 完成
LED3, LED15	M.2 LED 用于 M.2-P1 / M.2-C1	绿灯亮: 检测到 PCIe 设备 闪烁绿灯: 活动
VGA LED	板载 VGA POST 状态	绿灯亮: 板载 VGA POST 熄灭: 板载 VGA POST 完成

CPU安装

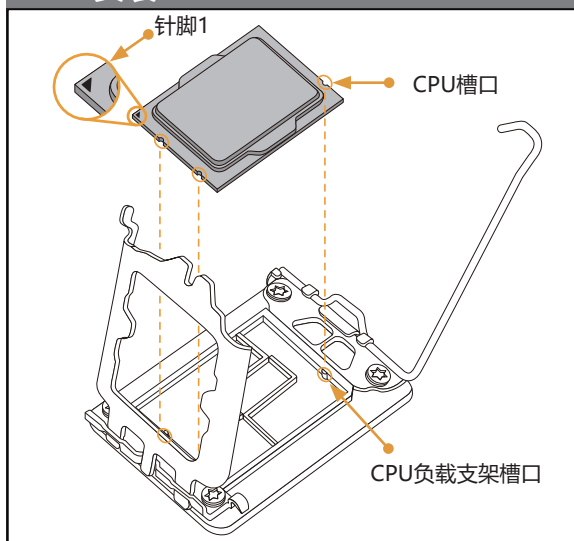

散热器安装

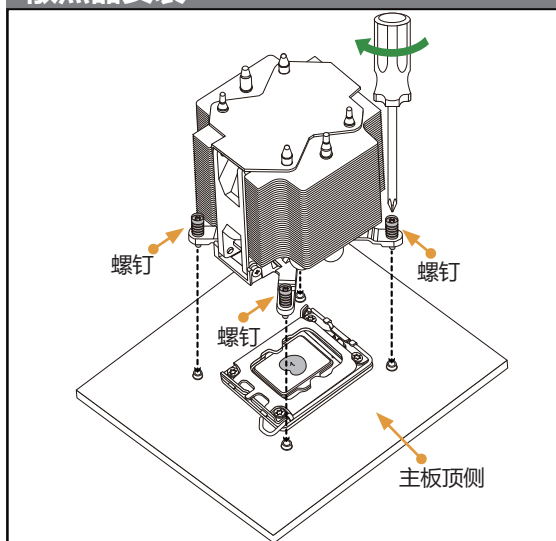

前面控制面板 (JF1)

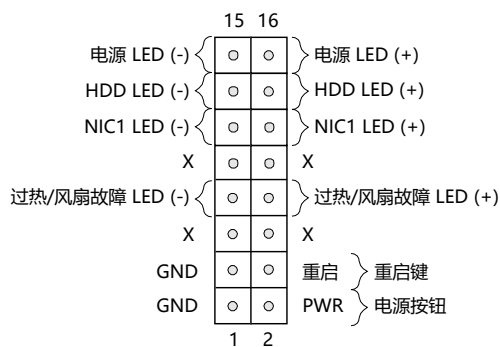

备注

- 此快速参考指南中显示的图片，仅用于图示目的。您的组件可能和或不与此指南中显示的图片完全相同。
- 有关跳线、接口、LED指示灯、内存支持和CPU/主板安装说明的详细信息，请参阅用户手册。

CPU和内存支持

C9Z890-MW/C9B860-MW/C9Q870-M 支持单颗 Intel Core™ Ultra 200S (Ultra 9/7/5) 或 Core Ultra 200S Plus (Ultra 7/5) 系列处理器 (Socket V1, LGA 1851)，在四个 288 针内存插槽中最高支持 DDR5 256 GB non-ECC UDIMM 与 CUDIMM 内存，速度高达 5600 MT/s (1DPC)。为确保获得最佳系统性能，请在配置系统内存时安装相同类型和大小的内存模块；如果安装不同速度的内存模块，它们将以最低安装内存模块速度运行。

-  **备注:** 1) 要进行内存优化，请仅使用经Supermicro验证的DIMM模块。有关最新内存更新，请参阅我们的网站 <https://www.supermicro.com/products/motherboard>。
- 2) 务必最后连接电源线，并在添加、移除或更换任何硬件组件之前断开电源线。
- 3) 过热会严重损坏CPU和主板。始终确保冷却风扇正常工作，以防止CPU过热。

DIMM内存安装

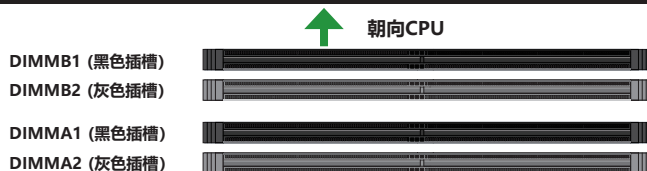

内存安装指南

安装内存模块时，应按照以下顺序插入 DIMM 插槽：DIMMB2、DIMMA2、DIMMB1、DIMMA1。

- 为优化内存性能，请在主板上使用相同类型、大小和速度的 (DDR5) 内存。
- 当安装不同频率 DIMM 内存模组时，所有 DIMM 将以最低 DIMM 的速度运行。
- DDR5 DIMM 模块不可热插拔，插入或取下之前，请确保断开电源至少20秒。
- 倾斜取下 DDR5 DIMM 模块会导致模块损坏。强烈建议直接将模块从插槽中提起。

内存支持				推荐数量 (平衡型)				
频率	4400 MT/s (2DPC)	4800 MT/s (2DPC)	5600 MT/s (1DPC)	DIMMA1	DIMMB1	DIMMA2	DIMMB2	总系统内存
DIMMA1	2R DIMM	1R DIMM	N/A	8 GB DIMM	8 GB DIMM	8 GB DIMM	8 GB DIMM	16 GB
DIMMA2	2R DIMM	1R DIMM	1R 或 2R DIMM			8 GB DIMM	8 GB DIMM	32 GB
DIMMB1	2R DIMM	1R DIMM	N/A			16 GB DIMM	16 GB DIMM	32 GB
DIMMB2	2R DIMM	1R DIMM	1R 或 2R DIMM			24 GB DIMM	24 GB DIMM	48 GB
				16 GB DIMM	16 GB DIMM	16 GB DIMM	16 GB DIMM	64 GB
						32 GB DIMM	32 GB DIMM	64 GB
				24 GB DIMM	24 GB DIMM	24 GB DIMM	24 GB DIMM	96 GB
						48 GB DIMM	48 GB DIMM	96 GB
				32 GB DIMM	32 GB DIMM	32 GB DIMM	32 GB DIMM	128 GB
						64 GB DIMM	64 GB DIMM	128 GB
				48 GB DIMM	48 GB DIMM	48 GB DIMM	48 GB DIMM	192 GB
				64 GB DIMM	64 GB DIMM	64 GB DIMM	64 GB DIMM	256 GB

I/O后面板接口

1. DisplayPort 2.1	9. WiFi 7 + Bluetooth 5.4 (已预装, 仅限 C9Z890-MW 和 C9B860-MW)
2. HDMI 2.1	10. 中心/LFE输出
3. USB0, USB1: USB 2.0 (Type-A)	11. 环绕输出
4. LAN1: RJ45 1 GbE LAN 端口	12. S/PDIF输出
5. USB4: USB 3.2 Gen 1x1 (5 Gb, Type-A)	13. 线路输入
6. USB5: USB 3.2 Gen 1x1 (5 Gb, Type-A)	14. 线路输出 (注 1)
7. USB6: TBT 4 (40 Gb, Type-C)	15. 麦克风输入 (注 1, 注 2)
8. 清除 CMOS 按钮	

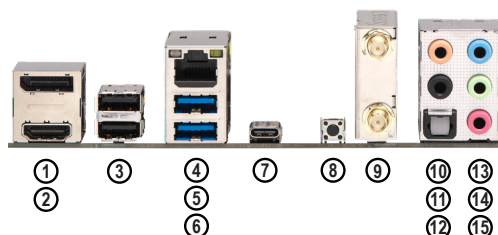

注 1: 连接到前面音频插座 (AUDIO FP) 的耳机/麦克风组合插孔支持独立耳机和麦克风。
注 2: 如果前面音频插座 (AUDIO FP) 没有连接耳机/麦克风组合插孔，请使用后面板上的麦克风插孔插接独立麦克风。

MNL-2707-QRG-10C

© 2026 美超微股份有限公司 (以下简称「本公司」) 版权所有。未经验本公司书面同意，严禁复制或转载任何内容。所有商标均为所属公司所有。所有提供资讯均印刷之概视为但不保证正确。

マザーボードのレイアウトと機能

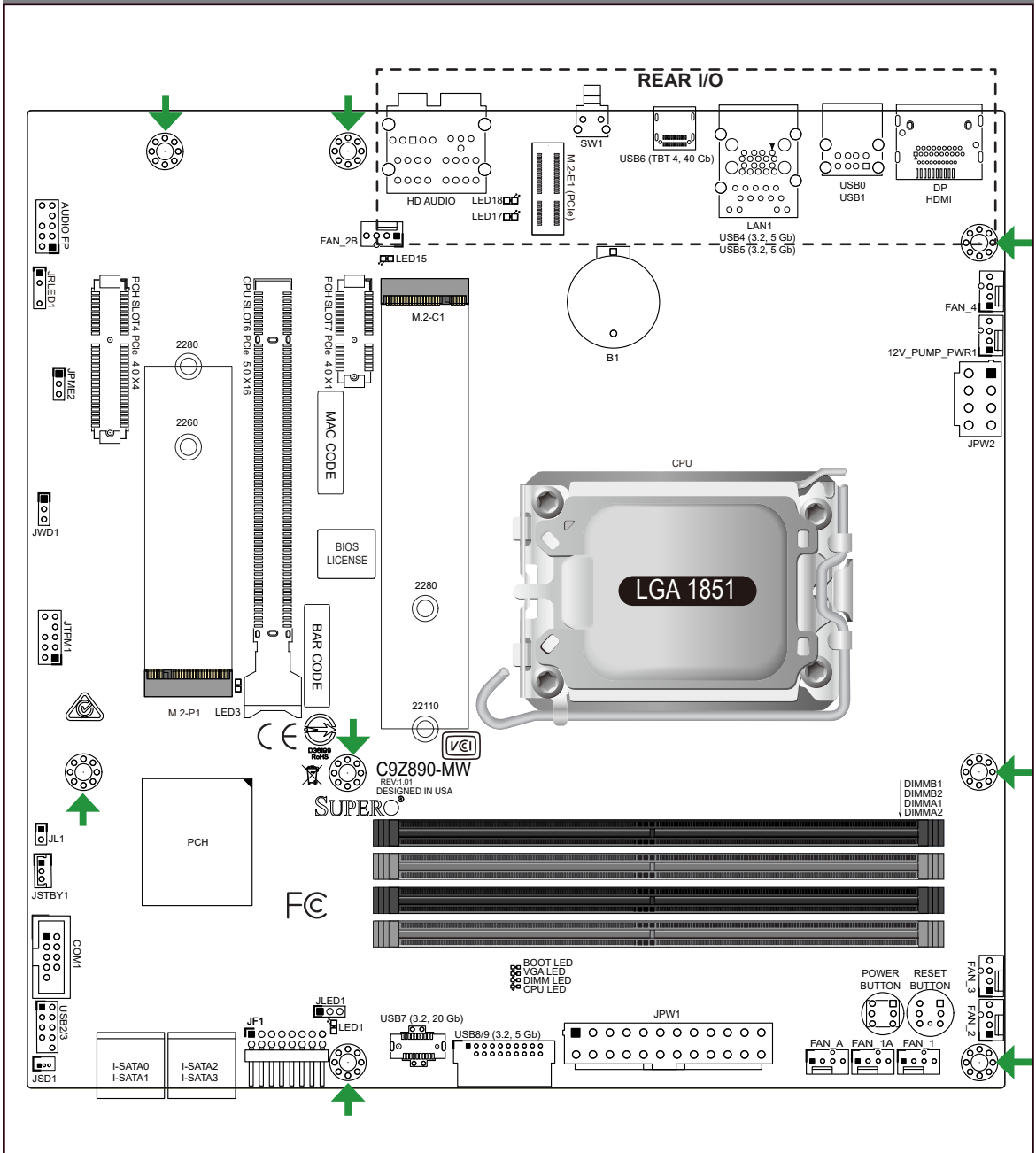

Differences between C9Z890-MW, C9B860-MW, and C9Q870-M			
	C9Z890-MW	C9B860-MW	C9Q870-M
WiFi 7 + Bluetooth 5.4 Module	Yes	Yes	N/A
PCH Chipset	Intel Z890	Intel B860	Intel Q870
LAN Controller	Intel Ethernet i219-V	Intel Ethernet i219-V	Intel Ethernet i219-LM
Overclocking Support	Yes (CPU and Memory)	Yes (Memory)	N/A

➡ = 取付穴

パッケージ内容

- Supermicro マザーボード 1枚
- I/O シールド 1個
- SATA ケーブル 4本
- クイック参照ガイド 1冊
- S-コネクタ 1個
- アンテナ 2本 (C9Z890-MW および C9B860-MWのみ)

ジャンパーおよびコネクタ

ジャンパー		
ジャンパー	説明	デフォルト
JPME2	Intel® マニファクチャーマード	ピン 1-2 : ノーマル
JWD1	ウォッチドッグ機能の有効化	ピン 1-2 : リセット
電源ボタン	内部電源ボタン	ボタンスイッチ
リセットボタン	オンボードシステムリセットボタン	ボタンスイッチ
SW1	背面 CMOS クリアボタン	ボタンスイッチ

コネクタ	
コネクタ	説明
12V_PUMP_PWR1	12 V 4 ピン電源コネクタ (CPU 水冷ポンプ用)
オーディオ FP	前面 オーディオヘッダー * このヘッダーはヘッドフォン/マイク コンボジャック向けに設計されています。独立したマイクを使用する場合は、リアパネルの マイク ジャックを使用してください。 * 独立したヘッドフォン用ジャックおよびマイク用ジャックは、リアパネルにあります。
B1	オンボードバッテリー
COM1	COM ヘッダー
DP	背面 DisplayPort 2.1 (最大 10 Gbps)
FAN_1, FAN_A, FAN_1A, FAN_2B, FAN_2-FAN_4	FAN_1, FAN_A, FAN_1A, FAN_2B : システムファンヘッダー FAN_2-FAN_4 : CPU ファンヘッダー
HD オーディオ	ハイデフィニション オーディオポート
HDMI	HDMI 2.1 (最大 8 Gbps)
I-SATA0-I-SATA3	Intel SATA 3.0 ポート (PCH から、6 Gbps、RAID 0/1/5/10 をサポート)
JF1	フロントコントロールパネルヘッダー * Sコネクタに印刷されている印とJF1の対応するピンの位置を合わせてつなげてください。
JF1	シャーシイントルージョンヘッダー
JLED1	3 ピン電源 LED インジケータヘッダー
JPW1	24 ピン ATX 主電源コネクタ (必須)
JPW2	+12 V 8 ピン CPU 電源コネクタ (必須)
JRLED1	5 V 3 ピン アドレス可能 RGB (ARGB) LED 接続ヘッダー * 2つのヘッダーは 5 V 3 ピン ARGB LED 接続専用です。
JSD1	SATA Disk-On-Module (DOM) 電源コネクタ
JSTBY1	5 V スタンバイ電源ヘッダー
JTPM1	Trusted Platform Module (TPM)/ポート 80 ヘッダー (TPM 2.0 のみ)
LAN1	RJ45 1 GbE LAN ポート
M.2-C1	PCIe 5.0 x4 M.2 M-キースロット (CPU 経由、2280/22110 フォームファクタ対応、RAID 0/1 サポート)
M.2-E1 (PCIe)	WiFi 7 および Bluetooth 5.4 (インストール済み、C9Z890-MW および C9Z890-MW のみ)
M.2-P1	PCIe 4.0 x4 M.2 M-キースロット (PCH 経由、2260/2280 フォームファクタ対応、RAID 0/1 サポート)
SLOT4	PCIe 4.0 x4 スロット (PCH から)
SLOT6	PCIe 5.0 x16 スロット (CPU から)
SLOT7	PCIe 4.0 x1 スロット (PCH から)
USB0, USB1	リア USB 2.0 ポート (タイプ A)
USB2/3	フロントアクセス USB 2.0 ヘッダー
USB4, USB5	リア USB 3.2 Gen 1x1 ポート (5 Gb、タイプ A)
USB6	リア Thunderbolt™ 4 (TBT 4) ポート (40 Gb、タイプ C)
USB7	フロントアクセス USB 3.2 Gen 2x2 ヘッダー (20 Gb、タイプ C)
USB8/9	フロントアクセス USB 3.2 Gen 1x1 ヘッダー (5 Gb、タイプ A)

お問い合わせ先

- www.supermicro.com (Eメール : support@supermicro.com)
- マニュアル : <https://www.supermicro.com/support/manuals>
- ドライバー & ユーティリティ : <https://www.supermicro.com/wdl/driver/>
- 安全性 : https://www.supermicro.com/about/policies/safety_information.cfm

LED インジケーター

LED インジケーター

LED	説明	カラー/状態
ブート LED	ブータブルデバイスのパワーオン・セルフテスト (POST) ステータス	オレンジ色点灯 : ブート可能デバイス POST オフ : ブート可能デバイス POST 完了
CPU LED	CPU POSTステータス	黄色点灯 : CPU POST オフ : CPU POST 完了
DIMM LED	DIMM POSTステータス	青色点灯 : DIMM POST オフ : DIMM POST 完了
LED1	オンボード電源 LED S3 (RAMにサスペンド) LED	緑色点灯 : 電源オン 緑色点滅 : S3
LED17	WLAN POSTステータス	緑色点灯 : WLAN POST オフ : WLAN POST 完了
LED18	Bluetooth デバイスのPOSTステータス	緑色点灯 : Bluetooth デバイス POST オフ : Bluetooth デバイス POST 完了
LED3、LED15	M.2-P1/M.2-C1 用 M.2 LED	緑色点灯 : PCIe デバイス検知済み 緑色点滅 : アクティビティ
VGA LED	オンボード VGA POSTステータス	緑色点灯 : オンボード VGA POST オフ : オンボード VGA POST 完了

CPUの設置

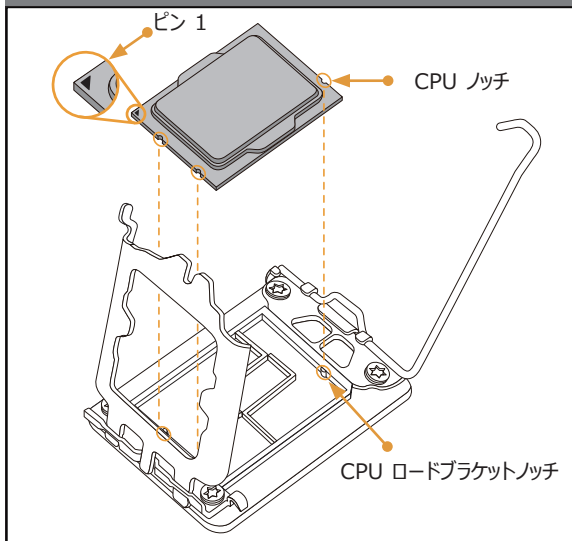

ヒートシンクの設置

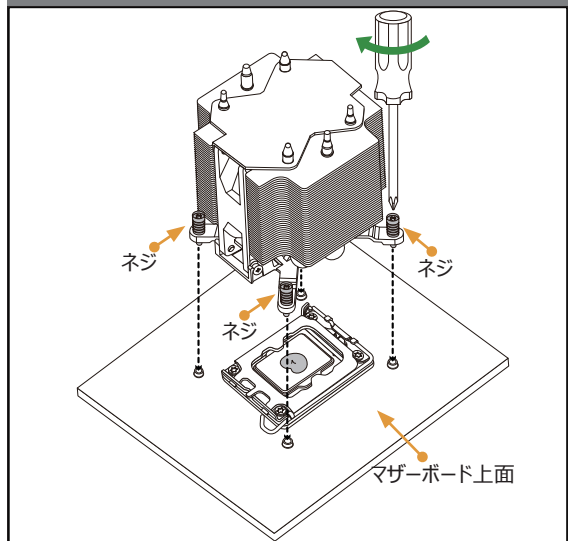

フロントコントロールパネル (JF1)

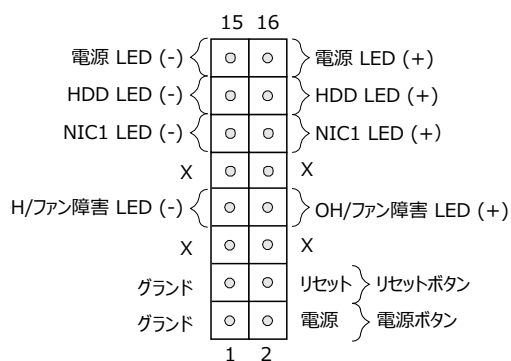

注記

- 本クイック参照ガイドにある図は参考用です。お手元のコンポーネントは、本ガイドに示されている図と異なるか、まったく同一ではない可能性があります。
- ジャンパ、コネクタ、LED インジケータ、対応メモリ、および CPU /マザーボードの設置方法に関する詳細については、ユーザーマニュアルを参照してください。

CPU およびメモリサポート

C9Z890-MW/C9B860-MW/C9Q870-MIは Intel Core™ Ultra 200S (Ultra 9/7/5) プロセッサもしくは Intel Core Ultra 200S Plus (Ultra 7/5) プロセッサ (ソケット V1, LGA 1851) を 1 個搭載可能。DDR5 non-ECC メモリに対応した 4 つの 288 ピンメモリスロットを備え、最大 256 GB の UDIMM および CUDIMM メモリをサポートし、最大 5600 MT/秒 (1DPC) に対応しています。これらの DIMM スロットにタイプとサイズが同じメモリモジュールのペアを装着した場合、インターリーブメモリが生成されて、メモリパフォーマンスが向上します。

- 注記：1) メモリの最適化には、Supermicro によって検証済みの DIMM モジュールのみを使用してください。最新のメモリ情報については、当社のウェブサイト (<https://www.supermicro.com/products/motherboard>) を参照してください。
- 2) 電源コードは必ず最後につなげてください。また、ハードウェアコンポーネントを追加、取り外し、または変更する前には必ずその前に抜いてください。
- 3) オーバーヒートが発生すると、CPU とマザーボードに深刻な損傷を与える可能性があります。CPU をオーバーヒートから保護するため、冷却ファンが適切に機能していることを常に確認してください。

DIMM メモリ設置



メモリモジュール取付ガイドライン

メモリモジュールを取り付けるときは、以下の順序で DIMM スロットに挿入してください。DIMMB2、DIMMA2、DIMMB1、DIMMA1。

- メモリパフォーマンスを最適化するには、マザーボードで同じタイプ、サイズ、速度の (DDR5) メモリを使用してください。
- 異なる速度の DIMM を増設できます。しかしながら、すべての DIMM が最も遅い速度の DIMM の速度で動作します。
- DDR5 DIMM モジュールはホットスワップ対応ではないため、抜き差しする前に必ず 20 秒以上にわたって電源を切断するようにしてください。
- DDR5 DIMM モジュールを斜めに取り外すと、モジュールが破損します。モジュールをスロットからまっすぐ上に持ち上げることを強くお勧めします。

推奨スロット位置 (バランス)

メモリサポート			
周波数	4400 MT/秒 (2DPC)	4800 MT/秒 (2DPC)	5600 MT/秒 (1DPC)
DIMMA1	2R DIMM	1R DIMM	該当なし
DIMMA2	2R DIMM	1R DIMM	1R または 2R DIMM
DIMMB1	2R DIMM	1R DIMM	該当なし
DIMMB2	2R DIMM	1R DIMM	1R または 2R DIMM

DIMMA1	DIMMB1	DIMMA2	DIMMB2	総システムメモリ
		8 GB DIMM	8 GB DIMM	16 GB
8 GB DIMM	8 GB DIMM	8 GB DIMM	8 GB DIMM	32 GB
		16 GB DIMM	16 GB DIMM	32 GB
		24 GB DIMM	24 GB DIMM	48 GB
16 GB DIMM	16 GB DIMM	16 GB DIMM	16 GB DIMM	64 GB
		32 GB DIMM	32 GB DIMM	64 GB
24 GB DIMM	24 GB DIMM	24 GB DIMM	24 GB DIMM	96 GB
		48 GB DIMM	48 GB DIMM	96 GB
32 GB DIMM	32 GB DIMM	32 GB DIMM	32 GB DIMM	128 GB
		64 GB DIMM	64 GB DIMM	128 GB
48 GB DIMM	48 GB DIMM	48 GB DIMM	48 GB DIMM	192 GB
64 GB DIMM	64 GB DIMM	64 GB DIMM	64 GB DIMM	256 GB

背面 I/O コネクタ

1. DisplayPort 2.1	9. WiFi 7 + Bluetooth 5.4 (インストール済み、C9Z890-MW および C9B860-MW のみ)
2. HDMI 2.1	10. センター/ LFE 出力
3. USB0、USB1 : USB 2.0 (タイプ A)	11. サラウンド出力
4. LAN1 : RJ45 1 GbE LAN ポート	12. S/PDIF 出力
5. USB4 : USB 3.2 Gen 1x1 (5 Gb、タイプ A)	13. ライン入力
6. USB5 : USB 3.2 Gen 1x1 (5 Gb、タイプ A)	14. ライン出力 (注 1)
7. USB6 : TBT 4 (40 Gb、タイプ C)	15. マイク入力 (注 1、注 2)
8. CMOS クリアボタン	

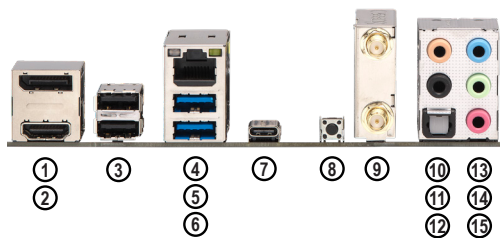

注 1: フロント オーディオヘッダー (オーディオ FP) に接続されたヘッドフォン/マイク コンボジャックは、独立したヘッドフォンおよびマイクをサポートします。

注 2: フロント オーディオヘッダー (オーディオ FP) にヘッドフォン/マイク コンボジャックを接続しない場合は、リアパネルの マイク ジャックを独立したマイクに使用してください。

메인보드 레이아웃 및 특징

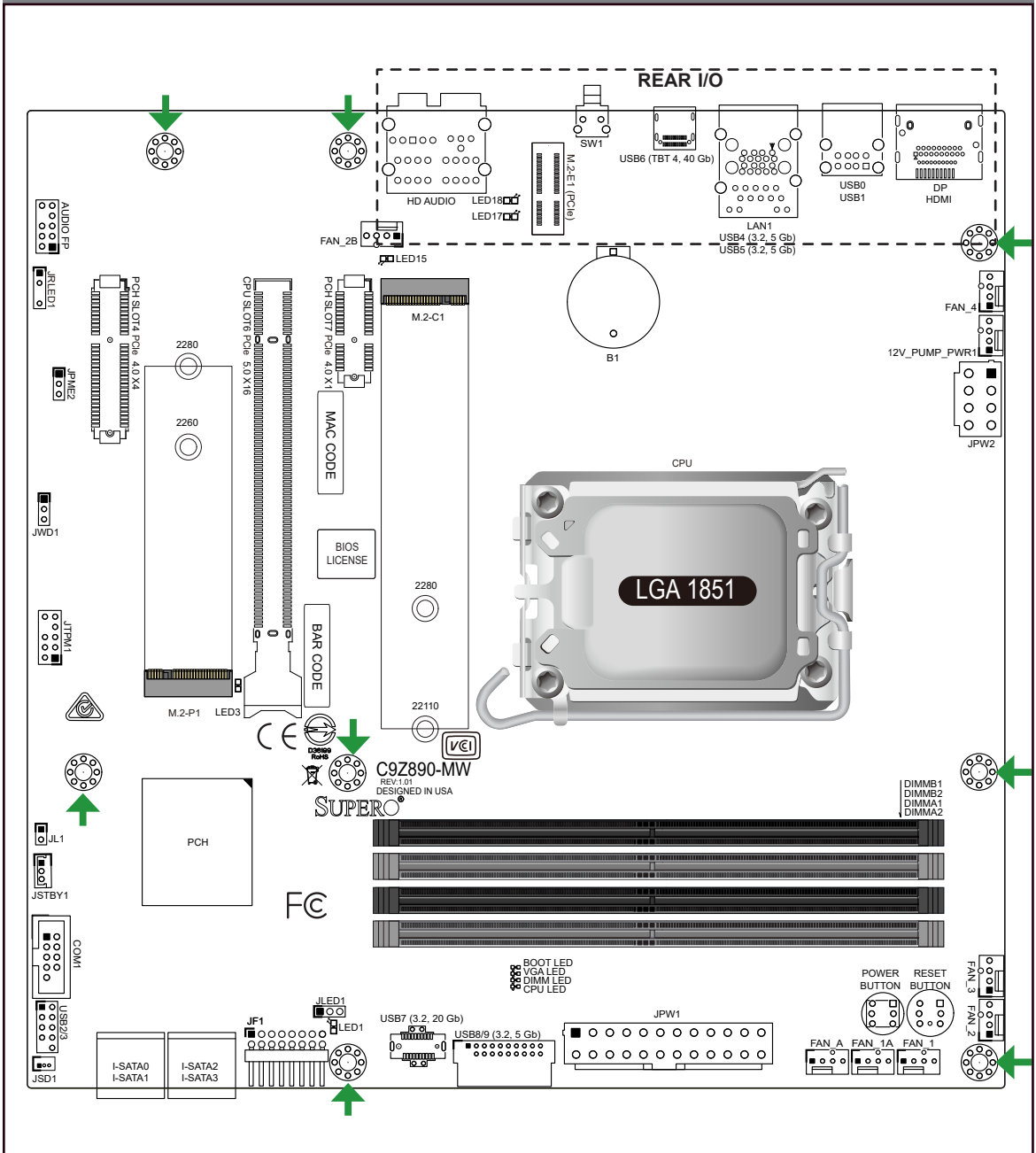

Differences between C9Z890-MW, C9B860-MW, and C9Q870-M			
	C9Z890-MW	C9B860-MW	C9Q870-M
WiFi 7 + Bluetooth 5.4 Module	Yes	Yes	N/A
PCH Chipset	Intel Z890	Intel B860	Intel Q870
LAN Controller	Intel Ethernet i219-V	Intel Ethernet i219-V	Intel Ethernet i219-LM
Overclocking Support	Yes (CPU and Memory)	Yes (Memory)	N/A

➔ = 나사 구멍

제품 구성물

- Supermicro 메인보드 1개
- SATA 케이블 4개
- S-커넥터 1개
- I/O 쉴드 1개
- 간편 가이드 1부
- 안테나 2개 (C9Z890-MW 및 C9B860-MW)

점퍼 및 커넥터

점퍼

점퍼	설명	기본값
JPME2	Intel® 제조 모드	핀 1-2: 정상
JWD1	Watchdog 기능 활성화	핀 1-2: 리셋
전원 버튼	내부 전원 버튼	Push 버튼 스위치
초기화 버튼	시스템 초기화 버튼	Push 버튼 스위치
SW1	후면 CMOS 초기화 버튼	Push 버튼 스위치

커넥터

커넥터	설명
12V_PUMP_PWR1	12 V 4핀 전원 커넥터 (CPU 수냉식 펌프용)
AUDIO FP	전면 오디오 헤더 * 이 헤더는 헤드폰/마이크 콤보 잭용으로 만들어졌습니다. 표준 마이크를 사용하는 경우에는 후면 패널의 마이크 잭을 사용하십시오. * 표준 헤드폰 및 마이크 잭은 후면 패널에 제공됩니다.
B1	온보드 배터리
COM1	COM 헤더
DP	후면 DisplayPort 2.1 (최대 전송속도 10 Gbps 지원)
FAN_1, FAN_A, FAN_1A, FAN_2B, FAN_2-FAN_4	FAN_1, FAN_A, FAN_1A, FAN_2B: 시스템 팬 헤더 FAN_2-FAN_4: CPU 팬 헤더
HD 오디오	HD 오디오 포트
HDMI	고해상도 멀티미디어 인터페이스 2.1 (최대 전송속도 8 Gbps 지원)
I-SATA0-I-SATA3	Intel SATA 3.0 포트 (PCH, 6 Gbps, RAID 0/1/5/10 지원)
JF1	전면 제어판 헤더 * 꽃을 때는 S-커넥터에 인쇄된 표시와 JF1의 해당 핀을 맞추십시오.
JL1	새시 인트루전 헤더
JLED1	3핀 전원 LED 표시등 헤더
JPW1	24핀 ATX 주전원 커넥터 (필수)
JPW2	+12 V 8핀 CPU 전원 커넥터 (필수)
JRLED1	5 V 3핀 주소 지정이 가능한 RGB (ARGB) LED 연결 헤더 * 5 V 3핀 ARGB LED 연결 전용입니다.
JSD1	SATA 디스크-온-모듈 (DOM) 전원 커넥터
JSTBY1	5 V 대기 전원 헤더
JTPM1	TPM/포트 80 헤더 (TPM 2.0만 지원)
LAN1	RJ45 1 GbE LAN 포트
M.2-C1	PCIe 5.0 x4 M.2 M-Key Slot (CPU, 2280/22110 폼팩터 및 RAID 0/1 지원)
M.2-E1(PCIe)	WiFi 7 및 Bluetooth 5.4 (사전 설치됨, C9Z890-MW 및 C9B860-MW에만 해당)
M.2-P1	PCIe 4.0 x4 M.2 M-Key Slot (PCH, 2260/2280 폼팩터 및 RAID 0/1 지원)
SLOT4	PCIe 4.0 x4 슬롯 (PCH)
SLOT6	PCIe 5.0 x16 슬롯 (CPU)
SLOT7	PCIe 4.0 x1 슬롯 (PCH)
USB0, USB1	후면 USB 2.0 포트 (타입 A)
USB2/3	전면 액세스 가능 USB 2.0 헤더
USB4, USB5	후면 USB 3.2 Gen 1x1 포트 (5 Gb, 타입 A)
USB6	후면 Thunderbolt™ 4 (TBT 4) 포트 (40 Gb, 타입 C)
USB7	전면 액세스 가능 USB 3.2 Gen 2x2 헤더 (20 Gb, 타입 C)
USB8/9	전면 액세스 가능 USB 3.2 Gen 1x1 헤더 (5 Gb, 타입 A)

연락처 정보

- www.supermicro.com (이메일: support@supermicro.com)
- 사용 설명서: <https://www.supermicro.com/support/manuals>
- 드라이버 및 유틸리티: <https://www.supermicro.com/wdl/driver/>
- 안전: https://www.supermicro.com/about/policies/safety_information.cfm

LED 표시등

LED 표시등

LED	설명	색/상태
BOOT LED	부팅 가능한 전원 Self 테스트 (POST) 상태	주황색 켜짐: 부팅 가능한 장치 POST OFF: 부팅 가능한 장치 POST 완료
CPU LED	CPU Power-On Self-Test (POST) 상태	노란색 ON: CPU POST OFF: CPU POST 완료
DIMM LED	DIMM Power-On Self-Test (POST) 상태	파란색 ON: DIMM POST OFF: DIMM POST 완료
LED1	온보드 전원 LED S3 (RAM 절전 대기) LED	녹색 켜짐: 전원 켜짐 녹색으로 깜박거림: S3
LED17	WLAN Power-On Self-Test (POST) 상태	녹색 켜짐: WLAN POST OFF: WLAN POST 완료
LED18	Bluetooth 장치 Power-On Self-Test (POST) 상태	녹색 켜짐: Bluetooth 장치 POST OFF: Bluetooth 장치 POST 완료
LED3, LED15	M.2-P1/M.2-C1용 M.2 LED	녹색 켜짐: PCIe 장치가 감지됨 녹색으로 깜박거림: 활동
VGA LED	온보드 VGA Power-On Self-Test (POST) 상태	녹색 켜짐: 온보드 VGA POST OFF: 온보드 VGA POST 완료

CPU 설치

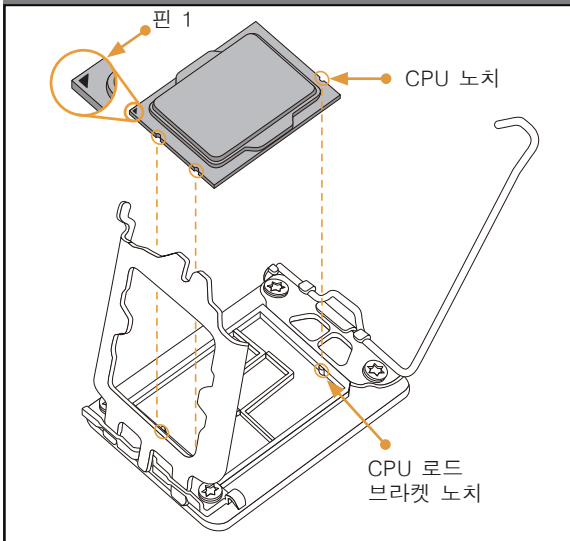

방열판 설치

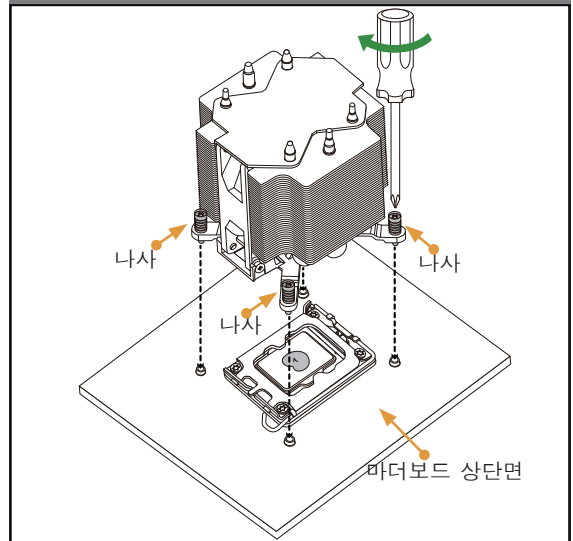

전면 제어 패널 (JF1)

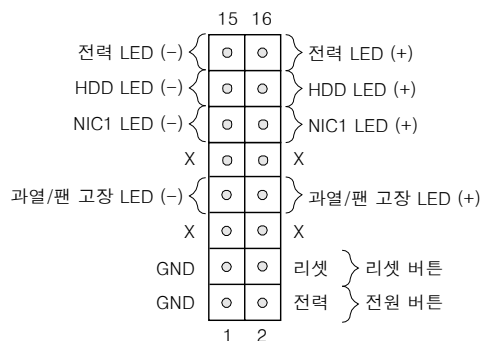

참고

- 이 간편 설명서의 그림들은 예시로만 사용됩니다. 실제 부품은 안내서에 표시된 도면과 동일하지 않을 수 있습니다.
- 접퍼, 커넥터, LED 표시등, 메모리 지원 및 CPU/메인보드 설치 지침에 대한 자세한 내용은 사용 설명서를 참조하십시오.

CPU 및 메모리 지원

C9Z890-MW/C9B860-MW/C9Q870-M 메인보드는 단일 Intel Core™ Ultra 200S (Ultra 9/7/5) 또는 Core Ultra 200S Plus (Ultra 7/5) 프로세서 (LGA 1851, 소켓 V1)를 지원하며, 최대 256 GB 용량의 DDR5 non-ECC 언버퍼드 DIMM (UDIMM) 및 Clocked 언버퍼드 DIMM (CUDIMM)을 지원합니다. 총 4개의 288핀 메모리 슬롯을 통해 구성할 수 있으며, 1DPC 구성 시 최대 5600 MT/s의 속도를 지원합니다. 동일한 종류와 용량의 메모리 모듈을 한 쌍을 이 DIMM 슬롯에 장착하면 메모리 성능을 향상시키는 인터리브드 (Interleaved) 메모리 구성이 됩니다.

- 주: 1) 메모리 최적화를 위해 반드시 Supermicro의 인증을 받은 DIMM 모듈을 사용해야 합니다. 최신 메모리 업데이트는, 저희 웹사이트 <https://www.supermicro.com/products/motherboard>를 참조하세요.
- 2) 전원 코드는 반드시 마지막에 연결하고 하드웨어 구성품을 추가, 제거 또는 변경하기 전에는 반드시 전원을 뽑아야 합니다.
- 3) 과열은 CPU 및 메인보드에 심각한 손상을 줄 수 있습니다. 항상 냉각 팬 기능이 CPU를 과열로부터 보호하는지 확인하십시오.

DIMM 메모리 설치

CPU 방향



메모리 설치 가이드라인

메모리 모듈을 설치할 때 DIMM 슬롯 삽입시 다음 순서를 따라야 합니다. DIMMB2, DIMMA2, DIMMB1, DIMMA1.

- 메모리 성능을 최적화하려면 마더보드에 동일한 유형 크기 및 속도의 메모리 (DDR5) 를 사용합니다.
- 혼합된 DIMM 속도를 설치해도 됩니다. 그러나 모든 DIMM은 가장 느린 DIMM의 속도로 실행됩니다.
- DDR5 DIMM 모듈은 핫스왑이 불가하며, 모듈을 삽입 또는 제거하기 전에 20초 이상 전원의 연결을 끊어야 합니다.
- DDR5 DIMM 모듈을 비스듬한 각도로 분리하면 모듈에 손상이 발생합니다. 모듈을 슬롯에서 위 방향으로 똑바로 들어올리는 것이 좋습니다.

DIMM 슬롯 삽입 권장 (균형)

DIMMA1	DIMMB1	DIMMA2	DIMMB2	총 시스템 메모리
8 GB DIMM	8 GB DIMM	8 GB DIMM	8 GB DIMM	16 GB
		16 GB DIMM	16 GB DIMM	32 GB
		24 GB DIMM	24 GB DIMM	48 GB
16 GB DIMM	16 GB DIMM	16 GB DIMM	16 GB DIMM	64 GB
		32 GB DIMM	32 GB DIMM	64 GB
24 GB DIMM	24 GB DIMM	24 GB DIMM	24 GB DIMM	96 GB
		48 GB DIMM	48 GB DIMM	96 GB
32 GB DIMM	32 GB DIMM	32 GB DIMM	32 GB DIMM	128 GB
		64 GB DIMM	64 GB DIMM	128 GB
48 GB DIMM	48 GB DIMM	48 GB DIMM	48 GB DIMM	192 GB
64 GB DIMM	64 GB DIMM	64 GB DIMM	64 GB DIMM	256 GB

메모리 지원

주파수	4400 MT/s (2DPC)	4800 MT/s (2DPC)	5600 MT/s (1DPC)
DIMMA1	2R DIMM	1R DIMM	해당사항 없음
DIMMA2	2R DIMM	1R DIMM	1R 또는 2R DIMM
DIMMB1	2R DIMM	1R DIMM	해당사항 없음
DIMMB2	2R DIMM	1R DIMM	1R 또는 2R DIMM

후면 I/O 커넥터

1. DisplayPort 2.1	9. WiFi 7 + Bluetooth 5.4 (사전 설치됨, C9Z890-MW 및 C9B860-MW만)
2. HDMI 2.1	10. 중앙/LFE 출력
3. USB0, USB1: USB 2.0 (타입 A)	11. 서라운드 출력
4. LAN1: RJ45 1GbE LAN 포트	12. S/PDIF 출력
5. USB4: USB 3.2 Gen 1x1 (5 Gb, 타입 A)	13. 라인 입력
6. USB5: USB 3.2 Gen 1x1 (5 Gb, 타입 A)	14. 라인 출력 (참고 1)
7. USB6: TBT 4 (40 Gb, 타입 C)	15. 마이크 입력 (참고 1, 참고 2)
8. CMOS 지우기 버튼	

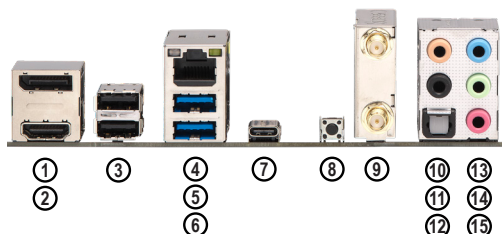

참고 1: 전면 오디오 헤더 (AUDIO FP)에 연결된 헤드폰/마이크 콤보 잭은 표준 헤드폰 및 마이크를 지원합니다.

참고 2: 전면 오디오 헤더 (AUDIO FP)에 연결된 헤드폰/마이크 콤보 잭이 없는 경우에는 표준 마이크용으로 후면 패널의 마이크 잭을 사용하십시오.

MNL-2707-QRG-10C

© 2026 Supermicro Computer Inc. All rights reserved. Reproduction of this document whether in part or in whole is strictly prohibited without Supermicro's written consent. All Trademarks are property of their respective entities. All information provided is deemed accurate at the time of printing; however, it is not guaranteed.

Notes

Notes

Notes



SUPER  TM

Server Quality, Built for Gaming

QUICK REFERENCE GUIDE

Revision 1.0c