

SUPERMICR[®] SuperBlade SBI-4119MG-X Blade Module Quick Reference Guide

Board Layout

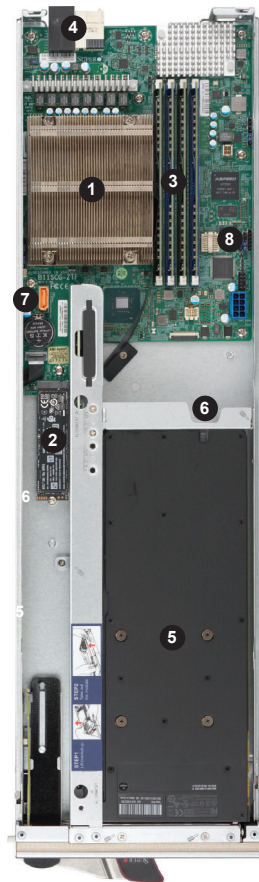

SBI-4119MG-X Module Layout	
Item	Description
1	CPU installed
2	M.2 NVMe storage module
3	DIMM slots (four)
4	Power and Logic connectors to backplane
5	GPU
6	PCI-E Module (Under GPU)
7	SATA Port
8	9-pin TPM Connector

Caution

SAFETY INFORMATION
 IMPORTANT: See installation instructions and safety warning before connecting system to power supply.
http://www.supermicro.com/about/policies/safety_information.cfm

WARNING:
 To reduce risk of electric shock/damage to equipment, disconnect power from server by disconnecting all power cords from electrical outlets. If any CPU socket empty, install protective plastic CPU cap

WARNING:
 Always be sure all power supplies for this system have the same power output. If mixed power supplies are installed, the system will not operate.

For more information go to: <http://www.supermicro.com/support>

Memory Support

The B115CG-CTF motherboard supports up to 128 GB ECC UDIMM DDR4 2666/2400/2133 MHz speed in four memory slots. Populating these DIMM slots with memory modules of the same type and size will result in interleaved memory, which will improve memory performance. Check the Supermicro website for possible updates to memory support.

Memory Population (Balanced)				
DIMMA1	DIMMB1	DIMMA2	DIMMB2	Total System Memory
4GB	4GB			8GB
4GB	4GB	4GB	4GB	16GB
8GB	8GB	8GB	8GB	32GB
16GB	16GB	16GB	16GB	64GB
32GB	32GB	32GB	32GB	128GB

Memory Population Sequence

Blue slots versus black slots: Install the first DIMM in the blue memory slot, which is the first of a memory channel. Then, if using two DIMMs per channel, install the second DIMM in the black slot.

– When installing memory modules, the DIMM slots should be populated in the following order: DIMMB2, DIMMA2, DIMMB1, DIMMA1.

– Always use DDR4 DIMM modules of the same type, size and speed.

– Mixed DIMM speeds can be installed. However, all DIMMs will run at the speed of the slowest DIMM.

The motherboard will support odd-numbered modules (1 or 3 modules installed). However, for best memory performance, install DIMM modules in pairs to activate memory interleaving.

The following memory population diagram is for illustrative purposes; your motherboard may look different.

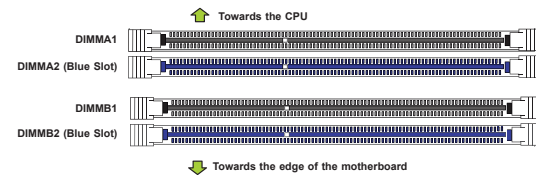

Control Panel

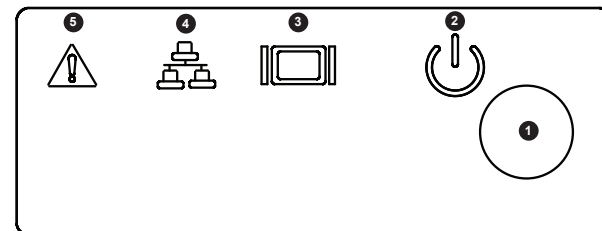

Blade Control Panel			
Item	Function	State	Description
1	Power Button	N/A	Turns blade module on and off
2	Power LED	Green	Indicates power status "On"
		Solid Orange	Indicates power status "Off" (with power cables plugged in)
3	KVM/UID LED	Flashing Orange	Flashing Orange: Indicates node is not ready or not enough power to turn on
		Blue	Indicates KVM being utilized on blade unit
4	Network/IB LED	Flashing Blue	Indicates UID activated on blade module
		Flashing Green	Indicates network activity over LAN
5	System Fault LED	Flashing Orange	Indicates network activity
		Red	Indicates a memory error, overheat, VGA error or any error that prevents booting

Enclosure Requirements

Enclosure Requirements

The SBI-4119MG-X blade module requires one of the following enclosures to run in:
 SBE-820C-XXX SBE-820J-XXX SBE-820L-XXX

See the Supermicro website for details on enclosures at:
<https://www.supermicro.com/en/products/superblade/enclosure>

Note: The SBI-4119MG-X blade module also requires one or more power supplies in the enclosure to run the blade module. Available SuperBlade power supplies can be found on the Supermicro website at:
<https://www.supermicro.com/products/SuperBlade/powersupply/>.

CPU and Heat Sink Installation

Processor and Heatsink Installation

Warning: When handling the processor package, avoid placing direct pressure on the LGA lands (gold contacts) of the CPU or CPU socket. Improper installation or socket misalignment can cause serious damage to the CPU or motherboard, which may result in RMA repairs. Please read and follow all instructions thoroughly before installing your CPU and heatsink.

Important:

- Always connect the power cord last, and unplug it before adding, removing, or changing any hardware components. You must install the processor into the CPU socket before you install the heatsink.
- If you buy a CPU separately, make sure that you use an Intel-certified multi-directional heatsink only.
- Install the motherboard into the chassis before you install the CPU heatsink.
- When receiving a motherboard with a pre-installed processor, check that a plastic protective cover is on the CPU socket and none of the socket pins are bent. If they are, contact your retailer.
- Refer to the Supermicro website for updates on CPU support.

Installing the LGA 1151 Processor

1. Press the load lever down to release the load plate from its locking position.

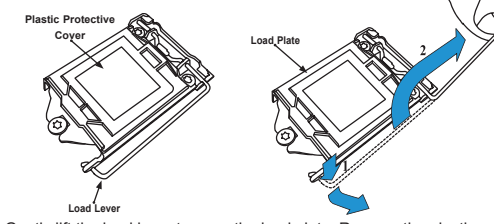

2. Gently lift the load lever to open the load plate. Remove the plastic protective cover. Do not touch the CPU socket contacts.

3. Locate the triangle on the CPU and CPU socket, which indicates the location of Pin 1. Holding the CPU by the edges with your thumb and index finger, align the triangle on the CPU with the triangle on the socket. The CPU keys (the semi-circle cutouts) may also be aligned against the socket keys as a guide.

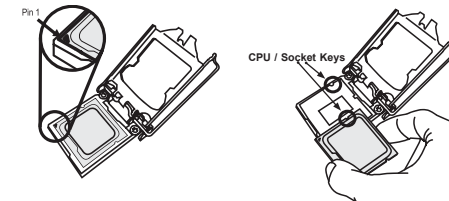

4. Carefully lower the CPU straight down into the socket. Do not drop the CPU on the socket, or move it horizontally or vertically to avoid damaging the CPU or socket. Inspect the four corners of the CPU to make sure that the CPU is properly installed.

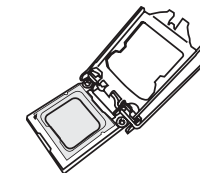

5. Close the load plate, then gently push down the load lever into its locking position.

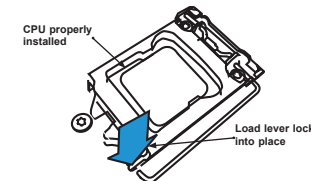

Note: You can only install the CPU in one direction. Make sure it is properly inserted into the socket before closing the load plate. If it doesn't close properly, do not force it as it may damage your CPU. Instead, open the load plate again and double-check that the CPU is properly aligned.

Installing a Passive CPU Heatsink

1. Do not apply any thermal grease to the heatsink or the CPU die -- the required amount has already been applied.

2. Place the heatsink on top of the CPU so that the four mounting holes are aligned with those on the motherboard and the heatsink bracket underneath.

3. Screw in two diagonal screws (e.g., the #1 and the #2 screws) until just snug. Do not over-tighten the screws to avoid damaging the CPU and the motherboard.

4. Finish the installation by fully tightening all four screws.

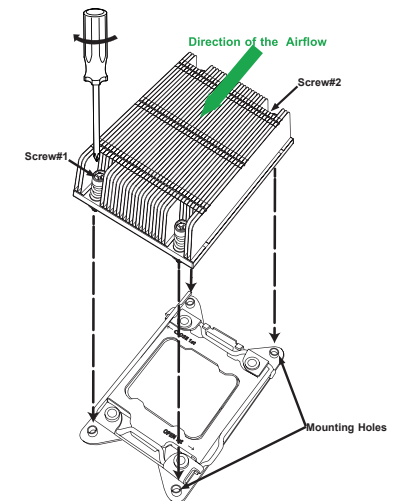

Note: For optimal airflow, please follow your chassis airflow direction to correctly install the CPU heatsink. Graphic drawings included in this manual are for reference only. They might look different from the components installed in your system.

Removing the CPU and the Heatsink

Warning: We do not recommend that the CPU or the heatsink be removed. However, if you do need to uninstall the CPU or the heatsink, please follow the instructions below to uninstall the heatsink or the CPU without damaging the CPU or the motherboard.

1. Unscrew the heatsink screws from the motherboard in the sequence as shown in the illustration below.

2. Gently wriggle the heatsink to loosen it from the CPU socket. Do not use excessive force when loosening the heatsink!

3. Once the heatsink is loosened, remove it from the socket. Once the heatsink is removed, remove the CPU from the socket as needed.

4. Remove the used thermal grease and clean the surface of the CPU and the heatsink. Reapply the proper amount of thermal grease on the surface before reinstalling the CPU and the heatsink as needed.

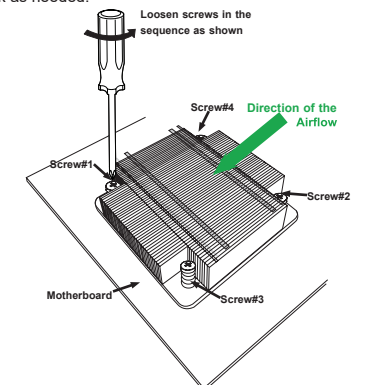

Note 1: To optimize airflow, please follow your chassis airflow direction to properly install the heatsink.

Note 2: Graphics shown in this manual are for reference only. They may or may not look the same as the components installed in your system.

