

# SUPERMICR SuperServer 1029U-TN12RV Quick Reference Guide

## Board Layout

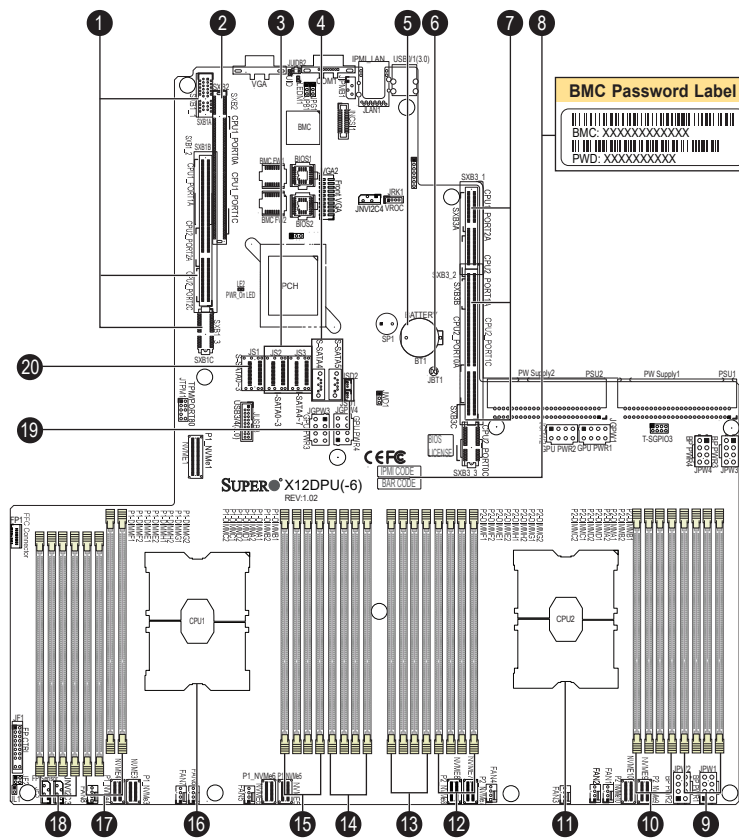

No.	Description
1	SXB1A/B/C: Proprietary PCI-e Slot used for WIO-Left Devices (supported by CPU2)
2	SXB2: Proprietary PCI-e Slot for WIO-Right Devices (supported by CPU2)
3	I-SATA0~3, I-SATA4~7: SATA 3.0 Ports (Intel PCH)
4	S-SATA 4, 5: SATA 3.0 Ports (Intel SCU)
5	BT1 : Onboard CMOS battery
6	JBT1: CMOS Clear
7	SXB3A/B/C: Proprietary PCI-e Slot for Ultra Riser Devices (supported by CPU1)
8	BMC Password Label
9	P2-DIMMB1/P2-DIMMB2/P2-DIMMA1/P2-DIMMA2 slot
10	P2-DIMMD1/P2-DIMMD2/P2-DIMMC1/P2-DIMMC2 slot
11	CPU2
12	P2-DIMMG2/P2-DIMMG1/P2-DIMMH2/P2-DIMMH1 slot
13	P2-DIMME2/P2-DIMME1/P2-DIMMF2/P2-DIMMF1 slot
14	P1-DIMMB1/P1-DIMMB2/P1-DIMMA1/P1-DIMMA2 slot
15	P1-DIMMD1/P1-DIMMD2/P1-DIMMC1/P1-DIMMC2 slot
16	CPU1 (Install CPU1 first)
17	P1-DIMMG2/P1-DIMMG1/P1-DIMMH2/P1-DIMMH1 slot
18	P1-DIMME2/P1-DIMME1/P1-DIMMF2/P1-DIMMF1 slot
19	JSD1/JSD2: SATA DOM (Device_on_Module) Power Connectors
20	S-SATA0~3: SATA 3.0 Ports (Intel SCU)

## Memory Support

Memory Population Table

When 2 CPUs are used	Memory Population Sequence
2 CPUs & 2 DIMMs	CPU1: P1-DIMMA1 CPU2: P2-DIMMA1
2 CPUs & 4 DIMMs	CPU1: P1-DIMMA1/P1-DIMMD1 CPU2: P2-DIMMA1/P2-DIMMD1
2 CPUs & 6 DIMMs	CPU1: P1-DIMMC1/P1-DIMMB1/P1-DIMMA1 CPU2: P2-DIMMC1/P2-DIMMB1/P2-DIMMA1
2 CPUs & 8 DIMMs	CPU1: P1-DIMMB1/P1-DIMMA1/P1-DIMMD1/P1-DIMME1 CPU2: P2-DIMMB1/P2-DIMMA1/P2-DIMMD1/P2-DIMME1
2 CPUs & 10 DIMMs	CPU1: P1-DIMMC1/P1-DIMMB1/P1-DIMMA1/P1-DIMMD1/P1-DIMME1/P1-DIMMF1 CPU2: P2-DIMMB1/P2-DIMMA1/P2-DIMMD1/P2-DIMME1
2 CPUs & 12 DIMMs	CPU1: P1-DIMMC1/P1-DIMMB1/P1-DIMMA1/P1-DIMMD1/P1-DIMME1/P1-DIMMF1 CPU2: P2-DIMMC1/P2-DIMMB1/P2-DIMMA1/P2-DIMMD1/P2-DIMME1/P2-DIMMF1
2 CPUs & 14 DIMMs	CPU1: P1-DIMMB1/P1-DIMMB2/P1-DIMMA1/P1-DIMMA2/P1-DIMMD2/P1-DIMMD1/P1-DIMME2/P1-DIMME1 CPU2: P2-DIMMC1/P2-DIMMB1/P2-DIMMA1/P2-DIMMD1/P2-DIMME1/P2-DIMMF1
2 CPUs & 16 DIMMs	CPU1: P1-DIMMB1/P1-DIMMB2/P1-DIMMA1/P1-DIMMA2/P1-DIMMD2/P1-DIMMD1/P1-DIMME2/P1-DIMME1 CPU2: P2-DIMMB1/P2-DIMMB2/P2-DIMMA1/P2-DIMMA2/P2-DIMMD2/P2-DIMMD1/P2-DIMME2/P2-DIMME1
2 CPUs & 18 DIMMs	CPU1: P1-DIMMC1/P1-DIMMC2/P1-DIMMB1/P1-DIMMB2/P1-DIMMA1/P1-DIMMA2/P1-DIMMD2/P1-DIMMD1/ P1-DIMME2/P1-DIMME1/P1-DIMMF2/P1-DIMMF1 CPU2: P2-DIMMC1/P2-DIMMC2/P2-DIMMB1/P2-DIMMB2/P2-DIMMA1/P2-DIMMA2/P2-DIMMD2/P2-DIMMD1/ P2-DIMME2/P2-DIMME1/P2-DIMMF2/P2-DIMMF1
2 CPUs & 20 DIMMs	CPU1: P1-DIMMC1/P1-DIMMC2/P1-DIMMB1/P1-DIMMB2/P1-DIMMA1/P1-DIMMA2/P1-DIMMD2/P1-DIMMD1/ P1-DIMME2/P1-DIMME1/P1-DIMMF2/P1-DIMMF1 CPU2: P2-DIMMC1/P2-DIMMC2/P2-DIMMB1/P2-DIMMB2/P2-DIMMA1/P2-DIMMA2/P2-DIMMD2/P2-DIMMD1/ P2-DIMME2/P2-DIMME1/P2-DIMMF2/P2-DIMMF1
2 CPUs & 22 DIMMs (Unbalanced: not recommended)	CPU1: P1-DIMMC1/P1-DIMMC2/P1-DIMMB1/P1-DIMMB2/P1-DIMMA1/P1-DIMMA2/P1-DIMMD2/P1-DIMMD1/ P1-DIMME2/P1-DIMME1/P1-DIMMF2/P1-DIMMF1 CPU2: P2-DIMMC1/P2-DIMMC2/P2-DIMMB1/P2-DIMMB2/P2-DIMMA1/P2-DIMMA2/P2-DIMMD2/P2-DIMMD1/ P2-DIMME2/P2-DIMME1/P2-DIMMF2/P2-DIMMF1
2 CPUs & 24 DIMMs	CPU1: P1-DIMMC1/P1-DIMMC2/P1-DIMMB1/P1-DIMMB2/P1-DIMMA1/P1-DIMMA2/P1-DIMMD2/P1-DIMMD1/ P1-DIMME2/P1-DIMME1/P1-DIMMF2/P1-DIMMF1 CPU2: P2-DIMMC1/P2-DIMMC2/P2-DIMMB1/P2-DIMMB2/P2-DIMMA1/P2-DIMMA2/P2-DIMMD2/P2-DIMMD1/ P2-DIMME2/P2-DIMME1/P2-DIMMF2/P2-DIMMF1

## Rear View

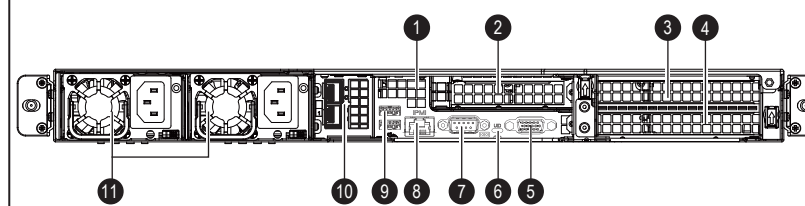

No.	Description
1	Slot 1, Ultra Riser Networking Slot (CPU1)
2	Slot 2, PCI-E 3.0 x16 Internal LP Slot (CPU1)
3	Slot 3, PCI-E 3.0 x8 LP Slot (CPU2)
4	Not Available
5	VGA port
6	UID Button (Unit Identifier Button)
7	COM Port
8	Dedicated LAN for IPMI
9	2x USB 3.0 Ports
10	2-4 LAN Port (Reference LAN port configuration table)
11	Redundant Power Supply Module (See user manual for LED guidance)

LAN Port Configurations for 1029U-TN12RV

LAN Ports	Ultra Riser Card	Rear I/O Window
Two 25G SFP28	AOC-URN4-M2TS	MCP-240-81915-0N
Two 10GBase-T	AOC-URN4-B2XT	MCP-240-81909-0N
No LAN	AOC-URN4	MCP-240-81916-0N

## Front view

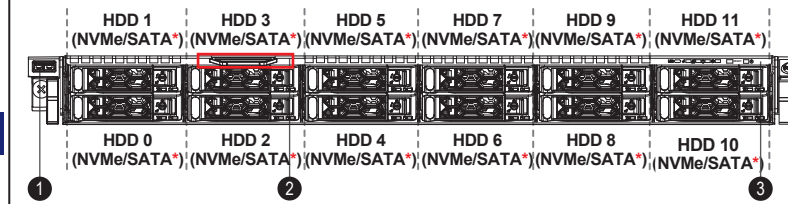

No.	Description	No.	Description
1	USB 3.0 Port	2	Service/Asset Tag
3	Control Panel		

\* 0-5 NVMe from CPU1, 6-11 NVMe from CPU2  
\*\* SAS3 support available with additional parts; see optional parts list

No.	Description	No.	Description
1	UID Button	2	Universal Information LED
3	NIC1 LED	4	Device Activity LED
5	Power LED	6	Reset Button
7	Power Button		

## Beep Codes

Beep Code	Error Message	Description
1 beep	Refresh	Circuits have been reset (Ready to power up)
5 short and 1 long	Memory error	No memory detected in the system
5 long and 2 short	Display memory read/write error	Video adapter missing or with faulty memory
1 long continuous	System OH	System overheat condition

## Caution

**SAFETY INFORMATION**  
IMPORTANT: See installation instructions and safety warning before connecting system to powersupply.  
[http://www.supermicro.com/about/policies/safety\\_information.cfm](http://www.supermicro.com/about/policies/safety_information.cfm)

**WARNING:**  
To reduce risk of electric shock/damage to equipment, disconnect power from server by disconnecting all power cords from electrical outlets.  
If any CPU socket empty, install protective plastic CPU cap.

**CAUTION:**  
Always be sure all power supplies for this system have the same power output. If mixed power supplies are installed, the system will not operate.

For more information go to: <http://www.supermicro.com/support>

## BMC Password Label

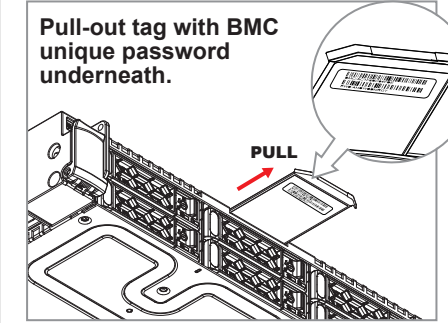

Each system comes with a unique default password for the ADMIN user. This can be found on a sticker on the motherboard and a sticker underneath the service tag on chassis. If necessary, the password can be reset by the Supermicro IPMICFG tool.

For more information, please visit <https://www.supermicro.com/en/solutions/management-software/bmc-resources>

## CPU Installation

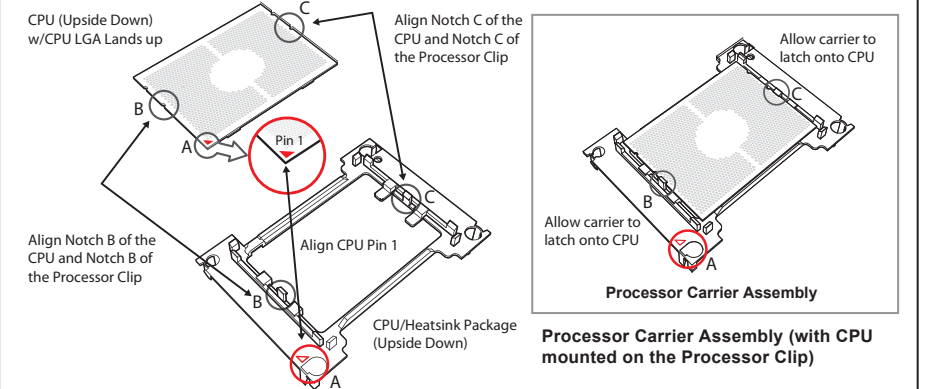

## Attaching the Processor Carrier Assembly to the Heatsink to Form the Processor Heatsink Module (PHM)

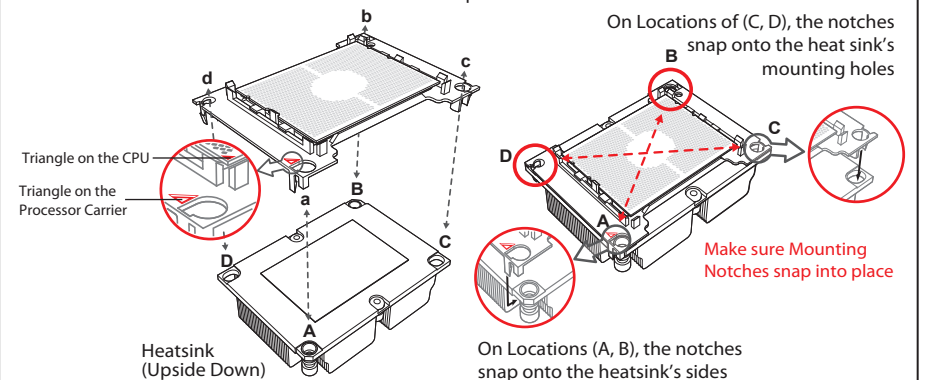

## Removing the Dust Cover from the CPU Socket

Remove the dust cover from the CPU socket, exposing the socket and socket pins as shown on the illustration below. **Note:** Do not use excessive force when tightening the screws to avoid damaging the LGA lands and the processor.

