

SUPERMICR[®] SuperServer 1027GR-TRF/TRFT/TSF/TSFT/TQF/TQFT/-FM375/-FM309 Quick Reference Guide

Board Layout

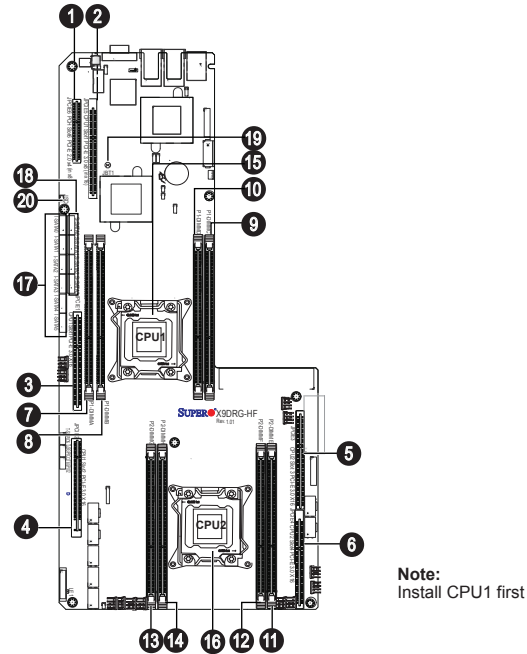

Note:
Install CPU1 first

No.	Description	No.	Description
1	PCH Slot6 PCI-E 2.0 x4 (in x8)	11	P2-DIMME slot
2	CPU1 Slot5 PCI-E 3.0 x8 (in x16)	12	P2-DIMMF slot
3	CPU1 Slot1 PCI-E 3.0 x16	13	P2-DIMMG slot
4	CPU1 Slot2 PCI-E 3.0 x16	14	P2-DIMMH slot
5	CPU2 Slot3 PCI-E 3.0 x16	15	CPU1 (Install CPU1 first)
6	CPU2 Slot4 PCI-E 3.0 x16	16	CPU2
7	P1-DIMMA slot	17	SATA 3.0 (I-SATA 0/1)
8	P1-DIMMB slot	18	SATA 2.0 (I-SATA 2~5)
9	P1-DIMMC slot	19	JBT1 = CMOS Reset
10	P1-DIMMD slot	20	JDS1= SATA DOM Power

MEMORY

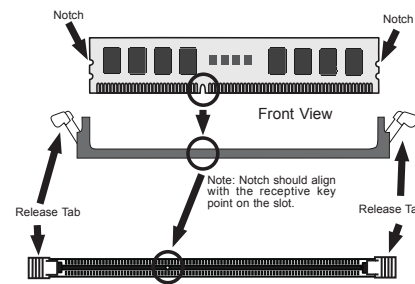

Top View of DDR3 Slot

Processors and their Corresponding DIMMs

CPU#	Corresponding DIMM Modules			
CPU 1	P1-A1	P1-B1	P1-C1	P1-D1
CPU2	P2-E1	P2-F1	P2-G1	P2-H1

Populating DIMMs

Number of CPUs+DIMMs	CPU and DIMM Population Configuration Table (For memory to work proper, please install DIMMs in pairs)
1 CPU & 2 DIMMs	CPU1 P1-A1/P1-B1
1 CPU & 4 DIMMs	CPU1 P1-A1/P1-B1, P1-C1/P1-D1
2 CPUs & 4 DIMMs	CPU1 + CPU2 P1-A1/P1-B1, P2-E1/P2-F1
2 CPUs & 6 DIMMs	CPU1 + CPU2 P1-A1/P1-B1/P1-C1/P1-D1, P2-E1/P2-F1
2 CPUs & 8 DIMMs	CPU1 + CPU2 P1-A1/P1-B1/P1-C1/P1-D1, P2-E1/P2-F1/P2-G1/P2-H1

RDIMM Support POR

DIMM Slots per Channel	DIMMs Populated per DDR Channel	RDIMM Type (RDIMM = Registered DIMMs)	POR Speeds (in MHz)	Ranks per DIMM (Any Combination)
1	1	Reg. ECC DDR3	800/1066/1333/1600	SR, DR, or QR
2	1	Reg. ECC DDR3	800/1066/1333/1600	SR, DR, or QR
2	2	Reg. ECC DDR3	800/1066/1333/1600	Mixing SR, DR, QR

Population Rules:

- Any combination of x4 and x8 RDIMMs with 1 Gb or 2 Gb DRAM density are supported.
- Populate DIMMs starting with DIMM A1.
- When mixing QR with SR or DR on the same DDR channel, put the QR in DIMMA1 first.

Front view & Interface

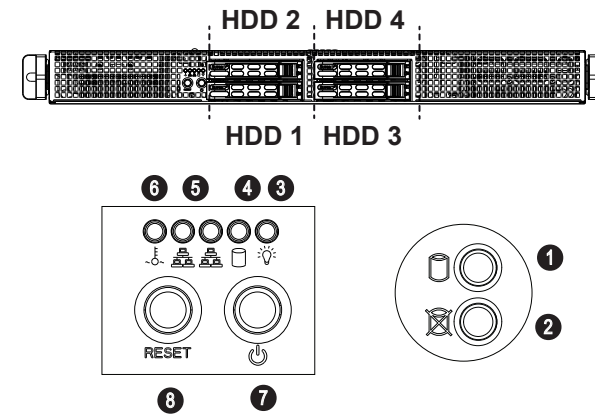

No.	Description
1	Hard Drive Signal
2	Hard Drive Fail
3	Power LED
4	Device Activity LED
5	LAN1 LED & LAN2 LED
6	Overheat & Fan Fail LED
7	Power Button
8	Reset Button

Rear View

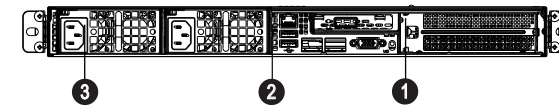

No.	Description
1	PCI Expansion Slot (w/riser card)
2	Dedicated LAN for IPMI
3	Power Supply Module

Beep Codes

BIOS Beep Codes		
Beep Code/LED	Message	Description
1 beep	Refresh	Circuits have been reset. (Ready to power up)
5 short beeps + 1 long beep	Memory	No memory detected
5 long beeps + 2 short beeps	Display memory read/write status	Video adapter missing or with faulty memory
1 continuous beep	System	System overheat

CPU Installation

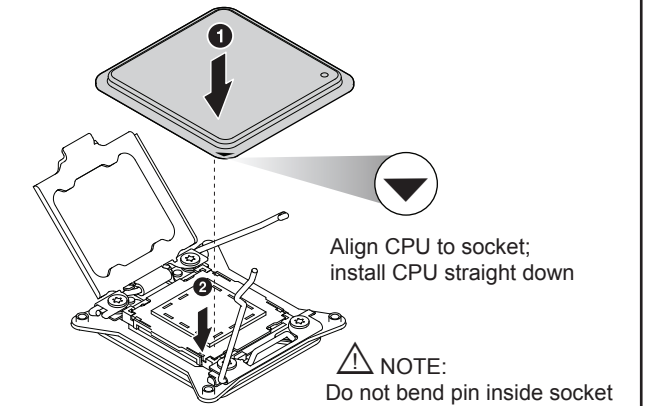

Align CPU to socket;
install CPU straight down

NOTE:
Do not bend pin inside socket

Heatsink Installation

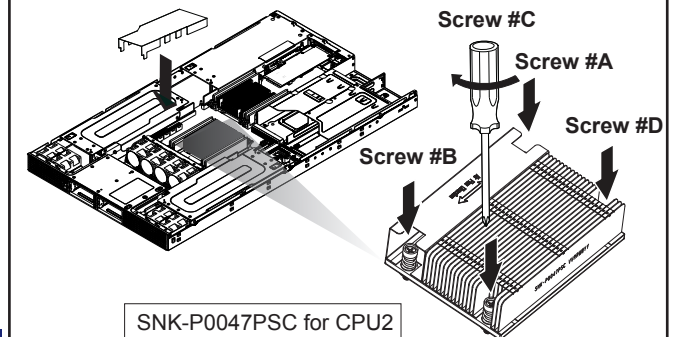

SNK-P0047PSC for CPU2

- Place heatsink on top of installed CPU
- Line up the four screws to socket
- Push down heatsink and screw down as shown (cross pattern, in order: A, C, B, D)
- NOTE: Only use 6-8 lb/f of torque; otherwise, hand-tighten each screw, to avoid damaging the system

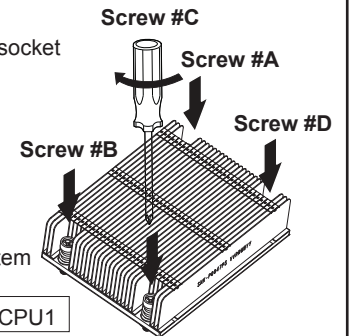

SNK-P0047PS for CPU1

Caution

SAFETY INFORMATION
IMPORTANT: See installation instructions and safety warning before connecting system to power supply.
http://www.supermicro.com/about/policies/safety_information.cfm

WARNING:
To reduce risk of electric shock/damage to equipment, disconnect power from server by disconnecting all power cords from electrical outlets.
If any CPU socket empty, install protective plastic CPU cap

CAUTION:
Always be sure all power supplies for this system have the same power output. If mixed power supplies are installed, the system will not operate.

For more information go to :
<http://www.supermicro.com/support>

Installing Graphics (GPU) Cards

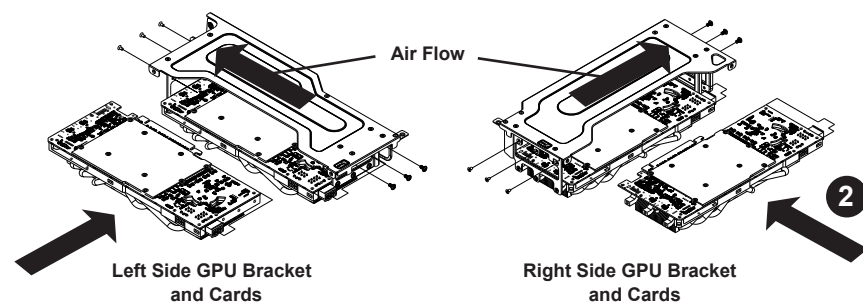

- Identify the left and right brackets and graphics cards as illustrated above.
- Insert the graphics cards into the brackets, aligning the mounting holes in the graphics cards with the mounting holes in the brackets.
- Secure each card to the bracket using the six screws which are included for this purpose.
- Carefully position each bracket in the chassis, aligning the four mounting holes in the top and side of each bracket with the corresponding mounting holes in the chassis.
- Secure the bracket to the chassis by using the screws provided.
- After a GPU card is installed, you must connect it to one of the following power headers on the serverboard: JPW3, JPW4, JPW6, JPW7, JPW8 or JPW11

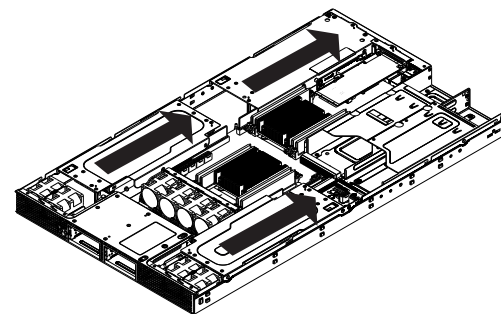

In order to install the kepler K10 in the system

- Please remove the K10 back bracket and add the washers that come with the GPU package. Add a washer between the plate and the PCB for each screw. See NVIDIA's web site for more details on the K10 GPU specifications.
- The system comes with Fermi brackets already installed by default. If replacing Fermi GPUs with Kepler GPUs, remove the Fermi bracket holder from the chassis and replace with the Kepler bracket holder which comes with the accessory (MCP-240-00117-0N)
- Pay attention to the airflow arrows on the Kepler cards to install each card into the correct side of the chassis.
- The card with the arrow pointing toward the Tesla logo on the Kepler should go on the left side of the chassis.
- The card with the arrow pointing away from the Tesla logo should go on the right side of the chassis (when viewed from the front of the system).

