

SUPERMICR[®] SuperServer 120TP-DTTR/DC8TR/DC9TR Quick Reference Guide

Board Layout

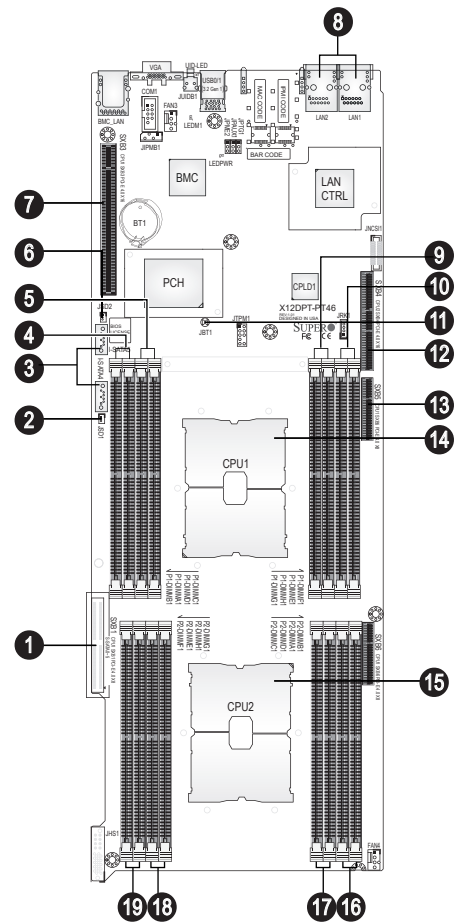

No.	Description
1	SXB1 : PCIe 4.0 x8 Slot supported by CPU1 for Supermicro proprietary riser card and six SATA connections (S-SATA0 - S-SATA5) supported by PCH
2	JSD1 : SATA DOM (Disk-On-Module) Power Connector
3	Intel PCH Powered I-SATA 3.0 Ports with support for SuperDOM (Disk on Module) devices
4	P1-DIMMB1/P1-DIMMA1 slot
5	P1-DIMMD1/P1-DIMMC1 slot
6	JSD2 : SATA DOM (Disk-On-Module) Power Connector
7	SXB3 : PCIe 4.0 x16 Slot supported by CPU1 for the Supermicro proprietary riser card
8	LAN1, LAN2 : 10Gb Base-T Ethernet Ports
9	P1-DIMMG1/P1-DIMMH1 slot
10	P1-DIMME1/P1-DIMMF1 slot
11	JBT1: CMOS Clear
12	SXB4 : PCIe 4.0 x16 Slot supported by CPU2 for the Supermicro proprietary riser card
13	SXB5 : PCIe 4.0 x8 Slot supported by CPU1
14	CPU1 (Install CPU1 first)
15	CPU2
16	P2-DIMMB1/P2-DIMMA1 slot
17	P2-DIMMD1/P2-DIMMC1 slot
18	P2-DIMMG1/P2-DIMMH1 slot
19	P2-DIMME1/P2-DIMMF1 slot

Memory Support

DDR4 Memory Support for 3rd Gen Intel Xeon Scalable Processors					
Type	Ranks Per DIMM and Data Width	DIMM Capacity (GB)		Speed (MT/s) and Voltage	
		DRAM Density		One DIMM per Channel	
		8Gb	16Gb	1.2V	
RDIMM	SRx8	8GB	16GB	3200*	
	SRx4	16GB	32GB		
	DRx8	16GB	32GB		
	DRx4	32GB	64GB		
RDIMM 3Ds	(4R/8R) x4	2H-64GB	2H-128GB		
		4H-128GB	4H-256GB		
LRDIMM	QRx4	64GB	128GB		
LRDIMM 3Ds	(4R/8R) x4	4H-128GB	2H-128GB		
			4H-256GB		

Memory Population for DDR4-only Configurations, 16 DIMM Slots	
CPUs/DIMMs	DIMM Slots
1 CPU & 1 DIMM	A1
1 CPUs & 2 DIMMs*	A1, E1
1 CPUs & 4 DIMMs*	A1, C1, E1, G1
1 CPUs & 6 DIMMs	A1, B1, C1, E1, F1, G1
2 CPUs & 8 DIMMs*	A1, B1, C1, D1, E1, F1, G1, H1
2 CPUs & 2 DIMMs*	CPU1: A1 CPU2: A1
2 CPUs & 4 DIMMs*	CPU1: A1, E1 CPU2: A1, E1
2 CPUs & 6 DIMMs	CPU1: A1, C1, E1, G1 CPU2: A1, E1
2 CPUs & 8 DIMMs*	CPU1: A1, C1, E1, G1 CPU2: A1, C1, E1, G1
2 CPUs & 10 DIMMs	CPU1: A1, B1, C1, E1, F1, G1 CPU2: A1, C1, E1, G1
2 CPUs & 12 DIMMs*	CPU1: A1, B1, C1, E1, F1, G1 CPU2: A1, B1, C1, E1, F1, G1
2 CPUs & 14 DIMMs	CPU1: A1, B1, C1, D1, E1, F1, G1, H1 CPU2: A1, B1, C1, E1, F1, G1
2 CPUs & 16 DIMMs*	CPU1: A1, B1, C1, D1, E1, F1, G1, H1 CPU2: A1, B1, C1, D1, E1, F1, G1, H1

* recommended for optimal performance

Front view & Interface



Drive Bay(Node A-B)	Description
0 ~ 3	4x 2.5" Hot-Swap SATA/SAS Drive Bays

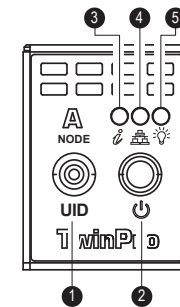

No.	Description
1	UID Button
2	Power Button
3	Information LED
4	NIC LED
5	Power LED

Nodes and Corresponding Hard Drives

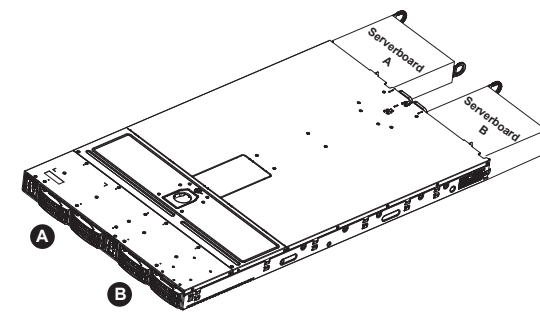

Serverboard Drawer Locations in the Chassis

Serverboard A Controls HDDs A0 through A4

Serverboard B Controls HDDs B0 through B4

Rear View

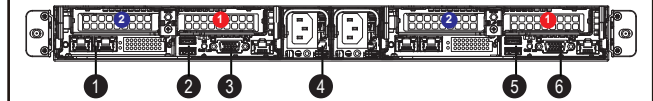

No.	Description
1 2	PCI-E 4.0 x16 Low Profile Slot
1	2 RJ45 10G Ports
2	2 USB Ports
3	VGA Port
4	Redundant 1000W Titanium Level Power Supplies
5	UID Button
6	Dedicated BMC LAN Port

Air Shroud installation

Air shrouds concentrate airflow to maximize cooling efficiency

1. Screw the guide pins into the sled as shown below.
2. Position the air shrouds and drop them onto the guide pins and into place.

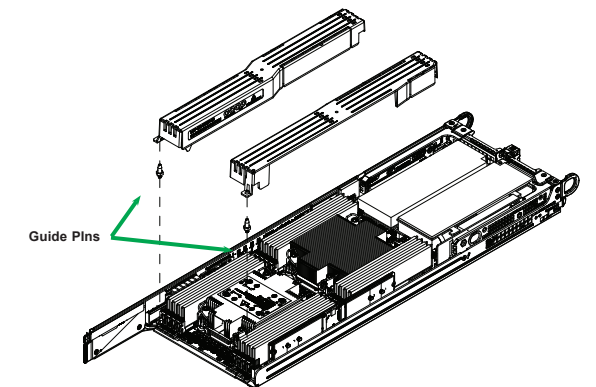

Heatsink Installation

Remove the plastic protective cover from the CPU socket. Gently squeeze the grip tabs then pull the cover off.

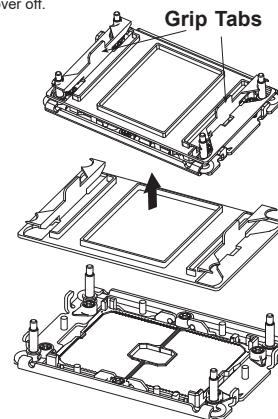

Locate four threaded fasteners (a, b, c, d) on the CPU socket.

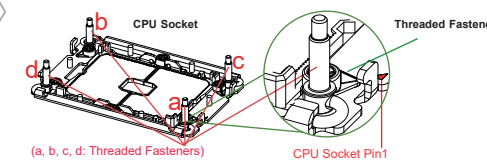

Locate four PEEK nuts (A, B, C, D) and four rotating wires (1, 2, 3, 4) on the heatsink as shown below.

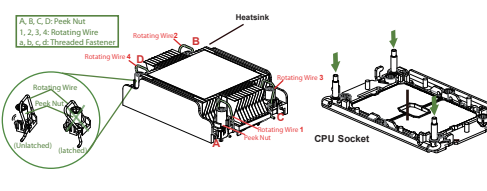

Align nut A (next to the triangles and pin 1) on the heatsink with threaded fastener "a" on the CPU socket. Also align nuts B, C, D on the heatsink with threaded fasteners b, c, d on the CPU socket. Gently place the heatsink on the CPU socket, making sure that each nut is properly aligned with its corresponding threaded fastener.

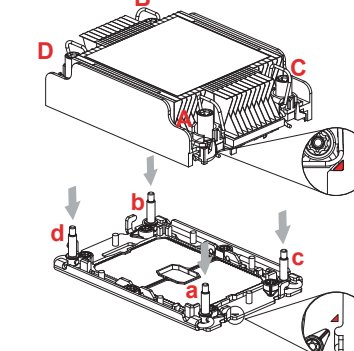

Press all four rotating wires outward to latch the PHM onto the CPU socket.

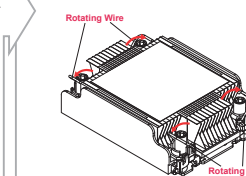

With a t30-bit screwdriver, tighten all PEEK nuts in the sequence of A, B, C, and D with even pressure not greater than 12 lbf-in.

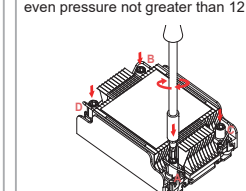

Caution and Product Resources

SAFETY INFORMATION:

IMPORTANT: See installation instructions and safety warning before connecting system to power supply.
http://www.supermicro.com/about/policies/safety_information.cfm

WARNING:

To reduce risk of electric shock/damage to equipment, disconnect power from server by disconnecting all power cords from electrical outlets. If any CPU socket empty, install protective plastic CPU cap.

CAUTION:

Always be sure all power supplies for this system have the same power output. If mixed power supplies are installed, the system will not operate.

CAUTION:

This unit has redundant power sources. Please disconnect all the power cords before servicing.

PRODUCT RESOURCES:

For more information go to: <http://www.supermicro.com/support>

