

SUPERMICR SuperServer 511E-WR Quick Reference Guide

Board Layout

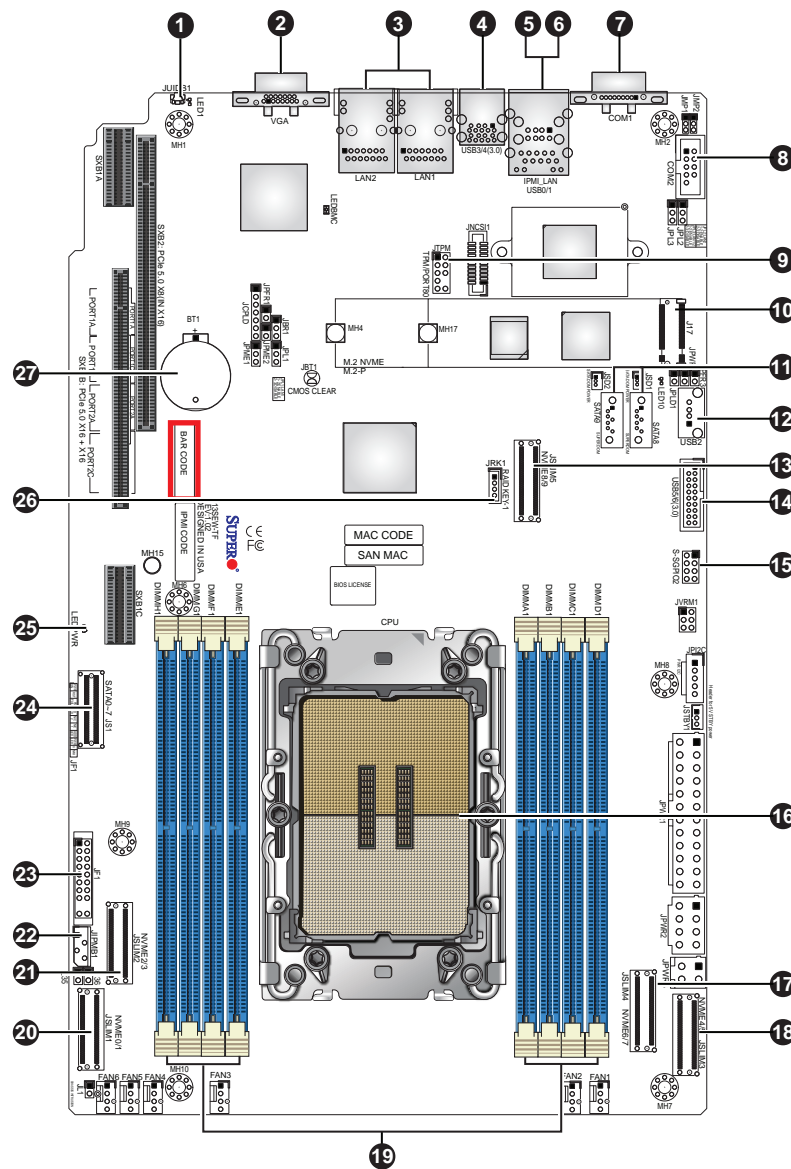

Item	Description	Item	Description
1	UID Button (Unit Identifier Button)	15	S-SGPIO2 Header
2	VGA Port	16	CPU
3	2 1GbE LAN Ports	17	NVME 6/7: PCIe 5.0 x8 MCIO Connector
4	USB 3.2 Gen 1 Ports	18	NVME 4/5: PCIe 5.0 x8 MCIO Connector
5	Dedicated LAN for IPMI	19	DIMM A1-H1 slots
6	USB 2.0 Ports	20	NVME 0/1: PCIe 5.0 x8 MCIO Connector
7	COM Port (Serial Port)	21	NVME 2/3: PCIe 5.0 x8 MCIO Connector
8	COM Port Header (Serial Port)	22	JIPMB1 4-pin BMC External I2C Header
9	TPM Header	23	Front Control Panel Header
10	M.2 PCI-E 3.0 Interface	24	SATA 0-7: SlimSAS SATA 3.0 Ports
11	SATA 8-9: SATA 3.0 Ports with SuperDOM power	25	Onboard Power LED
12	USB 2.0 TypeA Header	26	Intel RAID Key Header
13	NVME 8/9: PCIe 5.0 x8 MCIO Connector	27	Onboard CMOS Battery
14	USB 3.2 Gen 1 Header		

Front View and Features

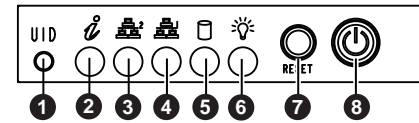
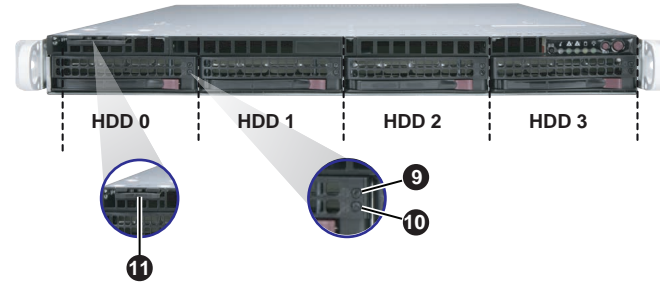

Control Panel Features	
Item	Description
1	UID Button
2	Information LED
3	NIC2 LED
4	NIC1 LED
5	HDD LED
6	Power LED
7	Reset Button
8	Power Button
9	Drive Activity LED
10	Drive Status LED
11	Service/Asset Tag (pull-out identifier with BMC ADMIN default password underneath)

Rear View and Features

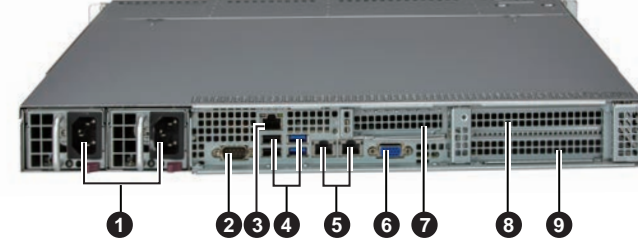

Item	Description
1	Redundant Power Supply Modules
2	Serial Port
3	Dedicated IPMI Port
4	Two USB 3.2 Gen1 and Two USB 2.0 (black) Ports
5	LAN 1 (left) and LAN 2 (right) Ports
6	VGA Port
7	PCI-E 5.0 x8 (in x16) Expansion Slot 3 (LP)
8	PCI-E 5.0 x16 Expansion Slot 1 (FHFL)
9	PCI-E 5.0 x16 Expansion Slot 2 (FHFL)

Caution and Product Resources

- SAFETY INFORMATION:**
IMPORTANT: See installation instructions and safety warning before connecting system to power supply.
http://www.supermicro.com/about/policies/safety_information.cfm
- CAUTION:**
Always be sure all power supplies for this system have the same power output. If mixed power supplies are installed, the system will not operate.
- WARNING:**
To reduce risk of electric shock/damage to equipment, disconnect power from server by disconnecting all power cords from electrical outlets. If any CPU socket empty, install protective plastic CPU cap.
- CAUTION:**
This unit has redundant power sources. Please disconnect all the power cords before servicing.

Memory

DIMM Installation

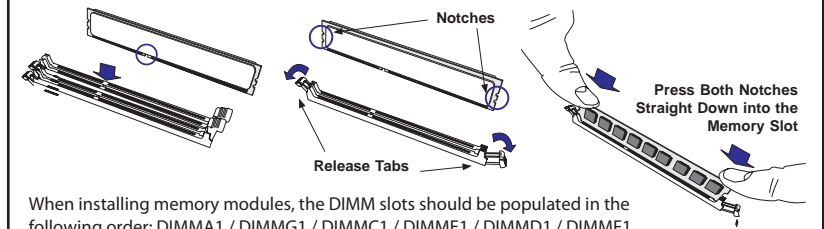

When installing memory modules, the DIMM slots should be populated in the following order: DIMMA1 / DIMMG1 / DIMMC1 / DIMME1 / DIMMD1 / DIMMF1 / DIMMB1 / DIMMH1.
-Always use DDR5 DIMM modules of the same type, size, and speed.
-Mixed DIMM speeds can be installed. However, all DIMMs will run at the speed of the slowest DIMM.

1 CPU, 8-DIMM Slots	
Number of DIMMs	Memory Population Sequence
1	DIMMA1
2	DIMMA1 / DIMMG1
4	DIMMA1 / DIMMG1 / DIMMC1 / DIMME1
6	DIMMA1 / DIMMG1 / DIMMC1 / DIMME1 / DIMMD1 / DIMMF1
8	DIMMA1 / DIMMG1 / DIMMC1 / DIMME1 / DIMMD1 / DIMMF1 / DIMMB1 / DIMMH1

BMC Password Label

Pull-out tag with BMC unique password and Serial Number Label underneath.

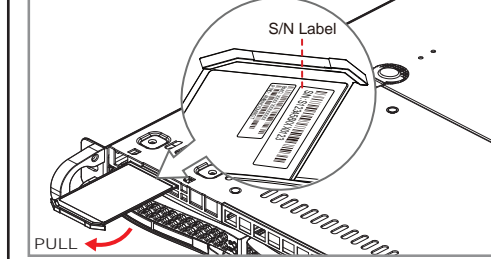

Each system comes with a unique default password for the ADMIN user. This can be found on a sticker on the motherboard and a sticker underneath the service tag on chassis. If necessary, the password can be reset by the Supermicro IPMICFG tool.
For more information, please visit <https://www.supermicro.com/en/solutions/management-software/bmc-resources>

CPU Installation, Supports a single Intel Xeon Sapphire Rapids Scalable Processor (LGA 4677)

A. Creating the Intel Sapphire Rapids CPU Carrier Assembly

1. Locate small gold triangle (Pin 1) on processor and corresponding hollowed triangle on carrier.
2. Using the triangles as a guide, carefully align and place Point A of the processor into the carrier. Gently snap into place to fasten onto Point B.

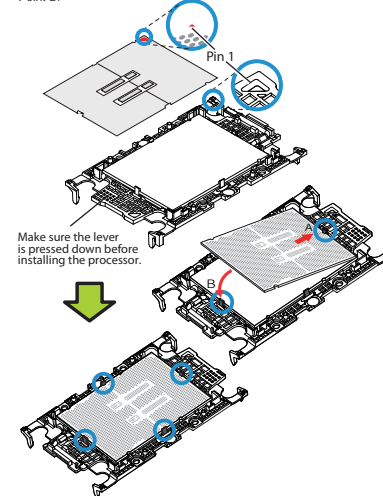

B. Assembling the Processor Heatsink Module (PHM)

1. If this is a new heatsink, the thermal grease has been preapplied. Otherwise, apply the proper amount of thermal grease.
2. Hold the processor carrier assembly so the processor's gold contacts are facing up, then align the holes of the processor carrier assembly with the holes on the heatsink. Press the processor carrier assembly down until it snaps into place. The plastic clips of the processor carrier assembly will lock at the four corners.
3. Examine all corners to ensure that the plastic clips on the processor carrier assembly are firmly attached to the heatsink.

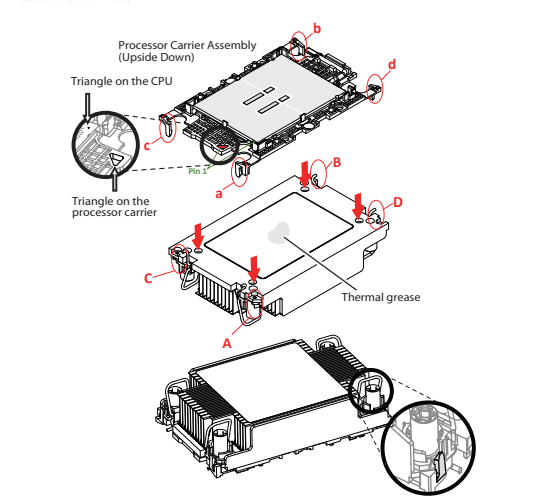

Check each corner to ensure that the processor carrier is firmly attached to the heatsink.

C. Preparing the CPU Socket for Installation

- Gently pull off the plastic protective cover by one corner to remove it from the CPU socket.

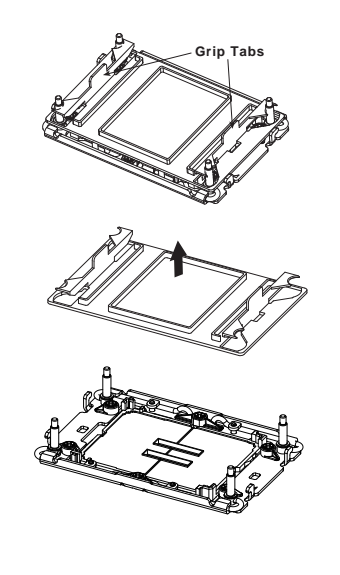

D. Installing the Process Heatsink Module

1. Locate four threaded fasteners (a, b, c, d) on the CPU socket.

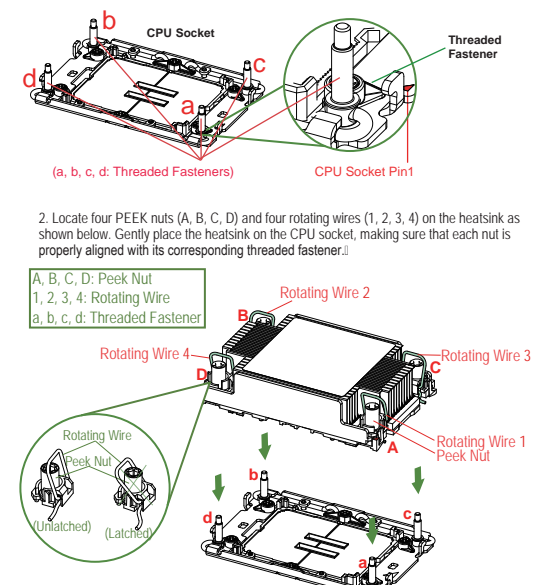

3. Press all four rotating wires outward to latch the PHM onto the CPU socket.

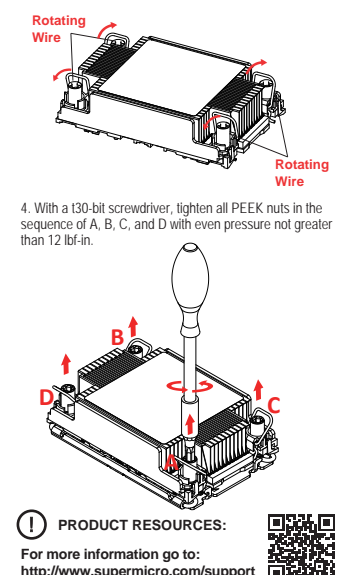

PRODUCT RESOURCES:
For more information go to: <http://www.supermicro.com/support>

