

SUPERMICR SuperServer E302-12D-4C/8C Series Quick Reference Guide

Board Layout

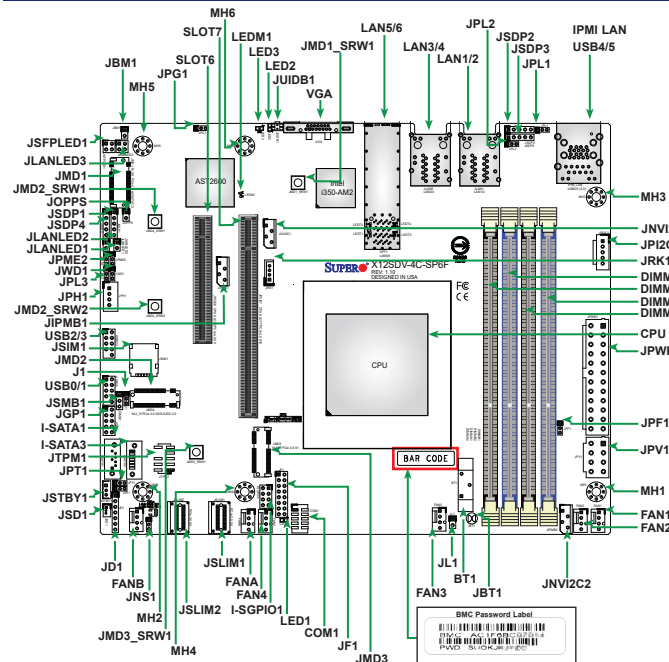

Quick Reference Table

| Jumper | Description | Default Setting |
|-----------------------------------|--------------------------------------------------------------------|-----------------------------------------------------------------------------|
| J1 | SIM Card Detection | Pins 1-2: High Active (Default) Pins 2-3: Low Active |
| JBM1 | Disable IPMI Share LAN | Pins 1-2: IPMI Share Lan Disabled Open: IPMI Share Lan Enabled (Default) |
| JBT1 | CMOS Clear | Open (Normal) |
| JNS1 | SlimSAS Interface Selection | Pins 1-2: 4X SATA Pins 2-3: PCIe x4 (Default) |
| JPF1 | Power Force On | Pins 1-2: ATX Mode (Default) Pins 2-3: Force PS-ON mode |
| JPG1 | VGA Enable/Disable | Pins 1-2 (Enabled) |
| JPL1, JPL2, JPL3 | LAN1, LAN2, LAN3/4 Enable | Pins 1-2 (Enabled) |
| JPME2 | ME Manufacturing Mode | Pins 1-2 (Normal) |
| JPT1 | Onboard TPM Enable/Disable | Pins 1-2 (Enabled) |
| JWD1 | Watchdog Timer | Pins 1-2 (Reset) |
| LED | Description | Status |
| LED1 | Power LED | Solid Green: Power On |
| LED2 | UID LED | Solid Blue: Unit Identified |
| LED3 | Overheat (OH)/Power Fail/Fan Fail LED | Solid Red: Overheat Blinking Red: Power Fail or Fan Fail |
| LEDM1 | IPMI Heartbeat LED | Blinking Green: IPMI Normal |
| Connector | Description | |
| BT1 | Onboard Battery | |
| COM1 | COM Header | |
| FAN1 - FAN4, FANA, FANB | CPU/System Fan Headers (FAN1: CPU Fan) | |
| IPMI LAN | Dedicated IPMI LAN Port | |
| I-SATA1 and I-SATA3 | Intel PCH SATA 3.0 Ports (I-SATA1: SATA DOM Power) | |
| I-SGP101 | Serial Link General Purpose I/O Header | |
| JD1 | Power LED/Speaker (Pins 1-3: Power LED, Pins 4-7: Speaker) | |
| JF1 | Front Control Panel Header | |
| JGP1 | General Purpose I/O Header | |
| JIPMB1 | 4-pin IPMI External I/O Header | |
| JL1 | Chassis Intrusion Header | |
| JLANLED1 | LAN1 Activity LED Header | |
| JLANLED2 | LAN2 Activity LED Header | |
| JLANLED3 | LAN3/4 Activity LED Header | |
| JMD1 | M.2 PCIe 3.0 x4 or SATA 3.0 Slot (M-Key 2280) | |
| Connector | Description | |
| JMD2 | M.2 PCIe 3.0 x2 or SATA 3.0 or USB 3.0 Slot (B-Key 2280/3042/3052) | |
| JMD3 | M.2 PCIe 3.0 x1 or USB 2.0 Slot (E-Key 2230) | |
| JMD1_SRW1, JMD2_SRW1/2, JMD3_SRW1 | M.2 Mounting Holes | |
| JNV12C1, JNV12C2 | Non-Volatile Memory (NVMe) I/O Headers | |
| JOPPS | Reserved for One Pulse Per Second | |
| JPH1 | 4-pin HDD Power Connector | |
| JPI2C1 | Power System Management (SMB) I/O Headers | |
| JPWR1 | 24-pin ATX Power Connector (Required) | |
| JPV1 | 8-pin CPU Power Connector (Required) | |
| JRK1 | Intel RAID Key Header | |
| JSD1 | SATA DOM Power Connector | |
| JSDP1 - JSDP4 | Reserved for time synchronization | |
| JSPLED1 | LAN5/6 Activity LED header | |
| JSIM1 | NANO SIM Slot for JMD2 | |
| JSLIM1, JSLIM2 | SlimSAS PCIe 3.0 x4 Slots | |
| J SMB1 | System Management Bus Header | |
| JSTBY1 | Standby Power Header | |
| JTPM1 | Trusted Platform Module (TPM)/Port 80 Connector | |
| JUIDB1 | Unit Identifier Switch | |
| LAN1/2, LAN3/4 | Gigabit Ethernet RJ45 Ports | |
| LAN5/6 | 25GbE SFP28 LAN Ports | |
| MH1 - MH6 | Motherboard Mounting Holes | |
| SLOT6 | CPU SLOT6 PCIe 4.0 x8 | |
| SLOT7 | CPU SLOT7 PCIe 4.0 x16 | |
| USB0/1, USB2/3 | Front Accessible USB 2.0 Headers | |
| USB4/5 | Back Panel USB 3.0 Ports | |
| VGA | VGA Port | |

System Features

| | |
|------------------------|--------------------------------------------------------------------------------------------------------------------------------------------------------------------------------------------------------------------------------------------------------|
| Processors | Supports an Intel Xeon D-1700 series processor with a thermal design power (TDP) of up to 67W Note: Please refer to the motherboard specifications pages on our website for updates to supported processors. |
| BIOS | 256Mb SPI Flash with AMI BIOS® |
| Memory | Up to 256GB of ECC and Non-ECC RDIMM/UDIMM DDR4 memory with speeds of up to 2933MHz in four memory slots |
| Storage Drive | Supports one 2.5" drive of 7mm height One M.2 PCIe 3.0 x4 or SATA 3.0 slot (M-Key 2280) populated in the connector JMD1 |
| Expansion Slots | Three connectors (JMD1 populated; JMD2 and JMD3 unpopulated): JMD1: M.2 PCIe 3.0 x4 or SATA 3.0 slot (M-Key 2280) JMD2: M.2 PCIe 3.0 x2 or SATA 3.0 or USB 3.0 Slot (B-Key 2280/3042/3052) JMD3: M.2 PCIe 3.0 x1 or USB 2.0 slot (E-Key 2230) |
| Networking | One dedicated IPMI LAN port Four Gigabit Ethernet ports Two 25G SFP28 ports |
| Motherboard | X12SDV-4C/8C-SP6F Dimensions: Mini-ITX form factor (6.7" x 6.7") (170.18mm x 170.18mm) |
| Chassis | CSE-E302iL Dimensions: 11.6" x 2.9" x 8.1" (W x H x D) (295 x 73 x 205mm) |
| System Cooling | Fanless |
| Power Supply | 180W 12V Lockable DC Power Adapter |

Rear I/O Ports

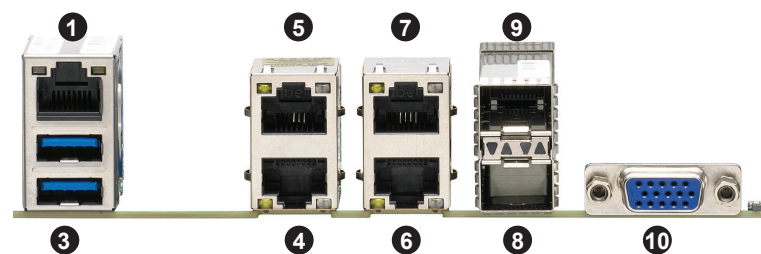

| # | Description | # | Description |
|---|-------------|----|-------------|
| 1 | IPMI LAN | 6 | RJ45 LAN3 |
| 2 | USB4 (3.0) | 7 | RJ45 LAN4 |
| 3 | USB5 (3.0) | 8 | SFP28 LAN5 |
| 4 | RJ45 LAN1 | 9 | SFP28 LAN6 |
| 5 | RJ45 LAN2 | 10 | VGA Port |

Caution

SAFETY INFORMATION
IMPORTANT: See installation instructions and safety warning before connecting system to power supply.
http://www.supermicro.com/about/policies/safety_information.cfm

WARNING:
To reduce risk of electric shock/damage to equipment, disconnect power from server by disconnecting all power cords from electrical outlets.
If any CPU socket empty, install protective plastic CPU cap.

WARNING:
Always be sure all power supplies for this system have the same power output.
If mixed power supplies are installed, the system will not operate.

For more information go to: <http://www.supermicro.com/support>

Front View & Interface

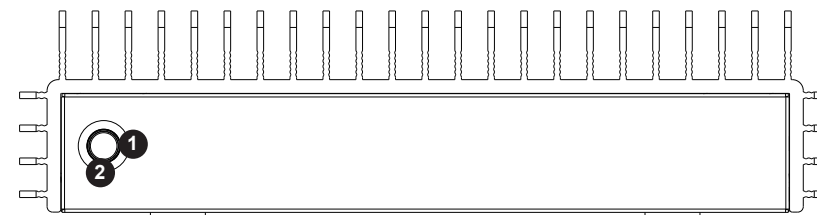

Control Panel Features

| Item | Features | Description |
|------|---------------------|---------------------------------------------------------------------------------------------------------------------------------------------------------------------------------------------------|
| 1 | Power button | The main power switch applies or removes primary power from the power supply to the server but maintains standby power. To perform most maintenance tasks, unplug the system to remove all power. |
| 2 | Power LED & HDD LED | Indicates power is being supplied to the system power supply units. This LED is illuminated when the system is operating normally. Indicates hard disk drive activity when flashing. |

Rear Features

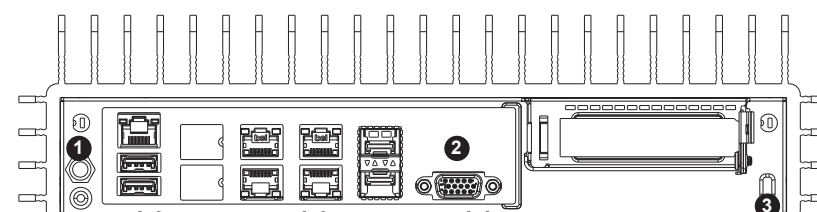

Rear Chassis Features

| Item | Features | Description |
|------|-----------------|---------------------------------------------------------------------------------------------------------------------------------------------------------------------------------------------------|
| 1 | Power input | The main power switch applies or removes primary power from the power supply to the server but maintains standby power. To perform most maintenance tasks, unplug the system to remove all power. |
| 2 | I/O ports | IPMI LAN Port, USB 3.0, GbE LAN, SFP28, VGA |
| 3 | K-slot for lock | Accepts a standard Kensington cable locking device (not included). |

Installing the Hard Drive

The drives can accommodate one fixed 2.5" storage drive of 7mm height, installed to a mounting tray inside the chassis.

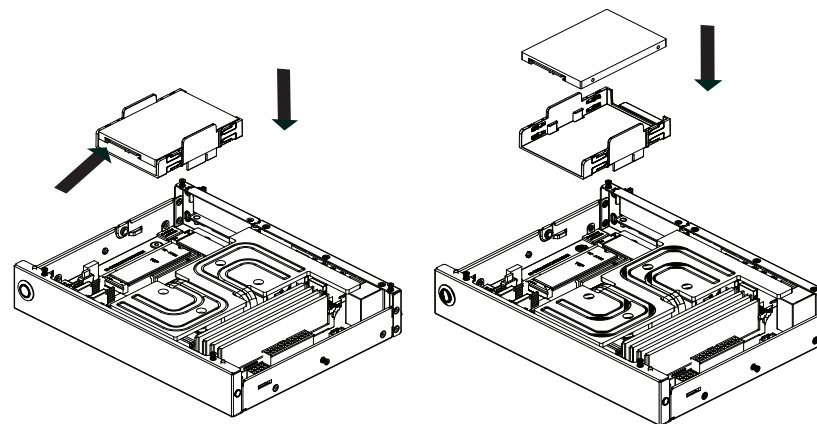

Accessing the System

Removing the Chassis Cover Removing the Bottom Cover

1. Power down the system.
2. Remove the six screws that hold the cover in place.
3. Lift the cover up and off the chassis.

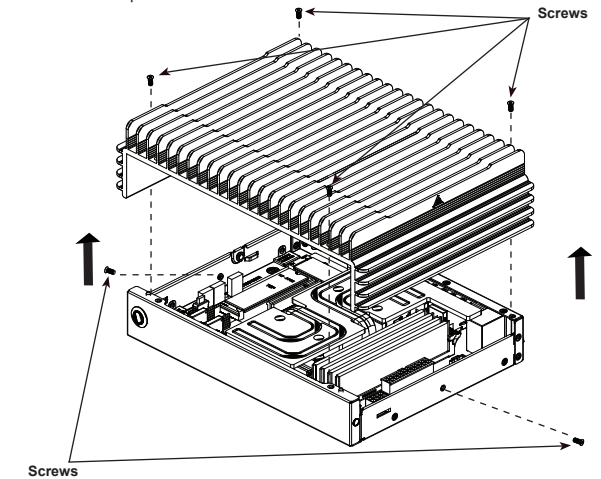

Mounting Bracket and Wall Mounting

STEP 1: Installing the Mounting Bracket

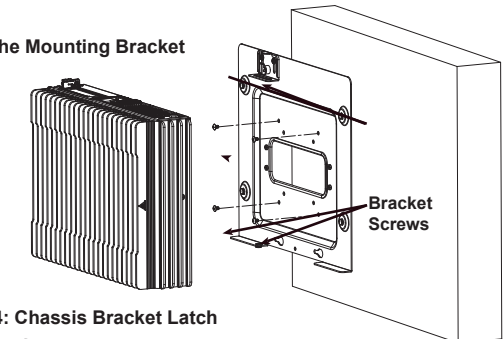

STEP 2 & 4: Chassis Bracket Latch

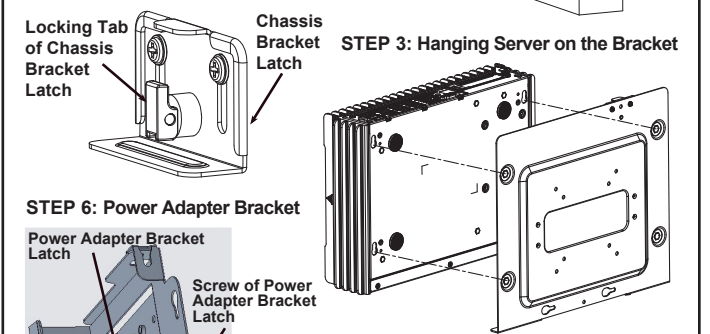

STEP 6: Power Adapter Bracket

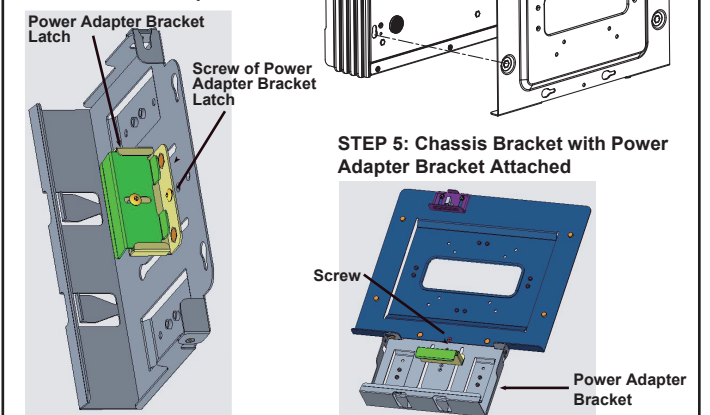

STEP 5: Chassis Bracket with Power Adapter Bracket Attached

1. Install the mounting bracket to the wall by using four screws.
2. Unlock the latch on the top of chassis bracket and slide the latch upward.
3. Hang the server system on the mounting bracket hooking the four keyholes on four knobs of the bracket.
4. Secure the server system to the bracket by sliding the latch back down and flipping tab to lock.
5. Additional power adapter bracket on the bottom of the chassis bracket.
6. Secure the power adapter by lowering the latch and tightening the screw.

