

# SUPERMICR SuperServer 111E-F(D)WTR Quick Reference Guide

## Board Layout

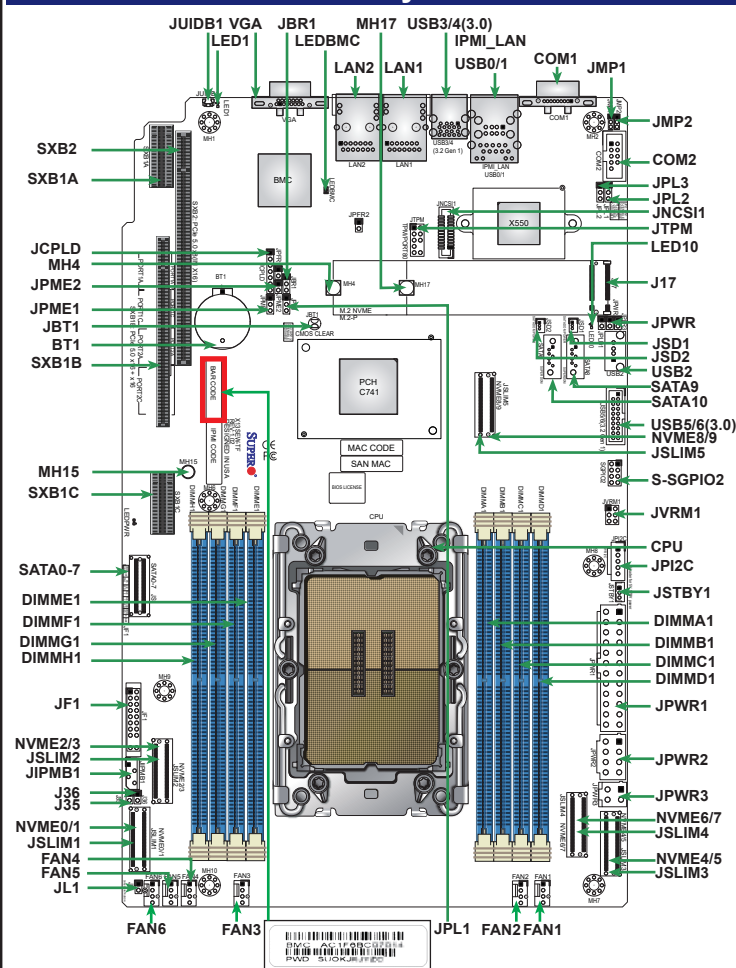

## Front View & Interface

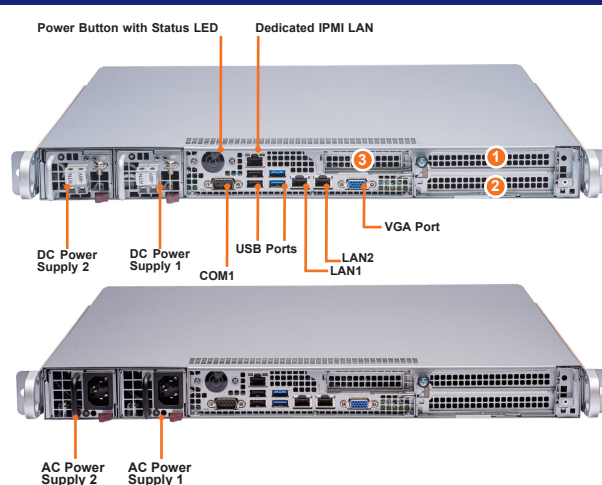

System Features: Front	
Power Supplies	Two redundant power supply modules: PWS1 on the right, PWS2 on the left.
Power Button with Status LED	The main power switch applies or removes primary power from the power supply to the server but maintains standby power. To perform most maintenance tasks, unplug the system to remove all power. This LED is illuminated when the system is operating normally. Indicates hard disk drive activity when flashing.
COM Port	Serial port
USB	Two USB 3.2 Gen 1 ports and two USB 2.0 ports
Dedicated BMC LAN	Accepts an RJ45 type cable and has two LED indicators
LAN	Two LAN ports Speed indicator is green when the connection is 1Gb/s. Speed indicator is orange when the connection is 10 Gb/s.
VGA	Video port

Expansion Slot Locations	
1	PCIe 5.0 x16 low-profile slot for PCIe expansion card
2	PCIe 5.0 x16 Full-height full-length slot for PCIe expansion card
3	PCIe 5.0 x16 Full-height full-length slot for PCIe expansion card

## Removing the Chassis Cover and Hard Drive Installation

### Removing the Top Cover

1. Remove one screw and loosen the thumbscrew that holds the top cover in place.
2. Slide the top cover towards the back, then lift the top cover up.

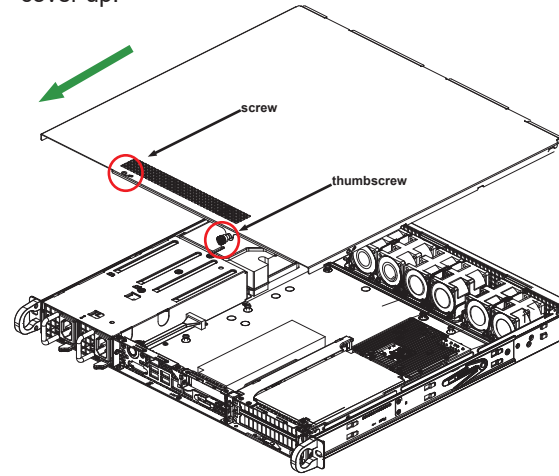

### Installing 2.5" Drives

Remove power and remove the chassis cover. Then remove the drive brackets from the chassis. Insert the drive into the drive brackets and secure the drive to the bracket with screws, as shown below. Connect the drive cables to the motherboard and the power supply, reinstall the chassis cover, reconnect the power cord, and power up the system.

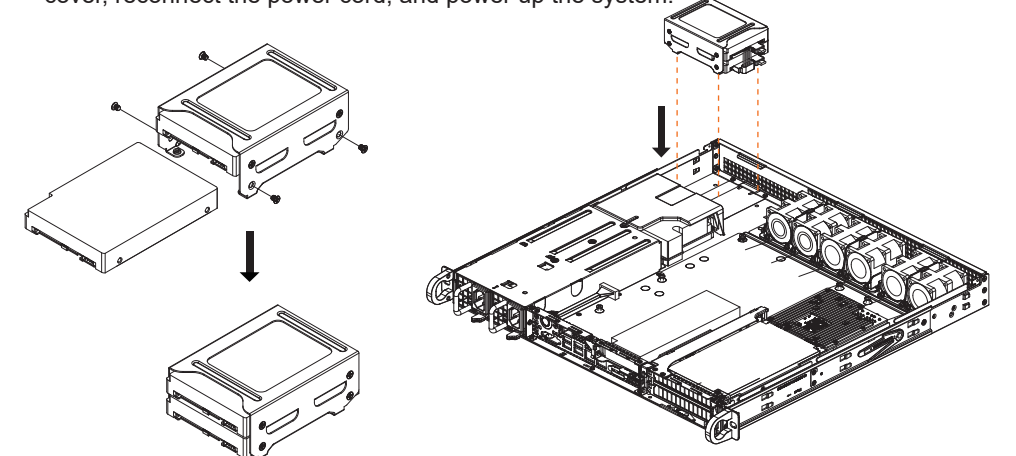

## Memory

### DIMM Installation

1. Insert the desired number of DIMMs into the memory slots in the following order: DIMMA1, DIMMD1, DIMMB1, DIMME1, DIMMC1, DIMMF1. For the best performance, please use the memory modules of the same type and speed.
2. Push the release tabs outwards on both ends of the DIMM slot to unlock it.
3. Align the key of the DIMM module with the receptive point on the memory slot.
4. Align the notches on both ends of the module against the receptive points on the ends of the slot.
5. Press the notches on both ends of the module straight down into the slot until the module snaps into place.
6. Press the release tabs to the lock positions to secure the DIMM module into the slot.

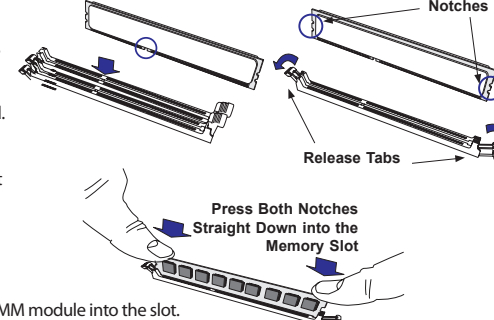

## Caution and Product Resources

**SAFETY INFORMATION:**  
IMPORTANT: See installation instructions and safety warning before connecting system to power supply.  
[http://www.supermicro.com/about/policies/safety\\_information.cfm](http://www.supermicro.com/about/policies/safety_information.cfm)

**CAUTION:**  
Always be sure all power supplies for this system have the same power output. If mixed power supplies are installed, the system will not operate.

**WARNING:**  
To reduce risk of electric shock/damage to equipment, disconnect power from server by disconnecting all power cords from electrical outlets. If any CPU socket empty, install protective plastic CPU cap.

**CAUTION:**  
This unit has redundant power sources. Please disconnect all the power cords before servicing.

## CPU Installation, Supports a single Intel Xeon Sapphire Rapids Scalable Processor (LGA 4677)

Item	Description	Default Setting
<b>Jumper</b>		
JBR1	BIOS Recovery	Pins 1-2 (Normal)
JBT1	CMOS Clear	Open (Normal)
JPL1	I210 LAN1 Enable/Disable	Pins 1-2 (Enabled)
JPL2	I210 LAN2 Enable/Disable	Pins 1-2 (Enabled)
JPL3	X550 LAN1 and LAN2 Enable/Disable	Pins 1-2 (Enabled)
JPME1	ME Recovery	Pins 1-2 (Normal)
JVRM1	VRM SMB Clock (to BMC) VRM SMB DATA (to BMC)	Pins 1-2 (Normal) Pins 3-4 (Normal)
<b>LED</b>	<b>Description</b>	<b>Status</b>
LED1	UID LED	Solid Blue: Unit Identified
LED10	M.2 LED	Blinking: Device Working
LEDBMC	BMC Heartbeat	Blinking Green: Device Working
LEDPWR	Onboard Power LED	Solid Green: Power On
<b>Connector</b>	<b>Description</b>	
BT1	Onboard Battery	
COM1, COM2	COM Port/COM Header	
FAN1-FAN6	CPU/System Fan Headers	
IPMI LAN	Dedicated IPMI LAN Port	
J17	M.2 Connector (supports M-Key 2280 and 22110)	
JCPD	CPLD Programming Header	
JF1	Front Control Panel Header	
JIPMB1	System Management Bus Header (for IPMI only)	
JL1	Chassis Intrusion Header	
JNCS1	NC-SI Port Selection	
JPI2C	Power Supply SMBus PC Header	
JPWR1	24-pin ATX Power Connector (Required)	
JPWR2-JPWR3	12V 8-pin and 4-pin CPU Power Connectors (To provide alternative power for special enclosure when the 24-pin ATX power is not in use.)	
JSD1-JSD2	SATA DOM Power Connectors	
JSLIM1-JSLIM5	Backplane NVMe M.2 Connector (each connector supports two PCIe 5.0 x8 devices)	
JSTBY1	Standby Power Header	
JTPM	Trusted Platform Module/Port 80 Connector	
JUIDB1	Unit Identifier Switch	
LAN1-LAN2	LAN (RJ45) Ports	
SATA0-7 (Slimline SAS)	Intel PCH SATA 3.0 Ports	
SATA8-SATA9	SATA 3.0 Ports with SuperDOM Power	
SXB1A, SXB1B, SXB1C	PCIe 5.0 x16 + x16 Supermicro Proprietary WIO Left Add-on Card Slots	
SXB2	PCIe 5.0 x8 (In x16) Supermicro Proprietary WIO Right Add-on Card Slot	
SGPIO2	Serial Link General Purpose I/O Header	
USB0/1	Back Panel USB 2.0 Ports	
USB2	Front Access USB 2.0 TypeA Header	
USB3/4	Back Panel USB 3.2 Gen 1 Ports	
USB5/6	Front Access USB 3.2 Gen 1 Headers	
VGA	VGA Port	

### A. Creating the Intel Sapphire Rapids CPU Carrier Assembly

1. Locate small gold triangle (Pin 1) on processor and corresponding hollowed triangle on carrier.
2. Using the triangles as a guide, carefully align and place Point A of the processor into the carrier. Gently snap into place to fasten onto Point B.

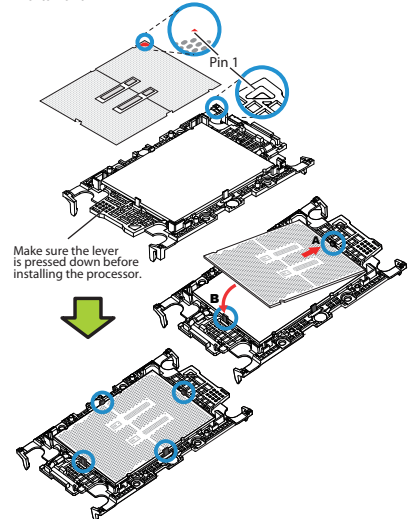

### B. Assembling the Processor Heatsink Module (PHM)

1. If this is a new heatsink, the thermal grease has been preapplied. Otherwise, apply the proper amount of thermal grease.
2. Hold the processor carrier assembly so the processor's gold contacts are facing up, then align the holes of the processor carrier assembly with the holes on the heatsink. Press the processor carrier assembly down until it snaps into place. The plastic clips of the processor carrier assembly will lock at the four corners.
3. Examine all corners to ensure that the plastic clips on the processor carrier assembly are firmly attached to the heatsink.

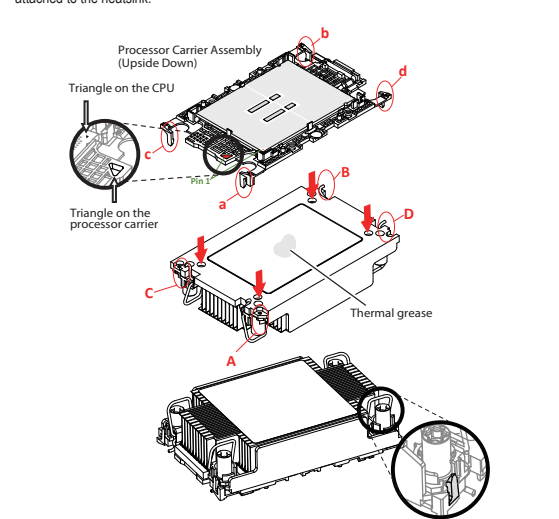

### C. Preparing the CPU Socket for Installation

Gently pull off the plastic protective cover by one corner to remove it from the CPU socket.

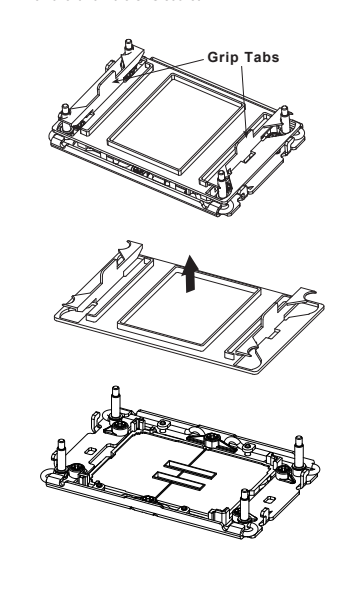

### D. Installing the Process Heatsink Module

1. Locate four threaded fasteners (a, b, c, d) on the CPU socket.

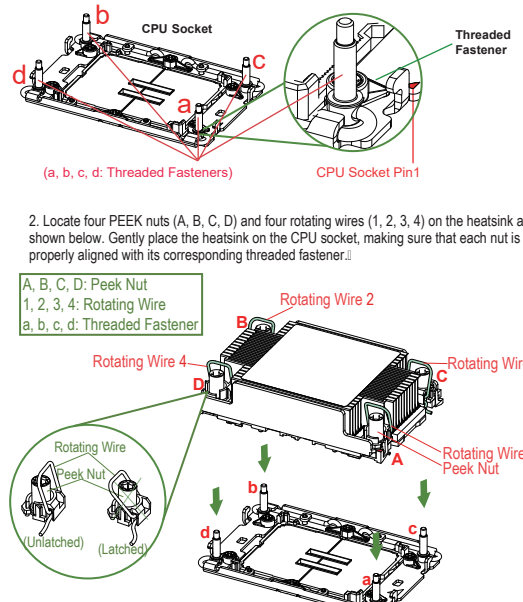

3. Press all four rotating wires outward to latch the PHM onto the CPU socket.

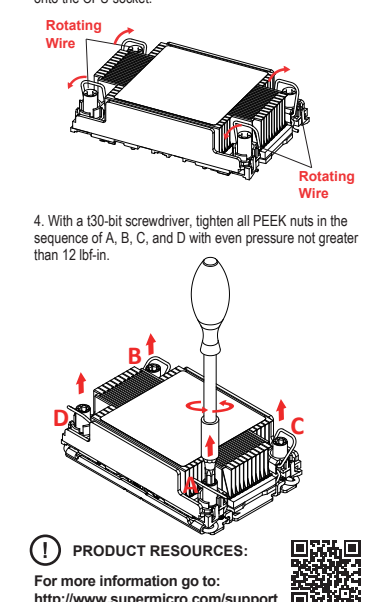

Check each corner to ensure that the processor carrier is firmly attached to the heatsink.

**PRODUCT RESOURCES:**  
For more information go to:  
<http://www.supermicro.com/support>