

# SUPERMICR<sup>®</sup> SuperServer 111R-M Quick Reference Guide

## Board Layout

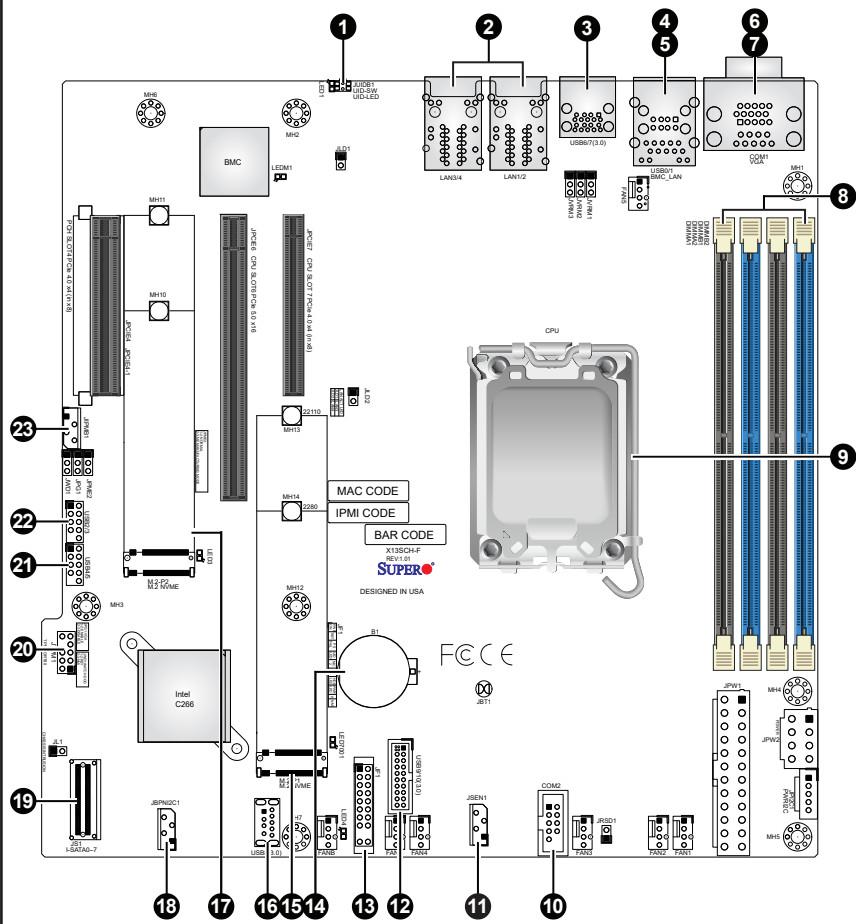

Item	Description
1	Button for UID LED and BMC Reset
2	Two 1GbE LAN Ports
3	USB 3.2 Gen 1 Ports
4	Dedicated BMC LAN Port
5	USB 2.0 Ports
6	COM Port (Serial Port)
7	VGA Port
8	DIMM A1-B2 Slots
9	CPU
10	COM Port Header (Serial Port)
11	Inlet Sensor Header
12	USB 3.2 Gen 1 Header

Item	Description
13	Front Control Panel Header
14	Onboard CMOS Battery
15	M.2 PCIe 4.0 Interface P1 (PCH)
16	USB 3.2 Gen 1 Type-A Port
17	M.2 PCIe 4.0 Interface P2 (PCH)
18	4-pin BMC External I2C Header for BPN
19	I-SATA 0-7: SlimSAS SATA 3.0 Ports
20	TPM Header
21	USB4/5: USB 2.0 Headers
22	USB2/3: USB 2.0 Headers
23	4-pin BMC External I2C Header for AOC

## Front View and Features

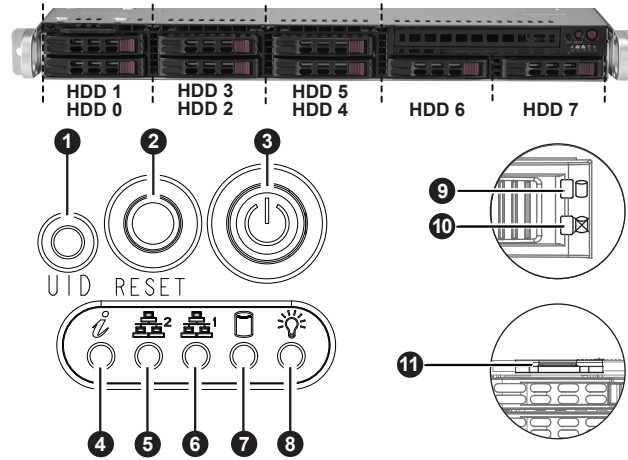

### Control Panel Features

Item	Description
1	UID Button
2	Reset Button
3	Power Button
4	Information LED
5	NIC2 LED
6	NIC1 LED
7	HDD LED
8	Power LED
9	Drive Activity LED
10	Drive Status LED
11	Service/Asset Tag (pull-out identifier with BMC_ADMIN default password underneath)

## Rear View and Features

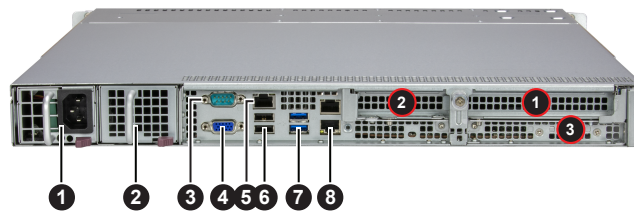

Item	Description
1	Single 600W Titanium-Level Power Supply (Optional) Redundant Power
2	Serial Port
3	VGA Port
4	Dedicated BMC LAN Port
5	2 USB 2.0 Ports
6	2 USB 3.2 Gen 1 Ports
7	2 RJ45 1GbE Ports

Item	Slot Description
1	PCIe 5.0 x16 or PCIe 5.0 x8 FHHL
2	PCIe 5.0 x0 or PCIe 5.0 x8 LP
3	Dedicated Internal HBA Slot

## BMC Password Label

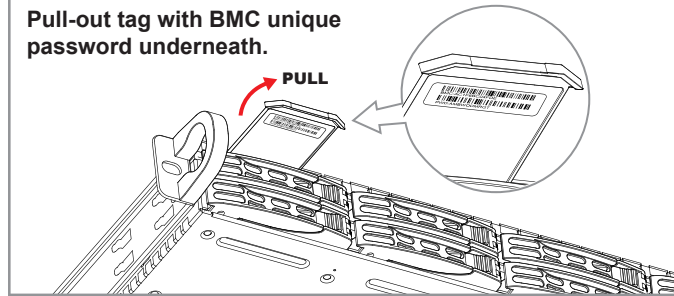

Each system comes with a unique default password for the ADMIN user. This can be found on a sticker on the motherboard and a sticker underneath the service tag on chassis. If necessary, the password can be reset by the Supermicro IPMICFG tool.

For more information, please visit <https://www.supermicro.com/en/solutions/management-software/bmc-resources>

## Memory

### DIMM Installation

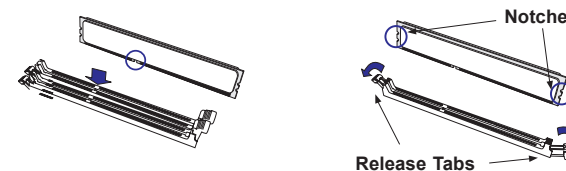

When installing memory modules, the DIMM slots should be populated in the following order: DIMMB2 / DIMMA2 / DIMMB1 / DIMMA1.

- Always use DDR5 DIMM modules of the same type, size, and speed.
- Mixed DIMM speeds can be installed. However, all DIMMs will run at the speed of the slowest DIMM.
- The motherboard will support odd-numbered modules (1 or 3 modules) installed. However, to achieve the best memory performance, fully populate the motherboard with validated memory modules.

### 1 CPU, 4 DIMM Slots

Number of DIMMs	Memory Population Sequence
1	DIMMB2
2	DIMMB2 / DIMMA2
3	(Unbalanced; not recommended)
4	DIMMB2 / DIMMA2 / DIMMB1 / DIMMA1

## CPU Installation and Removal

Supports a single Intel Xeon E-2400 or Pentium Processor (LGA 1700)

### Installing the LGA1700 Processor

1. Press the load lever down to release the load plate from its locking position.
2. Gently lift the load lever to open the load plate. Remove the plastic protective cover. Do not touch the CPU socket contacts.
3. Align the Pin 1 triangle on the CPU with the Pin 1 triangle on the socket.
4. Carefully lower the CPU straight down into the socket. Inspect the four corners to make sure that the CPU is properly installed. (You can only install the CPU in one direction.)

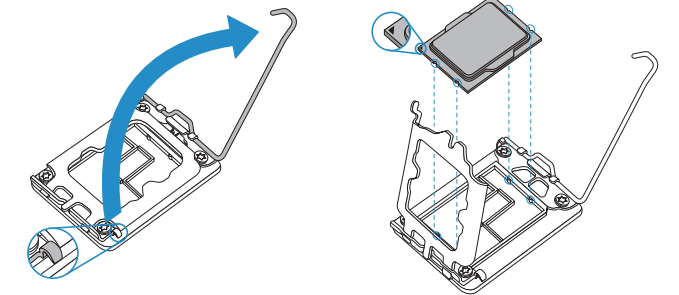

5. Close the load plate, then gently push down the load lever into its locking position.

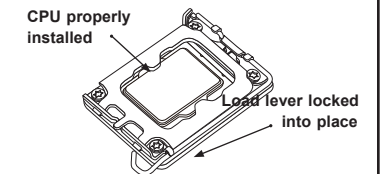

### Installing a CPU Heatsink

1. Apply thermal grease to the heatsink or the CPU.
2. Align the four holes of the heatsink with the four mounting holes on the motherboard.
3. With a Phillips screwdriver, gradually tighten screws in the order of #1, #2, #3, #4, ensuring even pressure.

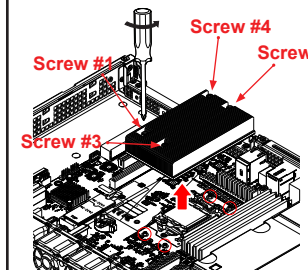
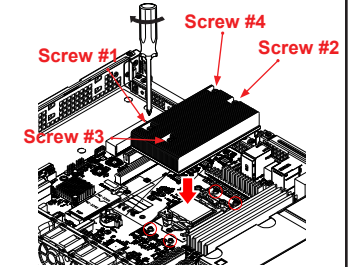

### Removing the Heatsink

1. Unplug the power connector from the power supply.
2. Unscrew the heatsink screws in the sequence of #1, #2, #3, #4.
3. Gently lift the heatsink up and remove it from the CPU.

## Caution

**SAFETY INFORMATION**  
IMPORTANT: See installation instructions and safety warning before connecting system to power supply.  
[http://www.supermicro.com/about/policies/safety\\_information.cfm](http://www.supermicro.com/about/policies/safety_information.cfm)

**WARNING:**  
To reduce risk of electric shock/damage to equipment, disconnect power from server by disconnecting all power cords from electrical outlets. If any CPU socket empty, install protective plastic CPU cap

**WARNING:**  
Always be sure all power supplies for this system have the same power output. If mixed power supplies are installed, the system will not operate.

For more information go to : <http://www.supermicro.com/support>

