

SUPERMICR SuperServer 112B-WR Quick Reference Guide

Board Layout

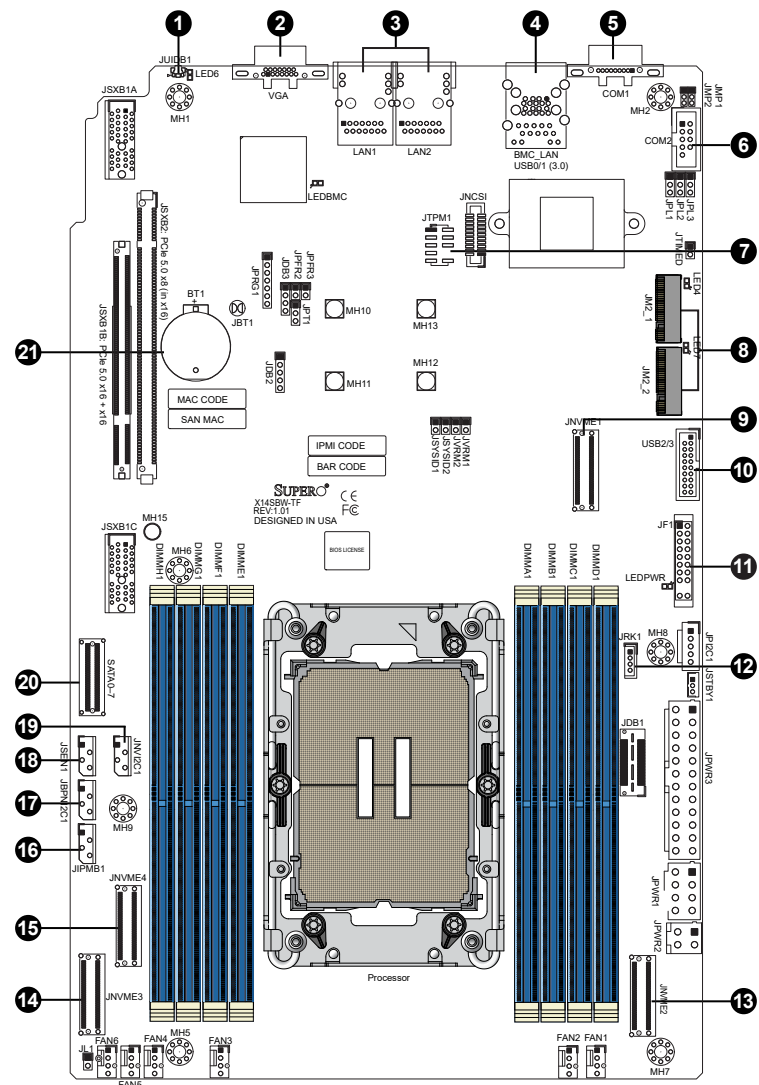

Item	Description	Item	Description
1	UID Button (Unit Identifier Button)	11	JF1: Front Control Panel Header
2	VGA Port	12	JRK1: Intel VROC RAID Key Header
3	Two 1GbE LAN Ports	13	JNVME2: PCIe 5.0 x8 MCIO Connector
4	USB 3.2 Gen 1 Ports / Dedicated LAN for IPMI	14	JNVME3: PCIe 5.0 x8 MCIO Connector for IPMI
5	COM Port (Serial Port)	15	JNVME4: PCIe 5.0 x8 MCIO Connector
6	COM Port Header (Serial Port)	16	JIPMB1: System Management Bus Header (for IPMI only)
7	JTPM1: TPM Header	17	JBPNI2C1: BPN I2C Header
8	JM2_1/JM2_2: M.2 PCIe 5.0 Interface (M-key 2280 and 22110)	18	JSEN1: Inlet Sensor Header
9	JNVME1: PCIe 5.0 x8 MCIO Connector	19	JNVI2C1: NVME I2C Header
10	USB2/3: USB 3.2 Gen1 Header	20	SATA 0-7: SlimSAS SATA 3.0 Ports
		21	Onboard CMOS Battery

Front View and Features

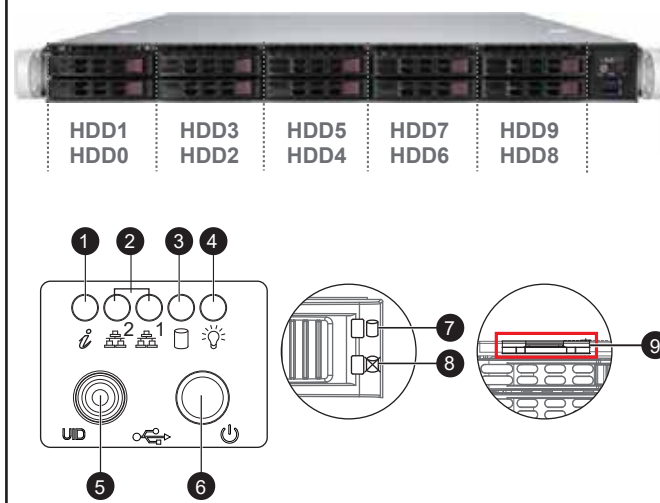

Item	Description
1	Universal Information LED
2	NIC1 (Right) and NIC2 (Left) LED
3	HDD LED
4	Power LED
5	UID Button
6	Power Button
7	Drive Activity LED
8	Drive Status LED
9	Service/Asset Tag (pull-out identifier with BMC ADMIN default password underneath)

Rear View and Features

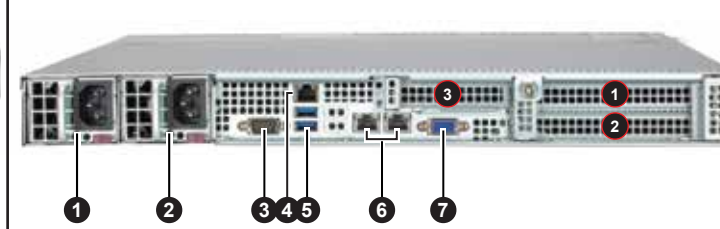

Item	Description	Item	Slot Description
1	Power Supply 1	1	PCIe 5.0 x16 Slot (FH, 12.3" L)
2	Power Supply 2	2	PCIe 5.0 x16 Slot (FH, 12.3" L)
3	Serial Port	3	PCIe 5.0 x8 (in x16) Slot (LP)
4	Dedicated BMC LAN Port		
5	Two USB 3.2 Gen1 Ports		
6	LAN 1 (left) and LAN 2 (right) Ports		
7	VGA Port		

Caution

SAFETY INFORMATION
 IMPORTANT: See installation instructions and safety warning before connecting system to power supply.
https://www.supermicro.com/about/policies/safety_information.cfm

WARNING
 To reduce risk of electric shock/damage to equipment, disconnect power from server by disconnecting all power cords from electrical outlets.
 If any CPU socket is empty, install protective plastic CPU cap.

CAUTION
 Always be sure all power supplies for this system have the same power output. If mixed power supplies are installed, the system will not operate.
 For more information, go to <https://www.supermicro.com/support>

Memory

DIMM Installation

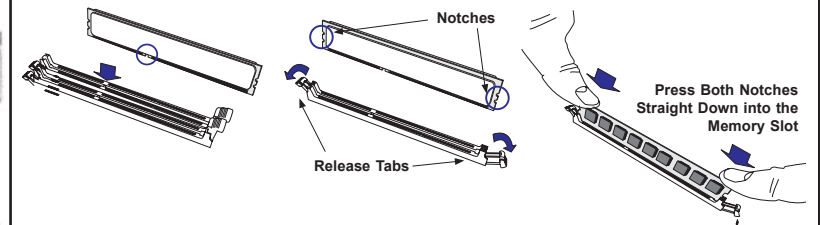

Type	Channel							
	H1	G1	F1	E1	CPU			
					A1	B1	C1	D1
1 DIMM					V			
4 DIMMs		V		V	V		V	
8 DIMMs	V	V	V	V	V	V	V	V

Note: Please refer to user manual for memory module [rank] and [DRAM density] requirements when using Intel® Xeon® 6 CPU.

BMC Password Label

Pull-out tag with BMC unique password and Serial Number Label underneath.

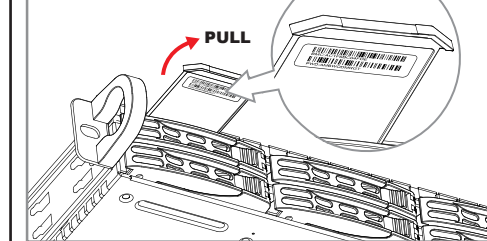

Each system comes with a unique default password for the ADMIN user. This can be found on a sticker on the motherboard and a sticker underneath the service tag on chassis. If necessary, the password can be reset by the Supermicro IPMICFG tool.

For more information, please visit <https://www.supermicro.com/en/solutions/management-software/bmc-resources>

CPU Installation, supporting a single Intel® Xeon® 6 Processor (LGA 4710)

A. Creating the Intel Xeon 6 CPU Carrier Assembly

1. Locate small gold triangle (Pin 1) on processor and corresponding hollowed triangle on carrier.
2. Using the triangles as a guide, carefully align and place Point A of the processor into the carrier. Gently snap into place to fasten onto Point B.

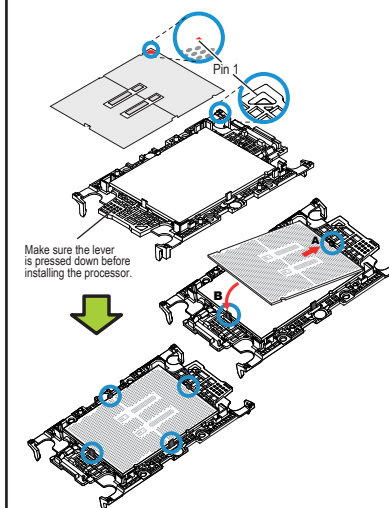

B. Assembling the Processor Heatsink Module (PHM)

1. If this is a new heatsink, the thermal grease has been preapplied. Otherwise, apply the proper amount of thermal grease.
2. Hold the processor carrier assembly so the processor's gold contacts are facing up, then align the holes of the processor carrier assembly with the holes on the heatsink. Press the processor carrier assembly down until it snaps into place. The plastic clips of the processor carrier assembly will lock at the four corners.
3. Examine all corners to ensure that the plastic clips on the processor carrier assembly are firmly attached to the heatsink.

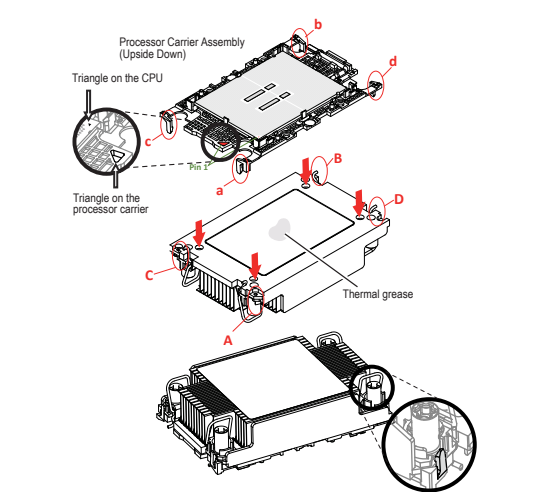

Check each corner to ensure that the processor carrier is firmly attached to the heatsink.

C. Preparing the CPU Socket for Installation

1. Gently pull off the plastic protective cover by one corner to remove it from the CPU socket.

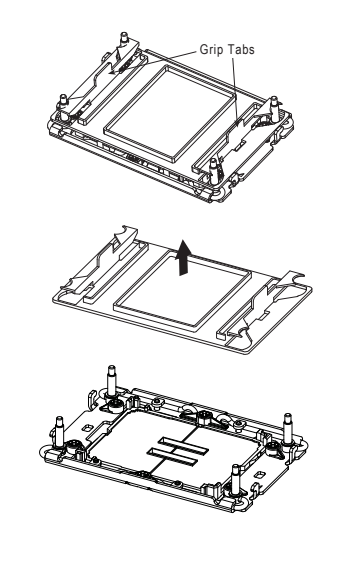

D. Installing the Process Heatsink Module

1. Locate four threaded fasteners (a, b, c, d) on the CPU socket.

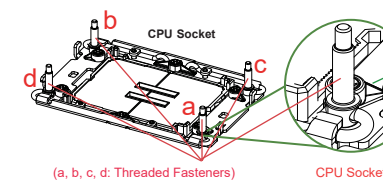

2. Locate four PEEK nuts (A, B, C, D) and four rotating wires (1, 2, 3, 4) on the heatsink as shown below. Gently place the heatsink on the CPU socket, making sure that each nut is properly aligned with its corresponding threaded fastener.

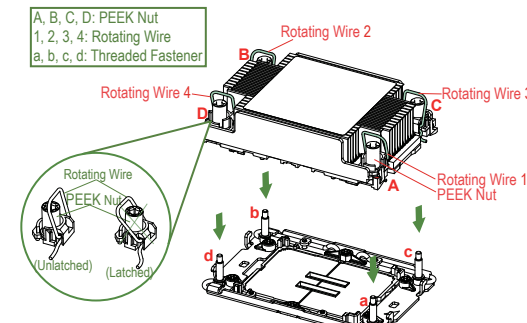

3. Press all four rotating wires outward to latch the PHM onto the CPU socket.

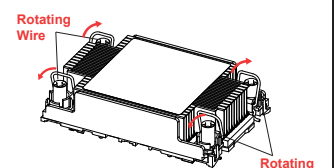

4. With a 130-bit screwdriver, tighten all PEEK nuts in the sequence of A, B, C, and D with even pressure not greater than 8 in-lb (0.904 N-m).

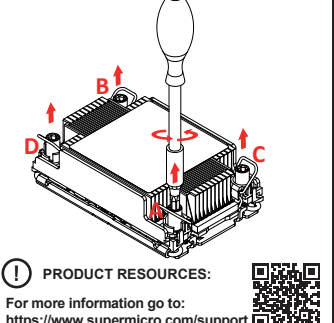

PRODUCT RESOURCES:
 For more information go to: <https://www.supermicro.com/support>

