

Board Layout

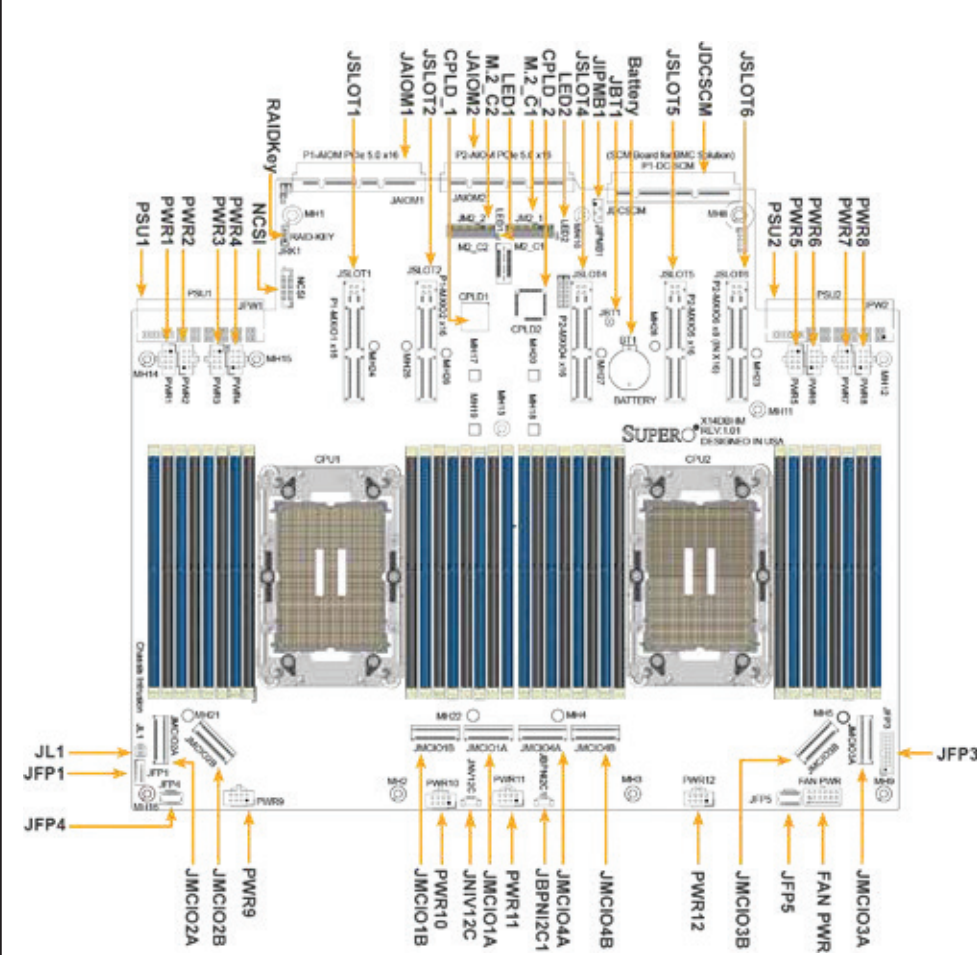

Connector	Description
BT1	Onboard CMOS Battery
CPLD1/CPLD2	Complex Programmable Logic Devices
FAN_PWR	Cooling Fan Power Connector
JAIOM1	Supermicro Advanced Input/Output Module (AIOM) Connector for Rear I/O Support (P1-AIOM PCIe 5.0 x16)
JAIOM2	Supermicro Advanced Input/Output Module (AIOM) Connector for Rear I/O Support (P2-AIOM PCIe 5.0 x16)
JBP1	Backplane I/O NVMe Header
JIPMB1	4-Pin BMC External I°C Header
JFP1	Front Control Panel Header
JFP3	Front Control Panel Header 2
JFP4-JFP5	Front Control Panel Header for Intel (optional)
JL1	Chassis Intrusion Header
JMCIO1A/1B	MCIO PCIe 5.0 x8 Connectors (P1-PE4 7-0/P1-PE4 15-8)
JMCIO2A/2B	MCIO PCIe 5.0 x8 Connectors (P1-PE5 0-7/P1-PE4 8-15)
JMCIO3A/3B	MCIO PCIe 5.0 x8 Connectors (P2-PE4 15-8/P2-PE4 7-0)
JMCIO4A/4B	MCIO PCIe 5.0 x8 Connectors (P2-PE5 0-7/P2-PE5 8-15)
JNCS1	Network Controller Sideband Interface (NC-SI) Connector
JNVPC1	Backplane NVMe VPP Header
JRK1	Intel VROC RAID Key Header
JSL0T1 (P1-MXIO1)	Multi-Trak I/O PCIe 5.0 x16 Slot
JSL0T2 (P1-MXIO2)	Multi-Trak I/O PCIe 5.0 x16 Slot
JSL0T4 (P2-MXIO4)	Multi-Trak I/O PCIe 5.0 x16 Slot
JSL0T5 (P2-MXIO5)	Multi-Trak I/O PCIe 5.0 x16 Slot
JSL0T6 (P2-MXIO6)	Multi-Trak I/O PCIe 5.0 x16 Slot
P1-DC-SCM (JDCSCM)	DC-SCM Board connector for BMC solution (PN: AOM-SCM-DCX6)
PSU1/PSU2 (JPW1/2)	Power Supply Unit1/Unit2 Connectors
PWR1-PWR8	8-Pin +12V Power Connectors
PWR9-PWR12	8-Pin +12V Backplane/GPU Power Connectors
M2_C1/M2_C2 (JM2_C1/C2)	M.2 M-key PCIe 5.0 x2 Slots C1/C2
MH1/MH8	Motherboard Guide Pins
MH2/MH3/MH9-16	Motherboard Mounting Holes
MH23-MH28	Riser Card Guide Pins
MH4/MH5/MH21/MH22	Processor Heatsink Module (PHM) Mounting Holes
MH17-MH20	M.2 M-key Mounting Holes

Memory

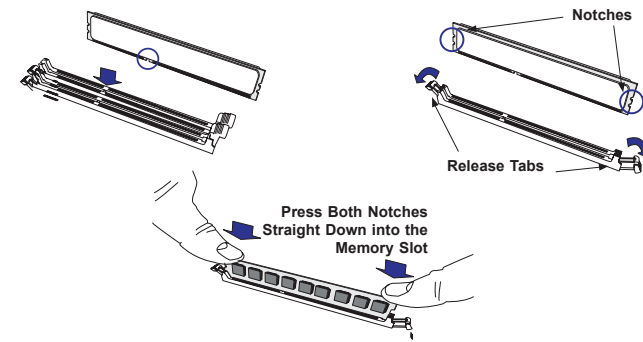

1. Insert the desired number of DIMMS into the memory slots in the order as defined in the system manual. For best performance, please use the memory modules of the same type and speed.
2. Push the release tabs outward on both ends of the DIMM slot to unlock it.
3. Align the key of the DIMM module with the receptive point on the memory slot.
4. Align the notches on both ends of the module against the receptive points at the ends of the slot.
5. Press the notches on both ends of the module straight down into the slot until the module snaps into place.
6. Press the release tabs into the lock positions to secure the DIMM module into the slot.

BMC Password Label

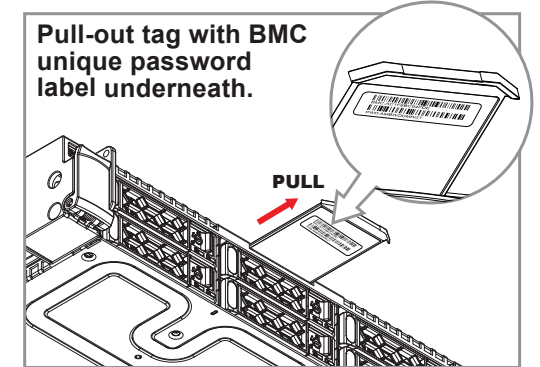

Each system comes with a unique default password or the ADMIN user. This can be found on a sticker on the motherboard and a sticker underneath the service tag on chassis. If necessary, the password can be reset by the Supermicro IPMICFG tool.

For more information, please visit <https://www.supermicro.com/en/solutions/management-software/bmc-resources>

Rear View and Features

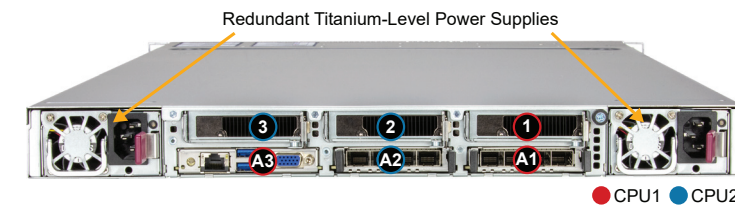

Slot Description	Slot Description
2 PCIe 5.0 x16 LP	1 PCIe 5.0 x16 LP
3 PCIe 5.0 x8 LP	A1 PCIe 5.0 x16 AIOM (OCP 3.0)
A2 PCIe 5.0 x16 AIOM (OCP 3.0)	A3 DC-SCM

Caution

SAFETY INFORMATION:
IMPORTANT: See installation instructions and safety warning before connecting system to power supply. http://www.supermicro.com/about/policies/safety_information.cfm

WARNING:
To reduce risk of electric shock/damage to equipment, disconnect power from server by disconnecting all power cords from electrical outlets. If any CPU socket empty, install protective plastic CPU cap.

CAUTION:
Always be sure all power supplies for this system have the same power output. If mixed power supplies are installed, the system will not operate.

CAUTION:
This unit has redundant power sources. Please disconnect all the power cords before servicing.

Resources

PRODUCT RESOURCES:
For more information go to: <http://www.supermicro.com/support>



Front View and Features



Drive Bay	Description
0 - 11	12 Hot-Swappable 2.5" NVMe*/SATA*/SAS* Hybrid Drive Bays

*NVMe/SATA/SAS support requires additional parts from optional parts list.

CPU Installation

A. Creating the Intel Sapphire Rapids CPU Carrier Assembly

1. Locate small gold triangle (Pin 1) on processor and corresponding hollowed triangle on carrier.
2. Using the triangles as a guide, carefully align and place Point A of the processor into the carrier. Gently snap into place to fasten onto Point B.

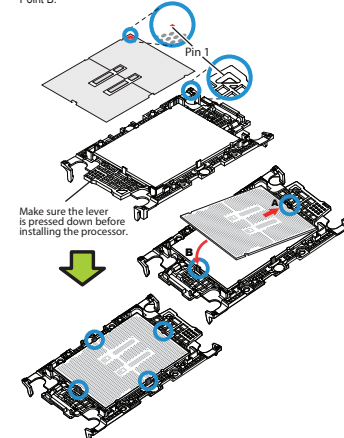

B. Assembling the Processor Heatsink Module (PHM)

1. If this is a new heatsink, the thermal grease has been preapplied. Otherwise, apply the proper amount of thermal grease.
2. Hold the processor carrier assembly so the processor's gold contacts are facing up, then align the holes of the processor carrier assembly with the holes on the heatsink. Press the processor carrier assembly down until it snaps into place. The plastic clips of the processor carrier assembly will lock at the four corners.
3. Examine all corners to ensure that the plastic clips on the processor carrier assembly are firmly attached to the heatsink.

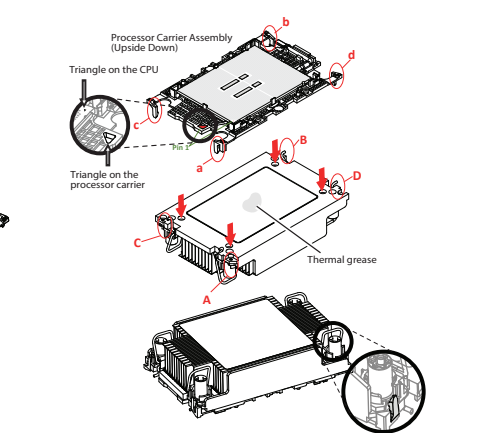

C. Preparing the CPU Socket for Installation

1. Gently pull off the plastic protective cover by one corner to remove it from the CPU socket.

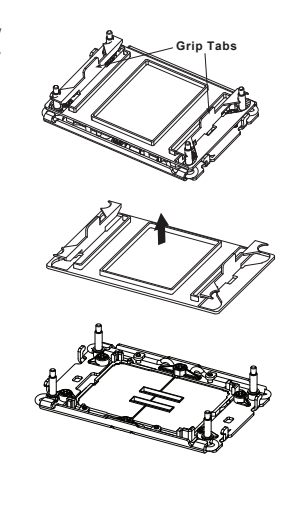

D. Installing the Process Heatsink Module

1. Locate four threaded fasteners (a, b, c, d) on the CPU socket.

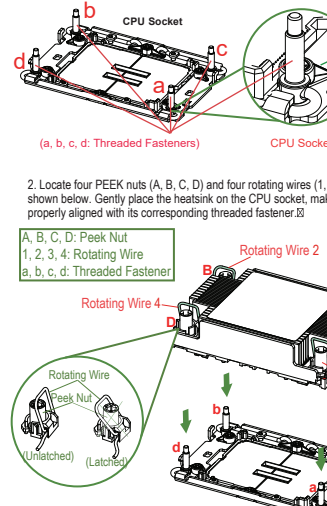

3. Press all four rotating wires outward to latch the PHM onto the CPU socket.

