

SUPERMICR SuperServer 220U-TNR Quick Reference Guide

Board Layout

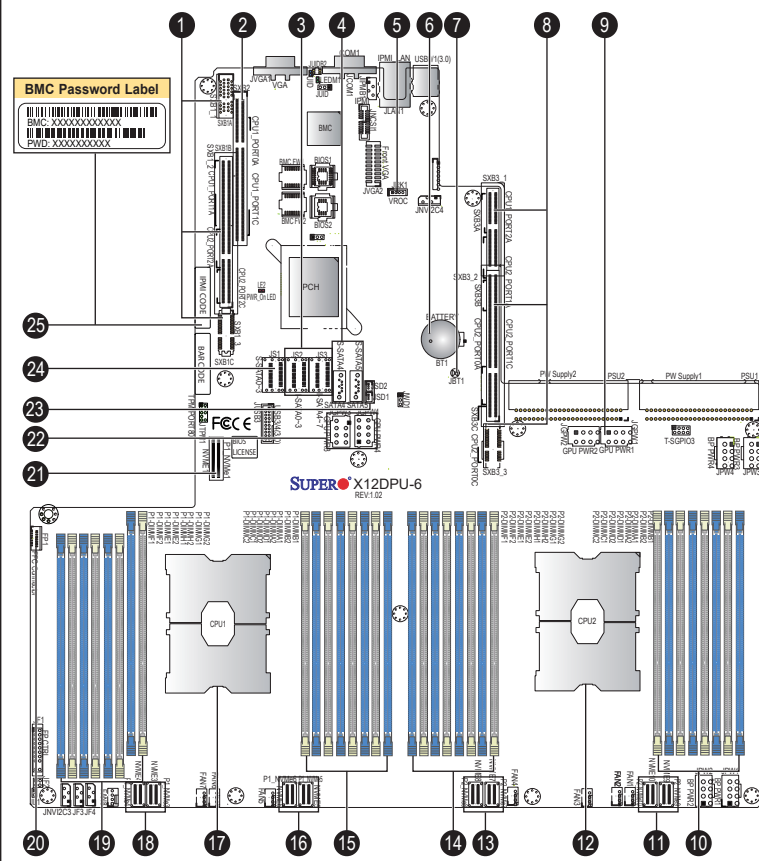

No.	Description
1	SXB1A/1B/1C: Proprietary PCI-e Slot used for WIO-Left Devices (x16 From CPU1, x16 From CPU2)
2	SXB2: Proprietary PCI-e Slot for WIO-Right Devices (x16 From CPU1)
3	I-SATA0~3, I-SATA4~7: SATA 3.0 Ports (Intel PCH)
4	S-SATA 4, 5: SATA 3.0 Ports (Intel SCU)
5	VROC : Intel VROC Key Header for NVMe RAID
6	BT1 : Onboard CMOS battery
7	JBT1: CMOS Clear
8	SXB3A/3B/3C: Proprietary PCI-e Slot for Ultra Riser Devices (x8 From CPU1, x32 From CPU2)
9	JGPW1/JGPW2: GPU 8-pin power connectors
10	P2-DIMMA1/B1/C1/D1(Blue) and P2-DIMMA2/B2/C2/D2(Black)
11	P2-NVMe 9/10: PCI-E 4.0 x8 NVMe ports
12	CPU2
13	P2-NVMe 7/8: PCI-E 4.0 x8 NVMe ports
14	P2-DIMMG2/G1/H2/H1(Blue) and P2-DIMME2/E1/F2/F1(Black)
15	P1-DIMMB1/B2/A1/A2(Blue) and P1-DIMMD1/D2/C1/C2(Black)
16	P1-NVMe 5/6: PCI-E 4.0 x8 NVMe ports
17	CPU1 (Install CPU1 first)
18	P1-NVMe 3/4: PCI-E 4.0 x8 NVMe ports
19	P1-DIMMG2/G1/H2/H1(Blue) and P1-DIMME2/E1/F2/F1(Black)
20	FP1: FFC (Flat Flexible Cable) connector
21	P1-NVMe1: PCI-E 4.0 x8 NVMe ports
22	JGPW1/JGPW2: GPU 8-pin power connectors
23	JSD1/JSD2: SATA DOM (Device_on_Module) Power Connectors
24	S-SATA0~3: SATA 3.0 Ports (Intel SCU)
25	BMC Password Label

Memory Support

CPU/DIMMs	Memory Population Sequence	* Unbalanced, not recommended.
2 CPUs & 2 DIMMs	CPU1: P1-DIMMA1 CPU2: P2-DIMMA1	
2 CPUs & 4 DIMMs	CPU1: P1-DIMMA1/P1-DIMME1 CPU2: P2-DIMMA1/P2-DIMME1	
2 CPUs & 6 DIMMs*	CPU1: P1-DIMMA1/P1-DIMME1/P1-DIMMC1/P1-DIMMG1 CPU2: P2-DIMMA1/P2-DIMME1	
2 CPUs & 8 DIMMs	CPU1: P1-DIMMA1/P1-DIMME1/P1-DIMMC1/P1-DIMMG1 CPU2: P2-DIMMA1/P2-DIMME1/P2-DIMMC1/P2-DIMMG1	
2 CPUs & 10 DIMMs*	CPU1: P1-DIMMA1/P1-DIMME1/P1-DIMMC1/P1-DIMMG1/P1-DIMMB1/P1-DIMMF1 CPU2: P2-DIMMA1/P2-DIMME1/P2-DIMMC1/P2-DIMMG1	
2 CPUs & 12 DIMMs	CPU1: P1-DIMMA1/P1-DIMME1/P1-DIMMC1/P1-DIMMG1/P1-DIMMB1/P1-DIMMF1 CPU2: P2-DIMMA1/P2-DIMME1/P2-DIMMC1/P2-DIMMG1/P2-DIMMB1/P2-DIMMF1	
2 CPUs & 14 DIMMs*	CPU1: P1-DIMMA1/P1-DIMME1/P1-DIMMC1/P1-DIMMG1/P1-DIMMB1/P1-DIMMF1/P1-DIMMD1/P1-DIMMH1 CPU2: P2-DIMMA1/P2-DIMME1/P2-DIMMC1/P2-DIMMG1/P2-DIMMB1/P2-DIMMF1	
2 CPUs & 16 DIMMs	CPU1: P1-DIMMA1/P1-DIMME1/P1-DIMMC1/P1-DIMMG1/P1-DIMMB1/P1-DIMMF1/P1-DIMMD1/P1-DIMMH1 CPU2: P2-DIMMA1/P2-DIMME1/P2-DIMMC1/P2-DIMMG1/P2-DIMMB1/P2-DIMMF1/P2-DIMMD1/P2-DIMMH1	
2 CPUs & 18 DIMMs*	CPU1: P1-DIMMA1/P1-DIMME1/P1-DIMMC1/P1-DIMMG1/P1-DIMMB1/P1-DIMMF1/P1-DIMMD1/P1-DIMMH1/P1-DIMMA2/ P1-DIMME2/P1-DIMMC2/P1-DIMMG2 CPU2: P2-DIMMA1/P2-DIMME1/P2-DIMMC1/P2-DIMMG1/P2-DIMMB1/P2-DIMMF1	
2 CPUs & 20 DIMMs*	CPU1: P1-DIMMA1/P1-DIMME1/P1-DIMMC1/P1-DIMMG1/P1-DIMMB1/P1-DIMMF1/P1-DIMMD1/P1-DIMMH1/P1-DIMMA2/ P1-DIMME2/P1-DIMMC2/P1-DIMMG2 CPU2: P2-DIMMA1/P2-DIMME1/P2-DIMMC1/P2-DIMMG1/P2-DIMMB1/P2-DIMMF1/P2-DIMMD1/P2-DIMMH1	
2 CPUs & 22 DIMMs*	CPU1: P1-DIMMA1/P1-DIMME1/P1-DIMMC1/P1-DIMMG1/P1-DIMMB1/P1-DIMMF1/P1-DIMMD1/P1-DIMMH1/P1-DIMMA2/ P1-DIMME2/P1-DIMMC2/P1-DIMMG2/P1-DIMMB2/P1-DIMMF2/P1-DIMMD2/P1-DIMMH2 CPU2: P2-DIMMA1/P2-DIMME1/P2-DIMMC1/P2-DIMMG1/P2-DIMMB1/P2-DIMMF1/P2-DIMMD1/P2-DIMMH1	
2 CPUs & 24 DIMMs	CPU1: P1-DIMMA1/P1-DIMME1/P1-DIMMC1/P1-DIMMG1/P1-DIMMB1/P1-DIMMF1/P1-DIMMD1/P1-DIMMH1/P1-DIMMA2/ P1-DIMME2/P1-DIMMC2/P1-DIMMG2/P1-DIMMB2/P1-DIMMF2/P1-DIMMD2/P1-DIMMH2 CPU2: P2-DIMMA1/P2-DIMME1/P2-DIMMC1/P2-DIMMG1/P2-DIMMB1/P2-DIMMF1/P2-DIMMD1/P2-DIMMH1	
2 CPUs & 28 DIMMs*	CPU1: P1-DIMMA1/P1-DIMME1/P1-DIMMC1/P1-DIMMG1/P1-DIMMB1/P1-DIMMF1/P1-DIMMD1/P1-DIMMH1/P1-DIMMA2/ P1-DIMME2/P1-DIMMC2/P1-DIMMG2/P1-DIMMB2/P1-DIMMF2/P1-DIMMD2/P1-DIMMH2 CPU2: P2-DIMMA1/P2-DIMME1/P2-DIMMC1/P2-DIMMG1/P2-DIMMB1/P2-DIMMF1/P2-DIMMD1/P2-DIMMH1/P2-DIMMA2/ P2-DIMME2/P2-DIMMC2/P2-DIMMG2	
2 CPUs & 32 DIMMs	CPU1: P1-DIMMA1/P1-DIMME1/P1-DIMMC1/P1-DIMMG1/P1-DIMMB1/P1-DIMMF1/P1-DIMMD1/P1-DIMMH1/P1-DIMMA2/ P1-DIMME2/P1-DIMMC2/P1-DIMMG2/P1-DIMMB2/P1-DIMMF2/P1-DIMMD2/P1-DIMMH2 CPU2: P2-DIMMA1/P2-DIMME1/P2-DIMMC1/P2-DIMMG1/P2-DIMMB1/P2-DIMMF1/P2-DIMMD1/P2-DIMMH1/P2-DIMMA2/ P2-DIMME2/P2-DIMMC2/P2-DIMMG2/P2-DIMMB2/P2-DIMMF2/P2-DIMMD2/P2-DIMMH2	

Note: Numbers of DIMM not listed are not supported

Front view

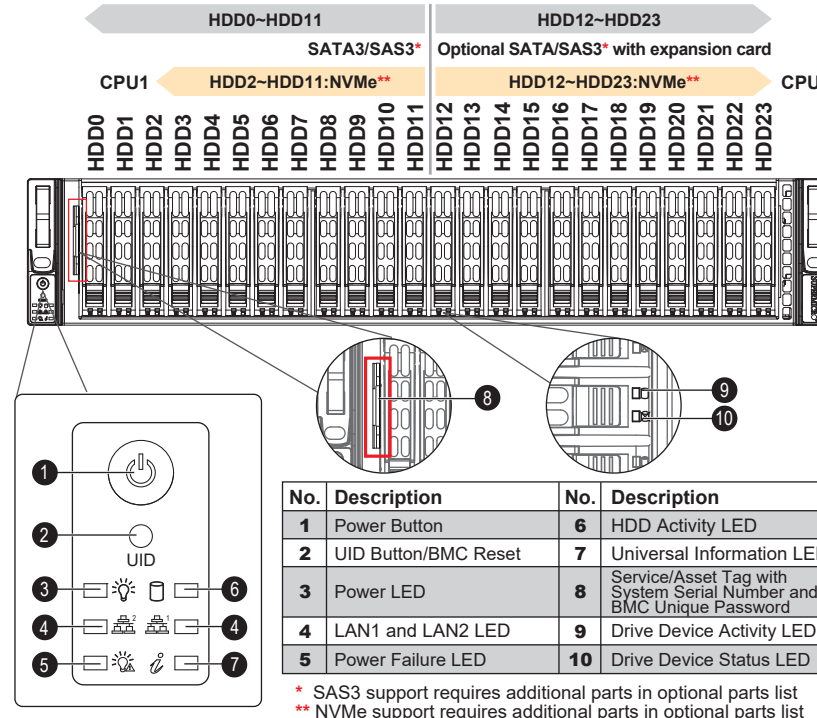

No.	Description	No.	Description
1	Power Button	6	HDD Activity LED
2	UID Button/BMC Reset	7	Universal Information LED
3	Power LED	8	Service/Asset Tag with System Serial Number and BMC Unique Password
4	LAN1 and LAN2 LED	9	Drive Device Activity LED
5	Power Failure LED	10	Drive Device Status LED

* SAS3 support requires additional parts in optional parts list
** NVMe support requires additional parts in optional parts list

Rear View

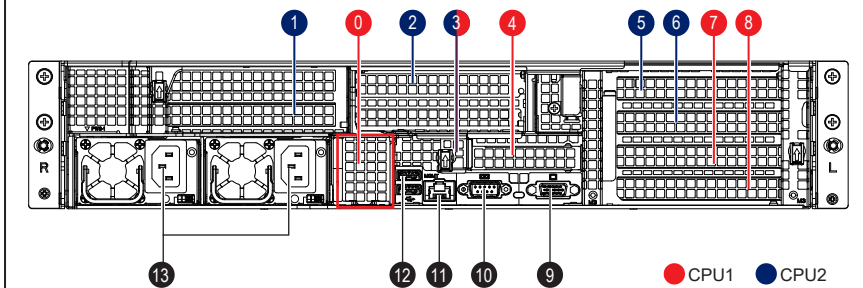

No.	Description
0	Ultra Riser Networking Slot
1	PCI-E 4.0 x16 Slot (FH, 10.5"L)
2	PCI-E 4.0 x8 (in x16) Slot (FH, 10.5"L); (PCI-E 4.0 x16 Slot with AOC-2UR668G4)
3	PCI-E 4.0 x8 (in x16) Slot (Internal LP) from CPU2; (from CPU1 with AOC-2UR668G4)
4	PCI-E 4.0 x16 Slot (LP)
5	PCI-E 4.0 x8 Slot (FH, 10.5"L)*
6	PCI-E 4.0 x8 Slot (FH, 10.5"L)*
7	PCI-E 4.0 x8 Slot (FH, 10.5"L)*
8	PCI-E 4.0 x8 Slot (FH, 10.5"L)*
9	VGA port
10	Serial Port
11	Dedicated IPMI LAN Port
12	2x USB 3.0 Ports
13	Redundant 1600W Titanium Level Power Supplies

*Optional RSC-W2-66G4 enables PCI-E x16 in slots 5, 7. Slots 6,8 will be disabled.

CPU Installation

1. Put processor into bracket – attention to the lineup Pin and key on both processor and carrier.

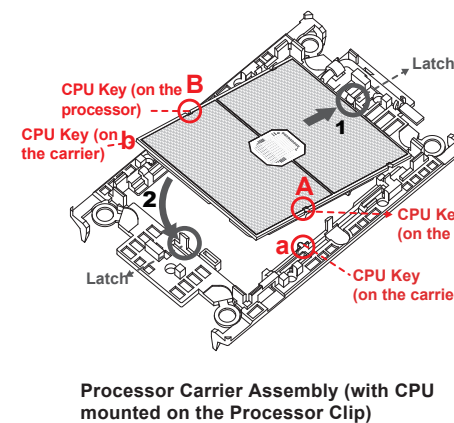

2. Put processor carrier module into HS.

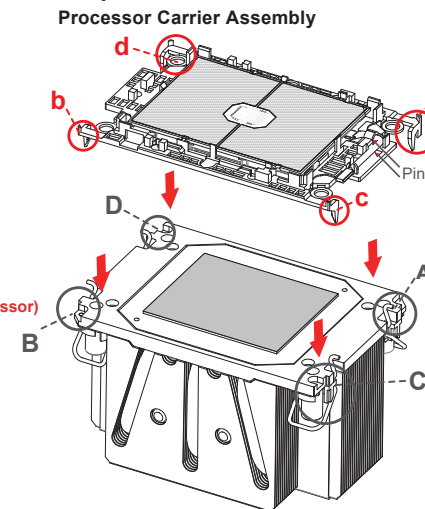

3. Put processor heatsink module into MB.

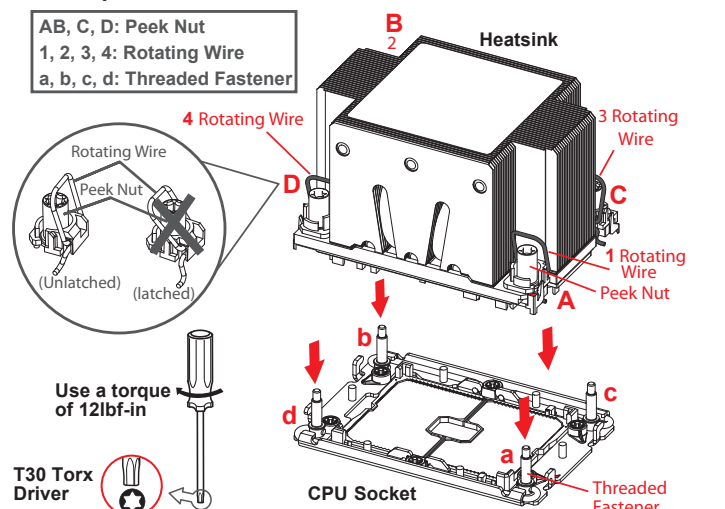

System Information

Pull-out tag with BMC unique password and Serial Number Label underneath.

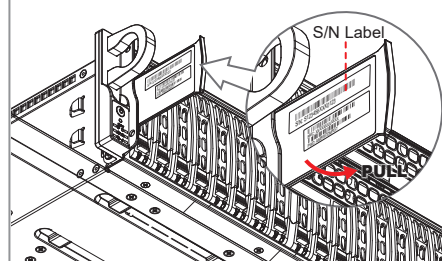

Each system comes with a unique default password for the ADMIN user. This can be found on a sticker on the motherboard and a sticker underneath the service tag on chassis. If necessary, the password can be reset by the Supermicro IPMICFG tool.

For more information, please visit <https://www.supermicro.com/en/solutions/management-software/bmc-resources>

Caution and Product Resources

SAFETY INFORMATION:
IMPORTANT: See installation instructions and safety warning before connecting system to power supply.
http://www.supermicro.com/about/policies/safety_information.cfm

WARNING:
To reduce risk of electric shock/damage to equipment, disconnect power from server by disconnecting all power cords from electrical outlets. If any CPU socket empty, install protective plastic CPU cap.

CAUTION:
Always be sure all power supplies for this system have the same power output. If mixed power supplies are installed, the system will not operate.

CAUTION:
This unit has redundant power sources. Please disconnect all the power cords before servicing.

PRODUCT RESOURCES:
For more information go to: <http://www.supermicro.com/support>

