

# SUPERMICR SuperServer 620P-TR(T) Quick Reference Guide

## Board Layout

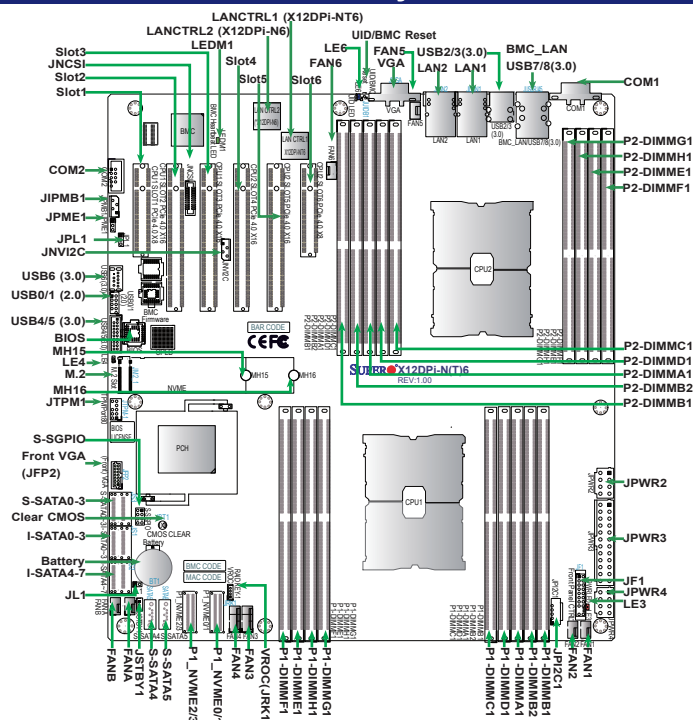

Jumper	Description	Default Setting
JBT1	CMOS Clear	Open (Normal)
JPG1	Audio Enable	Pins 1-2 (Enabled)
JPME1	ME Recovery	Pins 1-2 (Normal)
JPME2	Manufacturing Mode Select	Pins 1-2 (Normal)
JVRM1/ JVRM2	VRM SMB (to BMC or PCH)	Pins 1-2 (BMC, Normal)
JWD1	Watch Dog Timer Enable	Pins 1-2 (Reset to System)

Connector	Description
BT1	Onboard CMOS battery socket
COM1/COM2	Back panel COM port/COM header for front access
FAN1-6, FANA/FANB	System cooling fan headers (FAN1-FAN6, FAN A, FAN B)
IPMI_LAN	Dedicated IPMI_LAN port
I-SATA0-3, I-SATA4-7	SATA 3.0 connection header supported by the Intel PCH
JF1	Front Panel Control header
JHF11/JHF12	Host Fabric Interface (HFI) sideband headers for the HFI cards
JPMB1	4-pin BMC External I <sup>2</sup> C header (for an IPMI-supported card)
JL1	Chassis Intrusion header
JM2_1	M.2 slot
JNVPC	NVMe I <sup>2</sup> C header
JNVME1/JNVME2	NVMe Slot1/NVMe Slot2
JPPC1	Power Supply SMBbus I <sup>2</sup> C header
JPWR1/JPWR2	8-pin Power Supply connectors
JPWR3	24-pin ATX main power supply connector
JRK1	RAID Key for onboard SATA devices
JSTBY1	Standby power header
JTPM1	Trusted Platform Module (TPM)/Port 80 connector
LAN1/LAN2 (Note)	Gigabit LAN/10G LAN Ethernet ports on the backpanel
S-SATA0-3	S-SATA 3.0 connection Header supported by the Intel SCU
S-SATA4/S-SATA5	Powered S-SATA Ports SuperDOM (Disk On Module) devices
SLOT1	PCI-Express 4.0 X8 Slots supported by CPU1
SLOT2/SLOT3	PCI-Express 4.0 X16 Slots supported by CPU1
SLOT4/SLOT5	PCI-Express 4.0 X16 Slots supported by CPU2
SLOT6	PCI-Express 4.0 X8 Slots supported by CPU2
T-SGPIO3	General Purpose Serial I/O port
UID	Unit Identifier (UID) switch
USB0/1 (2.0)	Front Accessible USB header with two USB 2.0 connections
USB2/3, USB7/8 (3.0)	Rear I/O USB 3.0 ports
USB4/5 (3.0)	Front Accessible USB header with two USB 3.0 connections
USB6	Internal USB 3.0 Type-A header
VGA (JFP2)	Front VGA header

## Memory

Note 1: Intel Optane PMem 200 Series is supported by the 3rd Gen Intel Xeon Scalable Processor (83xx/63xx/53xx/4315) Series only.  
 Note 2: P1-DIMMB2/P2-DIMMB2 memory slots are reserved for Intel Optane PMem 200 Series only.  
 Note 3: Memory speed support depends on the processors used in the system.

Memory Support for the 3rd Gen Intel Xeon Scalable Processor					
Type	Ranks Per DIMM & Data Width	DIMM Capacity (GB)		Speed (MT/s); Voltage (V); Slot Per Channel (SPC) and DIMM Per Channel (DPC)	
		8Gb	16Gb	1DPC (1-DIMM Per Channel)	2DPC (2-DIMM Per Channel)
RDIMM	SRx8	8GB	16GB	3200	1.2V
	SRx4	16GB	32GB		
	DRx8	16GB	32GB		
RDIMM-3DS	DRx4	32GB	64GB	3200	2933*
	2H-64GB	2H-128GB	4H-256GB		
	4H-128GB	4H-256GB			
LRDIMM	QRx4	64GB	128GB	3200	3200
LRDIMM-3DS	(4R/8R)x4	4H-128GB	2H-128GB 4H-256GB	3200	3200

Validation Matrix (DDR4 DIMMS w/PMem 200 Series)			
DIMM Type	Ranks Per DIMM & Data Width (Stack)	DIMM Capacity (GB)	
		8Gb	16Gb
RDIMM (up to 3200)	1Rx8	N/A	N/A
	1Rx4	16GB	32GB
	2Rx8	16GB	32GB
	2Rx4	32GB	64GB
RDIMM 3DS (up to 3200)	4Rx4 (2H)	N/A	128GB
	8Rx4 (4H)	NA	256GB
LRDIMM (up to 3200)	4Rx4	64GB	128GB
LRDIMM 3DS (up to 3200)	4Rx4 (2H)	N/A	N/A
	8Rx4 (4H)	126GB	256GB

Memory Population Table for the 3rd Gen Intel Xeon Scalable Processor	
Memory Population for the X12 DP Motherboard, 18 DIMM Slots	
CPU/DIMMs	Memory Population Sequence
1 CPU & 1 DIMM	A1
1 CPU & 2 DIMMs*	A1, E1
1 CPU & 4 DIMMs*	A1, E1, C1, G1
1 CPU & 6 DIMM	A1, E1, C1, G1, B1, F1
1 CPU & 8 DIMMs*	A1, E1, C1, G1, B1, F1, D1, H1
1 CPU & 9 DIMMs*	A1, E1, C1, G1, B1, F1, D1, H1, B2 (B2: Reserved for PMem 200 Series only)
2 CPUs & 2 DIMMs*	CPU1: A1 CPU2: A1
2 CPUs & 4 DIMMs*	CPU1: A1, E1 CPU2: A1, E1
2 CPUs & 6 DIMMs	CPU1: A1, E1, C1, G1 CPU2: A1, E1
2 CPUs & 8 DIMMs*	CPU1: A1, E1, C1, G1 CPU2: A1, E1, C1, G1
2 CPUs & 10 DIMMs	CPU1: A1, E1, C1, G1, B1, F1 CPU2: A1, E1, C1, G1
2 CPUs & 12 DIMMs*	CPU1: A1, E1, C1, G1, B1, F1 CPU2: A1, E1, C1, G1, B1, F1
2 CPUs & 14 DIMMs	CPU1: A1, E1, C1, G1, B1, F1, D1, H1 CPU2: A1, E1, C1, G1, B1, F1
2 CPUs & 16 DIMMs*	CPU1: A1, E1, C1, G1, B1, F1, D1, H1 CPU2: A1, E1, C1, G1, B1, F1, D1, H1
2 CPUs & 18 DIMMs	CPU1: A1, E1, C1, G1, B1, F1, D1, H1, B2 (B2: Reserved for PMem 200 Series only) CPU2: A1, E1, C1, G1, B1, F1, D1, H1, B2 (B2: Reserved for PMem 200 Series only)

Note: \*To maximize memory performance, please use the memory configurations marked with "\*" above as these configurations are recommended by Supermicro for optimal memory performance.

## Front View & Interface

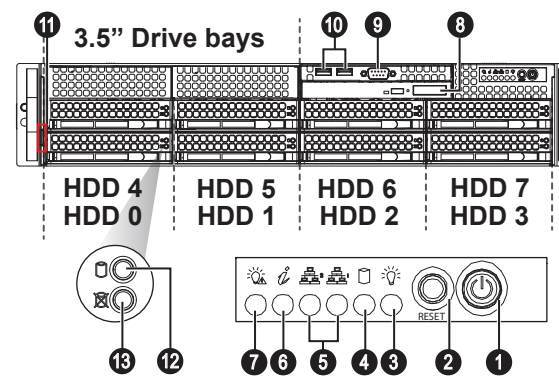

No.	Description
1	Power Button
2	Reset Button
3	Power LED
4	Device Activity LED
5	LAN1 LED & LAN2 LED
6	Information LED
7	Power Fail LED
8	DVD Drive (Optional)
9	COM2
11	Service/Asset Tag
12	Hard Drive Signal
13	Hard Drive Fail

## Rear View

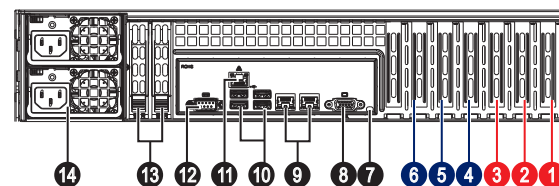

No.	Description
1	PCI-E 4.0 x8 Slot, Low Profile From CPU 1
2	PCI-E 4.0 x16 Slot, Low Profile From CPU 1
3	PCI-E 4.0 x16 Slot, Low Profile From CPU 1
4	PCI-E 4.0 x16 Slot, Low Profile From CPU 2
5	PCI-E 4.0 x16 Slot, Low Profile From CPU 2
6	PCI-E 4.0 x8 Slot, Low Profile From CPU 2
7	UID Button (Unit Identifier Button)
8	VGA Port
9	2x LAN Ports
10	USB 0/1/2/3 Ports
11	Dedicated LAN for IPMI
12	COM Port
13	Optional 2x 2.5' drives Support
14	Redundant Power Supply Modules

## System Information

Pull-out tag with BMC unique password and Serial Number Label on the left side of service tag.

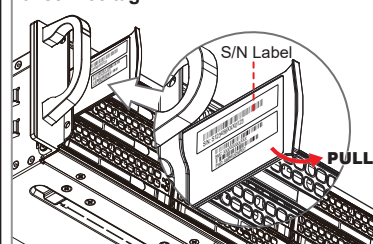

Each system comes with a unique default password for the ADMIN user. This can be found on a sticker on the motherboard and a sticker on the left side of the service tag on chassis. If necessary, the password can be reset by the Supermicro IPMICFG tool.

For more information, please visit <https://www.supermicro.com/en/solutions/management-software/bmc-resources>

## CPU/Heatsink Installation

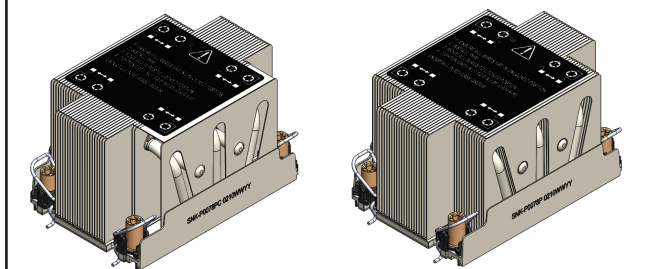
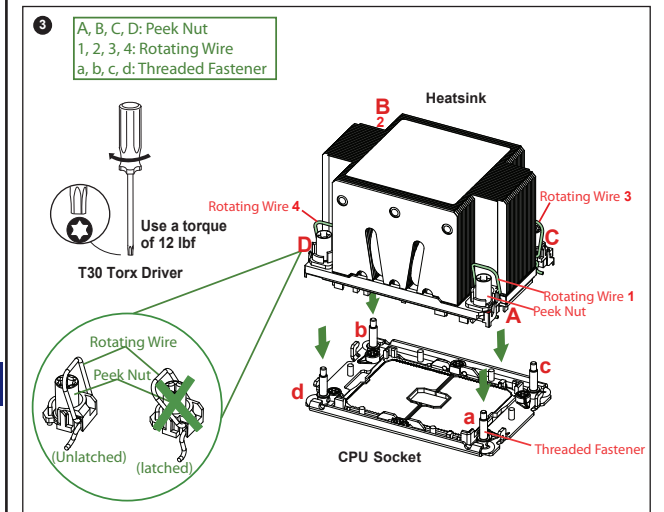
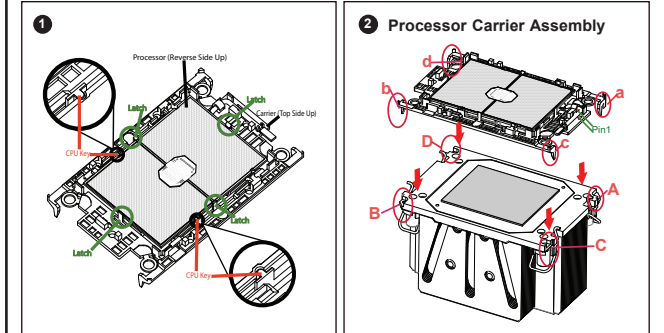

Note: Thermal grease is pre-applied on new heatsinks. No additional thermal grease is needed.

## Caution

**SAFETY INFORMATION**  
 IMPORTANT: See installation instructions and safety warning before connecting system to power supply.  
[http://www.supermicro.com/about/policies/safety\\_information.cfm](http://www.supermicro.com/about/policies/safety_information.cfm)

**WARNING**  
 To reduce risk of electric shock/damage to equipment, disconnect power from server by disconnecting all power cords from electrical outlets. If any CPU socket empty, install protective plastic CPU cap

**CAUTION**  
 Always be sure all power supplies for this system have the same power output. If mixed power supplies are installed, the system will not operate.

For more information go to : <http://www.supermicro.com/support>

