

## Board Layout

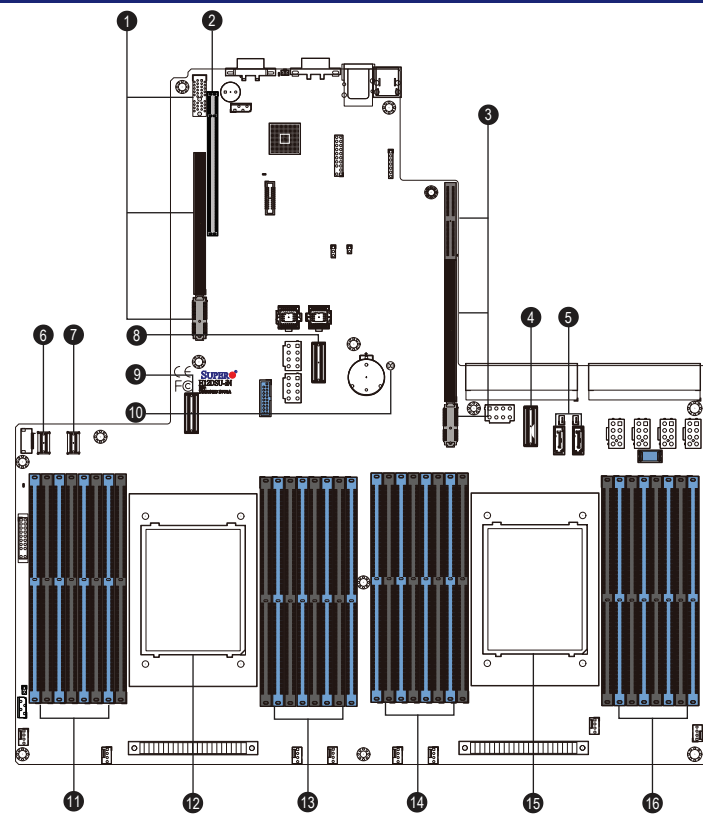

No.	Description
1	SXB1A/1B/1C: WIO-L Riser Card Support (CPU2 PCI-E 4.0 x32)
2	SXB2: WIO-R Riser Card Support (CPU2 PCI-E 4.0 x16)
3	SXB3A/3B/3C: Ultra I/O Riser Card Support (CPU1 PCI-E 4.0 x40)
4	CPU1 NVMe Ports 0-1, SATA0-7
5	SATA DOM 3.0 8-9
6	CPU2 NVMe Port 0, SATA10-13
7	CPU2 NVMe Port 1, SATA14-17
8	CPU1 NVMe Ports 2-3
9	CPU2 NVMe Ports 2-3
10	JBT1 - CMOS Clear
11	CPU2 DIMMA1-D2 Slots
12	CPU2
13	CPU2 DIMME1-H2 Slots
14	CPU1 DIMMA1-D2 Slots
15	CPU1
16	CPU1 DIMME1-H2 Slots

## Heatsink Installation

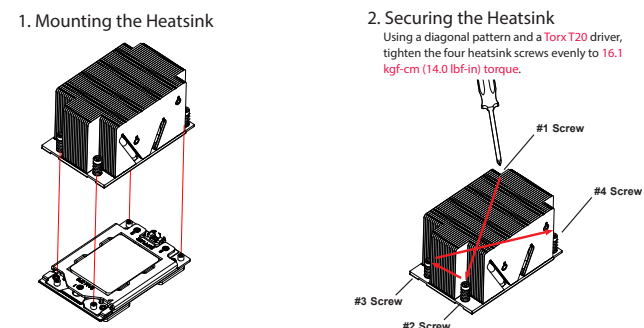

## Memory

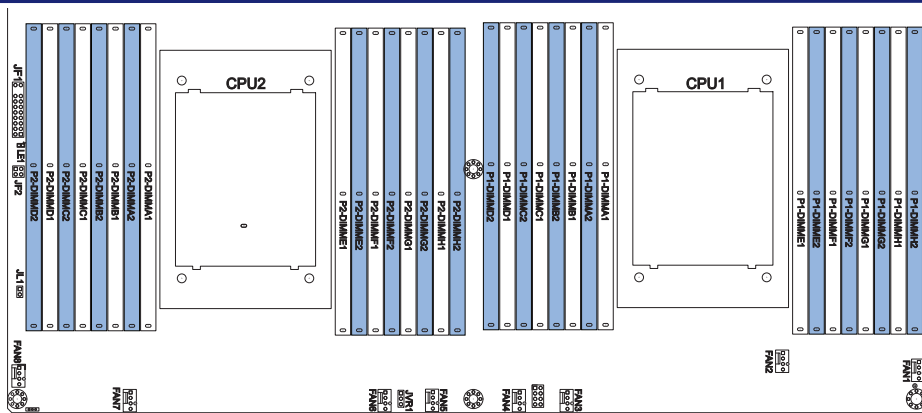

### DIMM Module Population Sequence

When installing memory modules, the DIMM slots should be populated in the following order: DIMMA2, DIMMB2, DIMMC2, DIMMD2, DIMME2, DIMMF2, DIMMG2, DIMMH2, then DIMMA1, DIMMB1, DIMMC1, DIMMD1, DIMME1, DIMMF1, DIMMG1, DIMMH1.

- The blue slots must be populated first.
- Always use DDR4 DIMM modules of the same type, size and speed.
- Mixed DIMM speeds can be installed. However, all DIMMs will run at the speed of the slowest DIMM.
- The motherboard will support odd-numbered modules (1 or 3 modules installed). However, to achieve the best memory performance, fully populate the motherboard with validated memory modules.

### Processors and Their Corresponding Memory Modules

CPU#	Channel 1	Channel 2	Channel 3	Channel 4	Channel 5	Channel 6	Channel 7	Channel 8								
<b>8 DIMMS</b>																
CPU1			C2	D2			G2	H2								
CPU2			C2	D2			G2	H2								
<b>16 DIMMS</b>																
CPU1	A2	B2	C2	D2	E2	F2	G2	H2								
CPU2	A2	B2	C2	D2	E2	F2	G2	H2								
<b>32 DIMMS</b>																
CPU1	A1	A2	B1	B2	C1	C2	D1	D2	E1	E2	F1	F2	G1	G2	H1	H2
CPU2	A1	A2	B1	B2	C1	C2	D1	D2	E1	E2	F1	F2	G1	G2	H1	H2

## Hard Drive Installation

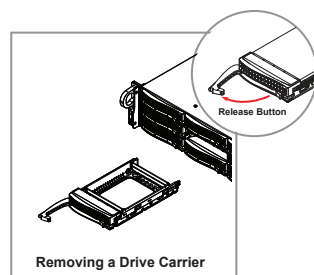

### Removing a Hot-Swap Drive Carrier from the Chassis

- Press the release button on the drive carrier, which will extend the drive carrier handle.
- Use the drive carrier handle to pull the drive out of the chassis.

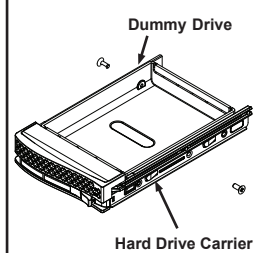

### Installing a Drive

- Remove the dummy drive, by removing the screws securing the dummy drive to the carrier. These screws are not used to mount the actual hard drive.
- Insert a drive into the carrier with the PCB side facing down and the connector end toward the rear of the carrier. Align the drive in the carrier so that the screw holes line up.
- Secure the drive to the carrier with four M3 screws, included in the chassis accessory box.
- Insert the drive carrier with the disk drive into its bay, keeping the carrier oriented so that the release button is on the right side. When the carrier reaches the rear of the bay, the release handle retracts.
- Push the handle in until it clicks into its locked position.

## Front View & Interface

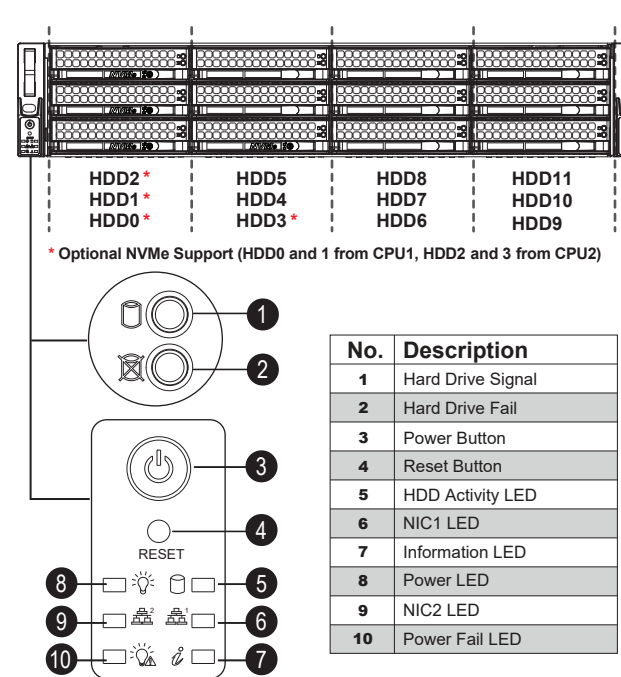

HDD2\* HDD5 HDD8 HDD11  
HDD1\* HDD4 HDD7 HDD10  
HDD0\* HDD3\* HDD6 HDD9

\* Optional NVMe Support (HDD0 and 1 from CPU1, HDD2 and 3 from CPU2)

No.	Description
1	Hard Drive Signal
2	Hard Drive Fail
3	Power Button
4	Reset Button
5	HDD Activity LED
6	NIC1 LED
7	Information LED
8	Power LED
9	NIC2 LED
10	Power Fail LED

## Rear View

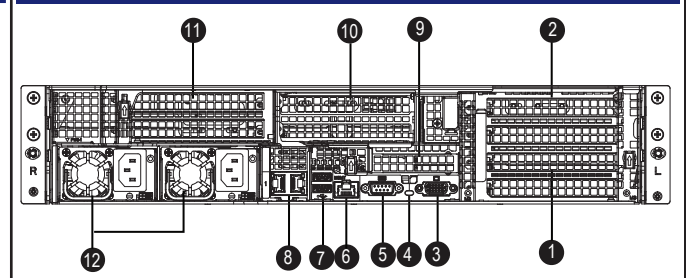

No.	Description
1	PCI-E x16 Slot (FH, 9.5" L)
2	PCI-E x16 Slot (FH, 10.5" L)
3	VGA Port
4	UID LED
5	Serial Port
6	Dedicated LAN for IPMI
7	Two USB 3.0 Ports
8	Two 10G RJ45 Ports (Ultra Riser Card)
9	PCI-E x16 Slot (LP)
10	PCI-E x8 in x16 Slot (FH, 10.5" L)
11	PCI-E x16 Slot (FH, 10.5" L)
12	Redundant Power Supply Modules*

\*Redundancy based on configuration and application load

## CPU Installation

### Processor Installation

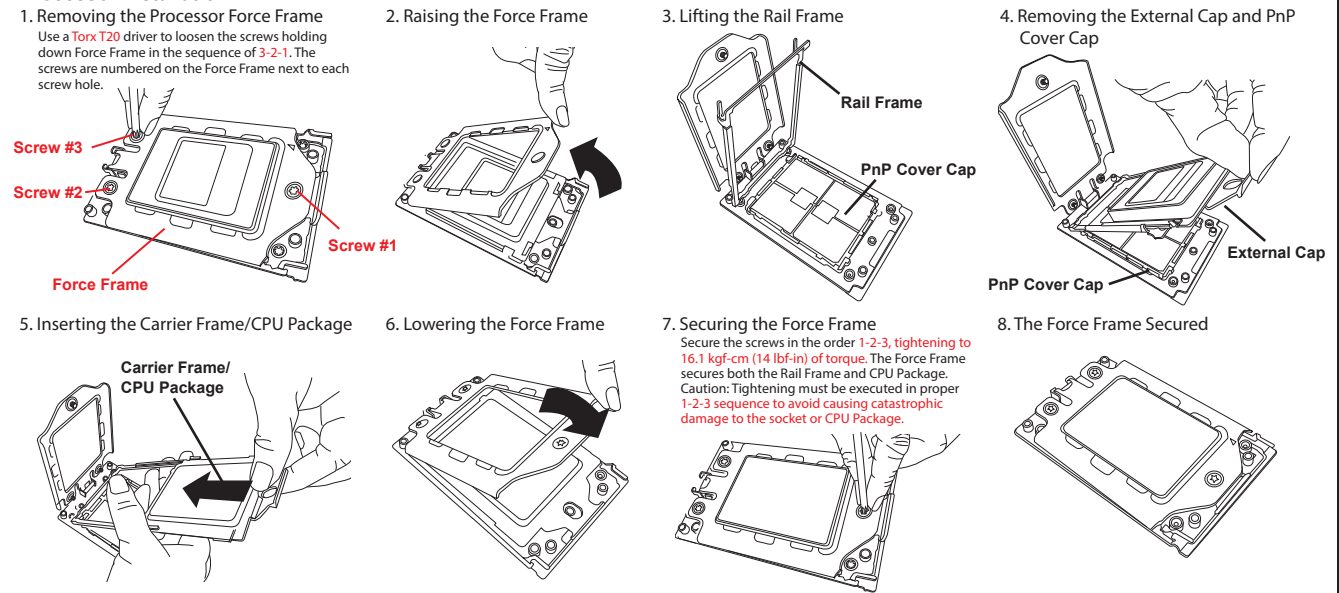

## Default Cable Routing

Connector on Board/Card	Connection Backplane	HDD Bay	SMC Cable P/N
JSLIM1 (MB-H12DSU-IN)	CN1, CN2	0-7	CBL-SAST-1253-100
JSLIM3-2 (MB-H12DSU-IN)	CN3	8-11	CBL-SAST-1269F-100
JSLIM2 (MB-H12DSU-IN)	NVMe1	0-1 (Hybrid with SATA)	CBL-SAST-1247-85
JSLIM4 (MB-H12DSU-IN)	NVMe2	2-3 (Hybrid with SATA)	CBL-SAST-1245-85

## Caution

**SAFETY INFORMATION**  
IMPORTANT: See installation instructions and safety warning before connecting system to power supply.  
[http://www.supermicro.com/about/policies/safety\\_information.cfm](http://www.supermicro.com/about/policies/safety_information.cfm)

**WARNING:**  
To reduce risk of electric shock/damage to equipment, disconnect power from server by disconnecting all power cords from electrical outlets. If any CPU socket empty, install protective plastic CPU cap.

**WARNING:**  
Always be sure all power supplies for this system have the same power output. If mixed power supplies are installed, the system will not operate. For more information go to : <http://www.supermicro.com/support>

