

SUPERMICR[®] 211GT-HNTR/HNC8R Quick Reference Guide

Board Layout

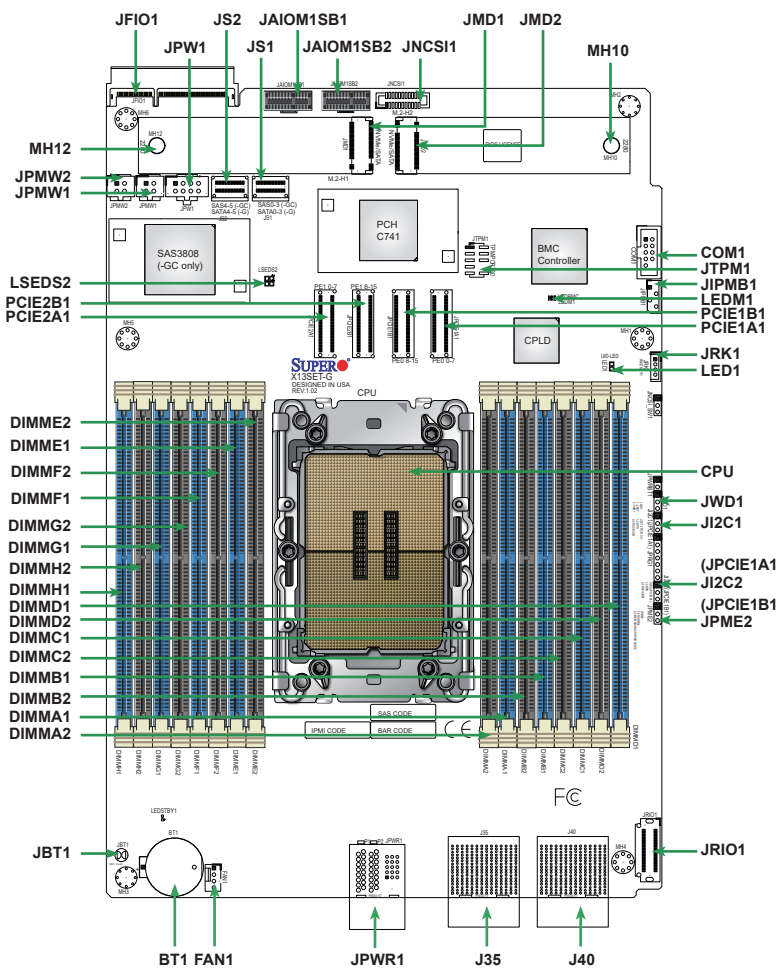

Jumper	Description	Default Setting
JBT1	CMOS Clear	Open (Normal)
JPC1, JPC2	Backplane or Riser Card/AIOM Enable	Pins 1-2 (RSC/AIOM)
JPME2	ME Manufacturing Mode	Pins 1-2 (Normal)
JWD1	Watch Dog Timer	Pins 1-2 (Reset)

LED	Description	Status
LED1	UID LED	Solid Blue: Unit Identified
LEDM1	BMC Heartbeat	Blinking Green: BMC Normal
LSEDS2	SAS Heartbeat	Blinking Green: SAS Active

Connector	Description
AIOM1SB1	AIOM1 Sideband Signals Header
AIOM1SB2	AIOM2 Sideband Signals Header
BT1	Onboard battery
COM1	COM Header
FAN1	CPU/System Fan Header (FAN1: CPU Fan)
J35, J40	Molex Impel Plus Connectors
JFIO	Grand Twin Front IPMI And Onboard NIC Module Connector
JIPMB1	System Management Bus Header (for IPMI only)
JMD1, JMD2	M.2 Slots (PCIe3.0 x4 and SATA)
JNCSI1	NC-SI (Network Controller Sideband Interface) Connector
JPMW1, JPMW2	Power Connectors for PCIe or GPU
JPCIE1A1	PE0 0-7 PCIe Connector
JPCIE1B1	PE0 8-15 PCIe Connector
JPCIE2A1	PE1 0-7 PCIe Connector
JPCIE2B1	PE1 8-15 PCIe Connector
JPW1	Power Connector for Storage Backplane
JPWR1	BPN-PDB-GT214 Connector for Power Supply
JRIO1	Connector for Rear I/O Module
JRK1	Intel RAID Key Header
JS1	X13SET-G: SATA0-3, X13SET-GC: SAS0-3
JS2	X13SET-G: SATA4-5, X13SET-GC: SAS4-5
JTPM1	Trusted Platform Module/Port 80 Connector
MH10, MH12	M.2 Mounting Holes

Memory Support

1 CPU, 16 DIMM Slots	
Number of DIMMs	Memory Population Sequence
1	DIMMA1 DIMME1 DIMMB1 DIMMF1
2	DIMMA1 / DIMMG1 DIMMC1 / DIMME1
4	DIMMA1 / DIMMG1 / DIMMC1 / DIMME1
6	DIMMA1 / DIMMG1 / DIMMC1 / DIMME1 / DIMMD1 / DIMMF1 DIMMC1 / DIMME1 / DIMMB1 / DIMMH1 / DIMMD1 / DIMMF1 DIMMA1 / DIMMG1 / DIMMB1 / DIMMH1 / DIMMD1 / DIMMF1
8	DIMMA1 / DIMMG1 / DIMMB1 / DIMMH1 / DIMMD1 / DIMMF1 / DIMMC1 / DIMME1
12	DIMMA1 / DIMMA2 / DIMMB1 / DIMMC1 / DIMMC2 / DIMMD1 / DIMME1 / DIMME2 / DIMMF1 / DIMMG1 / DIMMG2 / DIMMH1 DIMMA1 / DIMMB1 / DIMMB2 / DIMMC1 / DIMMD1 / DIMMD2 / DIMME1 / DIMMF1 / DIMMF2 / DIMMG1 / DIMMH1 / DIMMH2
16	DIMMA1 / DIMMA2 / DIMMB1 / DIMMB2 / DIMMC1 / DIMMC2 / DIMMD1 / DIMMD2 / DIMME1 / DIMME2 / DIMMF1 / DIMMF2 / DIMMG1 / DIMMG2 / DIMMH1 / DIMMH2

1 HBM CPU, 16 DIMM Slots	
Number of DIMMs	Memory Population Sequence
0	
1	DIMMA1 DIMME1
2	DIMMA1 / DIMMG1 DIMMC1 / DIMME1
4	DIMMA1 / DIMMG1 / DIMMC1 / DIMME1
8	DIMMA1 / DIMMG1 / DIMMC1 / DIMME1 / DIMMD1 / DIMMF1 / DIMMB1 / DIMMH1
16	DIMMA1 / DIMMA2 / DIMMB1 / DIMMB2 / DIMMC1 / DIMMC2 / DIMMD1 / DIMMD2 / DIMME1 / DIMME2 / DIMMF1 / DIMMF2 / DIMMG1 / DIMMG2 / DIMMH1 / DIMMH2

Compatible and Incompatible DIMM Types in a Channel and a System			
DIMM Type	RDIMM	RDIMM 3DS	9x4 RDIMM
RDIMM	Compatible	Incompatible	Incompatible
RDIMM 3DS	Incompatible	Compatible	Incompatible
9x4 RDIMM	Incompatible	Incompatible	Compatible

Air Shroud installation

1. Ensure the CPU, CPU heatsinks, and configured DIMMs are installed.
2. Align the mountings screw holes in the plastic air shroud with those in the node interior and lower the air shroud into the node until it is firmly seated.
3. Secure the air shroud with the two tall standoffs provided. Be careful that the air shroud legs at either end do not interfere with any motherboard components such as cables.
4. Secure the cable protector with the two screws tightened on top of the two tall standoffs in order to cover or manage any loose cables that interfere with the air shroud placement.

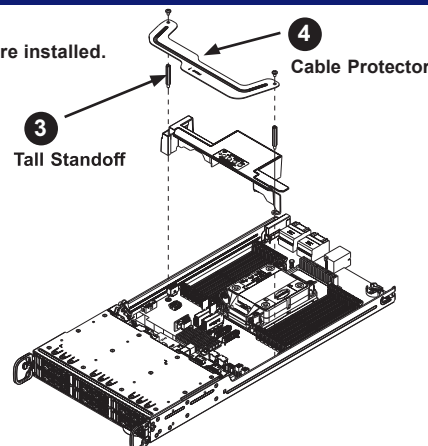

Nodes and Corresponding Hard Drives

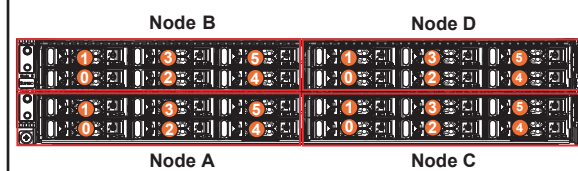

Nodes Drawer Locations	
Node B controls drives B0, B1, B2, B3, B4, and B5	Node D controls drives D0, D1, D2, D3, D4, and D5
Node A controls drives A0, A1, A2, A3, A4, and A5	Node C controls drives C0, C1, C2, C3, C4, and C5

Front view & Interface

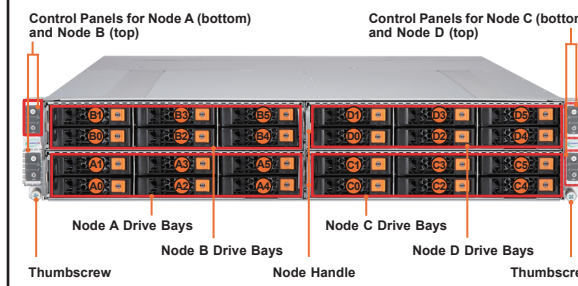

Front Chassis Features	
Feature	Description
Control Panel	Four control panels with labels located as follows: node A bottom left, node B top left, node C bottom right, and node D top right.
Service Tag	Pull-out service tags with BMC password labels for each node.
Drive Bays	24 hot-swap drive bays (six per node)
Node Handles	Handle supporting node tray removal
Thumbscrews	Two thumbscrews to secure the server onto the rack

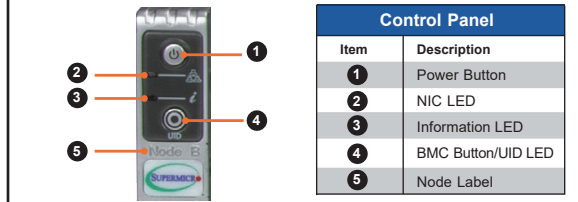

Rear View

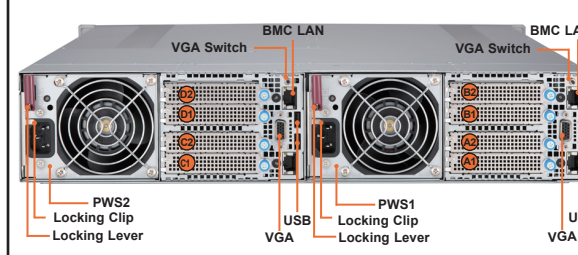

Rear Chassis Features	
Feature	Description
Locking Clip/Lever	Power supply locking mechanisms
BMC LAN	Dedicated BMC LAN port
USB	Two USB 3.0 ports (shared by upper and lower nodes)
VGA	VGA port (shared by upper and lower nodes)
VGA Switch	Toggles VGA output between upper and lower nodes.
Power Supplies	Two 2200 W Titanium level redundant power supply modules PWS2 on the left, and PWS1 on the right
ⓐ through ⓑ	PCIe 5.0 x16 AIOM (OCP 3.0) expansion slots

CPU Installation

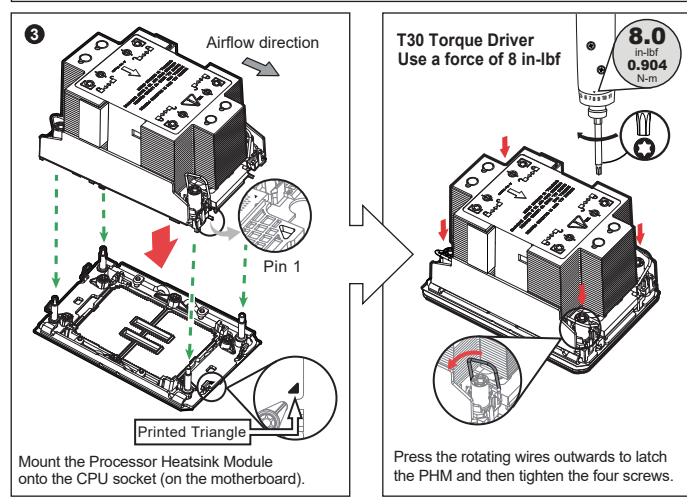
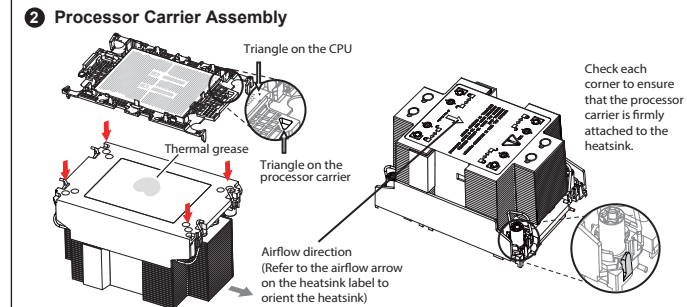
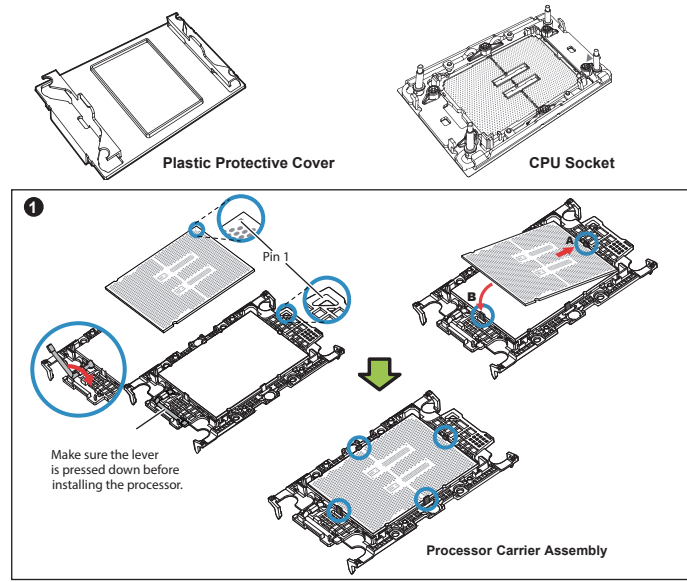

Caution

SAFETY INFORMATION
 IMPORTANT: See installation instructions and safety warning before connecting system to power supply.
http://www.supermicro.com/about/policies/safety_information.cfm

WARNING:
 To reduce risk of electric shock/damage to equipment, disconnect power from server by disconnecting all power cords from electrical outlets. If any CPU socket empty, install protective plastic CPU cap

WARNING:
 Always be sure all power supplies for this system have the same power output. If mixed power supplies are installed, the system will not operate. For more information go to : <http://www.supermicro.com/support>

