

SUPERMICR[®] SuperServer 221H-TNR Quick Reference Guide

Board Layout

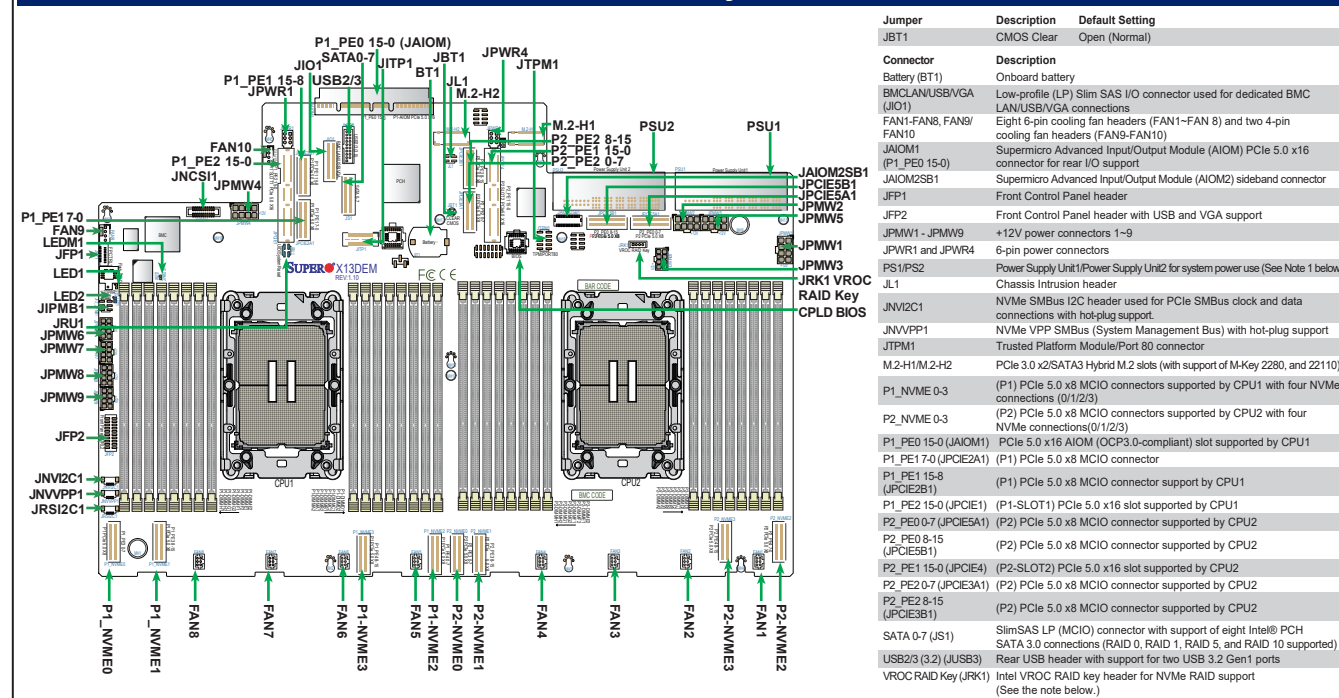

CPU Installation

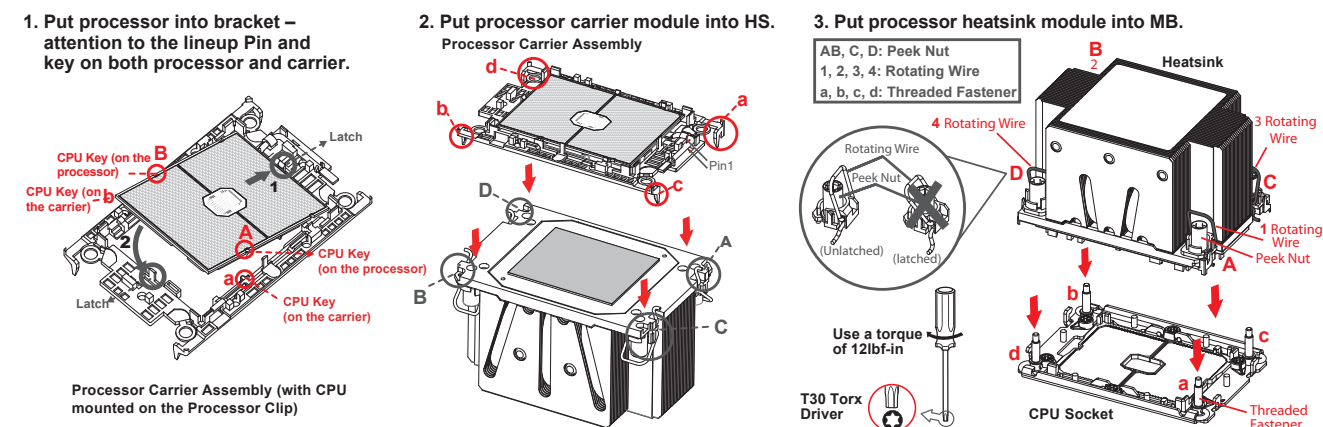

Memory Support

| DDR5 Memory Population Table for X13DP Motherboards (with 32 DIMMs installed) | |
|---|--|
| 2 CPUs: (Recommended) | Memory Population Sequence |
| 2 CPUs & 2 DIMMs | CPU1 and CPU2: A1, or B1 or E1 or F1 |
| 2 CPUs & 4 DIMMs | CPU1 and CPU2: A1, G1 or C1, E1 |
| 2 CPUs & 8 DIMMs | CPU1: A1, C1, E1, G1 CPU2: A1, C1, E1, G1 |
| 2 CPUs & 10 DIMMs | CPU1: A1, C1, D1, E1, F1, G1 CPU2: A1, C1, E1, G1 |
| 2 CPUs & 12 DIMMs | CPU1: A1, C1, D1, E1, F1, G1 and CPU2: A1, C1, D1, E1, F1, G1 or CPU1: A1, B1, C1, E1, G1, H1 and CPU2: A1, B1, C1, E1, G1, H1 or CPU1: B1, C1, D1, E1, F1, H1 and CPU2: B1, C1, D1, E1, F1, H1 or CPU1: A1, B1, D1, F1, G1, H1 and CPU2: A1, B1, D1, F1, G1, H1 |
| 2 CPUs & 16 DIMMs | CPU1: A1, B1, C1, D1, E1, F1, G1, H1 CPU2: A1, B1, C1, D1, E1, F1, G1, H1 |
| 2 CPUs & 22 DIMMs | CPU1: A1, A2, B1, B2, C1, C2, D1, D2, E1, E2, F1, F2, G1, G2, H1, H2 CPU2: A1, C1, D1, E1, F1, G1 |
| 2 CPUs & 24 DIMMs | CPU1: A1, A2, B1, B2, C1, C2, D1, D2, E1, E2, F1, F2, G1, G2, H1, H2 CPU2: A1, B1, C1, D1, E1, F1, G1, H1 |
| 2 CPUs & 32 DIMMs | CPU1: A1, A2, B1, B2, C1, C2, D1, D2, E1, E2, F1, F2, G1, G2, H1, H2 CPU2: A1, A2, B1, B2, C1, C2, D1, D2, E1, E2, F1, F2, G1, G2, H1, H2 |

Front View

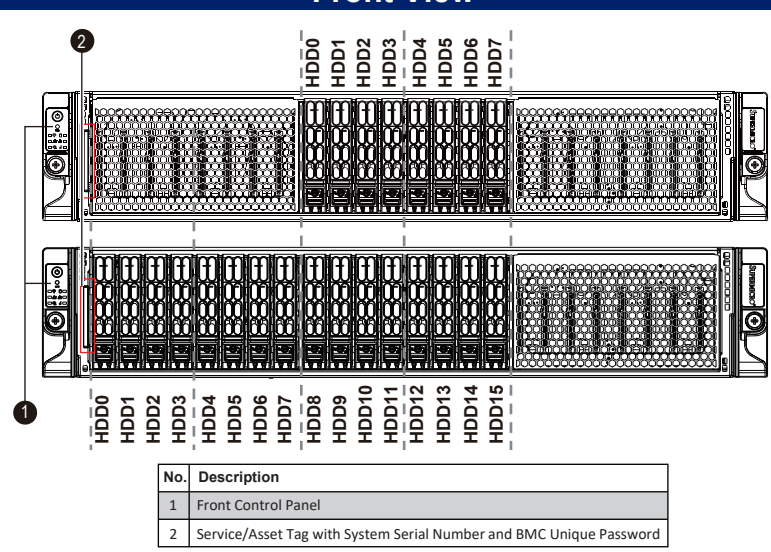

System Information

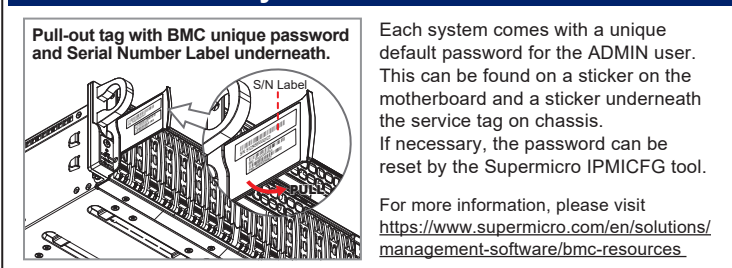

Caution and Product Resources

SAFETY INFORMATION:

IMPORTANT: See installation instructions and safety warning before connecting system to power supply. http://www.supermicro.com/about/policies/safety_information.cfm

WARNING:

To reduce risk of electric shock/damage to equipment, disconnect power from server by disconnecting all power cords from electrical outlets. If any CPU socket empty, install protective plastic CPU cap.

CAUTION:

Always be sure all power supplies for this system have the same power output. If mixed power supplies are installed, the system will not operate.

CAUTION:

This unit has redundant power sources. Please disconnect all the power cords before servicing.

PRODUCT RESOURCES:

For more information go to: <http://www.supermicro.com/support>

Rear View

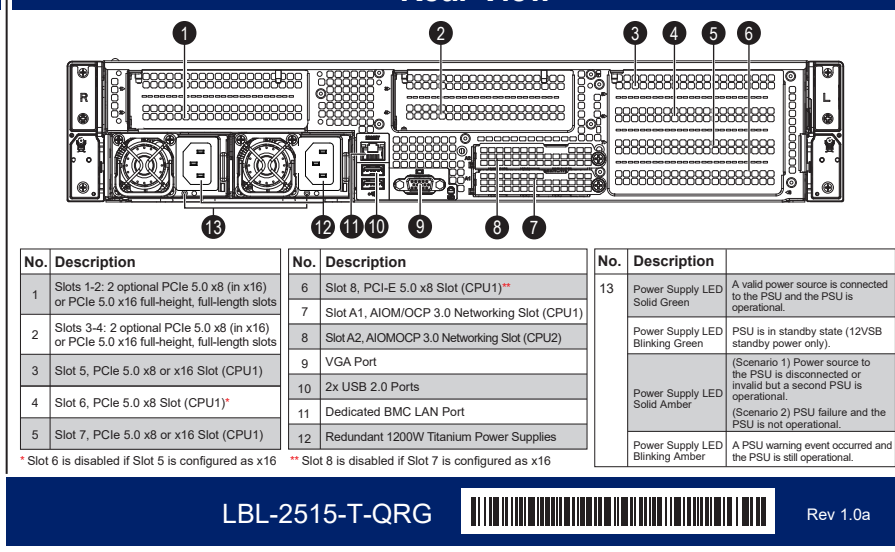

LBL-2515-T-QRG Rev 1.0a

NVMe Drive Bay Cable Routing

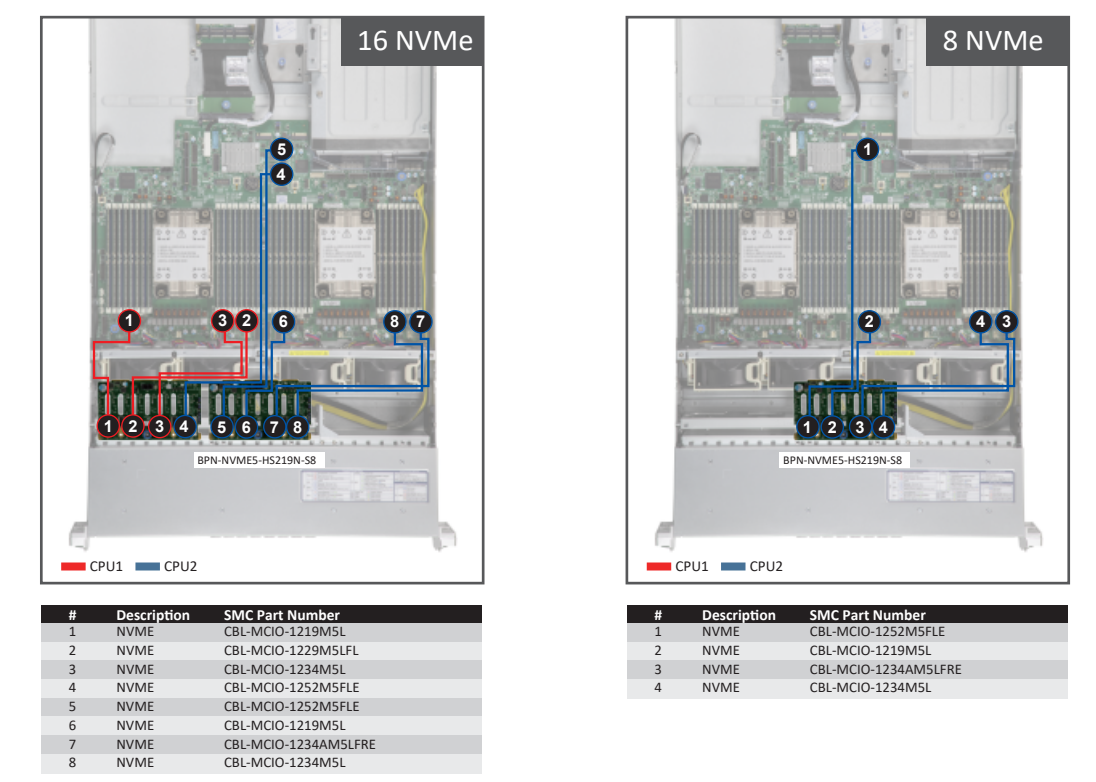

Storage AOC Drive Bay Cable Routing

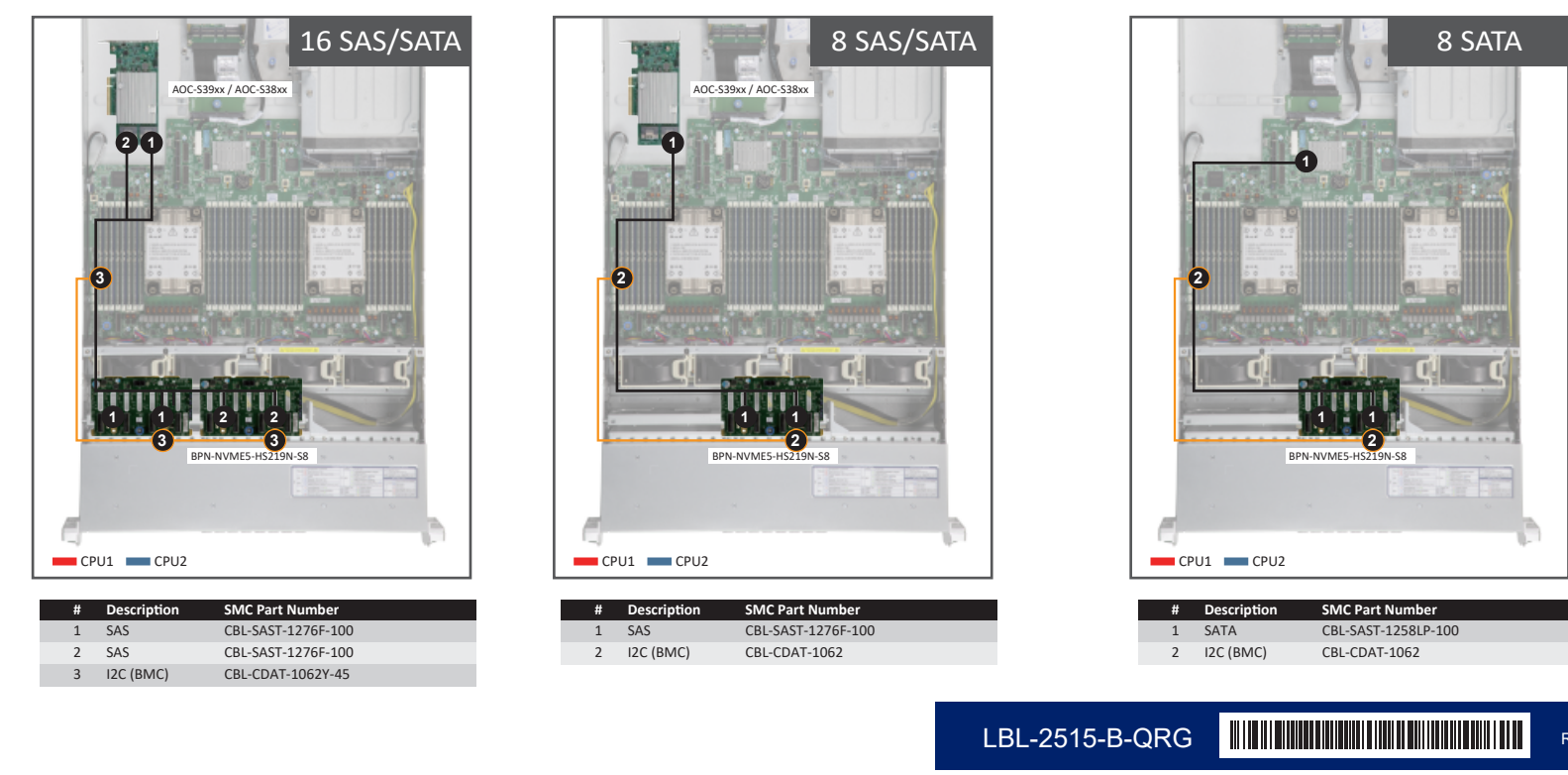

LBL-2515-B-QRG Rev 1.0a