

SUPERMICR SuperServer 221P-C9R(T) Quick Reference Guide

Board Layout

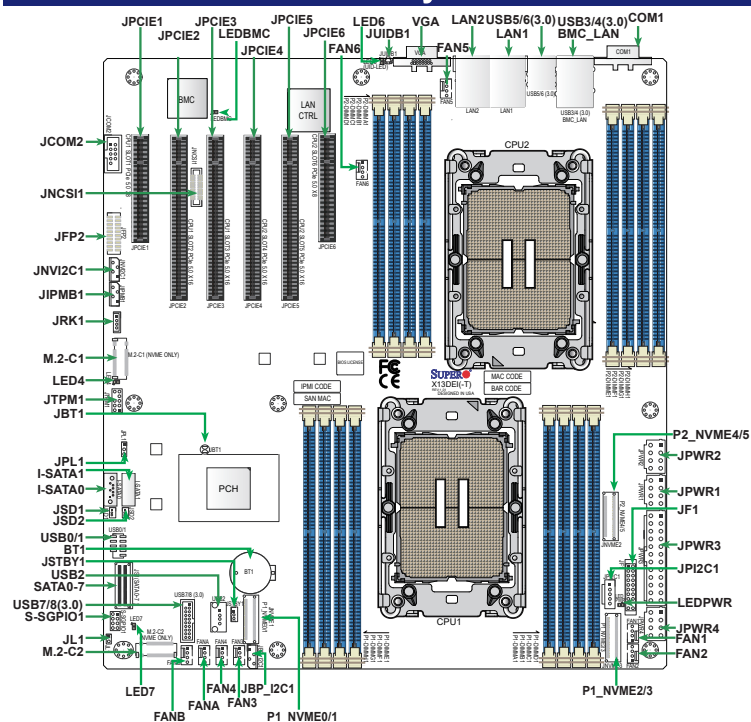

Jumper	Description	Default Setting	LED	Description	Status
JBT1	CMOS Clear	Open (Normal)	LED4, LED7	M.2 LEDs (for M.2-C1, M.2-C2)	Blinking Green: Device Working
JPL1	LAN1, LAN2 Enable/Disable	Pins 1-2 (Enabled)	LED6	Unit Identifier (UID) LED	Solid Blue: Unit Identified
			LEDBMC	BMC Heartbeat LED	Blinking Green: BMC Normal (Active), Solid Green: (During BMC Reset or during a Cold Reboot)
			LEDPWR	Power LED	LED On: Onboard Power On

Connector	Description
BT1	Onboard CMOS Battery
BMC_LAN	Dedicated BMC LAN Port
COM1	Rear I/O COM Port
FAN1 - FAN6, FANA, FANB	CPU/System Fan Headers
I-SATA0, I-SATA1	Intel PCH Powered I-SATA 3.0 Ports with support of SuperDOM devices *DOM: Disk on Module
JBP_I2C1	4-pin BMC External I2C Header
JCOM2	Front Accessible COM Port Header
JF1	Front Control Panel Header
JFP2	Front Accessible VGA Connection Header
JIPMB1	4-pin BMC External I2C Header (for Inlet Temperature Sensor)
JL1	Chassis Intrusion Header
JNCS11	NC-SI (Network Controller Sideband Interface) Connector
JNV12C1	NVMe SMBus I2C Header with hot-plug support
JPCIE1 (SLOT1), JPCIE6 (SLOT6)	PCIe 5.0 x8 Slots (SLOT1: supported by CPU1, SLOT6: supported by CPU2)
JPCIE2/3 (SLOT2/3), JPCIE4/5 (SLOT4/5)	PCIe 5.0 x16 Slots (SLOT2/3: supported by CPU1, SLOT4/5: supported by CPU2)
JP12C1	Power System Management Bus (SMBus) I2C Header
JPWR1, JPWR2, JPWR4	8-pin Power Connectors
JPWR3	24-pin ATX Power Connector
JS1 (SATA 0 - SATA7)	SlimSAS x8 Connector with support of eight Intel PCH SATA 3.0 connections (RAID 0, 1, 5, and 10 supported)
JSD1, JSD2	SATA DOM Power Connectors
JSTBY1	5V Standby Power Header
JSD1, JSD2	SATA DOM Power Connectors
JSTBY1	5V Standby Power Header
JTPM1	Trusted Platform Module/Port 80 Header
JUIDB1	Unit Identifier (UID) Switch / BMC Reset Button
LAN1, LAN2	Ethernet LAN (RJ45) Port 1 and Port 2 (1G LAN support on X13DE1 and 10G LAN support on X13DE1-T)
M.2-C1, M.2-C2	PCIe 4.0 x2 NVMe M.2 Slots supported by CPU1 (with support of M-Key 2280 and 22110)
P1_NVME0/1 (JNVME1), P1_NVME2/3 (JNVME2)	MCIO x8 Connectors supported by CPU1 with four PCIe 5.0 x4 NVMe connections
P2_NVME4/5 (JNVME3)	MCIO x8 Connector supported by CPU2 with two PCIe 5.0 x4 NVMe connections
S-SGPI01	Serial General Purpose I/O Header (for I-SATA0/1 SuperDOM support)
USB0/1	USB 2.0 Header with support of two USB connections
USB2	Internal USB 2.0 Vertical Type-A Connector
USB3/4 (3.0)	Back Panel USB 3.0 Ports (5Gbps, Type-A)
USB5/6 (3.0)	Back Panel USB 3.0 Ports (5Gbps, Type-A)
USB7/8 (3.0)	USB 3.0 Header with support of two USB connections
VGA	Rear I/O VGA Port

Memory

DIMM Population Guidelines for Optimal Performance

Type	Ranks Per DIMM & Data Width (Stack)	DIMM Capacity (GB)		Speed (MT/s); Voltage (V); DIMM Per Channel (DPC)	
		16 Gb (DRAM Density)	24 Gb (DRAM Density)	1DPC ^{Note 1}	2DPC
RDIMM	SRx8 (RC D)	16 GB	24 GB ^{Note 2}	5600	1.1V
	SRx4 (RC C)	32 GB	48 GB ^{Note 2}		
	SRx4 (RC F) 9x4	32 GB	48 GB ^{Note 2}		
	DRx8 (RC E)	32 GB	48 GB ^{Note 2}		
	DRx4 (RC A)	64 GB	96 GB		
RDIMM 3DS	DRx4 (RC B) 9x4	64 GB	96 GB	4400	
	(4R/8R) x4 (RC A)	2H-128 GB 4H-256 GB	N/A	Not Supported	Not Supported
LRDIMM/LRDIMM-3DS	N/A	N/A	N/A	Not Supported	Not Supported

Note 1: 1DPC applies to 1 SPC (Sockets Per Channel) or 2 SPC implementation.
Note 2: The 24 Gb 2DPC configuration with 24 GB and 48 GB DIMMs is NOT recommended.

Type	Ranks Per DIMM & Data Width (Stack)	DIMM Capacity (GB)	Speed (MT/s); Voltage (V); DIMM Per Channel (DPC)	
			1DPC (Note)	2DPC
RDIMM	SRx8 (RC D)	16GB	4800	4400
	SRx4 (RC C)	32GB		
	SRx4 (RC F) 9x4	32GB		
	DRx8 (RC E)	64GB		
	DRx4 (RC A)	64GB		
RDIMM 3DS	DRx4 (RC B) 9x4	64GB		
	(4R/8R) x4 (RC A)	2H-128GB 4H-256GB	Not Supported	Not Supported
LRDIMM/LRDIMM-3DS	N/A	N/A	Not Supported	Not Supported

Note: This memory configuration is recommended by Supermicro for optimal memory performance. Please use this configuration to maximize your memory performance.

DDR5 Memory Population Table for X13 DP Motherboards (with 16 DIMMs installed)	
1 CPU	Memory Population Sequence
1 CPU & 1 DIMM	P1-DIMMA1 or P1-DIMME1 or P1-DIMMB1 or P1-DIMMF1
1 CPU & 2 DIMMs	P1-DIMMA1 / P1-DIMMG1 or P1-DIMMC1 / P1-DIMME1
1 CPU & 4 DIMMs	P1-DIMMA1 / P1-DIMMC1 / P1-DIMME1 / P1-DIMMG1
1 CPU & 6 DIMM	P1-DIMMA1 / P1-DIMMC1 / P1-DIMMD1 / P1-DIMME1 / P1-DIMMF1 / P1-DIMMG1 or P1-DIMMA1 / P1-DIMMB1 / P1-DIMMC1 / P1-DIMME1 / P1-DIMMG1 / P1-DIMMH1 or P1-DIMMB1 / P1-DIMMC1 / P1-DIMMD1 / P1-DIMME1 / P1-DIMMF1 / P1-DIMMH1 or P1-DIMMA1 / P1-DIMMB1 / P1-DIMMD1 / P1-DIMME1 / P1-DIMMF1 / P1-DIMMG1 / P1-DIMMH1
1 CPU & 8 DIMMs	P1-DIMMA1 / P1-DIMMB1 / P1-DIMMC1 / P1-DIMME1 / P1-DIMMF1 / P1-DIMMG1 / P1-DIMMH1
2 CPUs (Recommended)	Memory Population Sequence
2 CPUs & 2 DIMMs	CPU1: P1-DIMMA1, CPU2: P2-DIMMA1 or CPU1: P1-DIMME1, CPU2: P2-DIMME1 or CPU1: P1-DIMMB1, CPU2: P2-DIMMB1 or CPU1: P1-DIMMF1, CPU2: P2-DIMMF1
2 CPUs & 4 DIMMs	CPU1: P1-DIMMA1 / P1-DIMMG1, CPU2: P2-DIMMA1 / P2-DIMMG1 or CPU1: P1-DIMMC1 / P1-DIMME1, CPU2: P2-DIMMC1 / P2-DIMME1
2 CPUs & 8 DIMMs	CPU1: P1-DIMMA1 / P1-DIMMC1 / P1-DIMME1 / P1-DIMMG1 CPU2: P2-DIMMA1 / P2-DIMMC1 / P2-DIMME1 / P2-DIMMG1
2 CPUs & 12 DIMMs	CPU1: P1-DIMMA1 / P1-DIMMB1 / P1-DIMMC1 / P1-DIMME1 / P1-DIMMF1 / P1-DIMMG1 CPU2: P2-DIMMA1 / P2-DIMMB1 / P2-DIMMC1 / P2-DIMME1 / P2-DIMMF1 / P2-DIMMG1 CPU1: P1-DIMMA1 / P1-DIMMB1 / P1-DIMMD1 / P1-DIMME1 / P1-DIMMF1 / P1-DIMMH1 CPU2: P2-DIMMA1 / P2-DIMMB1 / P2-DIMMD1 / P2-DIMME1 / P2-DIMMF1 / P2-DIMMH1 CPU1: P1-DIMMA1 / P1-DIMMB1 / P1-DIMMD1 / P1-DIMME1 / P1-DIMMF1 / P1-DIMMH1 CPU2: P2-DIMMA1 / P2-DIMMB1 / P2-DIMMD1 / P2-DIMME1 / P2-DIMMF1 / P2-DIMMH1
2 CPUs & 16 DIMMs	CPU1: P1-DIMMA1 / P1-DIMMB1 / P1-DIMMC1 / P1-DIMMD1 / P1-DIMME1 / P1-DIMMF1 / P1-DIMMG1 / P1-DIMMH1 CPU2: P2-DIMMA1 / P2-DIMMB1 / P2-DIMMC1 / P2-DIMMD1 / P2-DIMME1 / P2-DIMMF1 / P2-DIMMG1 / P2-DIMMH1

Front View & Interface

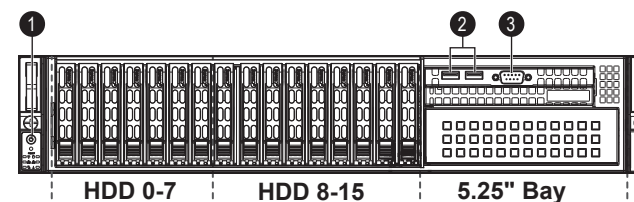

Slot	Description
0-7	2.5" hot-swap SAS3 drive bays
8-15	2.5" hot-swap SATA drive bays*

* 0-3 for optional 4x hotswap PCI-E 5.0 NVMe drives support

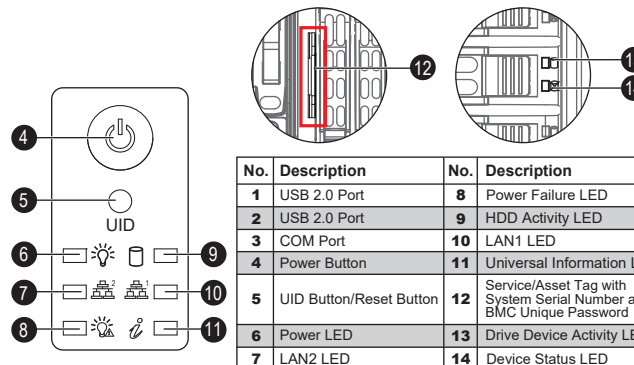

No.	Description	No.	Description
1	USB 2.0 Port	8	Power Failure LED
2	USB 2.0 Port	9	HDD Activity LED
3	COM Port	10	LAN1 LED
4	Power Button	11	Universal Information LED
5	UID Button/Reset Button	12	Service/Asset Tag with System Serial Number and BMC Unique Password
6	Power LED	13	Drive Device Activity LED
7	LAN2 LED	14	Device Status LED

No.	Description
1	SAS3 RAID with AOC-S3908L-H8IR-16DD
2	PCI-E 5.0 x16 Slot, Low Profile From CPU 1
3	PCI-E 5.0 x16 Slot, Low Profile From CPU 1
4	PCI-E 5.0 x16 Slot, Low Profile From CPU 2
5	PCI-E 5.0 x16 Slot, Low Profile From CPU 2
6	PCI-E 5.0 x8 Slot, Low Profile From CPU 2
7	UID Button (Unit Identifier Button)
8	VGA Port
9	2x LAN Ports
10	USB 0/1/2/3 Ports
11	Dedicated LAN for IPMI
12	COM Port
13	Optional 2x 2.5" drives Support
14	Redundant Power Supply Modules

System Information

Pull-out tag with BMC unique password and Serial Number Label on the left side of service tag.

Each system comes with a unique default password for the ADMIN user. This can be found on a sticker on the motherboard and a sticker on the left side of the service tag on chassis. If necessary, the password can be reset by the Supermicro IPMICFG tool.

For more information, please visit <https://www.supermicro.com/en/solutions/management-software/bmc-resources>

CPU/Heatsink Installation

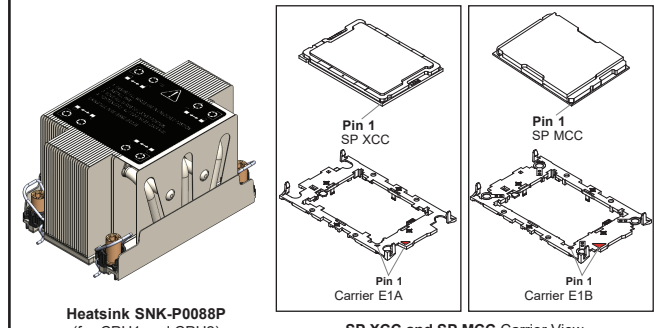
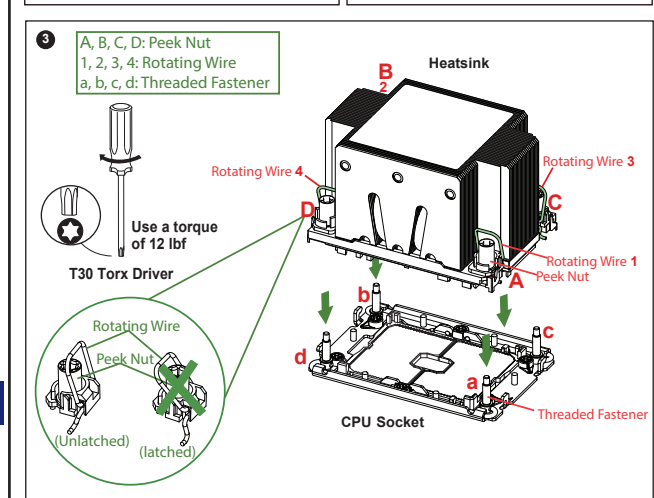
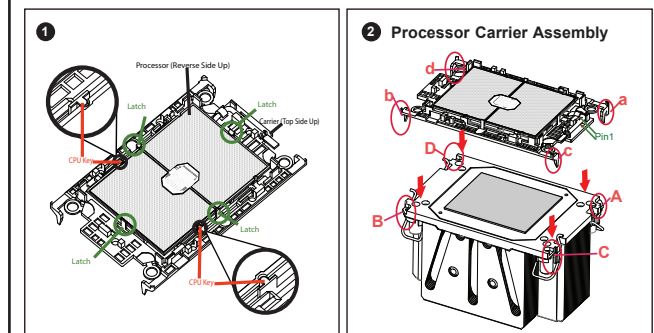

Note: Thermal grease is pre-applied on new heatsinks. No additional thermal grease is needed. CPU carrier is optional. Please select CPU carrier by CPU model. (E1A for XCC, E1B for MC)

Caution

SAFETY INFORMATION

IMPORTANT: See installation instructions and safety warning before connecting system to power supply. http://www.supermicro.com/about/policies/safety_information.cfm

WARNING

To reduce risk of electric shock/damage to equipment, disconnect power from server by disconnecting all power cords from electrical outlets. If any CPU socket empty, install protective plastic CPU cap

CAUTION

Always be sure all power supplies for this system have the same power output. If mixed power supplies are installed, the system will not operate.

For more information go to : <http://www.supermicro.com/support>