

# SUPERMICR® SuperServer 622BT-HNC8R Quick Reference Guide

## Board Layout

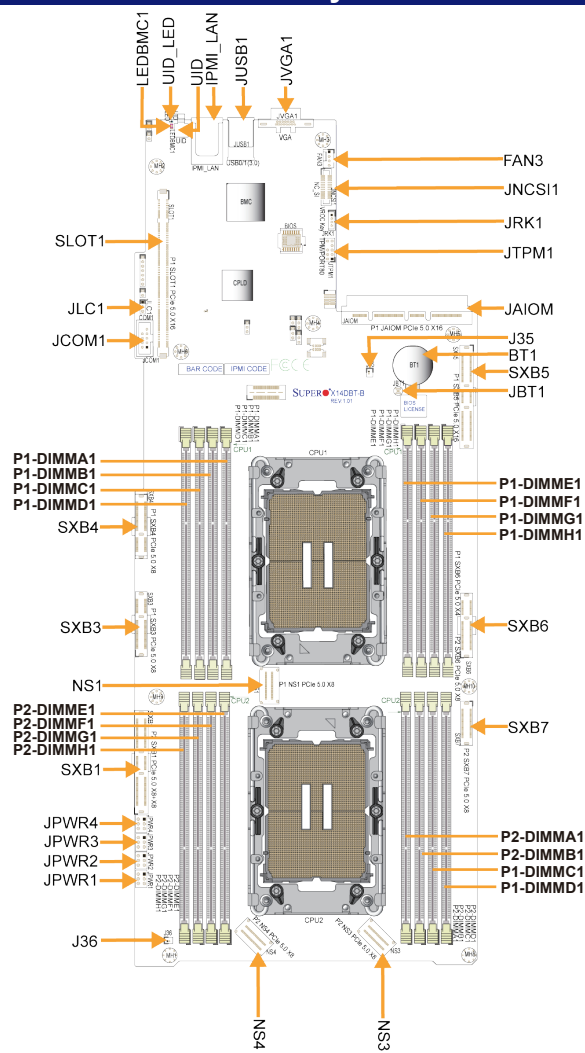

Jumper	Description	Jumper Settings (Default: Bold)
JBT1	CMOS Clear	Open (normal)

LED	Description	Status
UID_LED	Unit Identifier (UID) LED	Solid Blue: Unit Identification LED
LEDBMC	BMC Heartbeat LED	Blinking Green: BMC Normal (Active) Solid Green: (During BMC Reset or during a Cold Reboot)

Connector	Description
Battery (BT1)	Onboard Battery
COM (JCOM1)	Serial (COM) Port
Fan3	4-pin Cooling Fan Header
IPMI_LAN	Dedicated BMC LAN
J35/J36	Coolant Leakage Sensors
JAIOM1	Supermicro Advanced Input/Output Module (AIOM) PCIe 5.0 x16 connector for rear I/O support
JLC1	Cooling Leakage Sensor Header
JPWR1-JPWR4	Power Connectors
JNCSI1	NC-SI (Network Controller Sideband Interface) Connector
JTPM1	Trusted Platform Module / Port 80 Connector
NS1	NS1 PCIe 5.0 x8 connector (for NVMe SCC use) supported by Processor 1
NS3	NS1 PCIe 5.0 x8 connector (for NVMe SCC use) supported by Processor 2
NS4	NS1 PCIe 5.0 x8 connector (for NVMe SCC use) supported by Processor 2
SLOTT1	P1_SLOT1 PCIe 5.0 x16 connector supported by CPU1 with NVMe Connections 0-7
SXB1	P2_SXB1 PCIe 5.0 x8 + x8 connector supported by Processor 2
SXB3/SXB4	P1_SXB3 PCIe 5.0 x8 / SXB4 PCIe 5.0 x8 connectors supported by Processor 1
SXB5	P1_SXB5 PCIe 5.0 x16 connector supported by Processor 1
SXB6	P1_SXB6 PCIe 5.0 x4 connector supported by Processor 1 / P2_SXB6 PCIe 5.0 x8 connector supported by Processor 2
SXB7	P2_SXB7 PCIe 5.0 x8 connector supported by Processor 2
USB0/1 (3.0) (JUSB1)	Rear USB Header with support for two USB 3.0 ports
JVGA1	Backplane VGA Port
VROC RAID Key (JRK1)	Intel VROC RAID Key Header for NVMe RAID support

## Memory Support

DDR5-6400 Memory Support for the Intel® Xeon® 6700-series processors with E-cores					
Type	Ranks Per DIMM, Data Width (Stack)	DIMM Capacity (GB)			Speed (MT/s); Voltage (V); Slots per Channel (SPC) and DIMMs per Channel (DPC)
		DRAM Density			
		16 Gb	24 Gb	32 Gb	
		1DPC	1DPC	1DPC	+1.1 V
RDIMM	1Rx4	32 GB	-	-	6400, 6000, 5600, 5200, 4800 (DDR5-6400 rated RDIMMs only)
	2Rx8	32 GB	-	-	
	2Rx4	64 GB	96 GB	-	
	2Rx4	-	-	128 GB	

DDR5 Memory Population Table (2 Processors and 16 DIMMs Installed, 1DPC)	
1 Processor DIMM Counts	Memory Population Sequence (1DPC)
1 Processor and 1 DIMM	P1-DIMMA1
1 Processor and 4 DIMMs	P1-DIMMA1/P1-DIMMC1/P1-DIMME1/P1-DIMMG1 P1-DIMMB1/P1-DIMMD1/P1-DIMMH1/P1-DIMMF1
1 Processor and 8 DIMMs	P1-DIMMA1/P1-DIMMB1/P1-DIMMC1/P1-DIMMD1/P1-DIMME1/P1-DIMMF1/P1-DIMMG1/P1-DIMMH1
2 Processor DIMM Counts (Recommended)	Memory Population Sequence (1DPC)
2 Processors and 8 DIMMs	P1-DIMMA1/P1-DIMMC1/P1-DIMME1/P1-DIMMG1 P2-DIMMA1/P2-DIMMC1/P2-DIMME1/P2-DIMMG1
2 Processors and 8 DIMMs	P1-DIMMB1/P1-DIMMD1/P1-DIMMF1/P1-DIMMH1 P2-DIMMB1/P2-DIMMD1/P2-DIMMF1/P2-DIMMH1
2 Processors and 16 DIMMs	P1-DIMMA1/P1-DIMMB1/P1-DIMMC1/P1-DIMMD1/P1-DIMME1/P1-DIMMF1/P1-DIMMG1/P1-DIMMH1 P2-DIMMA1/P2-DIMMB1/P2-DIMMC1/P2-DIMMD1/P2-DIMME1/P2-DIMMF1/P2-DIMMG1/P2-DIMMH1

- Notes:**
- The memory configurations with an asterisk (\*) are recommended by Supermicro for optimal memory performance.
  - DIMMs must be all DDR5-6400 rated RDIMMs.
  - All DIMMs in a channel must have the same number of ranks (unless explicitly specified otherwise).
  - All DDR5 DIMM must be in the same speed per processor socket.
  - Mixing vendor is allowed for RDIMM.

## Air Shroud installation

### Installing the Air Shrouds

The motherboard, any expansion cards, and all components must be installed in the node tray. Place the air shroud as pictured and secure with a screw.

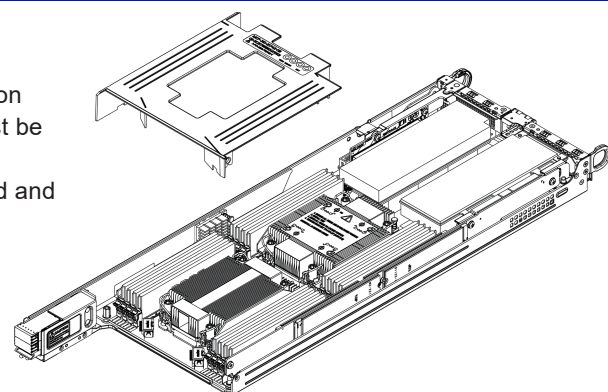

## Nodes and Corresponding Hard Drives

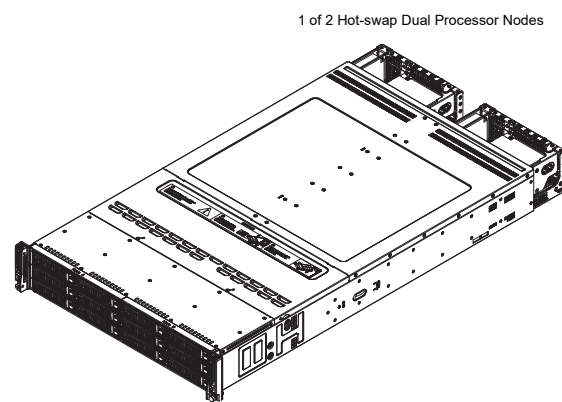

## Front view & Interface



No.	Description
1	Control Panels for Node A (bottom) and Node B (top)
2	Service Tag
3	Control Panels for Node C (bottom) and Node D (top)
4	Power Button
5	NIC LED
6	Information LED
7	BMC Button/UID LED
A-D	Drive Bays

Drive Bays (Node A-D)	
Item	Description
0-1	Two 3.5" hot-swap Gen5 (CPU1) NVMe/SAS/SATA drive bays
2	One 3.5" hot-swap Gen4 (CPU2) NVMe/SAS/SATA drive bays

## Rear View

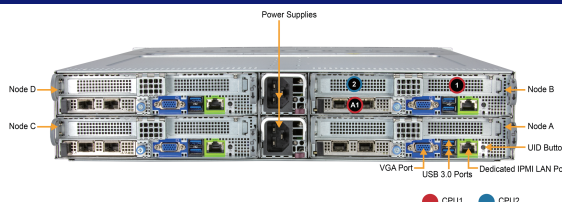

System Features: Rear	
Feature	Description
Nodes A, B, C, D	Independent computing nodes
Power Supplies	Two redundant 3000W Titanium Level power supplies
VGA Port	One video port
USB Ports	Two USB 3.1 ports
LAN Port	One dedicated BMC LAN port
Dual Function Switch	A switch that can function as either a UID LED switch or a BMC reset switch.
Node Handles	Two handles per node supporting node tray removal
A1	PCIe 5.0 x16 AIOM
1	PCIe 5.0 x16 low-profile slot
2	PCIe 5.0 x16 low-profile slot

## Heatsinks

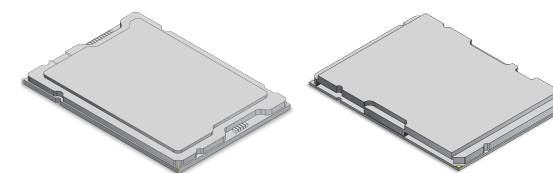

SP XCC left, SP HCC/LCC right)

## CPU Installation

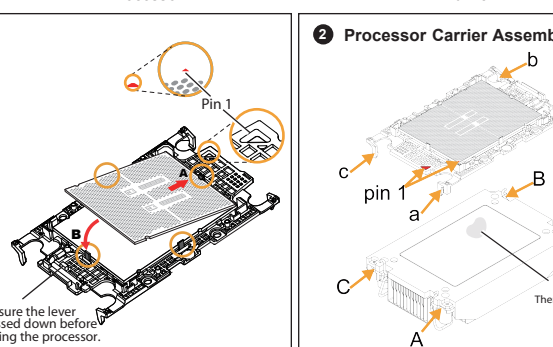
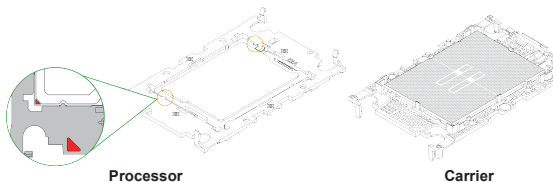

- Make sure the lever is pressed down before installing the processor.

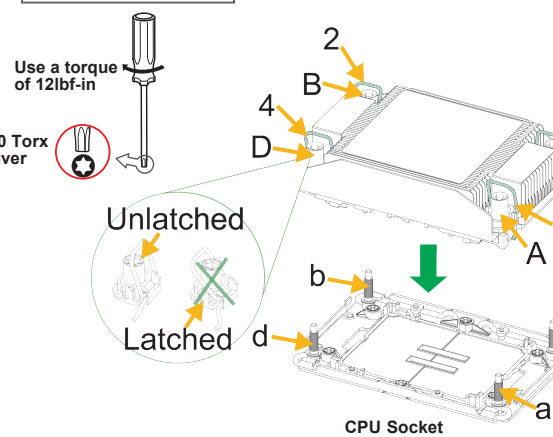

## Caution

- SAFETY INFORMATION**  
IMPORTANT: See installation instructions and safety warning before connecting system to power supply.  
[http://www.supermicro.com/about/policies/safety\\_information.cfm](http://www.supermicro.com/about/policies/safety_information.cfm)
- WARNING:**  
To reduce risk of electric shock/damage to equipment, disconnect power from server by disconnecting all power cords from electrical outlets. If any CPU socket empty, install protective plastic CPU cap
- WARNING:**  
Always be sure all power supplies for this system have the same power output. If mixed power supplies are installed, the system will not operate. For more information go to : <http://www.supermicro.com/support>

