

SUPERMICR[®] SuperServer[®] AS -2126FT-HE-LCC/ALC Quick Reference Guide

Board Layout

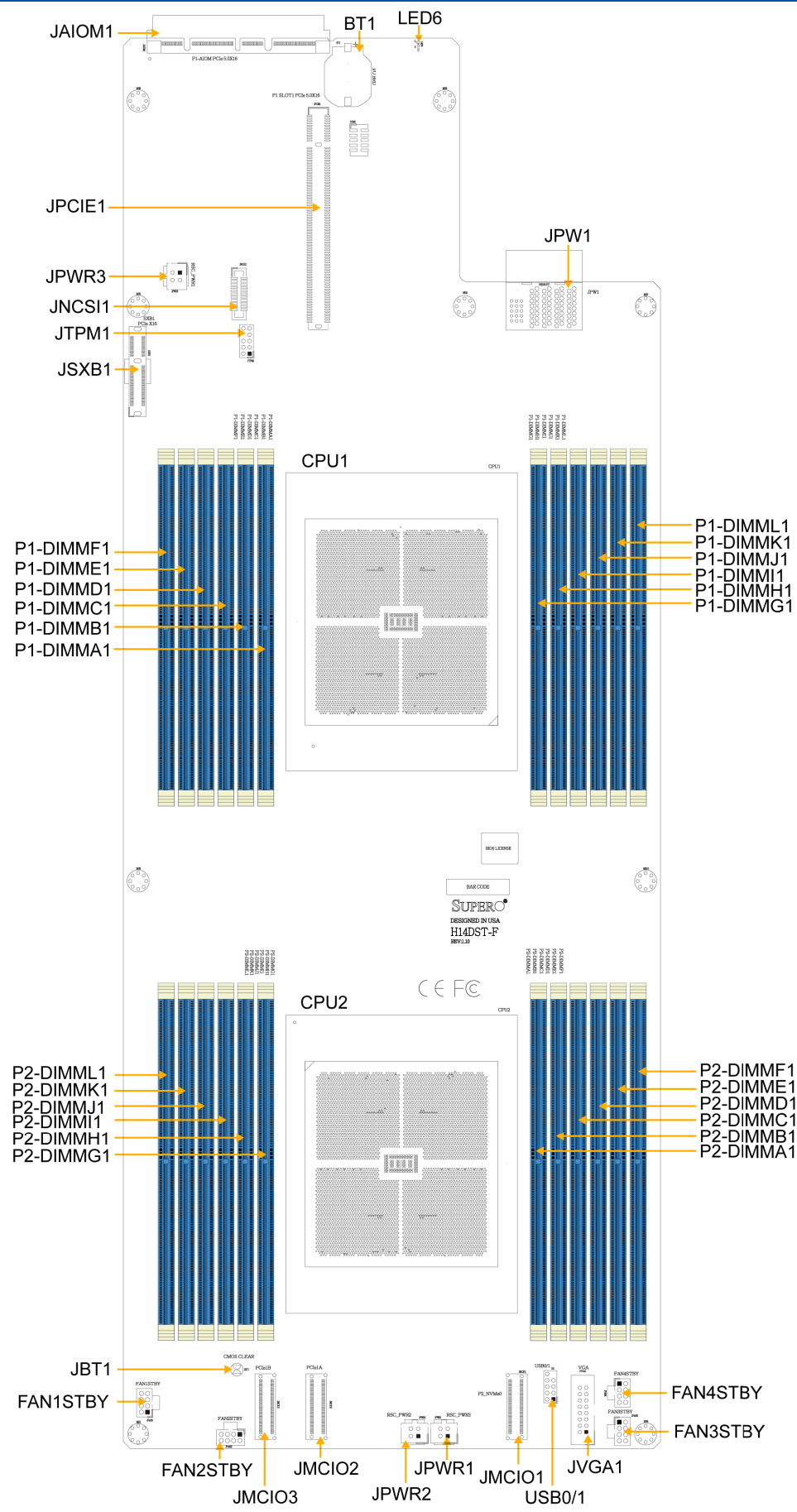

Connector	Description
BT1	Onboard Battery
FAN1STBY-FAN4STBY	8-pin Standby Fan Headers
JA1OM1	Supermicro Advanced Input/Output Module (AIOM) PCIe 5.0 x16 Connector
JMCIO1	P2_NVMe0
JMCIO2	PCIe1A
JMCIO3	PCIe1B
JNCSI1	NC-SI Connector
JPCIE1	PCIe 5.0 x16 Slot (Supermicro Proprietary FlexTwin Left Add-on Card Slot)
JPWR1	4-pin 12 V CPU Power Connector
JPWR2	4-pin 12 V CPU Power Connector
JPWR3	4-pin 12 V CPU Power Connector
JSXB1	PCIe 5.0 x8 Slot (Supermicro Proprietary FlexTwin M.2 Riser Slot)
JTPM1	Trusted Platform Module/Port 80 Connector
JVGA1	VGA Port
USB0/1 (2.0)	Front USB 2.0 Ports

Jumper	Description	Default Setting
JBT1	CMOS Clear	Open (Normal)

LED	Description	Status
LED6	Power Fail/Fan Fail LED	Red Blinking: Power Fail or Fan Fail Red Solid: Overheat

Front Features

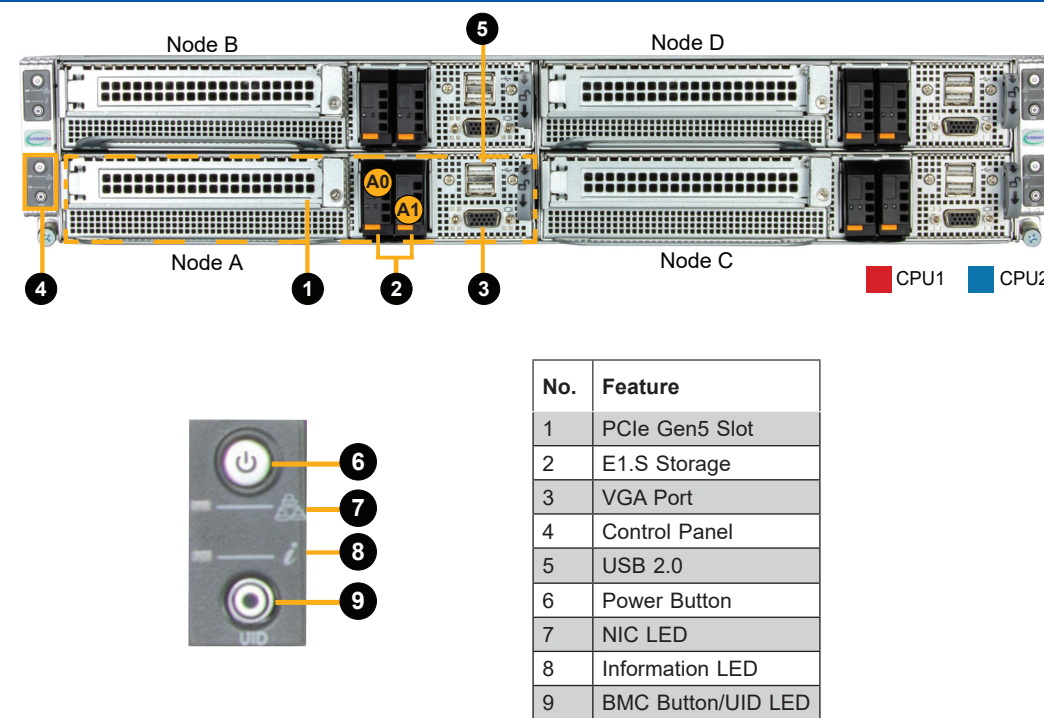

No.	Feature
1	PCIe Gen5 Slot
2	E1.S Storage
3	VGA Port
4	Control Panel
5	USB 2.0
6	Power Button
7	NIC LED
8	Information LED
9	BMC Button/UID LED

Rear Features

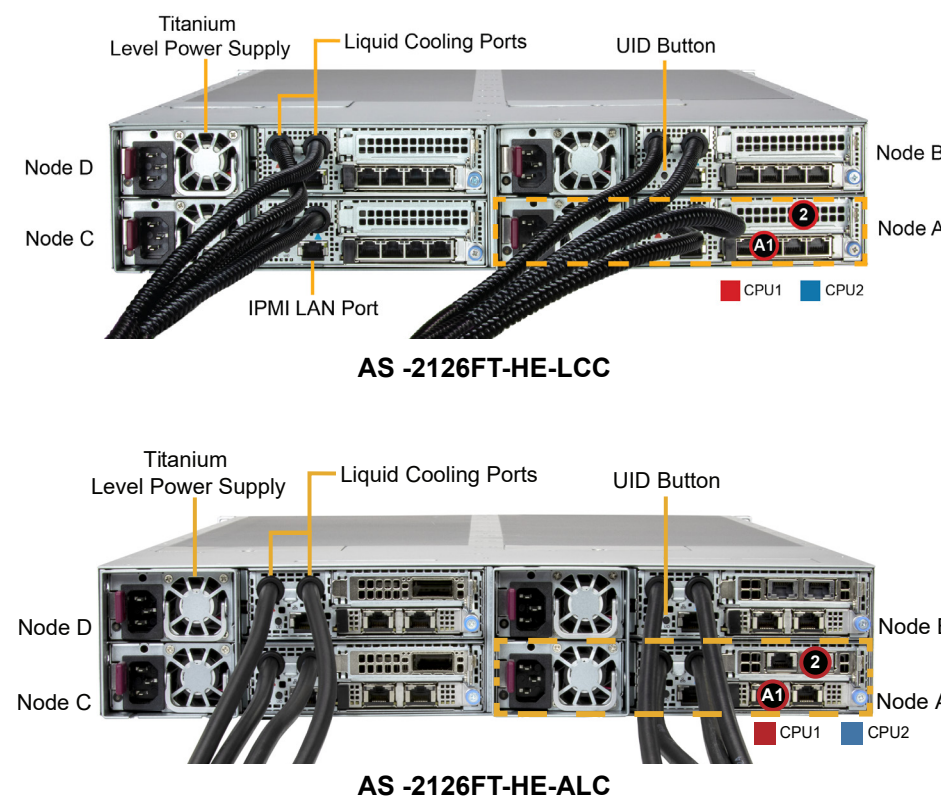

AS -2126FT-HE-LCC

AS -2126FT-HE-ALC

System Features: Rear (Per Node)

Feature	Description
A1	AIOM 5.0 x16 AIOM slot (OCP 3.0)
2	PCIe 5.0 x16 LP
Power Supply	One Titanium Level power supply module for each independent computing node
Liquid Cooling Ports	Two liquid cooling ports for each node
UID Button	One Unit ID (UID) button with LED per node
IPMI LAN Port	One IMPI LAN port for remote management per node

Power Supply Indicators

Feature	Green LED	Amber LED
No A/C Power to Power Supply	OFF	OFF
Power Supply critical events causing a shutdown/failure/OCP/OVP/Fan Fail/OTP/UV/P	OFF	ON (Steady)
Power Supply Warning Events where the power supply continues to operate: High temperature, over voltage, under voltage, etc	OFF	ON (1 Hz Blinking)
AC present only 12 VSB on (PS off)	ON (1 Hz Blinking)	OFF
Output ON and OK	ON (Steady)	OFF
AC cable unplugged and in redundant mode	OFF	ON (Steady)

Memory Support

Type		Channel											Supported Nodes per Socket (NPS)		
		F1	E1	D1	C1	B1	A1	G1	H1	I1	J1	K1		L1	
2 CPUs & 2 DIMMs	CPU1						V								NPS1
	CPU2						V								
2 CPUs & 4 DIMMs	CPU1						V	V						NPS2, NPS1	
	CPU2						V	V							
2 CPUs & 8 DIMMs	CPU1				V	V	V	V		V				NPS4, NPS2, NPS1	
	CPU2				V	V	V	V		V					
2 CPUs & 12 DIMMs	CPU1				V	V	V	V	V	V				NPS2, NPS1	
	CPU2				V	V	V	V	V	V					
2 CPUs & 16 DIMMs	CPU1	V	V	V	V	V	V	V	V	V	V			NPS4, NPS2, NPS1	
	CPU2	V	V	V	V	V	V	V	V	V	V				
2 CPUs & 20 DIMMs	CPU1	V	V	V	V	V	V	V	V	V	V	V		NPS2, NPS1	
	CPU2	V	V	V	V	V	V	V	V	V	V	V			
2 CPUs & 24 DIMMs	CPU1	V	V	V	V	V	V	V	V	V	V	V	V	NPS4, NPS2, NPS1	
	CPU2	V	V	V	V	V	V	V	V	V	V	V	V		

Note: Fully populate the motherboard with validated memory modules to achieve the best memory performance.

Removing a Node

Each of the four nodes may be removed from the main chassis. Each node is configurable on its own.

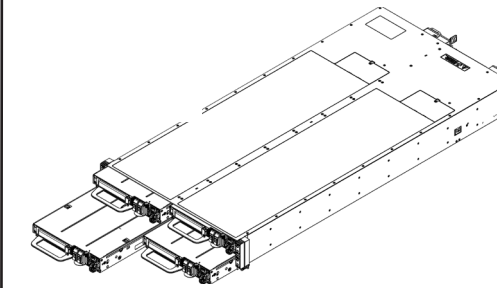

Removing Top Cover

Each node features a removable top cover, which allows easy access to the inside of the chassis.

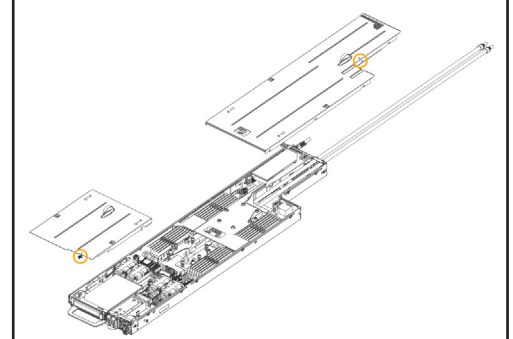

Cold Plate Torque Specification

Part and Description	Cold Plate Images
SMC CPU Liquid Cold Plate. Follow the torque settings listed on the CPU coldplate.	Torx T20 10.8-13 IN-LBF for 6 sockets
SMC by CoolIT CPU Liquid Cold Plate Follow the torque settings listed on the CPU coldplate.	Torx T20 10.8-13 IN-LBF for 6 sockets
SMC by CoolIT CPU/DIMM/VRM Liquid Cold Plate Follow the torque settings listed on the CPU coldplate and the torque settings listed on the DIMM coldplate for the DIMM +VRM coldplate.	

Product Landing Pages

AS -2126FT-HE-ALC

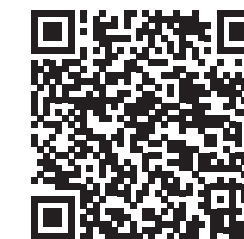

AS -2126FT-HE-LCC



System Information

Each system comes with a unique default password for the ADMIN user. This can be found on a sticker on the motherboard and another on the chassis service tag. If necessary, the password can be reset.

For more information, please visit <https://www.supermicro.com/en/solutions/management-software/bmc-resources>

SAFETY INFORMATION

IMPORTANT: See installation instructions and safety warning before connecting system to power supply.

https://www.supermicro.com/about/policies/safety_information.cfm

WARNING

To reduce risk of electric shock/damage to equipment, disconnect power from server by disconnecting all power cords from electrical outlets. If any CPU socket is empty, install protective plastic CPU cap.

CAUTION

Always be sure all power supplies for this system have the same power output. If mixed power supplies are installed, the system will not operate.

For more information, go to <https://www.supermicro.com/support>

Product drivers and utilities:

<https://www.supermicro.com> > Support > Technical Resources > Resources and Downloads