

# SUPERMICR® SuperServer SYS-E403-9D-4C/14CN/16C-FRDN13+ Quick Reference Guide

## Board Layout

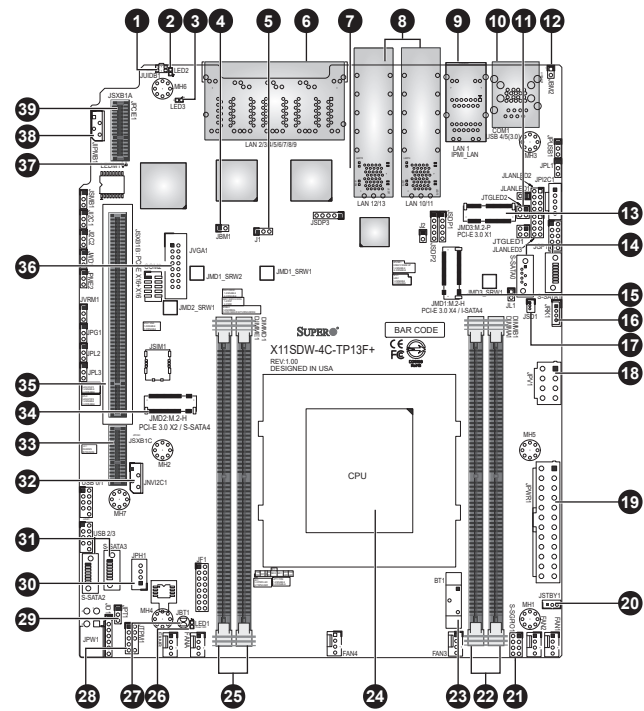

No.	Description
1	Unit Identifier Switch
2	UID LED
3	Overheat/Power Fail/Fan Fail LED
4	Disable IPMI Shared LAN
5	M.2 SMBus Enable/Disable
6	1G ALN Ports (from I350)
7	Software-Defined Pins (For I350 LAN2)
8	10 G SFP+
9	1G LAN Ports(from I210) / Dedicated IPMI LAN Port
10	COM1/USB3.1
11	LAN JBMActivity LED
12	Disable Dedicated IPMI/Shared LAN
13	M.2 Slot E-Key 2230 (USB2.0 / PCI-E x1)
14	SATA3.0
15	M.2 Slot M-Key 2280/22110 (SATA3.0 / PCI-E x4)
16	RAID Key
17	SATA DOM Power
18	12V 8-pin DC Power
19	24-pin ATX Power
20	Standby Power
21	Serial Link General Purpose I/O
22	DIMM1~DIMM1
23	Onboard Battery
24	CPU
25	DIMM1~DIMM1
26	Power LED
27	CMOS Clear
28	Trusted Platform Module (TPM)/Port 80
29	TPM Enable/Disable
30	4-pin HDD Power
31	SATA3.0 Ports
32	Non-volatile Memory (NVMe) I2C
33	WIO
34	M.2 Slot B-Key 2242/3042, PCI-E 3.0 X2 / S-SATA4
35	WIO, PCI-E X16+X16
36	VGA
37	BMC
38	System Management Bus (for IPMI only)
39	WIO

## System Features

SuperServer Model Variation Table		
SuperServer	Motherboard	Processor
E403-9D-4C-FRDN13+	X11SDW-4C-TP13F+	Intel® Xeon® D-2123IT
E403-9D-14CN-FRDN13+	X11SDW-14CN-TP13F+	Intel® Xeon® D-2177NT
E403-9D-16C-FRDN13+	X11SDW-16C-TP13F+	Intel® Xeon® D-2183IT

<b>Processors</b>	
Intel® Xeon® D-2123IT, Intel® Xeon® D-2177NT or Intel® Xeon® D-2183IT	
<b>Memory</b>	
Supports up to 256GB of ECC/non ECC RDIMM or 512GB of ECC LRDIMM DDR4 memory with speeds of up to 2667MHz (D-2177NT) in four DIMM slots	
<b>Network</b>	<b>Expansion Slots</b>
One RJ45 dedicated IPMI LAN port Four 10-GSPF+ ports Nine RJ45 GbE LAN ports	Either two PCI-E 3.0 x16 or two PCI-E 3.0 x8 + one PCI-E 3.0 x16 (FH3/4L) slots One (1) M.2 M-Key 2280/22110 (SATA3.0 / PCI-E x4) One (1) M.2 B-Key 2242/3042 (USB2.0 / USB3.0 / SATA3.0 / PCI-E x2)
<b>Motherboards</b>	<b>Input/Output</b>
X11SDW-4C-TP13F+, X11SDW-14CN-TP13F+ or X11SDW-16C-TP13F+	One (1) M.2 E-Key Slot 2230 (USB2.0 / PCI-E x1) One (1) SMC Proprietary WIO-L Slot (JSXB1A, JSXB1B, JSXB1C)
<b>Storage Drives</b>	<b>Cooling</b>
Four internal SATA3 2.5" drive bays	Four SATA3 (6Gbps) ports supporting RAID 0, 1, 5, 10 USB: two USB 3.0 ports (front), two USB 2.0 ports (front) Serial Port: one COM via RJ45 Video: one VGA port
<b>Chassis</b>	<b>Power</b>
E403iF-000NDBP2	Redundant 600W DC multi-output PFC Gold Certified power supply (PWS-601D-1R)
<b>Socket Type</b>	<b>Dimensions</b>
FCBGA2518	Compact Box 2.5U (WxHxD) 10.5 x 4.3 x 16 in. (267 x 109 x 406 mm)
<b>Chipset</b>	
Intel C621	
	<b>Three 80x80mm PWM redundant fans</b>

## Front View and Features

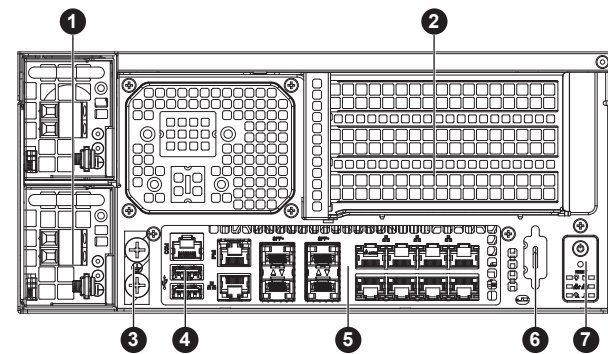

Item	Description
1	Power Input
2	PCI Slots
3	Ground
4	USB ports
5	I/O Front Panel
6	VGA Port
8	Control Panel

## Control Panel

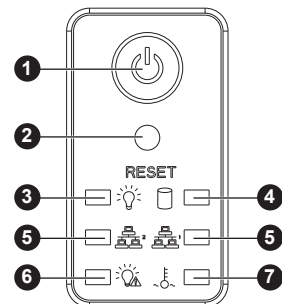

Item	Features	Description
1	Power button	The main power switch applies or removes primary power from the power supply to the server but maintains standby power.
2	Reset Button	System reset button
3	Power LED	Indicates power is being supplied to the system power supply units.
4	HDD LED	Indicates hard disk drive activity when flashing.
5	NIC LED	Indicates network activity on the LAN when flashing.
6	Information LED	Alerts operator to several states, as noted in the table on the next page.
7	Overheat LED	If this indicator is continuously on and red, an overheat condition has occurred.

  

Information LED	
Power button (1Hz)	Fan failure. Check for an inoperative fan.
Reset Button (0.25Hz)	Power failure. Check for a non-operational power supply.

## Accessing the System

### Accessing the Main System

After disconnecting power, flip open the fan cover, remove the screw that has been exposed. Slightly slide the system cover towards the fans. Lift both segments of the top cover off the chassis.

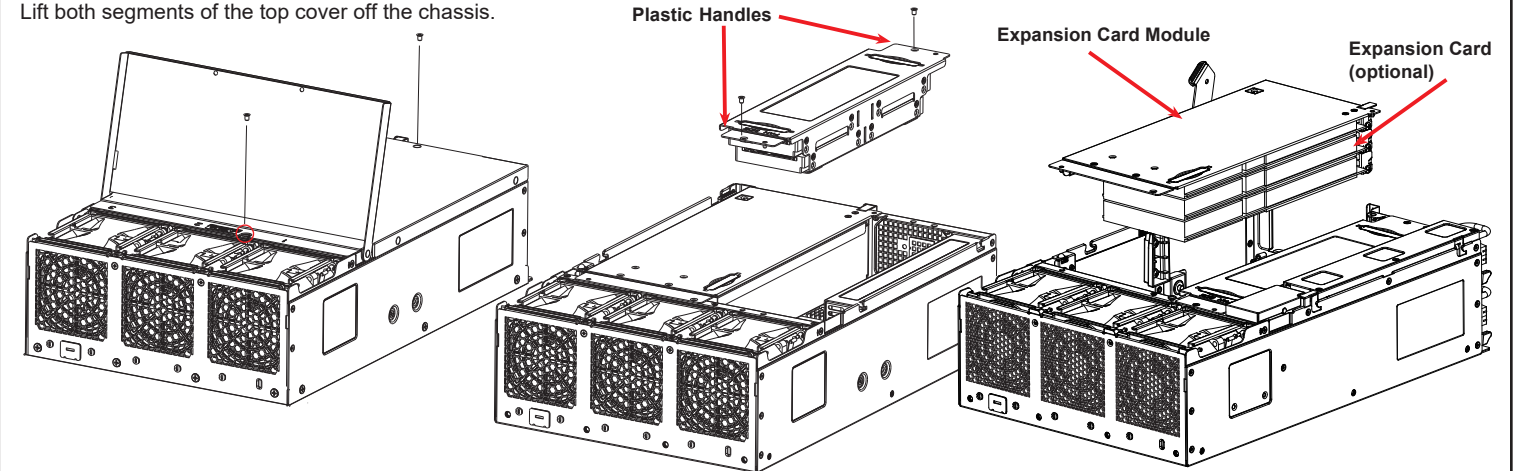

## Installing or Replacing the Riser Cards and Fans

### Components of the Expansion Card Module

The CSE-E403iF supports up to three PCI-E slots. These slots are installed on a riser car and must be installed into the system to provide expansion capability.

1. Power down the system and remove the AC power cord and the chassis cover.
2. Remove the screw as shown above and set aside.
3. Pull the locking lever up to release the expansion card module.
4. Pull the expansion card module upward with the aid of the plastic handle.

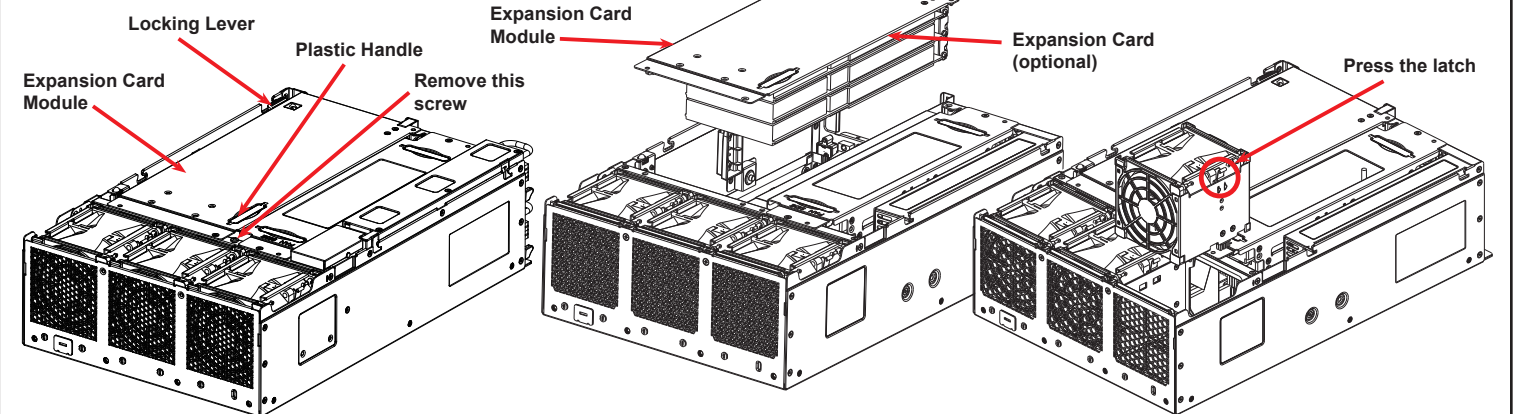

## Mounting the Chassis on the Wall

Attach the three wall mount brackets to the chassis using the ten M4xL4 screws. The mounting bracket along the I/O panel is pre-attached.

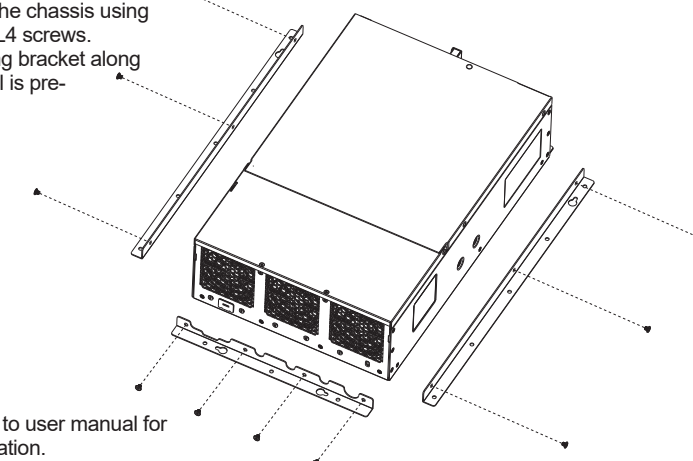

Please refer to user manual for more information.

## Caution

### SAFETY INFORMATION

**IMPORTANT:** See installation instructions and safety warning before connecting system to power supply. [http://www.supermicro.com/about/policies/safety\\_information.cfm](http://www.supermicro.com/about/policies/safety_information.cfm)

### WARNING:

To reduce risk of electric shock/damage to equipment, disconnect power from server by disconnecting all power cords from electrical outlets. If any CPU socket empty, install protective plastic CPU cap.

### WARNING:

Always be sure all power supplies for this system have the same power output. If mixed power supplies are installed, the system will not operate.

**Please clean the dust filters regularly**

For more information go to: <http://www.supermicro.com/support>

