

Board Layout

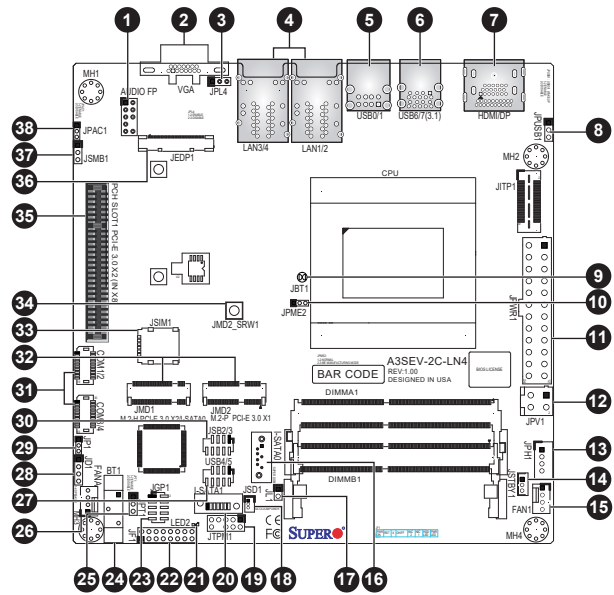

No.	Jumper & Description
1	AUDIO FP: Front Panel Audio Header
2	VGA: VGA Port
3	JPL4: LAN4 Enable/Disable (Pins 1-2 Enabled)
4	LAN 1/2/3/4: Gigabit Ethernet RJ45 Ports
5	USB 0/1: Back Panel USB 2.0 Ports
6	USB 6/7: Back Panel USB 3.1 Ports
7	HDMI/DP: High Definition Multimedia Interface/DisplayPort
8	JPUSB1: USB0/1 Wake Up (Pins 1-2 Enabled)
9	JBT1: CMOS Clear (Open: Normal)
10	JPME2: ME Manufacturing Mode (Pins 1-2 Normal)
11	JPWR1: 24-pin ATX Power Connector
12	JPV1: 4-pin 12V DC Power Connector
13	JPH1: 4-pin Power Connector (for HDD)
14	JSTBY1: Standby Power Header
15	FAN1: System Fan Headers
16	I-SATA0: SATA 3.0 Port (I-SATA0: SuperDOM)
17	JL1: Chassis Intrusion Header
18	JSD1: SATA DOM Power Connector
19	JTPM1: Trusted Platform Module (TPM)/Port80 Header
20	I-SATA1: SATA 3.0 Port (I-SATA0: SuperDOM)
21	LED2: Power LED (Solid Green: Power On)
22	JF1: Front Control Panel Header
23	JGP1: General Purpose I/O Header
24	BT1: Onboard Battery
25	JPT1: Onboard TPM Enable/Disable (Pins 2-3 Disabled)
26	FANA: System Fan Headers
27	USB 4/5: USB 2.0 Headers
28	JD1: Speaker/Buzzer (Pins 1-4: Speaker)
29	JP1: SIM Detection (Pins 1-2 High Active)
30	USB 2/3: USB 2.0 Headers
31	COM 1/2/3/4: COM Headers
32	JMD 1: M.2 B-Key 2280/3042 (PCIe 3.0 x2/SATA/USB3.1) Slot *SATA mux with I-SATA0 JMD 2: M.2 E-Key 2230 (PCIe 3.0 x1/USB2.0) Slot
33	JSIM 1: Nano SIM Card Slot
34	JMD2_SRW1: M.2 Mounting Screw
35	SLOT 1: PCH SLOT1 PCIe 3.0 x2 (in x8) Slot
36	JEDP 1: Extended DisplayPort
37	JSMB 1: System Management Bus Header
38	JPAC 1: Audio Enable/Disable (Pins 1-2 Enabled)

System Features

Motherboard	A3SEV-4C-LN4-01
Chassis	CSE-E302IL2
CPU	Intel® Atom® x6425E 4C 12W
Chipset	System on Chip
BIOS	256Mb SPI Flash with AMI BIOS®
Memory	Supports up to 32GB of in-band ECC SODIMM DDR4 with speeds of up to 3200MHz in two memory slots
Expansion Slots	One M.2 E-key (2230) (one PCIe 3.0/USB 2.0) One M.2 B-key (3042/2280) (SATA3/two PCIe 3.0/USB 3.0) One PCIe 3.0 x 2 (in x8 slot)
Storage Drives	Supports one 2.5" drive of 7mm height and one 2.5" drive of 15mm height
Power Supply	150W 12V Lockable DC Power Adapter (Optional: 180W 12V Lockable DC Power Adapter)
Input/Output Ports	One HDMI 2.0b One DP 1.4 One VGA Two USB 3.1 Gen 2 (rear), two USB 2.0 (rear), and four USB 2.0 (front) Four COM (RS-232/422/485) Four RJ45 1GbE LAN
Cooling	Fanless
Dimensions	11.6" x 2.9" x 8.1" (W x H x D) (295 x 73 x 205mm)

Caution

- SAFETY INFORMATION**
IMPORTANT: See installation instructions and safety warning before connecting system to power supply.
http://www.supermicro.com/about/policies/safety_information.cfm
- WARNING:**
To reduce risk of electric shock/damage to equipment, disconnect power from server by disconnecting all power cords from electrical outlets.
If any CPU socket empty, install protective plastic CPU cap.
- WARNING:**
Always be sure all power supplies for this system have the same power output.
If mixed power supplies are installed, the system will not operate.
- For more information go to: <http://www.supermicro.com/support>

Front View & Interface

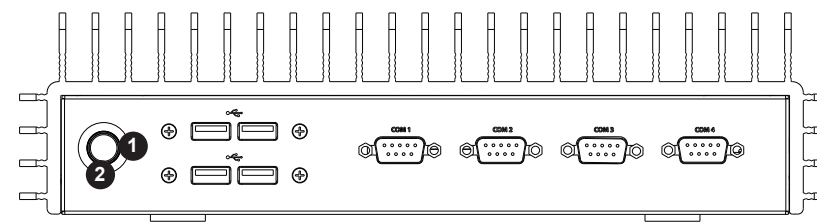

Control Panel Features

Item	Features	Description
1	Power button	The main power switch applies or removes primary power from the power supply to the server but maintains standby power. To perform most maintenance tasks, unplug the system to remove all power.
2	Power LED & HDD LED	Indicates power is being supplied to the system power supply units. This LED is illuminated when the system is operating normally. Indicates hard disk drive activity when flashing.

Rear Features

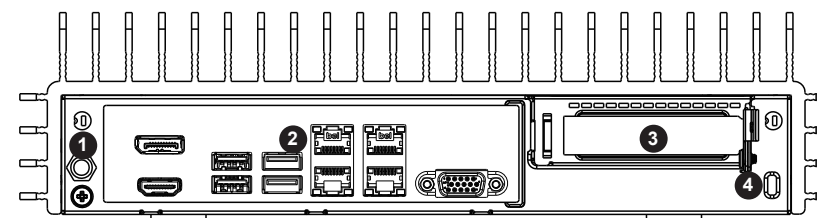

Rear Chassis Features

Item	Features	Description
1	Power input	The main power switch applies or removes primary power from the power supply to the server but maintains standby power. To perform most maintenance tasks, unplug the system to remove all power.
2	I/O ports	HDMI, DP, USB, LAN, VGA (described in Chapter 4).
3	PCI window	Standard low-profile PCIe slot (optional: may add fan to front I/O plate).
4	K-slot for lock	Accepts a standard Kensington cable locking device (not included).

Rear I/O Ports

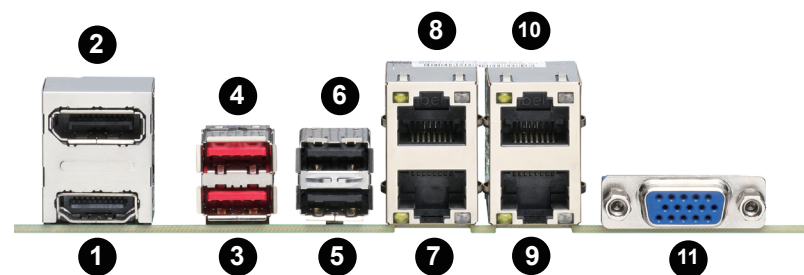

Item	Description	Item	Description	Item	Description
1	HDMI	5	USB0 (2.0)	9	LAN3
2	DP	6	USB1 (2.0)	10	LAN4
3	USB6 (3.1)	7	LAN1	11	VGA
4	USB7 (3.1)	8	LAN2		

Accessing the System

Removing the Chassis Cover Removing the Bottom Cover

- Power down the system.
- Remove the six screws that hold the cover in place.
- Lift the cover up and off the chassis.

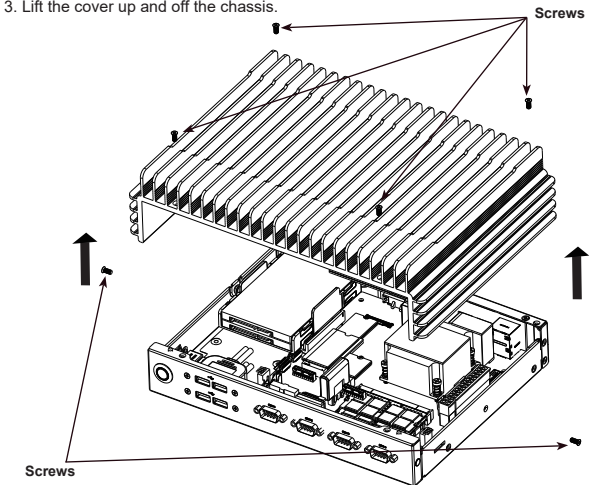

Mounting Bracket and Wall Mounting

STEP 1: Installing the Mounting Bracket

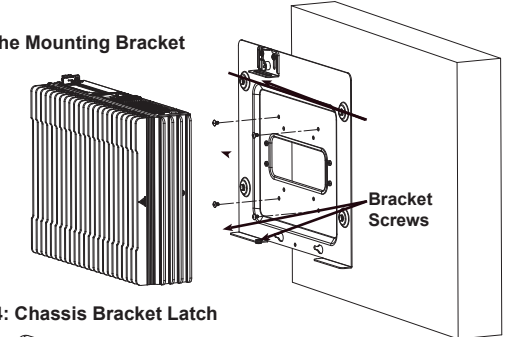

STEP 2 & 4: Chassis Bracket Latch

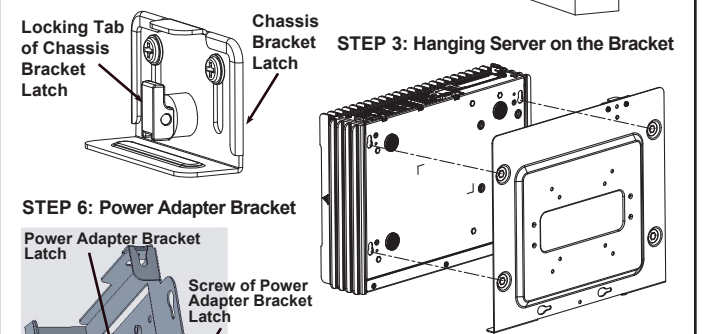

STEP 6: Power Adapter Bracket

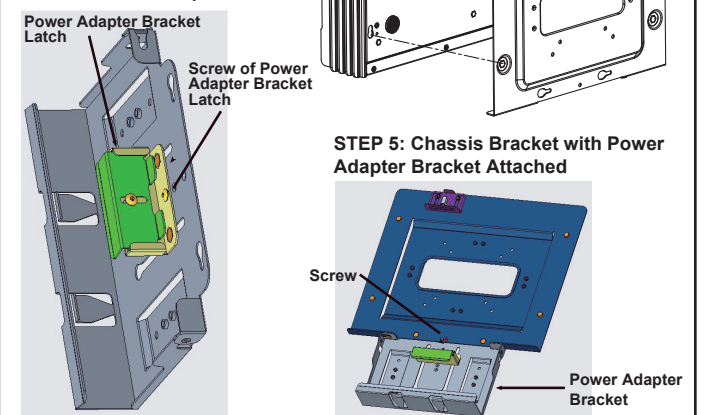

STEP 5: Chassis Bracket with Power Adapter Bracket Attached

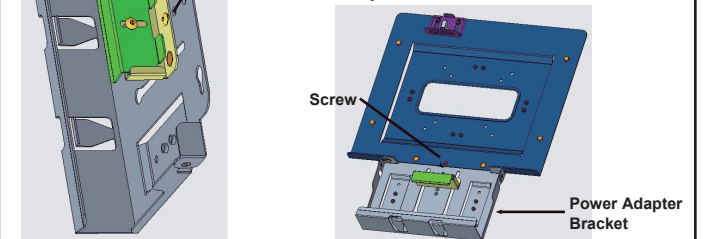

- Install the mounting bracket to the wall by using four screws.
- Unlock the latch on the top of chassis bracket and slide the latch upward.
- Hang the server system on the mounting bracket hooking the four keyholes on four knobs of the bracket.
- Secure the server system to the bracket by sliding the latch back down and flipping tab to lock.
- Additional power adapter bracket on the bottom of the chassis bracket.
- Secure the power adapter by lowering the latch and tightening the screw.

