

# SUPERMICR® SuperServer 5029C-TN2 Quick Reference Guide

## Board Layout

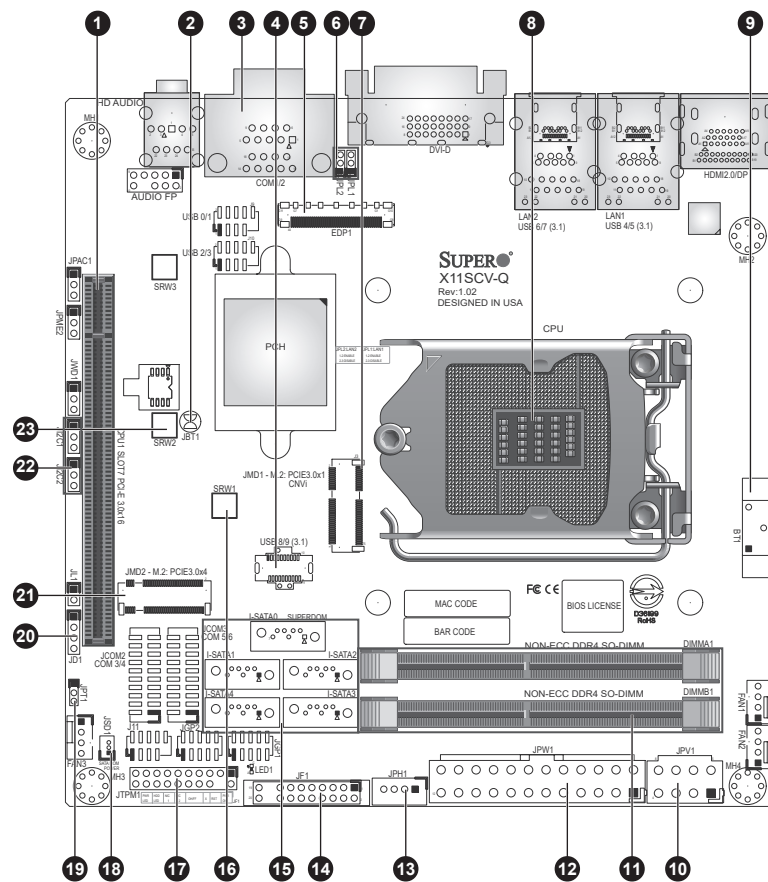

No.	Description
1	CPU PCI-E 3.0 x16 Slot
2	CMOS Clear
3	COM Ports
4	Front Accessible USB Header (Two USB 3.1 Type A)
5	Embedded Display Port
6	LAN1, LAN2 Enable/Disable
7	M.2 PCI-E 3.0 x1 CNVi Slot (E Key 2230)
8	CPU
9	Onboard CMOS battery
10	12V 8-pin DC Power Connector
11	DIMMA1~DIMMB1
12	24-pin ATX Power Connector
13	4-pin Power Connector for HDD use
14	Front Control Panel Header
15	I-SATA0~I-SATA4 Intel SATA 3.0 Ports
16	M.2 Mounting Screws
17	Trusted Platform Module/Port 80 Connector
18	SATA DOM Power Connector
19	TPM Enable/Disable
20	Speaker/Buzzer (Pins 1-4: Speaker)
21	M.2 PCI-E 3.0 x4 Slot (M Key 2242/2280)
22	SMB to PCI-E Slots Enable/Disable
23	M.2 Mounting Screws

## Rear I/O Ports

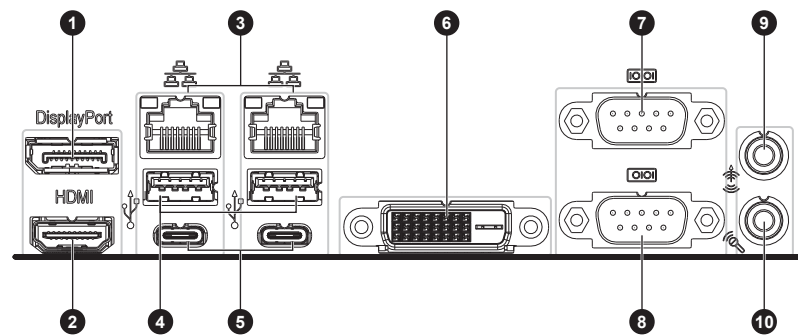

No.	Description	No.	Description
1	DP Port	6	DVI-D
2	HDMI Port	7	COM2
3	LAN Ports	8	COM1
4	USB Ports (3.1 Type A)	9	Line Out
5	USB Ports (3.1 Type C)	10	Mic In

## System Features

<b>Motherboard</b>	X11SCV-Q
<b>Chassis</b>	Mini Tower, SC721TQ-250B
<b>CPU</b>	Intel 8th Generation Core i7/i5/i3 (System on a Chip) in the LGA1151 format.
<b>Chipset</b>	Intel Q370/H310
<b>Fan</b>	One 12-cm rear exhaust fan
<b>Memory</b>	Up to 32GB of DDR4 Non-ECC SO-DIMM with speeds of up to 2666MHz in two slots*
<b>Expansion Slots</b>	One (1) M.2 PCI-E 3.0 x1 CNVi Slot (E Key 2230) One (1) M.2 PCI-E 3.0 x4 Slot (M Key 2242/2280) One (1) PCI-E 3.0 x16 Slot
<b>Hard Drives</b>	Four 3.5" hot-swap drive bays Two internal fixed 2.5" hard drive bays (DVD-ROM as an option in the top 2.5" bay)
<b>Power</b>	One 250W flex ATX power supply
<b>Dimensions</b>	Width 8.27" (210mm), Height 9.45" (240mm), Depth 11" (279mm)

## Front View & Interface

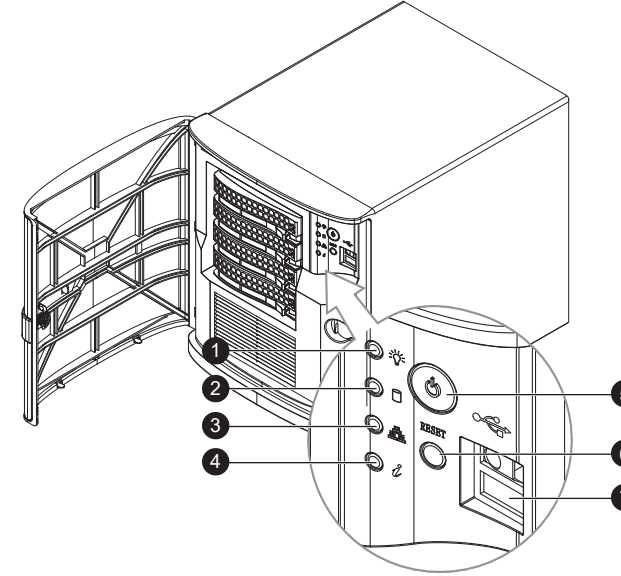

No.	Description	Information LED	
		Status	Description
1	Power LED	Continuously on and red	An overheat condition has occurred. (This may be caused by cable congestion.)
2	HDD LED		
3	NIC LED		
4	Information LED	Blinking red (1Hz)	Fan failure, check for an inoperative fan.
5	Power Button		
6	Reset Button		
7	USB 2.0		

## Beep (POST) Codes

BIOS Beep (POST) Codes	
Beep Code	Description
1 beep	C ircuitry has been reset (Ready to power up)
5 short, 1 long	No memory detected in system
5 long, 2 short	Video adapter missing or with faulty memory
1 long continuous	System overheat condition

## Caution

- SAFETY INFORMATION**  
IMPORTANT: See installation instructions and safety warning before connecting system to power supply.  
[http://www.supermicro.com/about/policies/safety\\_information.cfm](http://www.supermicro.com/about/policies/safety_information.cfm)
- WARNING:**  
To reduce risk of electric shock/damage to equipment, disconnect power from server by disconnecting all power cords from electrical outlets.  
If any CPU socket empty, install protective plastic CPU cap.
- WARNING:**  
Always be sure all power supplies for this system have the same power output. If mixed power supplies are installed, the system will not operate.  
For more information go to: <http://www.supermicro.com/support>

## Drive Device Bays

### Removing 3.5" Hot-Swap Hard Drives

1. Unlock the front bezel and swing it open.
2. Press the release tab on the hard drive carrier; this will extend the hard drive carrier handle.
3. Use the handle to pull the hard drive out of the chassis.

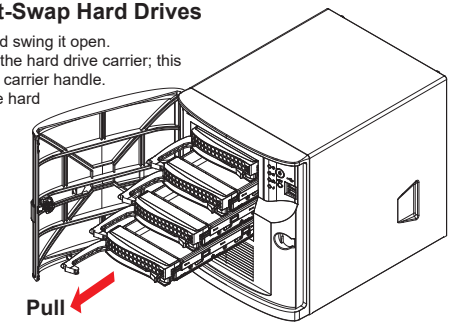

### Installing a Hard Drive into a Drive Carrier

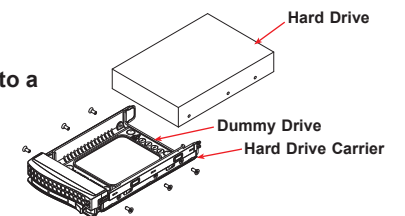

### Installing a Drive Carrier into the Hard Drive Cage

1. Insert the hard drive carrier into the drive bay, using the drive carrier handle to push it all the way into the hard drive cage until it stops.
2. Close the handle until the drive carrier clicks into the locked position.
3. Close and lock the front bezel.

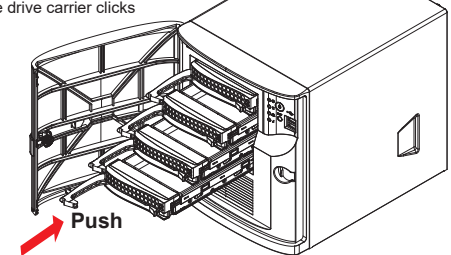

### Installing a Top-Mounted Fixed Hard Drive

1. Power down the system and remove the chassis cover.
2. Place a 2.5" hard drive into the hard drive bracket and secure the drive to the bracket with the four screws provided.
3. Place the hard drive and bracket into the top mounting position of the chassis as illustrated below and secure it to the chassis with two screws.
4. Replace the chassis cover, plug the power cord into the rear of the power supply and power up the system.

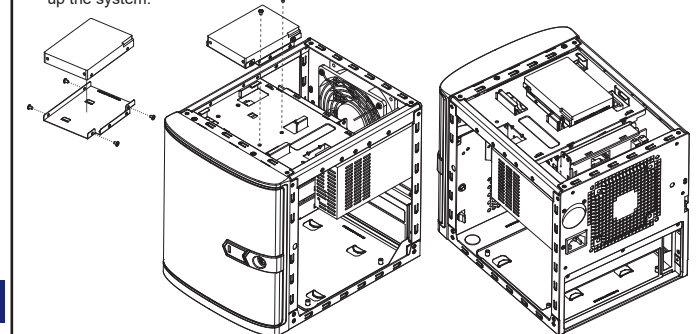

### Installing a Side-Mounted Fixed Hard Drive

1. Power down the system and remove the chassis cover.
2. Place a 2.5" hard drive into the hard drive bracket and secure the hard drive to the bracket with the four screws provided.
3. Place the hard drive and bracket into the side mounting position of the chassis by inserting the pin on the bracket into the mounting hole on the chassis as illustrated below.
4. Replace the chassis cover, plug the power cord into the rear of the power supply and power up the system.

