

Board Layout

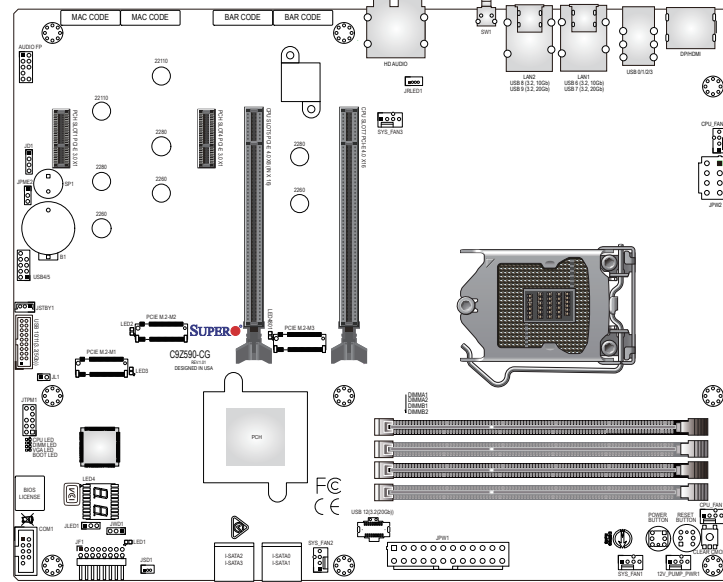

Jumper	Description	Default Setting
CLEAR CMOS	Clear CMOS Switch	Push Button Switch
JD1	Speaker / Buzzer	Pins 1-4: External Speaker Pins 3-4: Buzzer
JPME2	Intel Manufacturing Mode	Pins 1-2: Normal Pins 2-3: Manufacturing Mode
JWD1	Watch Dog Function Enable	Pins 1-2: RST Pins 2-3: NMI
POWER BUTTON	Internal Power Button	Push Button Switch
RESET BUTTON	Onboard System Reset Button	Push Button Switch
SW1	Back Panel Clear CMOS Switch	Push Button Switch
Connector	Description	
CPU_FAN1 ~ CPU_FAN2	CPU Fan Headers	
CPU SLOT5 PCI-E 4.0 x8 (IN x16)	PCIe 4.0 x16 Slot (PCIe 4.0 x8 Link)	
CPU SLOT7 PCI-E 4.0 x16	PCIe 4.0 x16 Slot (PCIe 4.0 x16 Link)	
DP/HDMI	Back Panel DisplayPort/High Definition Multimedia Interface	
HD AUDIO	High Definition Audio Ports	
I-SATA0~3	(Intel Z590) Serial ATA (SATA 3.0) Ports 0~3 (6Gb/sec)	
JF1	Front Control Panel Header	
JL1	Chassis Intrusion Header	
JLED1	Power LED Indicator Header	
JPW1	24-pin ATX Main Power Connector (Required)	
JPW2	+12V 8-pin CPU Power Connector (Required)	
JRLED1	4-pin Connector for a White Light LED Board (Pre-installed) Inside the I/O cover	
JSD1	SATA DOM (Disk-On-Module) Power Connector	
JSTBY1	5V Standby Power Header	
JTPM1	Trusted Platform Module (TPM)/Port 80 Header (Supports TPM 2.0 only)	
LAN1/LAN2	RJ45 1GbE/10GbE LAN Ports	
PCI-E M.2-M1/M2	PCIe 3.0 x4 M.2 M-Key Sockets (Attached to PCH)	
PCI-E M.2-M3	PCIe 4.0 x4 M.2 M-Key Socket (Attached to CPU)	
PCH SLOT1/4 PCI-E 3.0 x1	PCIe 3.0 x1 Slots (PCIe 3.0 x1 Link)	
SP1	Internal Speaker/Buzzer	
SYS_FAN1 ~ SYS_FAN3	System Fan Headers	
USB 0/1/2/3	Back Panel USB 2.0 Ports (Type A)	
USB 4/5	Front Panel Accessible USB 2.0 Header	
USB 6	Back Panel USB 3.2 Gen 2 Port (10Gb, Type A)	
USB 7	Back Panel USB 3.2 Gen 2x2 Port (20Gb, Type C)	
USB 8	Back Panel USB 3.2 Gen 2 Port (10Gb, Type A)	
USB 9	Back Panel USB 3.2 Gen 2x2 Port (20Gb, Type C)	
USB 10/11	Front Panel Accessible USB 3.2 Gen 1 Header (5Gb)	
USB 12	Front Panel Accessible USB 3.2 Gen 2x2 20-pin Connector (20Gb)	

Memory

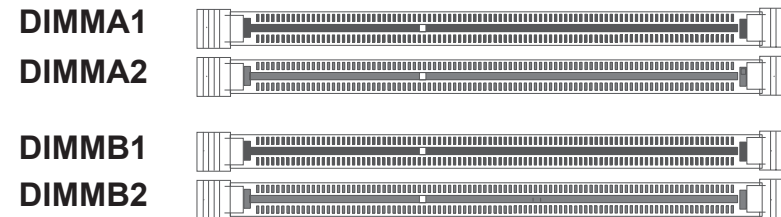

General Guidelines for Optimizing Memory Performance

When installing memory modules, the DIMM slots should be populated in the following order: DIMMA2, DIMMB2, then DIMMA1, DIMMB1

- Always use DDR4 DIMM modules of the same size, type and speed.
- Mixed DIMM speeds can be installed. However, all DIMMs will run at the speed of the slowest DIMM.
- For optimal performance, use DDR4 memory of the same type, size and speed.
- The motherboard will support odd-numbered modules (one or three modules installed). However, to achieve the best memory performance, a balanced memory population is recommended.

Heatsink Installation

Installing an Active CPU Heatsink with Fan

1. Apply the proper amount of thermal grease to the heatsink.
2. Place the heatsink on top of the CPU so that the four mounting holes on the heatsink are aligned with those on the retention mechanism.
3. Tighten the screws in the following order:

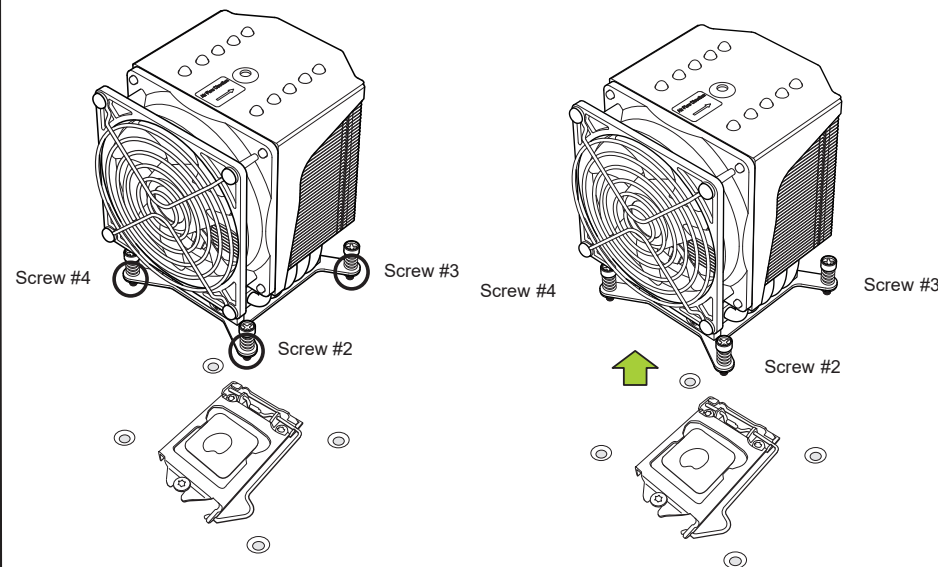

4. Once the screws are tightened, plug the power connector of cooler into either CPU_FAN1 or CPU_FAN2 header.

Removing an Active CPU Heatsink with Fan

1. Unplug the power cord from the power supply and power connector of cooler from fan header on the motherboard.
2. Loosen the screws in the order below.
3. Gently wiggle the heatsink to loosen it. Do not use excessive force when wiggling the heatsink.

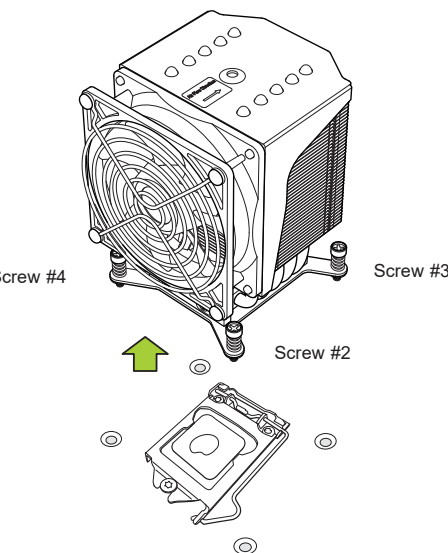

4. Once the heatsink is loosened, remove it from the motherboard.

Hard Drives Installation

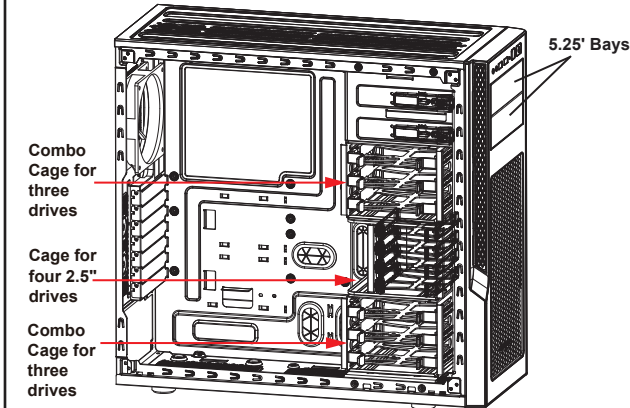

Removing and Installing 3.5"/2.5" Hard Drives

1. Open the chassis left side cover.
2. Remove the drive mounting bracket from the cage. Pinch the tabs and pull out.
3. Secure the drive into the mounting bracket by flexing the drive bracket and drop the drive in with the connector side facing into the chassis.
4. Slide the assembly into the cage.
5. Connect the storage device cables from the motherboard.

Rear I/O Ports

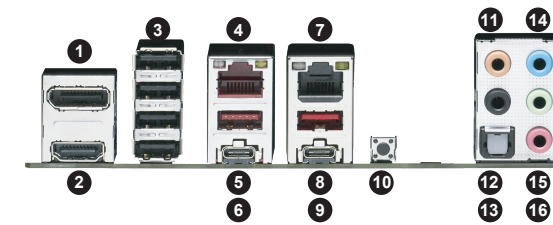

#	Description
1	DisplayPort 1.4a
2	HDMI Port 2.0b
3	USB0/1/2/3: USB 2.0 (Type A)
4	Ethernet RJ45 1GbE Port 1
5	USB6: USB 3.2 Gen 2 (10Gb, Type A)
6	USB7: USB 3.2 Gen 2x2 (20Gb, Type C)
7	Ethernet RJ45 10GbE Port 2
8	USB8: USB 3.2 Gen 2 (10Gb, Type A)
9	USB9: USB 3.2 Gen 2x2 (20Gb, Type C)
10	SW1: CLEAR CMOS
11	Center/LFE Out
12	Surround Out
13	S/PDIF Out
14	Line In
15	Line Out
16	Mic In

Installing an Optical Device

Installing an Optical Device

1. Open the chassis left side cover.
2. Locate and press the release tab for the drive tray where you want to place the DVD drive.
3. Push the drive tray toward the front of the chassis and out.
4. Slide the DVD drive into the chassis until it clicks into place.

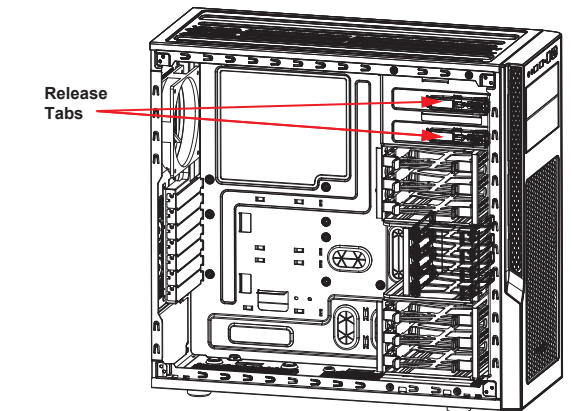

CPU Installation

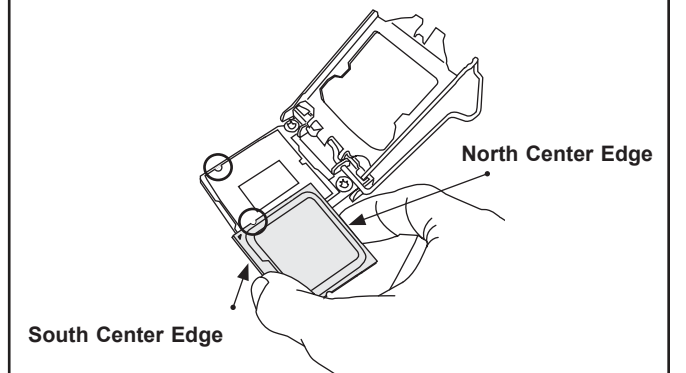

Caution

SAFETY INFORMATION
IMPORTANT: See installation instructions and safety warning before connecting system to power supply.
http://www.supermicro.com/about/policies/safety_information.cfm

WARNING:
To reduce risk of electric shock/damage to equipment, disconnect power from server by disconnecting all power cords from electrical outlets.
If any CPU socket empty, install protective plastic CPU cap

CAUTION:
Always be sure all power supplies for this system have the same power output. If mixed power supplies are installed, the system will not operate.

For more information go to <http://www.supermicro.com/support>

