

SUPERMICR® SuperWorkstation 530T-I Quick Reference Guide

Board Layout

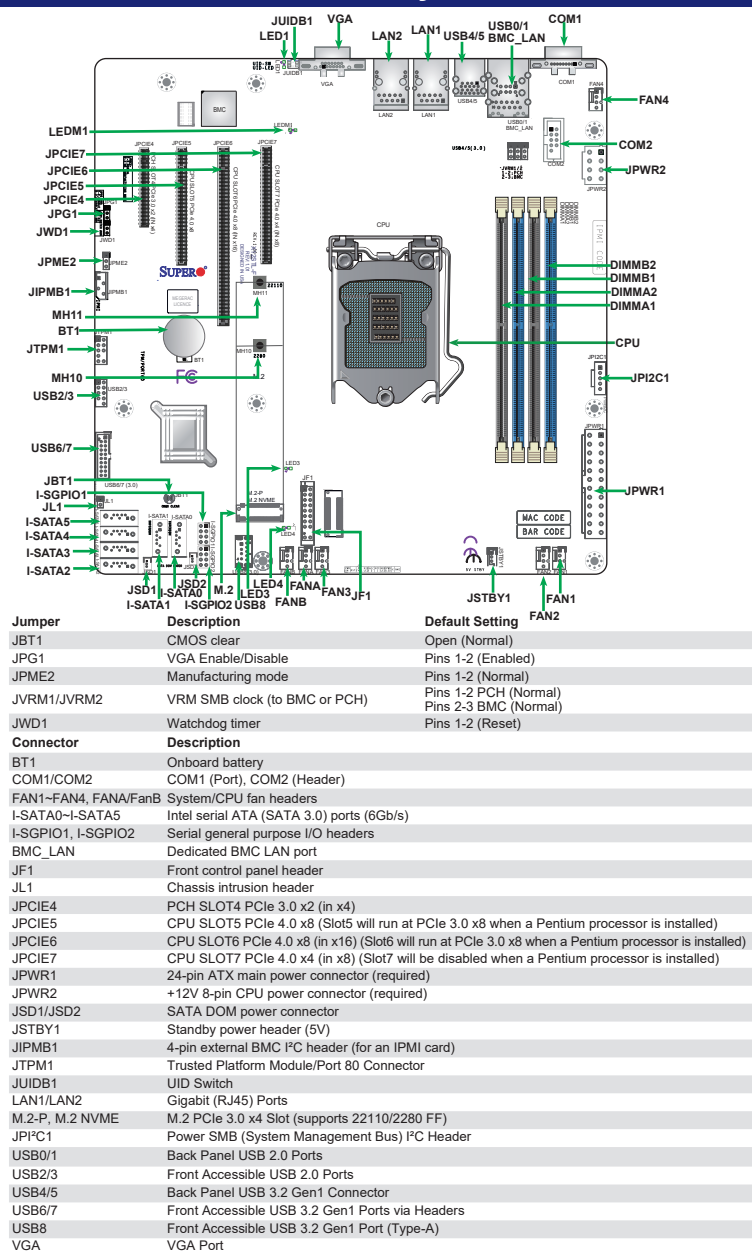

Jumper	Description	Default Setting
JBT1	CMOS clear	Open (Normal)
JPG1	VGA Enable/Disable	Pins 1-2 (Enabled)
JPME2	Manufacturing mode	Pins 1-2 (Normal)
JVRM1/JVRM2	VRM SMB clock (to BMC or PCH)	Pins 1-2 PCH (Normal) Pins 2-3 BMC (Normal)
JWD1	Watchdog timer	Pins 1-2 (Reset)

Connector	Description
BT1	Onboard battery
COM1/COM2	COM1 (Port), COM2 (Header)
FAN1-FAN4, FANA/FanB	System/CPU fan headers
I-SATA0-I-SATA5	Intel serial ATA (SATA 3.0) ports (6Gb/s)
I-SGPI01, I-SGPI02	Serial general purpose I/O headers
BMC_LAN	Dedicated BMC LAN port
JF1	Front control panel header
JL1	Chassis intrusion header
JPCIE4	PCH SLOT4 PCIe 3.0 x2 (in x4)
JPCIE5	CPU SLOTS5 PCIe 4.0 x8 (Slot5 will run at PCIe 3.0 x8 when a Pentium processor is installed)
JPCIE6	CPU SLOTS6 PCIe 4.0 x8 (in x16) (Slot6 will run at PCIe 3.0 x8 when a Pentium processor is installed)
JPCIE7	CPU SLOTS7 PCIe 4.0 x4 (in x8) (Slot7 will be disabled when a Pentium processor is installed)
JPWR1	24-pin ATX main power connector (required)
JPWR2	+12V 8-pin CPU power connector (required)
JSD1/JSD2	SATA DOM power connector
JSTBY1	Standby power header (5V)
JIPMB1	4-pin external BMC I/O header (for an IPMI card)
JTPM1	Trusted Platform Module/Port 80 Connector
JUIDB1	UID Switch
LAN1/LAN2	Gigabit (RJ45) Ports
M.2-P, M.2 NVME	M.2 PCIe 3.0 x4 Slot (supports 22110/2280 FF)
JPIC1	Power SMB (System Management Bus) I/O Header
USB0/1	Back Panel USB 2.0 Ports
USB2/3	Front Accessible USB 2.0 Ports
USB4/5	Back Panel USB 3.2 Gen1 Connector
USB6/7	Front Accessible USB 3.2 Gen1 Ports via Headers
USB8	Front Accessible USB 3.2 Gen1 Port (Type-A)
VGA	VGA Port

Back Panel I/O Connectors

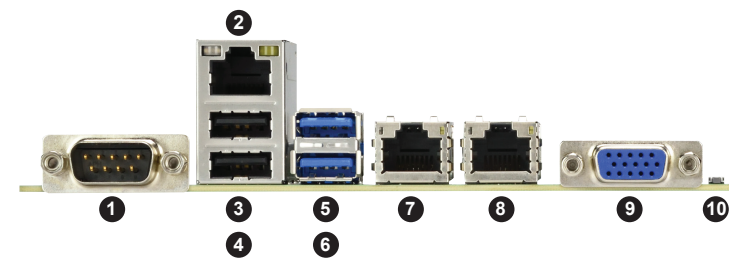

No.	Description	No.	Description
1	COM1	6	USB6 (USB 3.2 Gen 1)
2	Dedicated IPMI LAN	7	LAN1
3	USB1	8	LAN2
4	USB0	9	VGA Port
5	USB5 (USB 3.2 Gen 1)	10	UID Switch

Memory

DIMM Installation

1. Insert the desired number of DIMMs into the slots based on the recommended DIMM population tables shown above.
2. Push the release tabs on both ends of the DIMM slot outwards to unlock it.
3. Align the key of the DIMM module with the receptive point on the memory slot.
4. Align the notches on both ends of the module with the receptive points on the ends of the slot.
5. Push both ends of the module straight down into the slot until the module snaps into place.
6. Press the release tabs to the lock positions to secure the DIMM module into the slot.

Recommended Population (Balanced)				
DIMMA1	DIMMB1	DIMMA2	DIMMB2	Total System Memory
		4GB	4GB	8GB
4GB	4GB	4GB	4GB	16GB
		8GB	8GB	16GB
8GB	8GB	8GB	8GB	32GB
		16GB	16GB	32GB
16GB	16GB	16GB	16GB	64GB
		32GB	32GB	64GB
32GB	32GB	32GB	32GB	128GB

↑ Towards the CPU

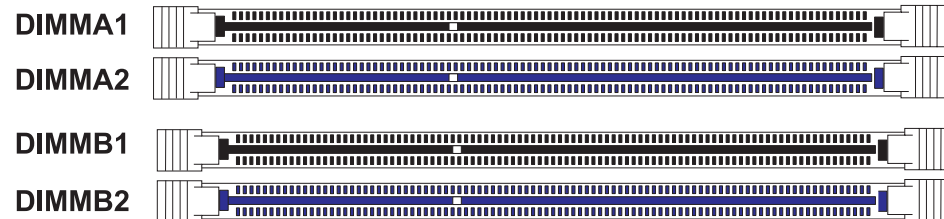

Heatsink Installation

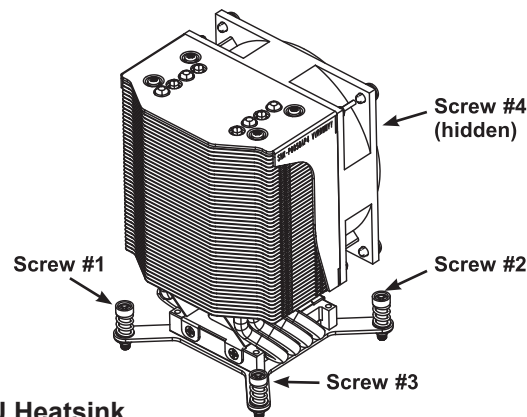

Installing the CPU Heatsink

Do not apply thermal grease to the heatsink or the CPU-the required amount has already been applied

1. Remove the power cord from the system.
2. Place the heatsink on top of the CPU so that the four mounting screws on the heatsink are aligned with holes on the socket.
3. Tighten the screws in the order noted below, evenly and gradually. Do not over-tighten.
4. Connect the heatsink fan wires to the proper motherboard connector.

Front View & Interface

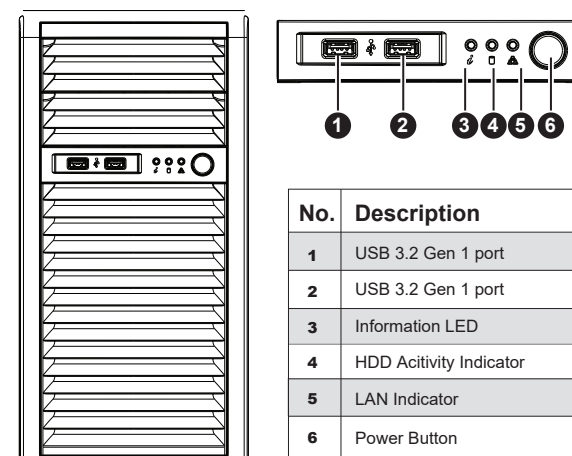

No.	Description
1	USB 3.2 Gen 1 port
2	USB 3.2 Gen 1 port
3	Information LED
4	HDD Activity Indicator
5	LAN Indicator
6	Power Button

CPU Installation

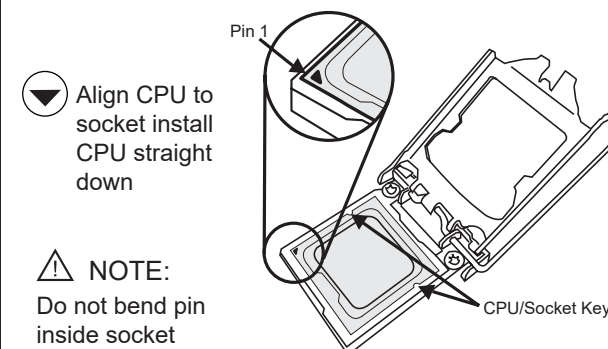

Hard Drives Installation

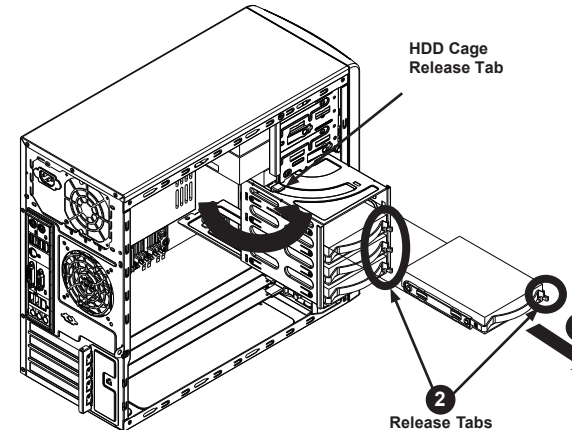

Removing and Installation 3.5" Hard Drives

1. Disconnect the chassis from any power source.
2. Rotate the hard drive cage outward 90 degrees.
3. Disconnect all of the cables from the hard drive.
4. Press the release tab on the side of the hard drive carrier that is to be removed from the hard drive cage.
5. Gently slide the hard drive carrier out of the hard drive cage.

Installing an Optical Device

Begin by removing power from the system

1. Remove the front bezel from the chassis by lifting it upwards from the bottom and pulling off the front of the chassis.
2. Remove the cover plate from the optical device slot on the front of the chassis.
3. Install the bracket rail (A) onto one side of the device by inserting the pins of the bracket into the mounting holes on the side of the device.
4. Slide the device into the chassis.
5. If desired, screws may be used to secure the device into chassis.
6. Attach the power and data cables to the drive.
7. Replace the chassis cover before restoring power to the system.

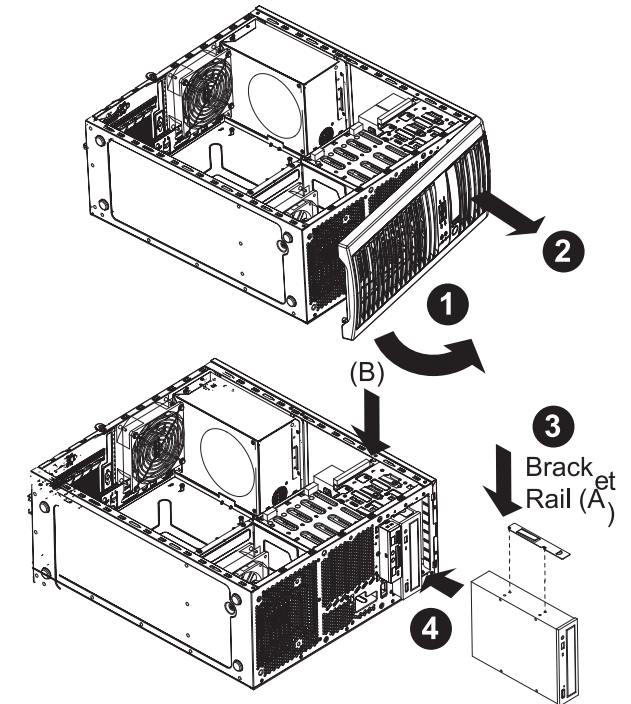

Caution

SAFETY INFORMATION

IMPORTANT: See installation instructions and safety warning before connecting system to power supply. http://www.supermicro.com/about/policies/safety_information.cfm

WARNING:

To reduce risk of electric shock/damage to equipment, disconnect power from server by disconnecting all power cords from electrical outlets. If any CPU socket empty, install protective plastic CPU cap

CAUTION:

Always be sure all power supplies for this system have the same power output. If mixed power supplies are installed, the system will not operate.

WARNING:

This product can expose you to chemicals including lead, known to the State of California to cause cancer and birth defects or other reproductive harm. For more information, go to www.P65Warnings.ca.gov.

For more information go to <http://www.supermicro.com/support>

