

## Information for Lot 9 of ErP (Ecodesign)

This addendum addresses the European Union (EU) Ecodesign requirements for servers and storage products. All data and ratings within this addendum only references Supermicro product(s) that are in the manual. The information below conforms to the requirements laid down in Annex II of the Commission Regulation 2019/424.

- 3(1)(a): See Section 1.1 of the system manual for the product type.
- 3(1)(b): See the title page and preface of the system manual for the trademark and manufacturer's address.
- 3(1)(c): See the title page of the system manual for product model number(s).
- 3(1)(d): See the serial number on the physical system to determine the year of manufacture.
- 3(1)(e-j): **PSU Efficiency and Power Factor Value (Table) (From 80 Plus report)**

PSU Model #: PWS-802A-1R Watts: 800W	PSU Efficiency				Power Factor
	10 %	20 %	50 %	100 %	50 %
Single Output (AC-DC)	90.57 %	94.41 %	96.10 %	94.71 %	99 %

### System (EUT) Efficiency in **Idle State** Power (Table)

Representative Configurations	Measured Idle State Power (W)	Calculated Idle Power Allowance (W)
High-End Performance Configuration	273.60	337.25
Typical Configuration	N/A	N/A
Low-End Performance Configuration	130	255.20

### System (EUT) Efficiency in **Active State** Power (Table)

Representative Configurations	Active State Efficiency Score ( $Eff_{server}$ )	Minimum Active State Efficiency for Multi-Node Server
High-End Performance Configuration	19.0	8
Typical Configuration	N/A	
Low-End Performance Configuration	18.7	

3(1)(k): The operating condition class is **A2**.

Operating condition class	Dry bulb temp °C		Humidity range (non-condensing)		Max dew point (°C)	Maximum rate of change (°C/hr)
	Allowable range	Recommended range	Allowable range Dew Point (DP) Relative Humidity (RH)	Recommended range		
A1	15- 32	18-27	- 12 °C DP and 8 % RH to 17 °C DP and 80 % RH	- 9 °C DP to 15 °C DP and 60 % RH	17	5/20
A2	10-35	18-27	- 12 °C DP and 8 % RH to 21 °C DP and 80 % RH	Same as A1	21	5/20
A3	5-40	18-27	- 12 °C DP and 8 % RH to 24 °C DP and 85 % RH	Same as A1	24	5/20
A4	5-45	18-27	- 12 °C DP and 8 % RH to 24 °C DP and 90 % RH	Same as A1	24	5/20

3(1)(l): The idle state power at the higher boundary temperature of the operating conditions class is 273.60 W.

3(1)(m): The active state efficiency and performance is 19.0.

3(1)(n): There are two methods by which a user can securely delete data from this system. The user performing secure data deletion should be an IT professional.

The first is with a Unified Extensible Firmware Interface (UEFI) shell utility. This utility works on X10/X11/H11/H12/M11 motherboard series with onboard SATA/NVMe devices. Any user may access and download this utility through following link:

[https://www.supermicro.com/about/policies/disclaimer.cfm?url=/wftp/utility/Lot9\\_Secure\\_Data\\_Deletion\\_Utility/](https://www.supermicro.com/about/policies/disclaimer.cfm?url=/wftp/utility/Lot9_Secure_Data_Deletion_Utility/)

Download the shell utility package and extract it to a USB flash drive, then plug the drive into the server for which secure data deletion is necessary. Turn the system on, navigate to the BIOS setup menu, then place the server system into the UEFI shell environment. Follow the instructions in the README file to invoke the utility and complete the deletion.

The second method is through the secure data deletion tool provided by the original manufacturer of the hard drive. This should be used in a scenario where the shell utility is not applicable. Each manufacturer should have the tool available on their website. If needed, please look on the hard drive label for the name of the manufacturer and model information.

3(1)(o): List of recommended combinations of blade servers with chassis: N/A.

3(1)(p): List of all current SKUs within this product family: CSE-826BE1C-R802JBOD, CSE-826BE2C-R802JBOD.

3(3)(a): There is no use of cobalt in batteries in this product.

The indicative weight range of neodymium in the HDD is 0.0 if manufactured by Western Digital, and is between 5-25 grams if manufactured by Seagate.

3(3)(b): Please see the disassembly instructions on the next page.

## Illustrated System Disassembly Instructions

*Please note: All the illustrations in the below disassembly instructions are for demonstration only. Components shown here may not match exactly with the components in your system.*

**CAUTION: Always power off the system and unplug the power cord(s) first before disassembling the system!**

### 1. Chassis Cover

*Type and number of fastenings:* Two Phillips screws and two release tabs.

*Tools required:* Screwdriver with PH2 bit (Phillips-head).

*Procedure:* With a Phillips-head screwdriver, remove one screw on each side. Press and hold down the two release tabs on the cover and pull the cover out from the system.

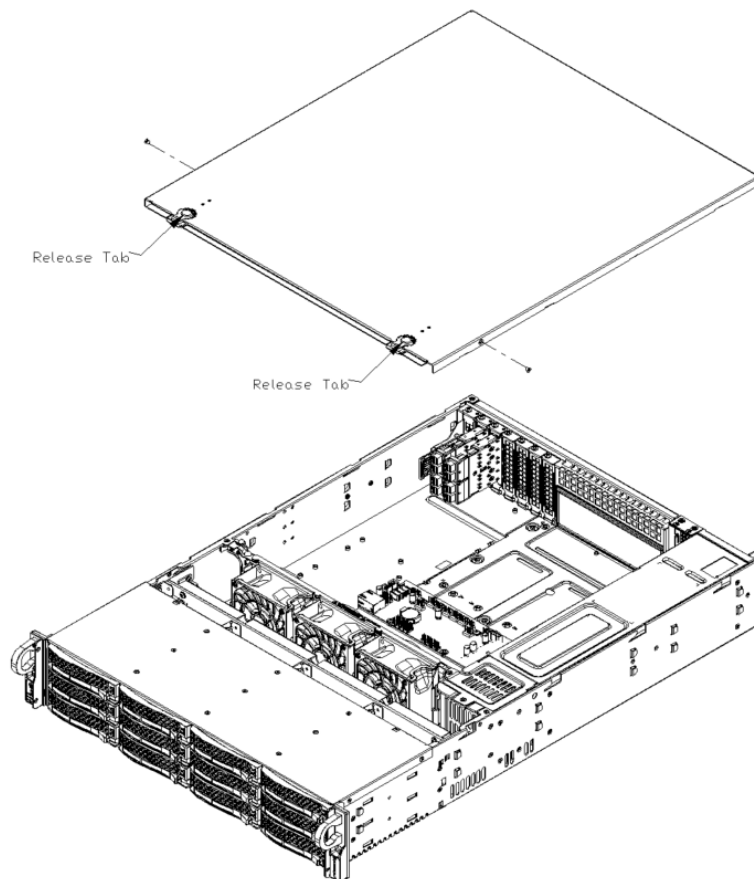

---

## 2. Hard Drives

*Type and number of fastenings:* One release tab.

*Tools required:* None.

*Procedure:* Press the release tab on the drive tray and use the handle to pull the tray out of the chassis.

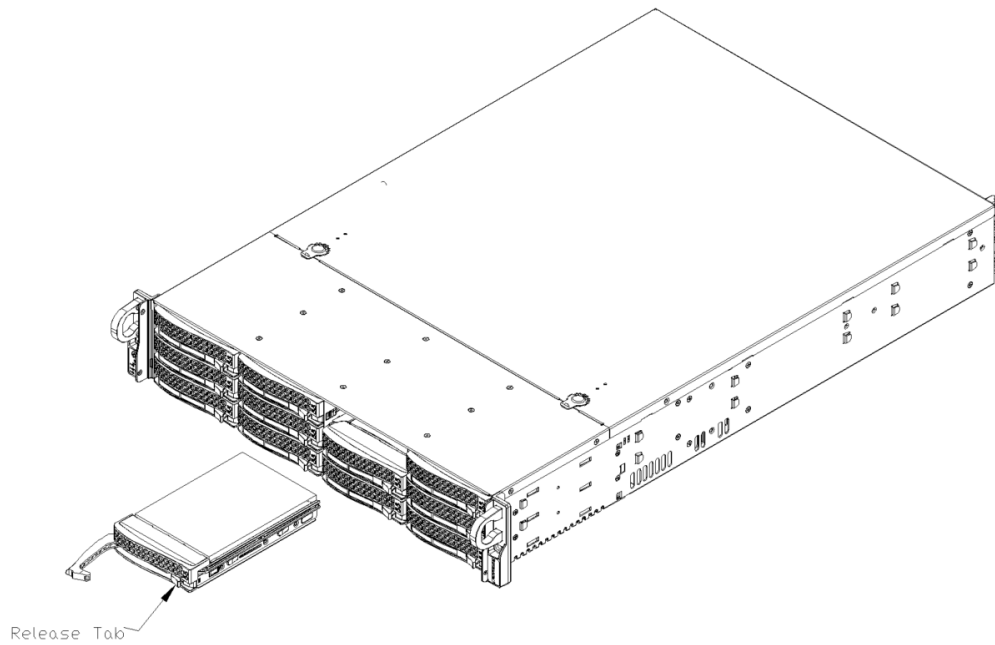

---

## 3. Fans

*Type and number of fastenings:* One release tab.

*Tools required:* None.

*Procedure:* Press the fan release tab and pull it completely out of the chassis.

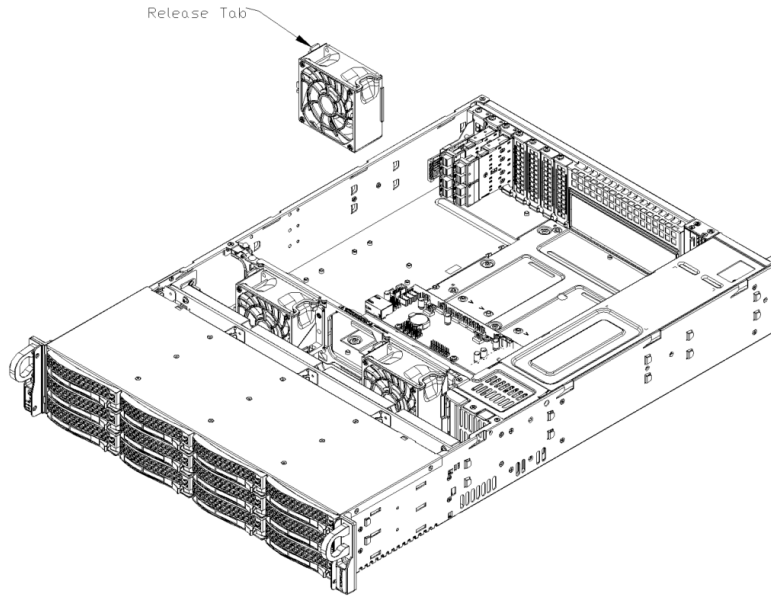

---

#### 4. Power Supply Module

*Type and number of fastenings:* One release tab per module.

*Tools required:* None.

*Procedure:* As illustrated, push the release tab on the back of the power supply to release the power supply module from the chassis.

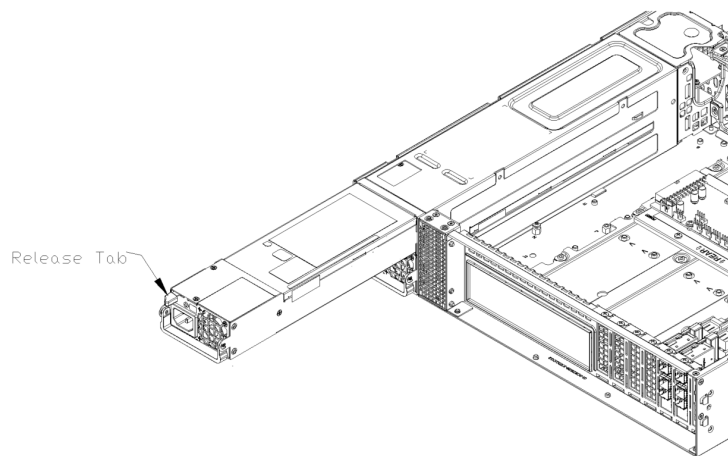

---

## 5. Control Board

*Type and number of fastenings:* Four Phillips screws in total.

*Tools required:* Screwdriver with PH2 bit (Phillips-head).

*Procedure:* With a Phillips-head screwdriver, remove four screws from the control board assembly, then lift the control board from its base.

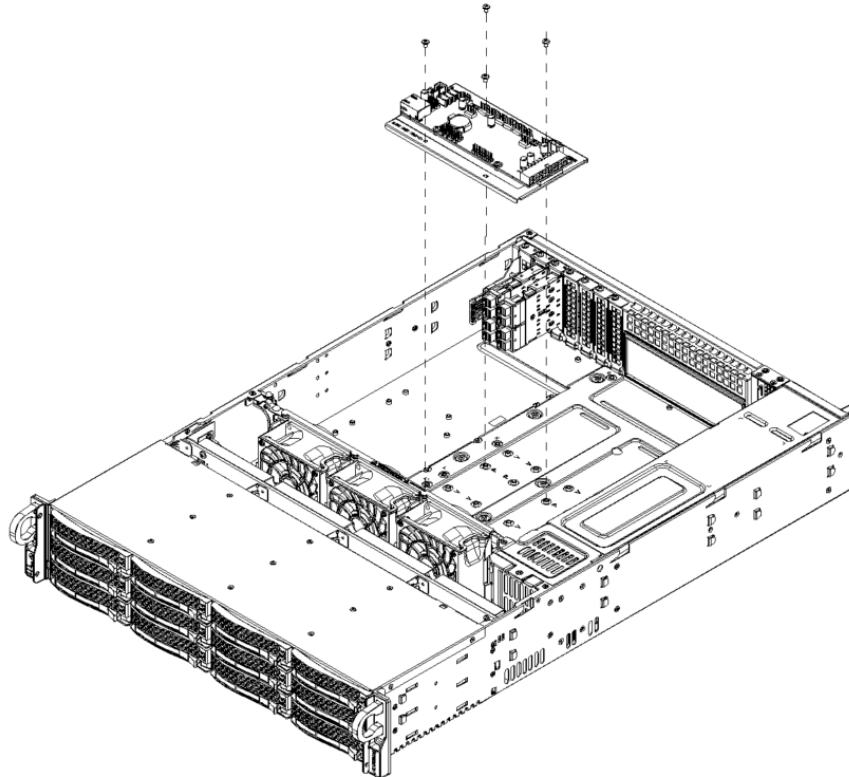

---

## 6. Batteries

*Type and number of fastenings:* One latch.

*Tools required:* None.

*Procedure:* Push the small latch that secures the edge of the battery outward. When the battery is released, lift it out of the holder.

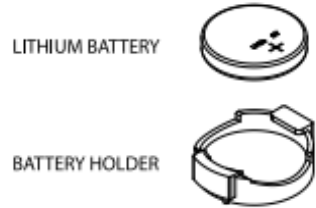

---

## 7. Add-On Card

Type and number of fastenings: One Phillips screw.

Tools required: Screwdriver with PH2 bit (Phillips-head).

Procedure: With a Phillips-head screwdriver, remove one screw that is securing the add-on card to the expansion bracket of the chassis. Gently ease the add-on card up and out of the chassis.

