

## Information for Lot 9 of ErP (Ecodesign)

This addendum addresses European Union (EU) Ecodesign requirements for servers and storage products. All data and ratings within this addendum are in reference only to the Supermicro product(s) in the manual. The below information conforms to requirements laid down in Annex II of the Commission Regulation 2019/424.

- 3(1)(a): See Section 1.1 of the system manual for the product type.
- 3(1)(b): See the title page and preface of the system manual for the trademark and manufacturer's address.
- 3(1)(c): See the title page of the system manual for product model number(s).
- 3(1)(d): See the serial number on the physical system to determine the year of manufacture.
- 3(1)(e-j): **PSU Efficiency and Power Factor Value (Table) (From 80 Plus report)**

PSU Model #: PWS-1K63A-1R Watts: 1600W	PSU Efficiency				Power Factor
% of Rated Load	10 %	20 %	50 %	100 %	50 %
Single Output (AC-DC)	91.17 %	94.46 %	96.15 %	94.89 %	99 %

### System (EUT) Efficiency in **Idle State** Power (Table)

Representative Configurations	Measured Idle State Power (W)	Calculated Idle Power Allowance (W)
High-End Performance Configuration	373.60	537.25
Typical Configuration	N/A	N/A
Low-End Performance Configuration	258.40	355.20

### System (EUT) Efficiency in **Active State** Power (Table)

Representative Configurations	Active State Efficiency Score ( $Eff_{server}$ )	Minimum Active State Efficiency for Multi-Node Server
High-End Performance Configuration	19.0	8
Typical Configuration	N/A	
Low-End Performance Configuration	18.7	

3(1)(k): The operating condition class is **A2**.

Operating condition class	Dry bulb temp °C		Humidity range (non-condensing)		Max dew point (°C)	Maximum rate of change (°C/hr)
	Allowable range	Recommended range	Allowable range Dew Point (DP) Relative Humidity (RH)	Recommended range		
A1	15- 32	18-27	- 12 °C DP and 8 % RH to 17 °C DP and 80 % RH	- 9 °C DP to 15 °C DP and 60 % RH	17	5/20
A2	10-35	18-27	- 12 °C DP and 8 % RH to 21 °C DP and 80 % RH	Same as A1	21	5/20
A3	5-40	18-27	- 12 °C DP and 8 % RH to 24 °C DP and 85 % RH	Same as A1	24	5/20
A4	5-45	18-27	- 12 °C DP and 8 % RH to 24 °C DP and 90 % RH	Same as A1	24	5/20

3(1)(l): The idle state power at the higher boundary temperature of the operating conditions class is 373.60 W.

3(1)(m): The active state efficiency and performance is 19.0.

3(1)(n): There are two methods by which a user can securely delete data from this system. The user performing secure data deletion should be an IT professional.

The first is with a Unified Extensible Firmware Interface (UEFI) shell utility. This utility works on X10/X11/H11/H12/M11 motherboard series with onboard SATA/NVMe devices. Any user may access and download this utility through following link:

[https://www.supermicro.com/about/policies/disclaimer.cfm?url=/wftp/utility/Lot9\\_Secure\\_Data\\_Deletion\\_Utility/](https://www.supermicro.com/about/policies/disclaimer.cfm?url=/wftp/utility/Lot9_Secure_Data_Deletion_Utility/)

Download the shell utility package and extract it to a USB flash drive, then plug the drive into the server for which secure data deletion is necessary. Then turn the system on. Navigate to the BIOS setup menu, then place the server system into the UEFI shell environment. Follow the instructions in the README file to invoke the utility and complete the deletion.

The second method is through the secure data deletion tool provided by the original manufacturer of the hard drive. This should be used in a scenario where the shell utility is not applicable. Each manufacturer should have the tool available on their website. If needed, please look on the hard drive label for the name of the manufacturer and model information.

3(1)(o): List of recommended combinations of blade servers with chassis: N/A.

3(1)(p): List of all current SKUs within this product family: CSE-947SE1C-R1K63JBOD, CSE-947SE2C-R1K63JBOD.

3(3)(a): There is no use of cobalt in batteries in this product.

The indicative weight range of neodymium in the HDD is 0.0 if manufactured by Western Digital, and is between 5-25 grams if manufactured by Seagate.

3(3)(b): Please see the disassembly instructions on the next page.

# Illustrated System Disassembly Instructions

*Please note: All the illustrations in the below disassembly instructions are for demonstration only. Components shown here may not match exactly with the components in your system.*

**CAUTION: Always power off the system and unplug the power cord(s) first before disassembling the system!**

## 1. I/O Module

Type and number of fastenings: Two (2) latches per module.

Tools required: None.

Procedure: Press and hold down the release tab on the front of the node, then pull down the lever and pull the node out from the system.

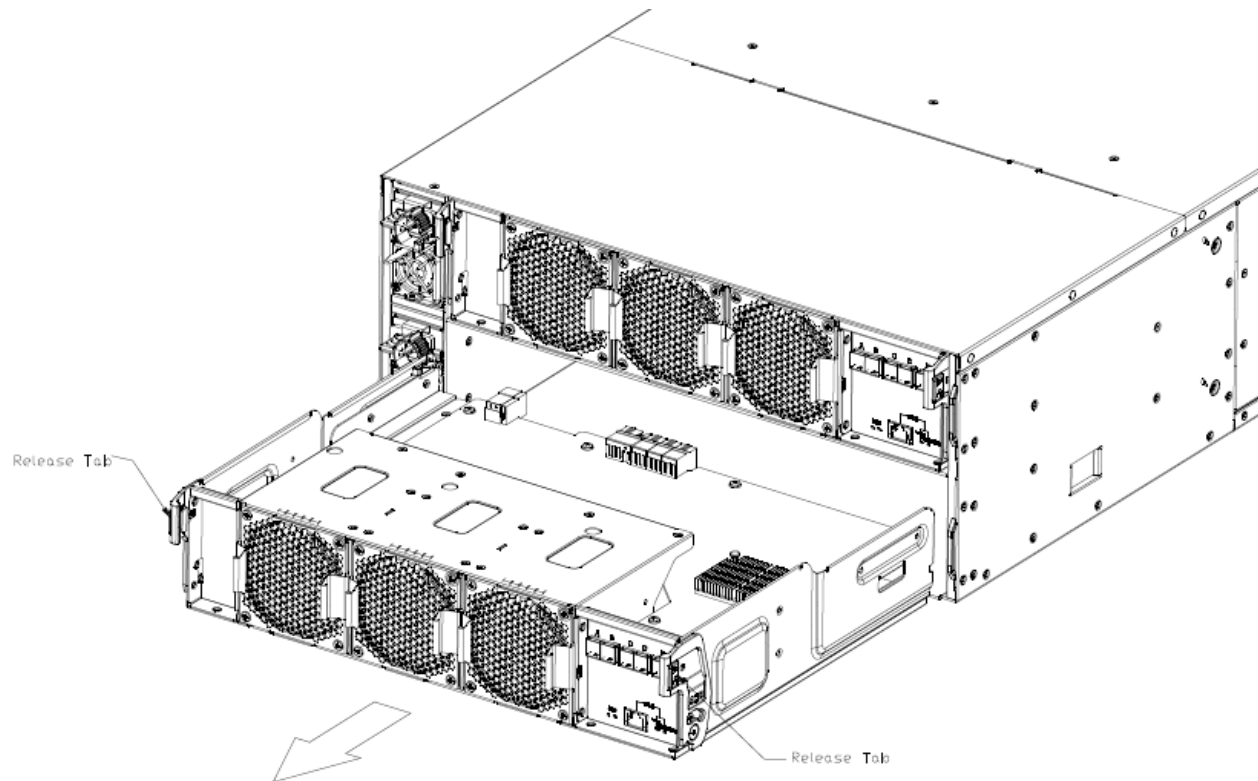

---

## 2. Motherboard

*Type and number of fastenings:* 24 Phillips screws in total.

*Tools required:* Screwdriver with PH2 bit.

*Procedure:* With a screwdriver, remove eight screws on the top board, then four screws on the side, and four screws on the bracket. Finally, remove eight screws on the bottom board. Lift the motherboard from its base.

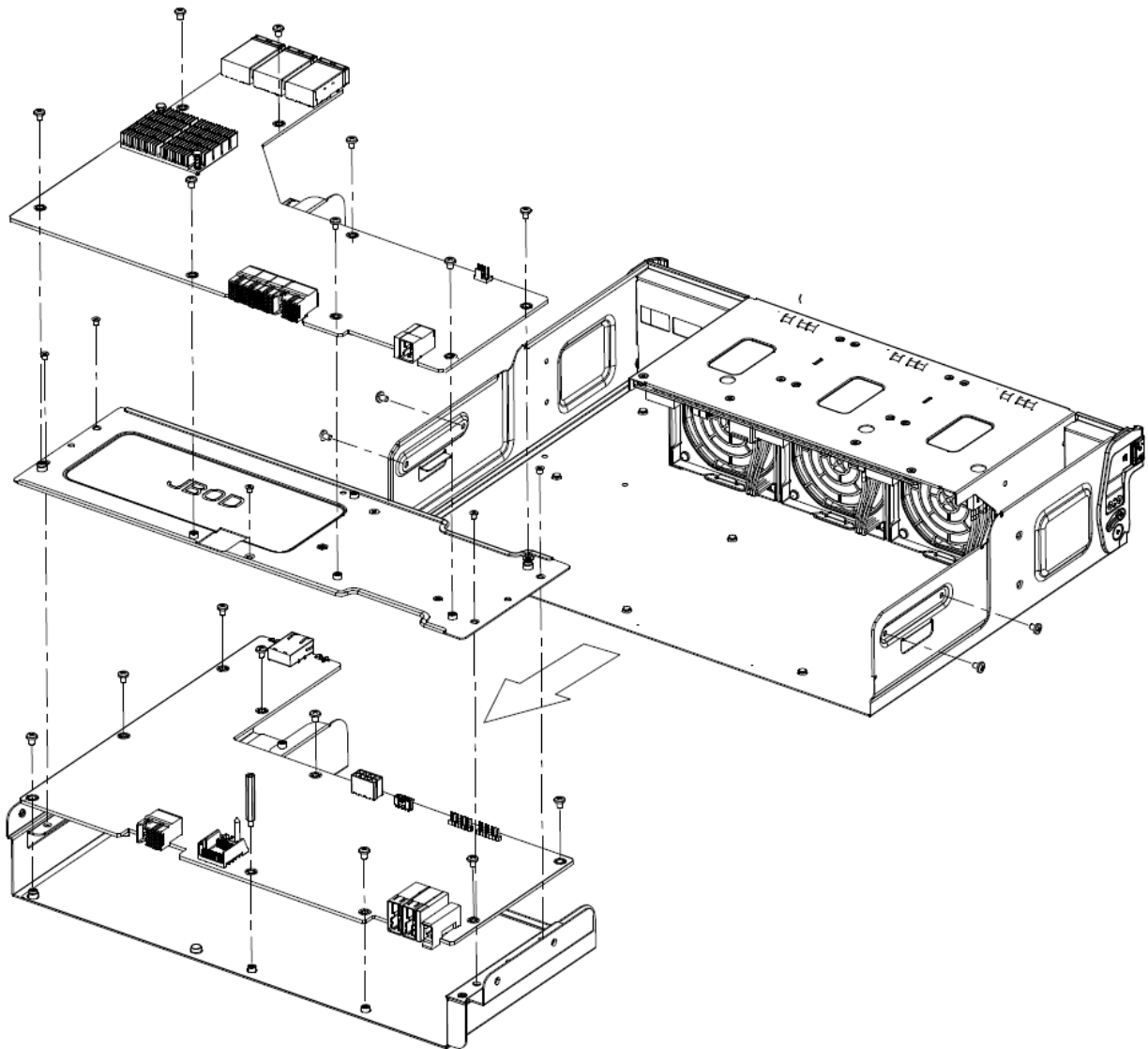

---

### 3. Batteries

Type and number of fastenings: One (1) latch.

Tools required: None.

Procedure: Push aside the small clamp that covers the edge of the battery. When the battery is released, lift it out of the holder.

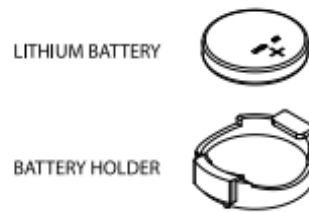

---

### 4. Hard Drives

Type and number of fastenings: Two (2) latches.

Tools required: None.

Procedure: Slide the release button on the drive carrier to open the carrier handle. Pull the drive carrier up and out using the handle. Slide the carrier breakout lever and pull the side of the carrier out to release the hard drive.

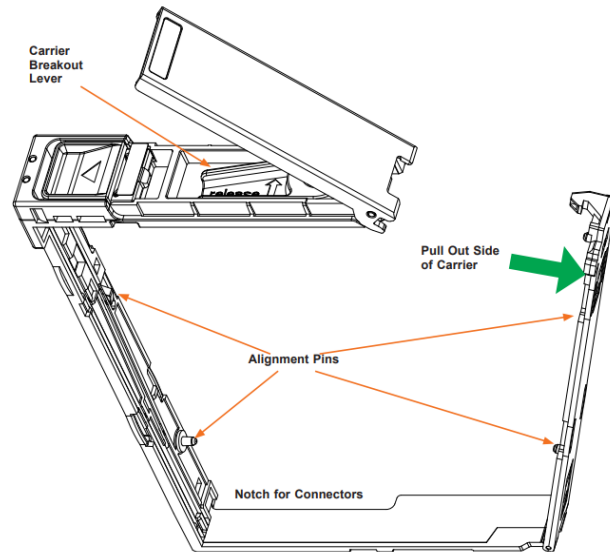
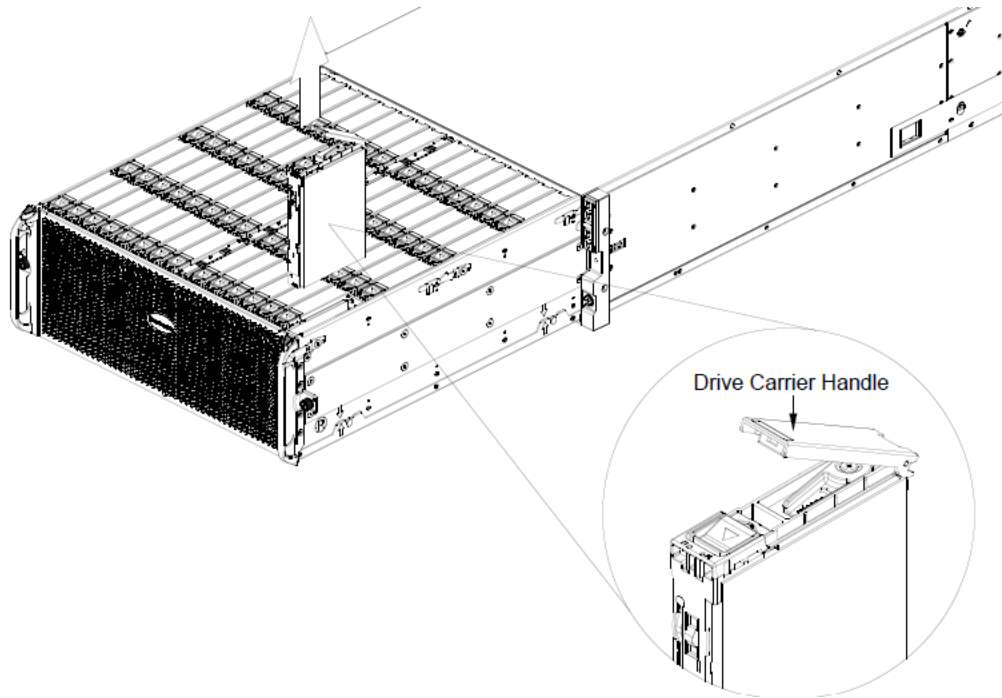

## 5. Power Supply Module

*Type and number of fastenings:* One (1) latch per module.

*Tools required:* None.

*Procedure:* Unplug the power cord from the power supply. Push the release tab on the back of the power supply module to the side and pull the module straight out.

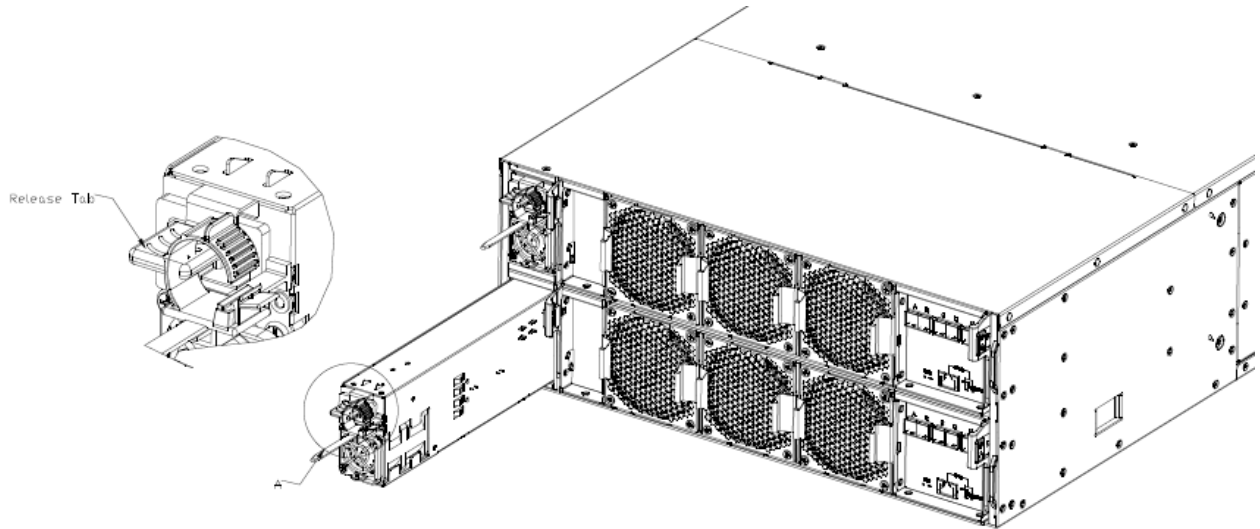

## 6. Chassis Cover

Type and number of fastenings: Five (5) Phillips screws.

Tools required: Screwdriver with PH2 bit.

Procedure: Remove the screws securing the cover to the chassis: three screws on top and one on each side. Slide the cover out from the chassis.

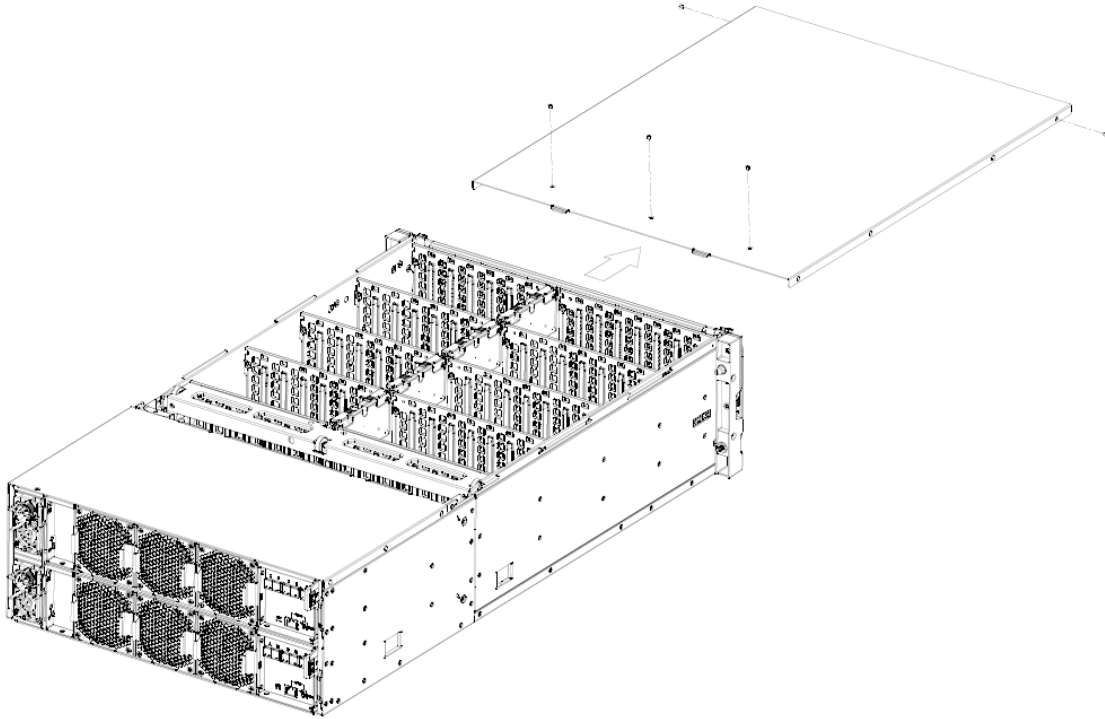

---

## 7. Fans

Type and number of fastenings: Two (2) release tabs.

Tools required: None.

Procedure: Push both release tabs on the fan inward. Remove the fan from the chassis. The wiring will disconnect automatically.

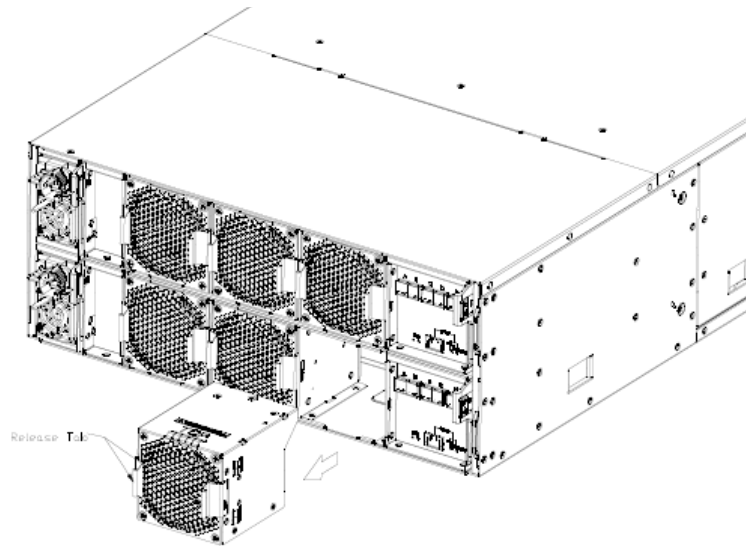

## 8. Expender Module

Type and number of fastenings: Two (2) release tabs.

Tools required: None.

Procedure: Unlock both release tabs on the extender cards. Remove the extender Cards from the chassis.

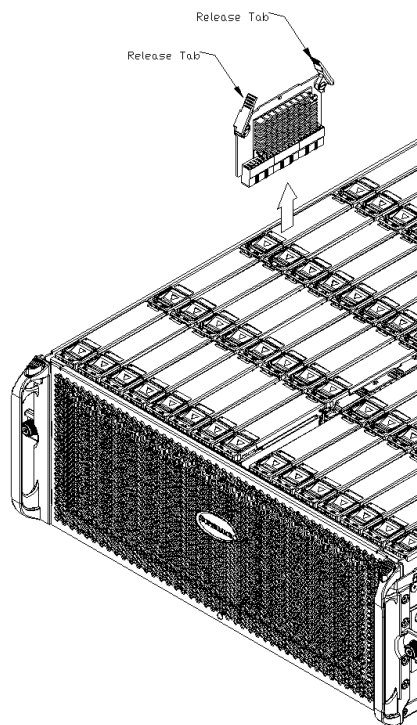

## 9. 60Bays tray

*Type and number of fastenings:* Six (6) release tabs.

*Tools required:* None.

*Procedure:* Press and hold down the release tab on each step, pull the 60Bays tray out from the system.

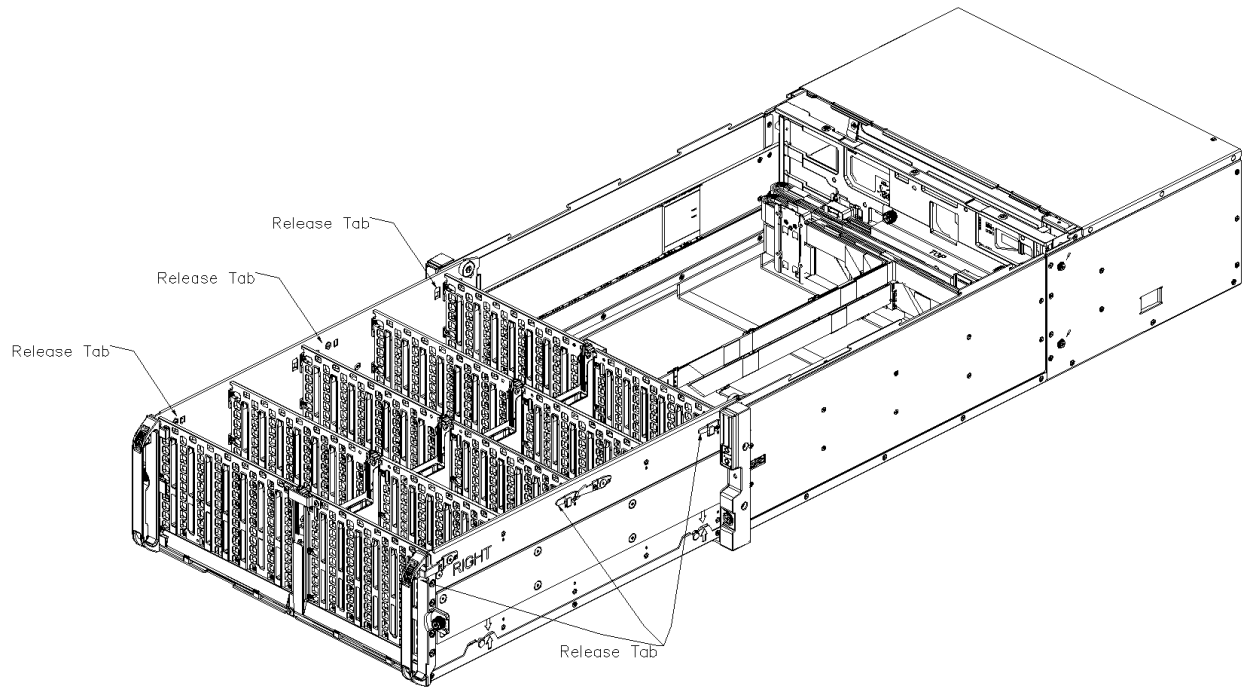

## 10.HDD boards

*Type and number of fastenings:* 46 Phillips screws in total

*Tools required:* Screwdriver with PH2 bit.

*Procedure:* With a screwdriver, remove ten screws for the HDD partitions. Finally, remove thirty-six screws on the HDD boards. Lift the HDD boards from its base.

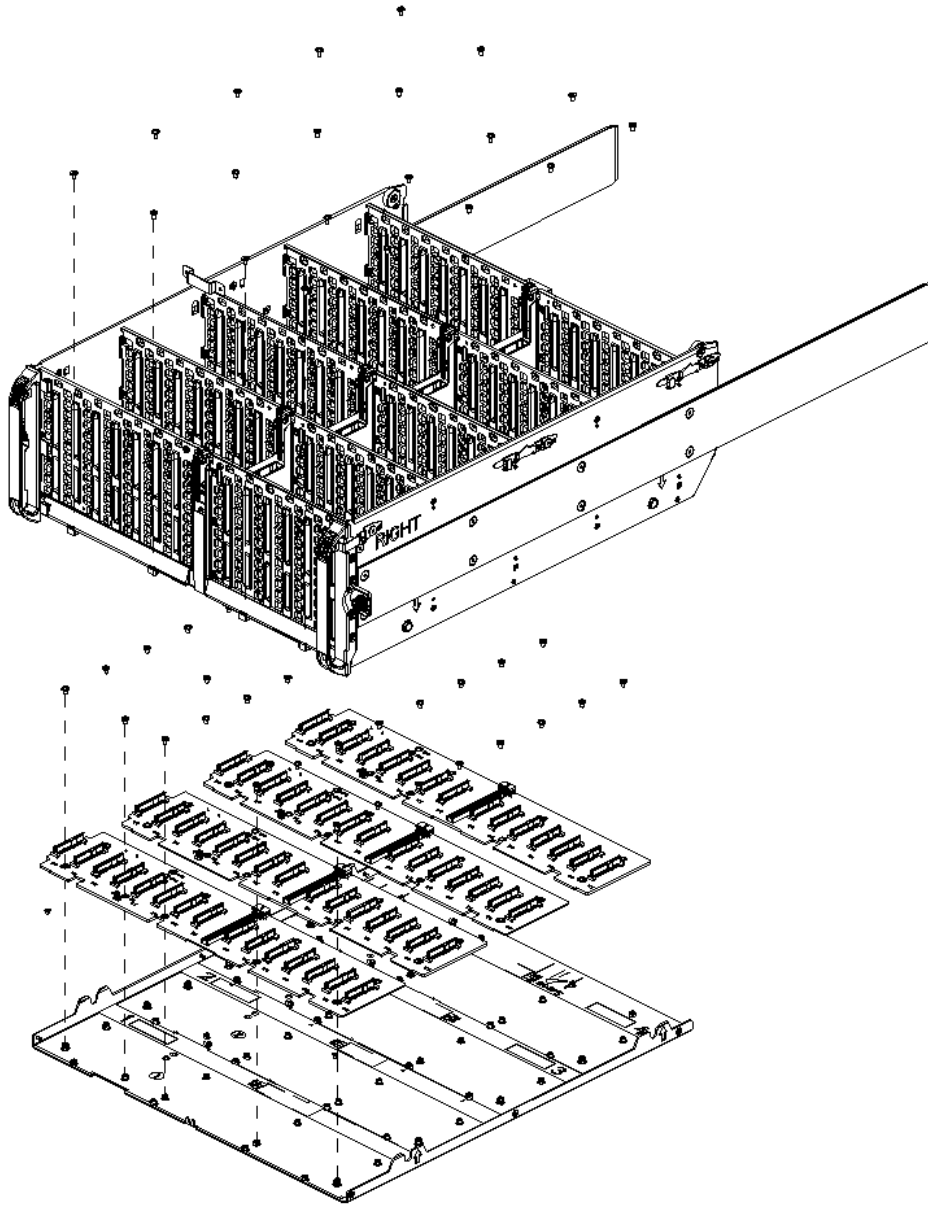

## 11.Adapter boards

*Type and number of fastenings:* Eight (8) Phillips screws.

*Tools required:* Screwdriver with PH2 bit.

*Procedure:* With a screwdriver, remove four screws for secure part of L/R HDD module. Finally, remove four screws on the adapter boards. Lift the Adapter boards from its HDD module.

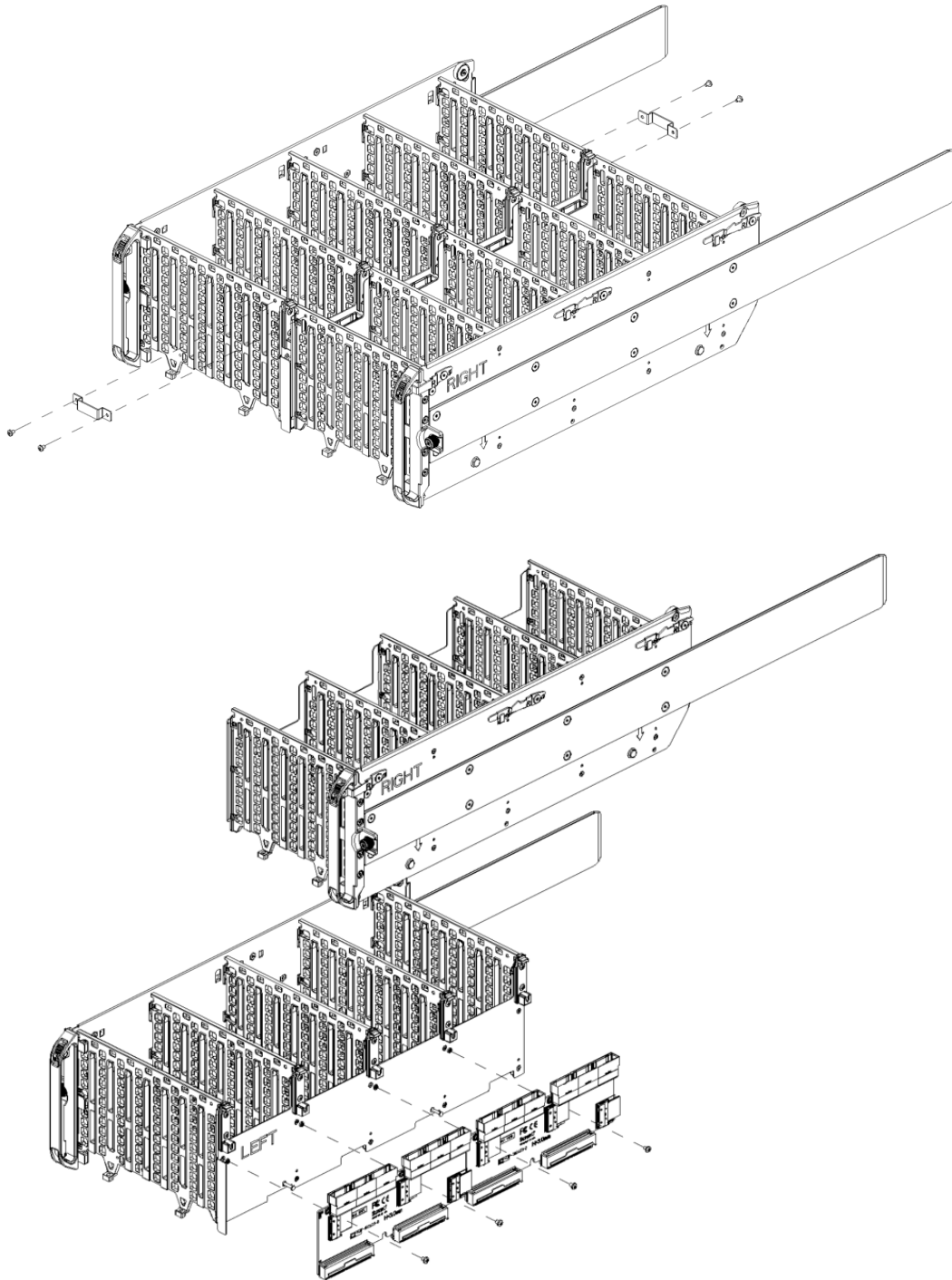

## 12. Midplane

*Type and number of fastenings:* Two (2) release Thumbscrews and Twelve (12) Phillips screws.

*Tools required:* Screwdriver with PH2 bit.

*Procedure:* With a screwdriver, release two thumbscrews of secure cable parts then remove cables and parts. Release four screws on the chassis then pull up mid-plane module. Finally, remove twelve screws on the mid-plane. Remove the Mid-plane from its middle bracket.

