



MBI-6118G-T81X MicroBlade® Module



User's Manual

Revision 1.0b

The information in this User's Manual has been carefully reviewed and is believed to be accurate. The vendor assumes no responsibility for any inaccuracies that may be contained in this document, and makes no commitment to update or to keep current the information in this manual, or to notify any person or organization of the updates. **Please Note: For the most up-to-date version of this manual, please see our website at www.supermicro.com.**

Super Micro Computer, Inc. ("Supermicro") reserves the right to make changes to the product described in this manual at any time and without notice. This product, including software and documentation, is the property of Supermicro and/or its licensors, and is supplied only under a license. Any use or reproduction of this product is not allowed, except as expressly permitted by the terms of said license.

IN NO EVENT WILL Super Micro Computer, Inc. BE LIABLE FOR DIRECT, INDIRECT, SPECIAL, INCIDENTAL, SPECULATIVE OR CONSEQUENTIAL DAMAGES ARISING FROM THE USE OR INABILITY TO USE THIS PRODUCT OR DOCUMENTATION, EVEN IF ADVISED OF THE POSSIBILITY OF SUCH DAMAGES. IN PARTICULAR, SUPER MICRO COMPUTER, INC. SHALL NOT HAVE LIABILITY FOR ANY HARDWARE, SOFTWARE, OR DATA STORED OR USED WITH THE PRODUCT, INCLUDING THE COSTS OF REPAIRING, REPLACING, INTEGRATING, INSTALLING OR RECOVERING SUCH HARDWARE, SOFTWARE, OR DATA.

Any disputes arising between manufacturer and customer shall be governed by the laws of Santa Clara County in the State of California, USA. The State of California, County of Santa Clara shall be the exclusive venue for the resolution of any such disputes. Supermicro's total liability for all claims will not exceed the price paid for the hardware product.

FCC Statement: This equipment has been tested and found to comply with the limits for a Class A digital device pursuant to Part 15 of the FCC Rules. These limits are designed to provide reasonable protection against harmful interference when the equipment is operated in industrial environment. This equipment generates, uses, and can radiate radio frequency energy and, if not installed and used in accordance with the manufacturer's instruction manual, may cause harmful interference with radio communications. Operation of this equipment in a residential area is likely to cause harmful interference, in which case you will be required to correct the interference at your own expense.

California Best Management Practices Regulations for Perchlorate Materials: This Perchlorate warning applies only to products containing CR (Manganese Dioxide) Lithium coin cells. "Perchlorate Material-special handling may apply. See www.dtsc.ca.gov/hazardouswaste/perchlorate".



WARNING: This product can expose you to chemicals including lead, known to the State of California to cause cancer and birth defects or other reproductive harm. For more information, go to www.P65Warnings.ca.gov.

Manual Revision 1.0b

Release Date: April 21, 2023

Unless you request and receive written permission from Super Micro Computer, Inc., you may not copy any part of this document. Information in this document is subject to change without notice. Other products and companies referred to herein are trademarks or registered trademarks of their respective companies or mark holders.

Copyright © 2023 by Super Micro Computer, Inc.
All rights reserved.

Printed in the United States of America

Preface

About this Manual

This manual is written for professional system integrators, Information Technology professionals, service personnel and technicians. It provides information for the installation and use of the Supermicro MBI-6118G-T81X MicroBlade module. Installation and maintenance should be performed by experienced professionals only.

Manual Organization

Chapter 1: Introduction

The first chapter provides a checklist of the main components included with MBI-6118G-T81X MicroBlade module and describes their main features.

Chapter 2: System Safety

You should familiarize yourself with this chapter for a general overview of safety precautions that should be followed when installing and servicing MBI-6118G-T81X MicroBlade module.

Chapter 3: Setup and Installation

Refer to this chapter for details on installing the MBI-6118G-T81X MicroBlade module into the MicroBlade chassis. Other sections cover the installation and placement of memory modules and the installation of hard disk drives into the blade module.

Chapter 4: Blade Module Features

This chapter covers features and component information about MBI-6118G-T81X MicroBlade module. Included here are descriptions and information for mainboard components, connectors, LEDs and other features of the blade module.

Chapter 5: BIOS

BIOS setup is covered in this chapter for MBI-6118G-T81X MicroBlade module.

Appendix A: BIOS POST Codes

BIOS POST Codes for MBI-6118G-T81X MicroBlade module are explained in this appendix.

Secure Data Deletion

A secure data deletion tool designed to fully erase all data from storage devices can be found on our website: https://www.supermicro.com/about/policies/disclaimer.cfm?url=/wftp/utility/Log9_Secure_Data_Deletion_Utility/

Table of Contents

Chapter 1 Introduction	1-1
1-1 Overview.....	1-1
1-2 Blade Module Features.....	1-2
Processors.....	1-2
Memory.....	1-2
Storage.....	1-3
RAID.....	1-3
Density.....	1-3
BMC Password.....	1-3
1-3 Contacting Supermicro.....	1-4
Chapter 2 Standardized Warning Statements	2-1
2-1 About Standardized Warning Statements.....	2-1
Warning Definition.....	2-1
Installation Instructions.....	2-3
Circuit Breaker.....	2-4
Power Disconnection Warning.....	2-5
Equipment Installation.....	2-6
Restricted Area.....	2-7
Battery Handling.....	2-9
Redundant Power Supplies.....	2-10
Backplane Voltage.....	2-11
Comply with Local and National Electrical Codes.....	2-12
Product Disposal.....	2-13
Hot Swap Fan Warning.....	2-14
Power Cable and AC Adapter.....	2-15
Chapter 3 Setup and Installation	3-1
3-1 Overview.....	3-1
3-2 Installing MicroBlade Modules.....	3-1
Powering Up a MicroBlade Module Unit.....	3-1
Powering Down a MicroBlade Module Unit.....	3-1
Removing a MicroBlade Module Unit from the Enclosure.....	3-2
Installing a Blade Unit into the Enclosure.....	3-2
3-3 Onboard Battery Installation.....	3-3
3-4 Memory Installation.....	3-4

Populating Memory Slots	3-4
DIMM Installation	3-4
3-5 Hard Disk Drive Installation	3-5
3-6 Installing the Operating System	3-5
Installing with a SATA-DOM Module	3-5
Installing via PXE Boot.....	3-6
Installing via Virtual Media (Drive Redirection)	3-6
Chapter 4 MicroBlade Module Features	4-1
4-1 Control Panel	4-2
Power Button	4-3
LED Indicators	4-3
4-2 Serverboard	4-4
Jumpers	4-5
CMOS Clear.....	4-6
4-3 Blade Unit Components	4-7
Memory Support	4-7
Hard Disk Drives	4-8
Chapter 5 BIOS	5-1
5-1 Introduction.....	5-1
System BIOS	5-1
How To Change the Configuration Data	5-1
Starting the Setup Utility	5-1
5-2 BIOS Updates.....	5-2
Flashing BIOS.....	5-2
5-3 Running Setup	5-3
5-4 Main BIOS Setup.....	5-4
5-5 Advanced Setup	5-5
5-6 Event Logs Setup.....	5-17
5-7 IPMI Setup.....	5-18
5-8 Security	5-20
5-9 Boot	5-22
5-10 Save & Exit.....	5-23
Appendix A AMI UEFI BIOS POST Codes	A-1
A-1 Checkpoint Ranges	A-1
A-2 Standard Checkpoints.....	A-2

A-3 OEM-Reserved Checkpoint RangesA-9

Chapter 1

Introduction

1-1 Overview

This user's manual covers the MBI-6118G-T81X MicroBlade module. This MicroBlade module is a compact self-contained server that connects into a pre-cabled enclosure that provides power, cooling, management and networking functions. One enclosure for the MBI-6118G-T81X MicroBlade module can hold twenty-eight blade units. The MBI-6118G-T81X uses the Intel Xeon D-1581 processor.

In this manual, "blade system" refers to the entire system (including the enclosure and blades units), "blade", "MicroBlade" or "blade unit" refers to a single MicroBlade module and "blade enclosure" is the chassis that the MicroBlades, power supplies and MicroBlade modules are housed within.

Please refer to our web site for information on operating systems that have been certified for use with the MicroBlade (<http://www.supermicro.com/products/info/microblade.cfm>).

Note: For your system to work properly, please follow the links below to download all necessary drivers/utilities and the user's manual for your server.

- Supermicro product manuals: <http://www.supermicro.com/support/manuals/>
- Product drivers and utilities: <ftp://ftp.supermicro.com>
- If you have any questions, please contact our support team at: **support@supermicro.com**

Note: A complete list of safety warnings is provided on the Supermicro web site at http://www.supermicro.com/about/policies/safety_information.cfm.

1-2 Blade Module Features

Table 1-1 lists the main features of the MBI-6118G-T81X MicroBlade module. See the proceeding section for components typically included in a blade system and other optional components. Specific details for the MBI-6118G-T81X MicroBlade module are found in Chapter 4: "MicroBlade Module Features" on page 4-1.

Table 1-1. MBI-6118G-T81X MicroBlade Module Specification Features

Serverboard	B1SD1-16C-TF (proprietary form factor)
Enclosures	MBE-628E-xxx and MBE-314E-xxx
Chassis Specifications	Chassis Dimensions (HxWxD): 1.2" x 4.94" x 23.2" (30.48-mm x 125.476-mm x 589.28-mm), Gross Weight: 5.67 lbs (2.57 kg)
Processors	One Intel Xeon D-1581 embedded in a FCBGA 1667 socket on the serverboard
BIOS	128 Mb SPI Flash EEPROM with AMI® BIOS
Memory Capacity	Supports up to 128 GB of DDR4 2133/2400 MHz speed and 32 GB size, 1.2 V voltage ECC VLP RDIMM memory in four (4) 288-pin DIMM sockets
Hard Drive Bays	Supports up to four 2.5" SATA3 (6 Gbps) HDD/SSD disk drives (two HDD/SSD and two SSD)

Processors

The MBI-6118G-T81X MicroBlade module supports a single FCBGA 1667 Intel Xeon D-1581 series processors in a FCBGA 1667 socket embedded in the motherboard.

Refer to the Supermicro web site for a complete listing of supported processors (<http://www.supermicro.com/products/microblade>). Please note that you will need to check the detailed specifications of a particular blade module for a list of the CPUs it supports.

Details on installation of the processor into the MBI-6118G-T81X MicroBlade module are found in Chapter 3: "Setup and Installation" on page 3-1.

Memory

The MBI-6118G-T81X MicroBlade module has four (4) 288-pin DIMM sockets that can support up to 128 GB of DDR4 2133/2400 MHz speed, 32 GB size, 1.2 V voltage ECC VLP RDIMM memory. Memory is interleaved, which requires modules to be of the same size and speed.

Please refer to the Supermicro web site for a list of supported memory <http://www.supermicro.com/products/microblade> The detailed specifications for a blade module will contain a link to a list of recommended memory sizes and manufacturers.

Details on installation of memory modules into the MBI-6118G-T81X MicroBlade module are found in Chapter 3: "Setup and Installation" on page 3-1.

Storage

The MBI-6118G-T81X MicroBlade module has four 2.5" SATA3 HDD/SSD internally mounted for storage or for installation of the blade's operating system. See [Chapter 3: "Setup and Installation" on page 3-1](#) for storage installation details.

RAID

The MBI-6118G-T81X MicroBlade module supports up to four drives so RAID 0, 1 and 10 are supported.

Density

A maximum of twenty-eight blade modules may be installed into a single blade enclosure. Each blade enclosure is a 6U form factor, so a standard 42U rack may accommodate up to seven enclosures with 196 blade modules or the equivalent of 196 1U servers. With the inclusion of up to fourteen CMM modules and up to twenty-eight Gigabit Ethernet switches this would occupy up to 238U space in a conventional 1U server configuration.

BMC Password

For security, each blade unit is assigned a unique default BMC password for the ADMIN user. It can be found on a sticker on the blade service tab, and a sticker on the motherboard. The sticker also displays the BMC MAC address. For more information, refer to our website at https://www.supermicro.com/en/support/BMC_Unique_Password. The service tab and an example sticker are illustrated below.

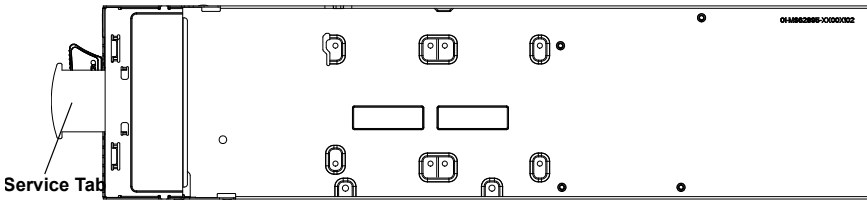

Password
Sticker



1-3 Contacting Supermicro

Headquarters

Address: Super Micro Computer, Inc.
980 Rock Ave.
San Jose, CA 95131 U.S.A.

Tel: +1 (408) 503-8000

Fax: +1 (408) 503-8008

Email: marketing@supermicro.com (General Information)
support@supermicro.com (Technical Support)

Web Site: www.supermicro.com

Europe

Address: Super Micro Computer B.V.
Het Sterrenbeeld 28, 5215 ML
's-Hertogenbosch, The Netherlands

Tel: +31 (0) 73-6400390

Fax: +31 (0) 73-6416525

Email: sales@supermicro.nl (General Information)
support@supermicro.nl (Technical Support)
rma@supermicro.nl (Customer Support)

Asia-Pacific

Address: Super Micro Computer, Inc.
3F, No. 150, Jian 1st Rd.
Zhonghe Dist., New Taipei City 23511
Taiwan (R.O.C)

Tel: +886-(2) 8226-3990

Fax: +886-(2) 8226-3992

Web Site: www.supermicro.com.tw

Technical Support:

Email: support@supermicro.com.tw

Tel: +886-(2)-8226-3990

Chapter 2

Standardized Warning Statements

2-1 About Standardized Warning Statements

The following statements are industry standard warnings, provided to warn the user of situations which have the potential for bodily injury. Should you have questions or experience difficulty, contact Supermicro's Technical Support department for assistance. Only certified technicians should attempt to install or configure components.

Read this appendix in its entirety before installing or configuring components in the Supermicro chassis

These warnings may also be found on our website at http://www.supermicro.com/about/policies/safety_information.cfm.

Warning Definition



Warning!

This warning symbol means danger. You are in a situation that could cause bodily injury. Before you work on any equipment, be aware of the hazards involved with electrical circuitry and be familiar with standard practices for preventing accidents.

警告の定義

この警告サインは危険を意味します。

人身事故につながる可能性がありますので、いずれの機器でも動作させる前に、電気回路に含まれる危険性に注意して、標準的な事故防止策に精通して下さい。

此警告符号代表危險。

您正處於可能受到嚴重傷害的工作環境中。在您使用設備開始工作之前，必須充分意識到觸電的危險，並熟練掌握防止事故發生的標準工作程序。請根據每項警告結尾的聲明號碼找到此設備的安全性警告說明的翻譯文本。

此警告符號代表危險。

您正處於可能身體可能會受損傷的工作環境中。在您使用任何設備之前，請注意觸電的危險，並且要熟悉預防事故發生的標準工作程序。請依照每一注意事項後的號碼找到相關的翻譯說明內容。

Warnung

WICHTIGE SICHERHEITSHINWEISE

Dieses Warnsymbol bedeutet Gefahr. Sie befinden sich in einer Situation, die zu Verletzungen führen kann. Machen Sie sich vor der Arbeit mit Geräten mit den Gefahren elektrischer Schaltungen und den üblichen Verfahren zur Vorbeugung vor Unfällen vertraut. Suchen Sie mit der am Ende jeder Warnung angegebenen Anweisungsnummer nach der jeweiligen Übersetzung in den übersetzten Sicherheitshinweisen, die zusammen mit diesem Gerät ausgeliefert wurden.

BEWAHREN SIE DIESE HINWEISE GUT AUF.

INSTRUCCIONES IMPORTANTES DE SEGURIDAD

Este símbolo de aviso indica peligro. Existe riesgo para su integridad física. Antes de manipular cualquier equipo, considere los riesgos de la corriente eléctrica y familiarícese con los procedimientos estándar de prevención de accidentes. Al final de cada advertencia encontrará el número que le ayudará a encontrar el texto traducido en el apartado de traducciones que acompaña a este dispositivo.

GUARDE ESTAS INSTRUCCIONES.

IMPORTANTES INFORMATIONS DE SÉCURITÉ

Ce symbole d'avertissement indique un danger. Vous vous trouvez dans une situation pouvant entraîner des blessures ou des dommages corporels. Avant de travailler sur un équipement, soyez conscient des dangers liés aux circuits électriques et familiarisez-vous avec les procédures couramment utilisées pour éviter les accidents. Pour prendre connaissance des traductions des avertissements figurant dans les consignes de sécurité traduites qui accompagnent cet appareil, référez-vous au numéro de l'instruction situé à la fin de chaque avertissement.

CONSERVEZ CES INFORMATIONS.

הצהרות הבאות הן אזהרות על פי תקני התעשייה, על מנת להזהיר את המשתמש מפני חבלה פיזית אפשרית. במידה ויש שאלות או היתקלות בבעיה כלשהי, יש ליצור קשר עם מחלקת תמיכה טכנית של סופרמיקרו. טכנאים מוסמכים בלבד רשאים להתקין או להגדיר את הרכיבים.

יש לקרוא את הנספח במלואו לפני התקנת או הגדרת הרכיבים במארזי סופרמיקרו.

تحذير! هذا الرمز يعني خطر انك في حالة يمكن أن تتسبب في اصابة جسدية .
قبل أن تعمل على أي معدات، كن على علم بالمخاطر الناجمة عن الدوائر
الكهربائية

وكن على دراية بالممارسات الوقائية لمنع وقوع أي حوادث
استخدم رقم البيان المنصوص في نهاية كل تحذير للعثور ترجمتها

안전을 위한 주의사항

경고!

이 경고 기호는 위험이 있음을 알려 줍니다. 작업자의 신체에 부상을 야기 할 수 있는 상태에 있게 됩니다. 모든 장비에 대한 작업을 수행하기 전에 전기회로와 관련된 위험 요소들을 확인하시고 사전에 사고를 방지할 수 있도록 표준 작업절차를 준수해 주시기 바랍니다.

해당 번역문을 찾기 위해 각 경고의 마지막 부분에 제공된 경고문 번호를 참조하십시오

BELANGRIJKE VEILIGHEIDSINSTRUCTIES

Dit waarschuwings symbool betekent gevaar. U verkeert in een situatie die lichamelijk letsel kan veroorzaken. Voordat u aan enige apparatuur gaat werken, dient u zich bewust te zijn van de bij een elektrische installatie betrokken risico's en dient u op de hoogte te zijn van de standaard procedures om ongelukken te voorkomen. Gebruik de nummers aan het eind van elke waarschuwing om deze te herleiden naar de desbetreffende locatie.

BEWAAR DEZE INSTRUCTIES

Installation Instructions



Warning!

Read the installation instructions before connecting the system to the power source.

設置手順書

システムを電源に接続する前に、設置手順書をお読み下さい。

警告

将此系统连接电源前，请先阅读安装说明。

警告

將系統與電源連接前，請先閱讀安裝說明。

Warnung

Vor dem Anschließen des Systems an die Stromquelle die Installationsanweisungen lesen.

¡Advertencia!

Lea las instrucciones de instalación antes de conectar el sistema a la red de alimentación.

Attention

Avant de brancher le système sur la source d'alimentation, consulter les directives d'installation.

יש לקרוא את הוראות התקנה לפני חיבור המערכת למקור מתח.

اقر إرشادات التركيب قبل توصيل النظام إلى مصدر للطاقة
시스템을 전원에 연결하기 전에 설치 안내를 읽어주십시오.

Waarschuwing

Raadpleeg de installatie-instructies voordat u het systeem op de voedingsbron aansluit.

Circuit Breaker



Warning!

This product relies on the building's installation for short-circuit (overcurrent) protection. Ensure that the protective device is rated not greater than: 250 V, 20 A.

サーキット・ブレーカー

この製品は、短絡（過電流）保護装置がある建物での設置を前提としています。

保護装置の定格が 250 V、20 A を超えないことを確認下さい。

警告

此产品的短路（过载电流）保护由建筑物的供电系统提供，确保短路保护设备的额定电流不大于 250V,20A。

警告

此產品的短路（過載電流）保護由建築物的供電系統提供，確保短路保護設備的額定電流不大於 250V,20A。

Warnung

Dieses Produkt ist darauf angewiesen, dass im Gebäude ein Kurzschluss- bzw. Überstromschutz installiert ist. Stellen Sie sicher, dass der Nennwert der Schutzvorrichtung nicht mehr als: 250 V, 20 A beträgt.

¡Advertencia!

Este equipo utiliza el sistema de protección contra cortocircuitos (o sobrecorrientes) del edificio. Asegúrese de que el dispositivo de protección no sea superior a: 250 V, 20 A.

Attention

Pour ce qui est de la protection contre les courts-circuits (surtension), ce produit dépend de l'installation électrique du local. Vérifiez que le courant nominal du dispositif de protection n'est pas supérieur à :250 V, 20 A.

מוצר זה מסתמך על הגנה המותקנת במבנים למניעת קצר חשמלי. יש לוודא כי
המכשיר המגן מפני הקצר החשמלי הוא לא יותר מ-20 A, 250 V

هذا المنتج يعتمد على معدات الحماية من الدوائر القصيرة التي تم تثبيتها في
المبنى
تأكد من أن تقييم الجهاز الوقائي ليس أكثر من: 20A, 250V

경고 !

이 제품은 전원의 단락 (과전류) 방지에 대해서 전적으로 건물의 관련 설비에 의존합니다. 보호장치의 정격이 반드시 250V(볼트), 20A(암페어)를 초과하지 않도록 해야 합니다.

Waarschuwing

Dit product is afhankelijk van de kortsluitbeveiliging (overspanning) van uw elektrische installatie. Controleer of het beveiligde apparaat niet groter gedimensioneerd is dan 250V, 20A.

Power Disconnection Warning



Warning!

The system must be disconnected from all sources of power and the power cord removed from the power supply module(s) before accessing the chassis interior to install or remove system components.

電源切斷の警告

システムコンポーネントの取り付けまたは取り外しのために、シャーシー内部にアクセスするには、

システムの電源はすべてのソースから切斷され、電源コードは電源モジュールから取り外す必要があります。

警告

在你打开机箱并安装或移除内部器件前，必须将系统完全断电，并移除电源线。

警告

在您打開機殼安裝或移除內部元件前，必須將系統完全斷電，並移除電源線。

Warnung

Das System muss von allen Quellen der Energie und vom Netzanschlusskabel getrennt sein, das von den Spg.Versorgungsteilmodulen entfernt wird, bevor es auf den Chassisinnenraum zurückgreift, um Systemsbestandteile anzubringen oder zu entfernen.

¡Advertencia!

El sistema debe ser disconnected de todas las fuentes de energía y del cable eléctrico quitado de los módulos de fuente de alimentación antes de tener acceso el interior del chasis para instalar o para quitar componentes de sistema.

Attention

Le système doit être débranché de toutes les sources de puissance ainsi que de son cordon d'alimentation secteur avant d'accéder à l'intérieur du châssis pour installer ou enlever des composants de système.

אזהרה מפני ניתוק חשמלי

!אזהרה

יש לנתק את המערכת מכל מקורות החשמל ויש להסיר את כבל החשמלי מהספק לפני גישה לחלק הפנימי של המארז לצורך התקנת או הסרת רכיבים.

يجب فصل النظام من جميع مصادر الطاقة وإزالة سلك الكهرباء من وحدة امداد الطاقة قبل

الوصول إلى المناطق الداخلية للهيكل لتثبيت أو إزالة مكونات الجهاز

경고 !

시스템에 부품들을 장착하거나 제거하기 위해서는 새시 내부에 접근하기 전에 반드시 전원 공급장치로부터 연결되어있는 모든 전원과 전기코드를 분리해주어야 합니다.

Waarschuwing

Voordat u toegang neemt tot het binnenwerk van de behuizing voor het installeren of verwijderen van systeem onderdelen, dient u alle spanningsbronnen en alle stroomkabels aangesloten op de voeding(en) van de behuizing te verwijderen.

Equipment Installation



Warning!

Only trained and qualified personnel should be allowed to install, replace, or service this equipment.

機器の設置

トレーニングを受け認定された人だけがこの装置の設置、交換、またはサービスを許可されています。

警告

只有经过培训且具有资格的人员才能进行此设备的安装、更换和维修。

警告

只有經過受訓且具資格人員才可安裝、更換與維修此設備。

Warnung

Das Installieren, Ersetzen oder Bedienen dieser Ausrüstung sollte nur geschultem, qualifiziertem Personal gestattet werden.

¡Advertencia!

Solamente el personal calificado debe instalar, reemplazar o utilizar este equipo.

Attention

Il est vivement recommandé de confier l'installation, le remplacement et la maintenance de ces équipements à des personnels qualifiés et expérimentés.

אזהרה!

צוות מוסמך בלבד רשאי להתקין, להחליף את הציוד או לתת שירות עבור הציוד.

يجب أن يسمح فقط للموظفين المؤهلين والمدربين لتكيب واستبدال أو خدمة هذا الجهاز
경고!

훈련을 받고 공인된 기술자만이 이 장비의 설치, 교체 또는 서비스를 수행할 수 있습니다.

Waarschuwing

Deze apparatuur mag alleen worden geïnstalleerd, vervangen of hersteld door geschoold en gekwalificeerd personeel.

Restricted Area



Warning!

This unit is intended for installation in restricted access areas. A restricted access area can be accessed only through the use of a special tool, lock and key, or other means of security. (This warning does not apply to workstations).

アクセス制限区域

このユニットは、アクセス制限区域に設置されることを想定しています。

アクセス制限区域は、特別なツール、鍵と錠前、その他のセキュリティの手段を用いてのみ出入りが可能です。

警告

此部件应安装在限制进出的场所·限制进出的场所指只能通过使用特殊工具、锁和钥匙或其它安全手段进出的场所。

警告

此装置仅限安装於进出管制区域·进出管制区域係指僅能以特殊工具、鎖頭及鑰匙或其他安全方式才能進入的區域。

Warnung

Diese Einheit ist zur Installation in Bereichen mit beschränktem Zutritt vorgesehen. Der Zutritt zu derartigen Bereichen ist nur mit einem Spezialwerkzeug, Schloss und Schlüssel oder einer sonstigen Sicherheitsvorkehrung möglich.

¡Advertencia!

Esta unidad ha sido diseñada para instalación en áreas de acceso restringido. Sólo puede obtenerse acceso a una de estas áreas mediante la utilización de una herramienta especial, cerradura con llave u otro medio de seguridad.

Attention

Cet appareil doit être installée dans des zones d'accès réservés. L'accès à une zone d'accès réservé n'est possible qu'en utilisant un outil spécial, un mécanisme de verrouillage et une clé, ou tout autre moyen de sécurité.

אזור עם גישה מוגבלת

אזהרה!

יש להתקין את היחידה באזורים שיש בהם הגבלת גישה. הגישה ניתנת בעזרת כלי אבטחה בלבד (מפתח, מנעול וכד').

تم تخصيص هذه الوحدة لتركيبها في مناطق محظورة .
يمكن الوصول إلى منطقة محظورة فقط من خلال استخدام أداة خاصة،
قفل ومفتاح أو أي وسيلة أخرى للأمان

경고 !

이 장치는 접근이 제한된 구역에 설치하도록 되어있습니다. 특수도구, 잠금 장치 및 키, 또는 기타 보안 수단을 통해서만 접근 제한 구역에 들어갈 수 있습니다.

Waarschuwing

Dit apparaat is bedoeld voor installatie in gebieden met een beperkte toegang. Toegang tot dergelijke gebieden kunnen alleen verkregen worden door gebruik te maken van speciaal gereedschap, slot en sleutel of andere veiligheidsmaatregelen.

Battery Handling



Warning!

There is the danger of explosion if the battery is replaced incorrectly. Replace the battery only with the same or equivalent type recommended by the manufacturer. Dispose of used batteries according to the manufacturer's instructions.

電池の取り扱い

電池交換が正しく行われなかった場合、破裂の危険性があります。交換する電池はメーカーが推奨する型、または同等のものを使用下さい。使用済電池は製造元の指示に従って処分して下さい。

警告

電池更換不當會有爆炸危險。請只使用同類電池或制造商推荐的功能相当的電池更換原有電池。請按制造商的說明處理廢舊電池。

警告

電池更換不當會有爆炸危險。請使用製造商建議之相同或功能相當的電池更換原有電池。請按照製造商的說明指示處理廢棄舊電池。

Warnung

Bei Einsetzen einer falschen Batterie besteht Explosionsgefahr. Ersetzen Sie die Batterie nur durch den gleichen oder vom Hersteller empfohlenen Batterietyp. Entsorgen Sie die benutzten Batterien nach den Anweisungen des Herstellers.

Attention

Danger d'explosion si la pile n'est pas remplacée correctement. Ne la remplacer que par une pile de type semblable ou équivalent, recommandée par le fabricant. Jeter les piles usagées conformément aux instructions du fabricant.

¡Advertencia!

Existe peligro de explosión si la batería se reemplaza de manera incorrecta. Reemplazar la batería exclusivamente con el mismo tipo o el equivalente recomendado por el fabricante. Desechar las baterías gastadas según las instrucciones del fabricante.

אזהרה!

קיימת סכנת פיצוץ של הסוללה במידה והוחלפה בדרך לא תקינה. יש להחליף את הסוללה בסוג התואם מחברת יצרן מומלצת.

סילוק הסוללות המשומשות יש לבצע לפי הוראות היצרן.

هناك خطر من انفجار في حالة استبدال البطارية بطريقة غير صحيحة فعليك
استبدال البطارية
فقط بنفس النوع أو ما يعادلها كما أوصت به الشركة المصنعة
تخلص من البطاريات المستعملة وفقا لتعليمات الشركة الصانعة

경고!

배터리가 올바르게 교체되지 않으면 폭발의 위험이 있습니다. 기존 배터리와 동일하거나 제조사에서 권장하는 동등한 종류의 배터리로만 교체해야 합니다. 제조사의 안내에 따라 사용된 배터리를 처리하여 주십시오.

Waarschuwing

Er is ontploffingsgevaar indien de batterij verkeerd vervangen wordt. Vervang de batterij slechts met hetzelfde of een equivalent type die door de fabrikant aanbevolen wordt. Gebruikte batterijen dienen overeenkomstig fabrieksvorschriften afgevoerd te worden.

Redundant Power Supplies



Warning!

This unit might have more than one power supply connection. All connections must be removed to de-energize the unit.

冗長電源裝置

このユニットは複数の電源装置が接続されている場合があります。

警告

此部件连接的电源可能不止一个，必须将所有电源断开才能停止给该部件供电。

警告

此裝置連接的電源可能不只一個，必須切斷所有電源才能停止對該裝置的供電。

Warnung

Dieses Gerät kann mehr als eine Stromzufuhr haben. Um sicherzustellen, dass der Einheit kein Strom zugeführt wird, müssen alle Verbindungen entfernt werden.

¡Advertencia!

Puede que esta unidad tenga más de una conexión para fuentes de alimentación. Para cortar por completo el suministro de energía, deben desconectarse todas las conexiones.

Attention

Cette unité peut avoir plus d'une connexion d'alimentation. Pour supprimer toute tension et tout courant électrique de l'unité, toutes les connexions d'alimentation doivent être débranchées.

אם קיים יותר מספק אחד

אזהרה!

ליחדה יש יותר מחיבור אחד של ספק. יש להסיר את כל החיבורים על מנת לרוקן את היחידה.

قد يكون لهذا الجهاز عدة اتصالات بوحدات امداد الطاقة. يجب إزالة كافة الاتصالات لعزل الوحدة عن الكهرباء.

경고!

이 장치에는 한 개 이상의 전원 공급 단자가 연결되어 있을 수 있습니다. 이 장치에 전원을 차단하기 위해서는 모든 연결 단자를 제거해야만 합니다.

Waarschuwing

Deze eenheid kan meer dan één stroomtoevoeraansluiting bevatten. Alle aansluitingen dienen verwijderd te worden om het apparaat stroomloos te maken

Backplane Voltage



Warning!

Hazardous voltage or energy is present on the backplane when the system is operating. Use caution when servicing.

バックプレーンの電圧

システムの稼働中は危険な電圧または電力が、バックプレーン上にかかっています。

修理するには注意ください。

警告

当系统正在进行时·背板上有很危险的电压或能量·进行维修时务必小心。

警告

當系統正在進行時·背板上有很危險的電壓或能量·進行維修時務必小心。

Warnung

Wenn das System in Betrieb ist, treten auf der Rückwandplatine gefährliche Spannungen oder Energien auf. Vorsicht bei der Wartung.

¡Advertencia!

Quando el sistema está en funcionamiento, el voltaje del plano trasero es peligroso. Tenga cuidado cuando lo revise.

Attention

Lorsque le système est en fonctionnement, des tensions électriques circulent sur le fond de panier. Prendre des précautions lors de la maintenance.

מתח בפנל האחורי

אזהרה!

קיימת סכנת מתח בפנל האחורי בזמן תפעול המערכת. יש להיזהר במהלך העבודה.

هناك خطر من التيار الكهربائي أو الطاقة الموجودة على اللوحة عندما يكون النظام يعمل كن حذرا عند خدمة هذا الجهاز

경고!

시스템이 동작 중일 때 후면판 (Backplane) 에는 위험한 전압이나 에너지가 발생 합니다. 서비스 작업 시 주의하십시오.

Waarschuwing

Een gevaarlijke spanning of energie is aanwezig op de backplane wanneer het systeem in gebruik is. Voorzichtigheid is geboden tijdens het onderhoud.

Comply with Local and National Electrical Codes



Warning!

Installation of the equipment must comply with local and national electrical codes.

地方および国の電気規格に準拠

機器の取り付けはその地方および国の電気規格に準拠する必要があります。

警告

设备安装必须符合本地与本国电气法规。

警告

設備安裝必須符合本地與本國電氣法規。

Warnung

Die Installation der Geräte muss den Sicherheitsstandards entsprechen.

¡Advertencia!

La instalación del equipo debe cumplir con las normas de electricidad locales y nacionales.

Attention

L'équipement doit être installé conformément aux normes électriques nationales et locales.

תיאום חוקי החשמל הארצי

אזהרה!

התקנת הציוד חייבת להיות תואמת לחוקי החשמל המקומיים והארציים.

تركيب المعدات الكهربائية يجب أن يمتثل للقوانين المحلية والوطنية المتعلقة
بالكهرباء

경고!

현 지역 및 국가의 전기 규정에 따라 장비를 설치해야 합니다.

Waarschuwing

Bij installatie van de apparatuur moet worden voldaan aan de lokale en nationale elektriciteitsvoorschriften.

Product Disposal



Warning!

Ultimate disposal of this product should be handled according to all national laws and regulations.

製品の廃棄

この製品を廃棄処分する場合、国の関係する全ての法律・条例に従い処理する必要があります。

警告

本产品的废弃处理应根据所有国家的法律和规章进行。

警告

本產品的廢棄處理應根據所有國家的法律和規章進行。

Warnung

Die Entsorgung dieses Produkts sollte gemäß allen Bestimmungen und Gesetzen des Landes erfolgen.

¡Advertencia!

Al deshacerse por completo de este producto debe seguir todas las leyes y reglamentos nacionales.

Attention

La mise au rebut ou le recyclage de ce produit sont généralement soumis à des lois et/ou directives de respect de l'environnement. Renseignez-vous auprès de l'organisme compétent.

סילוק המוצר

אזהרה!

סילוק סופי של מוצר זה חייב להיות בהתאם להנחיות וחוקי המדינה.

عند التخلص النهائي من هذا المنتج ينبغي التعامل معه وفقا لجميع القوانين واللوائح الوطنية

경고!

이 제품은 해당 국가의 관련 법규 및 규정에 따라 폐기되어야 합니다.

Waarschuwing

De uiteindelijke verwijdering van dit product dient te geschieden in overeenstemming met alle nationale wetten en reglementen.

Hot Swap Fan Warning



Warning!

The fans might still be turning when you remove the fan assembly from the chassis. Keep fingers, screwdrivers, and other objects away from the openings in the fan assembly's housing.

ファン・ホットスワップの警告

シャーシから冷却ファン装置を取り外した際、ファンがまだ回転している可能性があります。ファンの開口部に、指、ドライバー、およびその他のものを近づけないで下さい。

警告!

警告! 危険的可移動性零件。请务必与转动的风扇叶片保持距离。当您从机架移除风扇装置·风扇可能仍在转动。小心不要将手指、螺丝起子和其他物品太靠近风扇。

警告

危險的可移動性零件。請務必與轉動的風扇葉片保持距離。當您從機架移除風扇裝置·風扇可能仍在轉動。小心不要將手指、螺絲起子和其他物品太靠近風扇。

Warnung

Die Lüfter drehen sich u. U. noch, wenn die Lüfterbaugruppe aus dem Chassis genommen wird. Halten Sie Finger, Schraubendreher und andere Gegenstände von den Öffnungen des Lüftergehäuses entfernt.

¡Advertencia!

Los ventiladores podran dar vuelta cuando usted quite ell montaje del ventilador del chasis. Mandtenga los dedos, los destornilladores y todos los objetos lejos de las aberturas del ventilador

Attention

Il est possible que les ventilateurs soient toujours en rotation lorsque vous retirerez le bloc ventilateur du châssis. Prenez garde à ce que doigts, tournevis et autres objets soient éloignés du logement du bloc ventilateur.

אזהרה!

חלקים נעים מסוכנים. התרחק מלהבי המאוורר בפעולה כאשר מסירים את חלקי המאוורר מהמארז, יתכן והמאווררים עדיין עובדים. יש להרחיק למרחק בטוח את

تحذير! أجزاء متحركة خطيرة. ابتعد عن شفرات المروحة المتحركة. من الممكن أن المراوح لا تزال تدور عند إزالة كتلة المروحة من الهيكل يجب إبقاء الأصابع ومفكات البراغي وغيرها من الأشياء بعيدا عن الفتحات في كتلة المروحة.
경고!

새시로부터 팬 조립품을 제거할 때 팬은 여전히 회전하고 있을 수 있습니다. 팬 조립품 외관의 열려있는 부분들로부터 손가락 및 스크류드라이버, 다른 물체들이 가까이 하지 않도록 배치해 주십시오.

Waarschuwing

Het is mogelijk dat de ventilator nog draait tijdens het verwijderen van het ventilatorsamenstel uit het chassis. Houd uw vingers, schroevendraaiers en eventuele andere voorwerpen uit de buurt van de openingen in de ventilatorbehuizing.

Power Cable and AC Adapter



Warning!

When installing the product, use the provided or designated connection cables, power cables and AC adaptors. Using any other cables and adaptors could cause a malfunction or a fire. Electrical Appliance and Material Safety Law prohibits the use of UL or CSA -certified cables (that have UL/CSA shown on the code) for any other electrical devices than products designated by Supermicro only.

電源コードと AC アダプター

製品を設置する場合、提供または指定された接続ケーブル、電源コードと AC アダプターを使用下さい。他のケーブルやアダプタを使用すると故障や火災の原因になることがあります。電気用品安全法は、UL または CSA 認定のケーブル (UL/CSE マークがコードに表記) を Supermicro が指定する製品以外に使用することを禁止しています。

警告

安装此产品时,请使用本身提供的或指定的或采购的连接线,电源线和电源适配器·包含遵照当地法规和安全要求的合规的电源线尺寸和插头.使用其它线材或适配器可能会引起故障或火灾.除了 Supermicro 所指定的产品,电气用品和材料安全法律规定禁止使用未经 UL 或 CSA 认证的线材。(线材上会显示 UL/CSA 符号)。

警告

安裝此產品時，請使用本身提供的或指定的或採購的連接線，電源線和電源適配器。包含遵照當地法規和安全要求的合規的電源線尺寸和插頭。使用其它線材或適配器可能會引起故障或火災。除了 Supermicro 所指定的產品，電氣用品和材料安全法律規定禁止使用未經 UL 或 CSA 認證的線材。(線材上會顯示 UL/CSA 符號)。

Warnung

Bei der Installation des Produkts, die zur Verfügung gestellten oder benannt Anschlusskabel, Stromkabel und Netzteile. Verwendung anderer Kabel und Adapter kann zu einer Fehlfunktion oder ein Brand entstehen. Elektrische Geräte und Material Safety Law verbietet die Verwendung von UL-oder CSA-zertifizierte Kabel, UL oder CSA auf der Code für alle anderen elektrischen Geräte als Produkte von Supermicro nur bezeichnet gezeigt haben.

¡Advertencia!

Al instalar el producto, utilice los cables de conexión previstos o designados, los cables y adaptadores de CA. La utilización de otros cables y adaptadores podría ocasionar un mal funcionamiento o un incendio. Aparatos Eléctricos y la Ley de Seguridad del Material prohíbe el uso de UL o CSA cables certificados que tienen UL o CSA se muestra en el código de otros dispositivos eléctricos que los productos designados por Supermicro solamente.

Attention

Lors de l'installation du produit, utilisez les bables de connection fournis ou désigné. L'utilisation d'autres cables et adaptateurs peut provoquer un dysfonctionnement ou un incendie. Appareils électroménagers et de loi sur la sécurité Matériel interdit l'utilisation de UL ou CSA câbles certifiés qui ont UL ou CSA indiqué sur le code pour tous les autres appareils électriques que les produits désignés par Supermicro seulement.

חשמליים ומתאמי AC

!אזהרה

כאשר מתקינים את המוצר, יש להשתמש בכבלים, ספקים ומתאמים AC אשר נועדו וסופקו לשם כך. שימוש בכל כבל או מתאם אחר יכול לגרום לתקלה או קצר חשמלי. על פי חוקי שימוש במכשירי חשמל וחוקי בטחות, קיים איסור להשתמש בכבלים המוסמכים ב- UL או ב- CSA (כשאר מופיע עליהם קוד של UL/CSA) עבור כל מוצר חשמלי אחר שלא צוין על ידי סופרמיקרו בלבד.

عند تركيب الجهاز يجب استخدام كابلات التوصيل، والكابلات الكهربائية
ومحولات التيار المتردد
التي . أن استخدام أي كابلات ومحولات أخرى يتسبب في حدوث عطل أو حريق.
تم توفيرها لك مع المنتج
الأجهزة الكهربائية ومواد قانون السلامة يحظر استخدام الكابلات UL أو CSA
معتمدة من قبل
لأي أجهزة كهربائية أخرى غير المنتجات المعينة من قبل Supermicro
(التي تحمل علامة UL/CSA)

경고 !

제품을 설치할 때에는 제공되거나 지정된 연결케이블과 전원케이블, AC 어댑터를 사용해야 합니다. 그 밖의 다른 케이블들이나 어댑터들은 고장 또는 화재의 원인이 될 수 있습니다. 전기용품안전법 (Electrical Appliance and Material Safety Law) 은 슈퍼마이크로에서 지정한 제품들 외에는 그 밖의 다른 전기 장치들을 위한 UL 또는 CSA 에서 인증한 케이블 (전선 위에 UL/CSA 가 표시) 들의 사용을 금지합니다.

Waarschuwing

Bij het installeren van het product, gebruik de meegeleverde of aangewezen kabels, stroomkabels en adapters. Het gebruik van andere kabels en adapters kan leiden tot een storing of een brand. Elektrisch apparaat en veiligheidsinformatiebladen wet verbiedt het gebruik van UL of CSA gecertificeerde kabels die UL of CSA die op de code voor andere elektrische apparaten dan de producten die door Supermicro alleen.

Chapter 3

Setup and Installation

3-1 Overview

This chapter covers the setup and installation of the MicroBlade module and its components.

3-2 Installing MicroBlade Modules

Up to twenty-eight MBI-6118G-T81X MicroBlade module may be installed into a single MBE-628E-xxx and MBE-314E-xxx MicroBlade module enclosure. MicroBlade modules with Windows and Linux operating systems may be mixed together in the same blade enclosure.

Powering Up a MicroBlade Module Unit

Each MicroBlade module unit may be powered on and off independently from the rest of the MicroBlade modules installed in the same enclosure. A MicroBlade module unit may be powered up in two ways:

- Press the power button on the MicroBlade module unit.
- Use IPMIView or the web-browser based management utility to apply power using the CMM MicroBlade module.

Powering Down a MicroBlade Module Unit

A MicroBlade module unit may be powered down in either of the following ways:

- Press the power button on the MicroBlade module unit.
- Use IPMIView or the web-browser based management utility to power down (if you have Operator or Admin privileges on the CMM).
- Use IPMITool when connected to the CMM to power down (if you have Operator or Admin privileges on the CMM).

Removing a MicroBlade Module Unit from the Enclosure

Although the MicroBlade module system may continue to run, individual MicroBlade modules should always be powered down before removing them from the enclosure.

Removing a MicroBlade Module Unit from the Enclosure

1. Power down the MicroBlade module unit (see "[Powering Down a MicroBlade Module Unit](#)" above).
2. Squeeze both handles to depress the red sections then pull out both handles completely and use them to pull the MicroBlade module unit from the enclosure.

Installing a Blade Unit into the Enclosure

Use the procedure below to install a blade unit into an enclosure.

Installing a MicroBlade Module Unit into the Enclosure

1. Slowly push the MicroBlade module unit into its bay with the handles fully pulled out (see [Figure 3-1](#)).
2. When the MicroBlade module stops, push the handles back in to their locked position, making sure the notches in both handles catch the lip of the enclosure.

Note: MicroBlade modules can be Hot-Plugged into the enclosure.

Caution: Use extreme caution when inserting a MicroBlade module into the enclosure. If the MicroBlade module's power connector becomes damaged, it can damage pins on other MicroBlade module bays that it is inserted into.

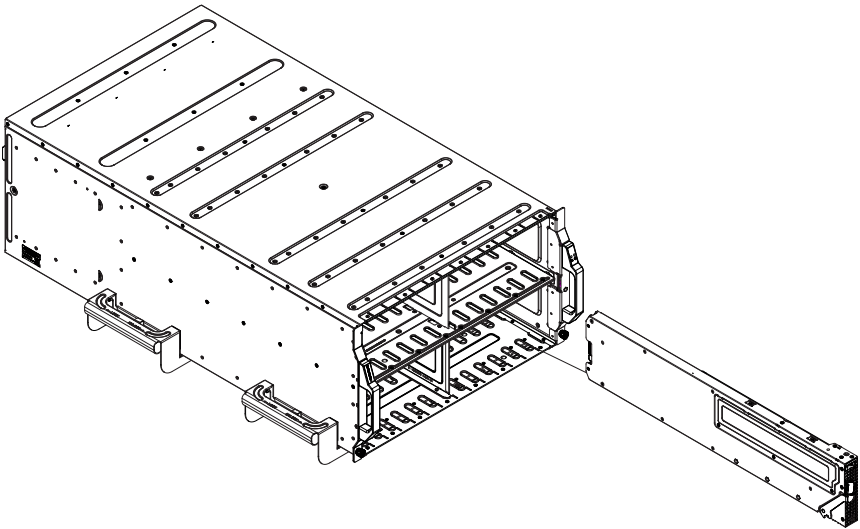
Figure 3-1. Inserting a MicroBlade Module into the Enclosure

3-3 Onboard Battery Installation

A battery is included on the serverboard to supply certain volatile memory components with power when power has been removed from the MicroBlade module. If this battery dies, it must be replaced with an equivalent CR2032 Lithium 3V battery. Dispose of used batteries according to the manufacturer's instructions. See [Figure 3-2](#) for a diagram of installing a new onboard battery.

Caution: There is a danger of explosion if the onboard battery is installed upside down, which reverses its polarities.

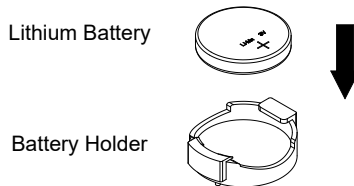
Figure 3-2. Installing the Onboard Battery

3-4 Memory Installation

The mainboard of each blade unit must be populated with DIMMs (Dual In-line Memory Modules) to provide system memory. **The DIMMs should all be of the same size and speed and from the same Super Micro authorized manufacturer due to compatibility issues.** See details below on supported memory and our web site (<http://www.supernmicro.com/products/microblade/>) for recommended memory.

Populating Memory Slots

The mainboard of a MBI-6118G-T81X blade module has four (4) memory slots, depending upon the blade model. For optimized memory bandwidth it is strongly recommended that **ALL** memory slots in this MicroBlade module be populated by DIMMs. DIMM layout is shown below in [Figure 3-3](#).

Figure 3-3. 4-slot DIMM Numbering

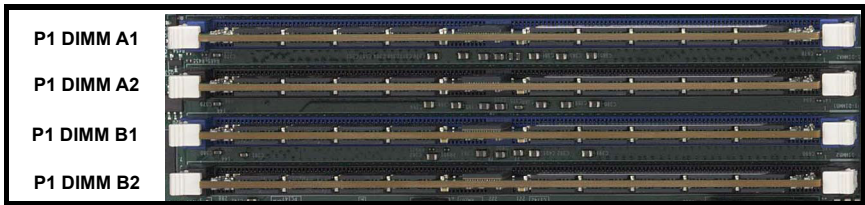

Note: Though multiple DIMM memory module types and speeds may be supported, you need to use DIMM memory modules of the same speed and type.

Note: For an optimized memory bandwidth, it is recommended that you populate the memory modules in sets of four (4) DIMMs.

DIMM Installation

Caution: Exercise extreme care when installing or removing DIMM modules to prevent any possible damage.

Installing DIMM Memory Modules

1. Power down the blade module (see "[Powering Down a MicroBlade Module Unit](#)" on [page 3-1](#)).
2. Remove the blade from the enclosure.
3. Remove the air shroud that covers the DIMM slots.
4. Insert each DIMM vertically into its slot, starting with slots A1 and A2. Pay attention to the notch along the bottom of the module to prevent inserting the DIMM incorrectly (see [Figure 3-4](#)).

Figure 3-4. Installing a DIMM into a Memory Slot

To Install: Insert module vertically and press down until it snaps into place. Pay attention to the bottom notch.

To Remove: Use your thumbs to gently push each release tab outward to free the DIMM from the slot.

Note: The notch should align with the receptive key point on the

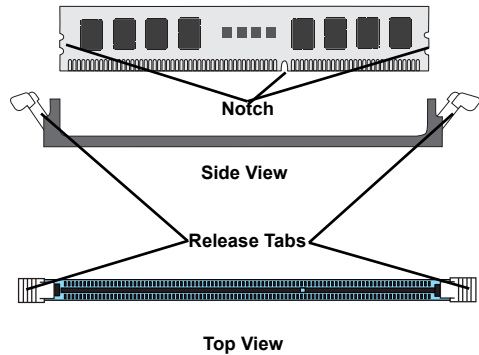

5. Gently press down on the DIMM until it snaps into place in the slot. Repeat for all modules.
6. Replace the air shroud and install the blade module back into the enclosure.
7. Power up the blade unit (see ["Powering Up a MicroBlade Module Unit" on page 3-1](#)).

3-5 Hard Disk Drive Installation

Up to four 2.5" SATA3 (6 Gbps) HDD/SSD disk drives (two HDD/SSD and two SSD) can be installed in the MicroBlade module, and cannot be removed or replaced without powering down the blade unit they reside in. A blade module needs a hard disk drive with an operating system installed to operate. RAID 0, 1 and 10 are supported.

3-6 Installing the Operating System

An operating system (OS) must be installed on each MicroBlade module. Blades with Microsoft Windows OS and blades with Linux OS can both occupy and operate within the same blade enclosure. Refer to the SuperMicro web site for a complete list of supported operating systems.

There are several methods of installing an OS to the blade modules.

Installing with a SATA-DOM Module

The MBI-6118G-T81X MicroBlade module contains a SATA-DOM socket for each node on the serverboard. The operating system can be installed separately onto the SATA-DOM module, which when plugged into the SATA-DOM socket of a node of the MBI-6118G-T81X MicroBlade module, can be used as the system's operating system just as if it was a hard disk drive of the system.

Installing via PXE Boot

PXE (Preboot Execution Environment) is used to boot a computer over a network. To install the OS via PXE, the following conditions must be met:

1. The PXE BOOT option in BIOS must be enabled.
2. A PXE server has been configured (this can be another blade in the system).
3. The PXE server must be connected over a network to the blade to be booted.
4. The blade has only non-partitioned/unformatted hard drives installed and no bootable devices attached to it.

Once these conditions are met, make sure the PXE server is running. Then turn on the blade on which you wish to boot and/or install the OS. The BIOS in the blade will look at all bootable devices and finding none will connect to the PXE server to begin the boot/install.

Installing via Virtual Media (Drive Redirection)

You can install the OS via Virtual Media through either the *IPMIview* (Java based client utility), *IPMITool* or the *Web-based Management Utility*. With this method, the OS is installed from an ISO image that resides on another system/blade.

Chapter 4

MicroBlade Module Features

Figure 4-1. MBI-6118G-T81X Blade Unit Front View



This chapter describes the MBI-6118G-T81X MicroBlade module unit. Installation and maintenance should be performed by experienced technicians only.

See [Figure 4-1](#) for a front view of the blade unit and [Table 4-1](#) for its features.

Table 4-1. MBI-6118G-T81X Blade Unit Features

Feature	Description
Processors	Supports a single Intel Xeon D-1581 embedded in a FCBGA 1667 socket on the serverboard
Memory	Supports up to 128 GB of DDR4 2133/2400 MHz speed and 32 GB size, 1.2 V voltage ECC VLP RDIMM memory in four 288-pin DIMM sockets
Storage	Supports up to four 2.5" SATA3 (6 Gbps) HDD/SSD disk drives (two HDD/SSD and two SSD)
BIOS	128 Mb SPI Flash EEPROM with AMI® BIOS
Ports	One SATA3 HDD/SSD port

4-1 Control Panel

Each MicroBlade module has a similar control panel (Figure) with power on/off button, reset button and LEDs on the front left side of the module. The numbers mentioned in Figure are described in Table 4-2.

Figure 4-2. Blade Control Panel

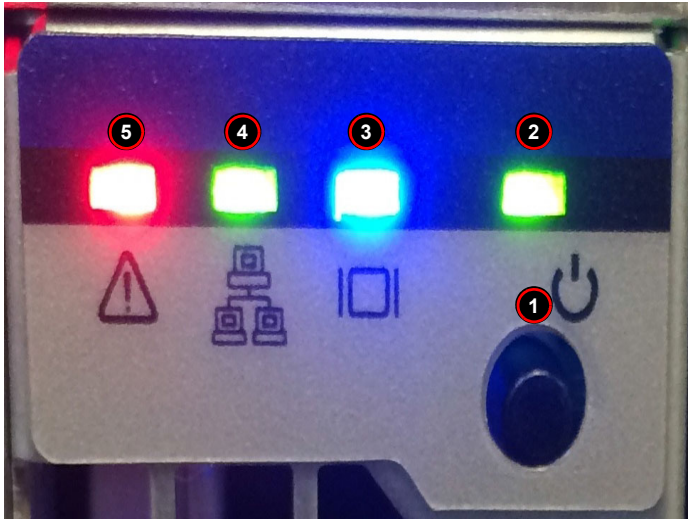

Table 4-2. Blade Control Panel

Item	Function	State	Description
1	Power Button	N/A	Turns MicroBlade module on and off
2	Power LED	Green	Indicates power status "On"
		Amber	Before the BMC is ready, the Amber LED will blink until the last node out of the four is ready.
3	KVM/UID LED (Blue)	Steady On	Indicates that KVM has been initialized on this blade module
		Flashing	Serves as a UID indicator (the UID function is activated with a management program)
4	Network LED (Green)	Flashing Green	Flashes on and off to indicate traffic (Tx and RX data) on the LAN connection to this blade module.
	Network LED (Orange)	Flashing Orange	Flashes on and off to indicate traffic over the network (when present in the system)
5	System Fault LED (Red)	Steady On	This LED illuminates red when a fatal error occurs. This may be the result of a memory error, a VGA error or any other fatal error that prevents the operating system from booting up.

Power Button

Each MicroBlade module has its own power button so that individual blade units within the enclosure may be turned on or off independently of the others. Press the power button (#1) to turn on the blade server. The power LED (#3) will turn green. To turn off, press and hold the power button for >4 seconds and the power LED will turn orange.

LED Indicators

Blade module LEDs are described below in [Table 4-3](#).

Table 4-3. Blade Module LED Indicators

LED	State	Description
Power LED	Green	Power On
	Amber	Standby
System Fault LED (Red)	Steady On	This LED illuminates red when a fatal error occurs. This may be the result of a memory error, a VGA error or any other fatal error that prevents the operating system from booting up.

4-2 Serverboard

The serverboard of the MBI-6118G-T81X MicroBlade module unit is a proprietary design, which is based on the Intel Intel Xeon D-1581 processor. See [Figure 4-4](#) for a block diagram of this chipset, [Figure 4-3](#) for a view of the B1SD1-16C-TF serverboard and [Figure 4-5](#) for an exploded view diagram of the MicroBlade module unit.

Figure 4-3. B1SD1-16C-TF Serverboard

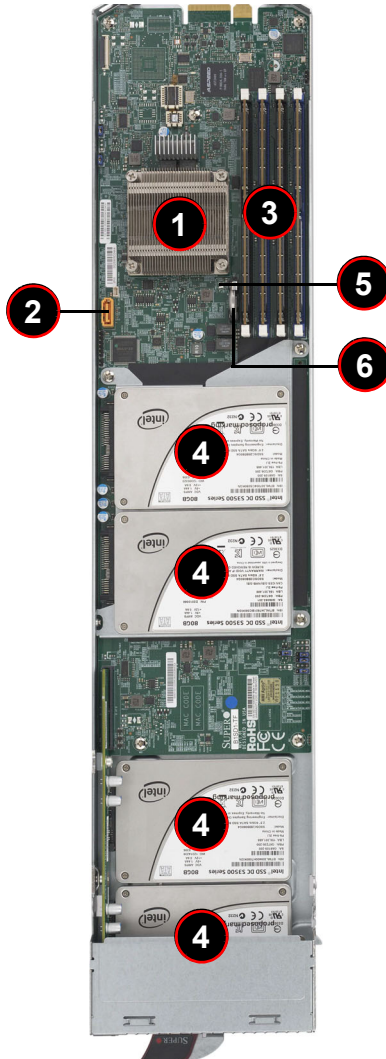

CMOS Clear

JBT1 is used to clear CMOS and will also clear any passwords. JBT1 consists of two contact pads located near the BIOS chip.

Clearing CMOS

1. First power down the blade and remove it from the enclosure.
2. Short the CMOS pads with a metal object such as a small screwdriver.
3. Install the blade back into the enclosure and power it on.

4-3 Blade Unit Components

Figure 4-5. Exploded View of a MBI-6118G-T81X MicroBlade Module

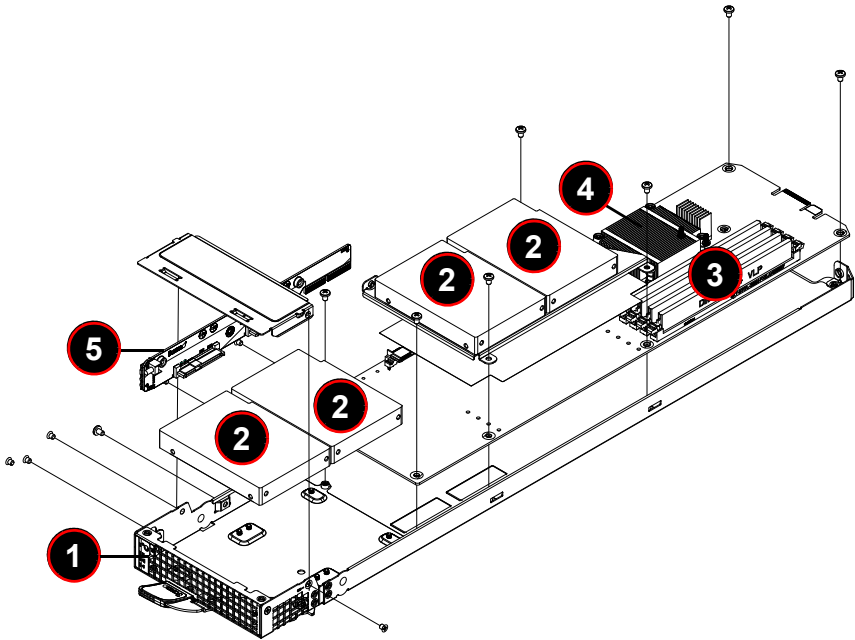

Table 4-5. Main Components of a MBI-6118G-T81X Blade Module

Item	Description
1	Blade Unit/Module
2	2.5" Hard Drives (4)
3	DIMM slots (4)
4	CPU/Heatsinks (4)
5	Hard Drive Backplane

Memory Support

The MBI-6118G-T81X MicroBlade module supports up to 32 GB of ECC VLP RDIMM, 32 GB size DIMM memory in four 288-pin sockets. See [Section 3-4: Memory Installation on page 3-4](#) for further details on serverboard memory installation.

Hard Disk Drives

The MBI-6118G-T81X MicroBlade module accommodates up to four 2.5" SATA3 HDD/SSD drives. The drives cannot be removed or replaced without powering down the blade unit they reside in. See [Chapter 1](#) for information on RAID Setup.

WARNING: Enterprise level hard disk drives are recommended for use in Supermicro chassis and servers. For information on recommended HDDs, visit the Supermicro Web site at <http://www.supermicro.com/products/nfo/storage.cfm>

Chapter 5

BIOS

5-1 Introduction

This chapter describes the BIOS for the MBI-6118G-T81X MicroBlade module. This MicroBlade module uses a 128 Mb SPI Flash EEPROM with AMI® BIOS™ that is stored in a flash chip. This BIOS can be easily upgraded using a floppy disk-based program.

Note: Due to periodic changes to the BIOS, some settings may have been added or deleted and might not yet be recorded in this manual. Please refer to the <http://www.supermicro.com/products/microblade/module/> web site for further details on BIOS setup and the BIOS menus for your MicroBlade module.

System BIOS

BIOS stands for Basic Input Output System. The 128 Mb SPI Flash EEPROM with AMI® BIOS flash chip stores the system parameters, types of disk drives, video displays, in the CMOS. The CMOS memory requires very little electrical power. When the blade unit is turned off, a backup battery provides power to the BIOS flash chip, enabling it to retain system parameters. Each time the blade is powered on it is configured with the values stored in the BIOS ROM by the system BIOS, which gains control at boot up.

How To Change the Configuration Data

The CMOS information that determines the system parameters may be changed by entering the BIOS Setup utility. This Setup utility can be accessed by pressing the <DELETE> key at the appropriate time during system boot. (See "Starting the Setup Utility" below.)

Starting the Setup Utility

Normally, the only visible POST (Power-On Self-Test) routine is the memory test. As the memory is being tested, press the <DELETE> key to enter the main menu of the BIOS Setup utility. From the main menu, you can access the other setup screens, such as the Security and Power menus.

Caution: To prevent possible boot failure, do not shut down or reset the system while updating the BIOS.

5-2 BIOS Updates

It may be necessary to update the BIOS used in the blade modules on occasion. However, it is recommended that you not update BIOS if you are not experiencing problems with a blade module.

Updated BIOS files are located on our web site (<http://www.supernmicro.com/products/microblade>). Please check the current BIOS revision and make sure it is newer than the revision you have.

To upload a new BIOS update, simply follow the Help instructions in the IPMI BIOS Upload page (Figure 5-1) when you press the Help button at the top of the page. This procedure will get you a BIOS Update.

Figure 5-1. IPMI BIOS Upload Page with Help Upload Procedure

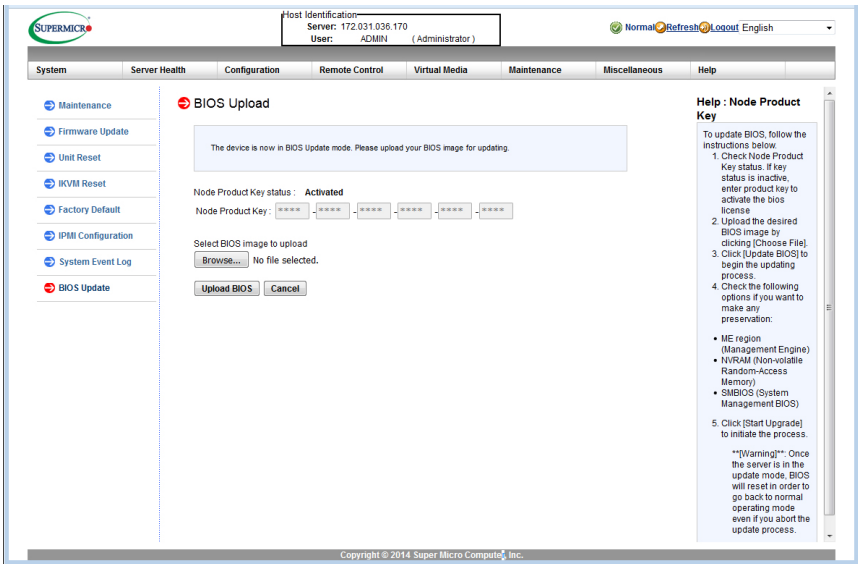

Flashing BIOS

Use the procedures below to “Flash” your BIOS with a new update using the USB ports on the CMM module or by use of a Floppy Image file.

Flashing a BIOS using the USB Ports on the CMM:

1. Copy the contents of the zip file to a bootable USB pen drive.
2. Connect your bootable USB pen drive to one of the two USB slots on the CMM (located on the back side of the enclosure).
3. Boot to the USB pen drive and go to the directory where you saved the contents of the zip file.

4. Type **flash filename.rom** (replace *filename.rom* by the actual ROM file name).

Flashing a BIOS using a Floppy Image File

This method must be performed remotely.

1. Copy the image file from the zip file to your desktop.
2. Use the web browser or IPMIView to access your CMM remotely using its IP Address.
3. Go to the VIRTUAL MEDIA menu and select FLOPPY IMAGE UPLOAD.
4. BROWSE or OPEN to locate the **.img* file on your desktop and select it.
5. Press the UPLOAD button and wait a few seconds for the image to upload to the CMM.
6. Once the upload finishes, turn on the blade module and press to enter the BIOS setup utility.
7. In the BOOT MENU, bring **USB LS120: PEPPCMM VIRTUAL DISC 1** to the top of the boot priority list.
8. Exit while saving the changes. The blade module will boot to the virtual media (floppy image) **A:\>**.
9. Type **flash filename.rom**.

Note: Replace *filename.rom* by the actual ROM file name (such as **B8DTE142.rom** for example) in the command.

5-3 Running Setup

Note: Default settings are in **bold** text unless otherwise noted.

The BIOS setup options described in this section are selected by choosing the appropriate text from the MAIN BIOS SETUP screen. All displayed text is described in this section, although the screen display is often all you need to understand how to set the options.

When you first power on the computer, the BIOS is immediately activated.

While the BIOS is in control, the Setup program can be activated in one of two ways:

1. By pressing <DELETE> immediately after turning the system on, or
2. When the message **Press the <Delete> key to enter Setup** appears briefly at the bottom of the screen during the POST, press the <DELETE> key to activate the main SETUP menu:

5-4 Main BIOS Setup

Figure 5-2. BIOS Setup Screen

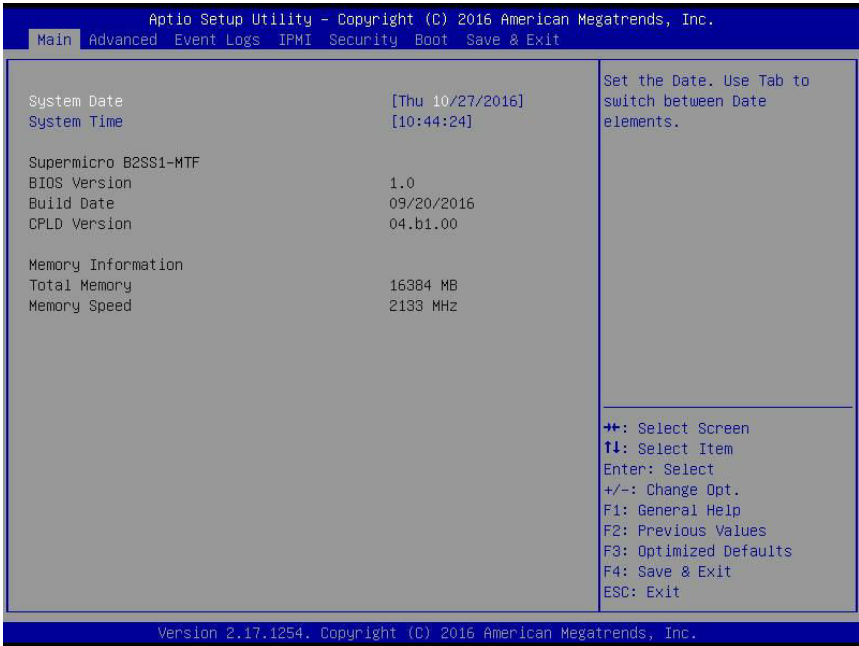

All Main Setup options are described in this section. Use the UP/DOWN arrow keys to move among the different settings in each menu. Use the LEFT/RIGHT arrow keys to change the options for each setting. Press the <ESC> key to exit the CMOS SETUP menu. The next section describes in detail how to navigate through the menus. Items that use sub-menus are indicated with the ► icon. With the item highlighted, press the <ENTER> key to access the sub-menu.

Menu options found in the MAIN BIOS SETUP menu are described in [Table 5-1](#).

Table 5-1. Main BIOS Setup Menu Options

Menu Option	Description
System Date	Using the arrow keys, highlight the month, day and year fields, and enter the correct data for the system date. Press the <Enter> key to save the data.
System Time	To set the system date and time, key in the correct information in the appropriate fields. Then press the <Enter> key to save the data.
BIOS Information	BIOS static display information including the serverboard number, SMC version, SMC Build Date and Memory Information is also shown on the screen.

5-5 Advanced Setup

Figure 5-3. Advanced Setup Screen

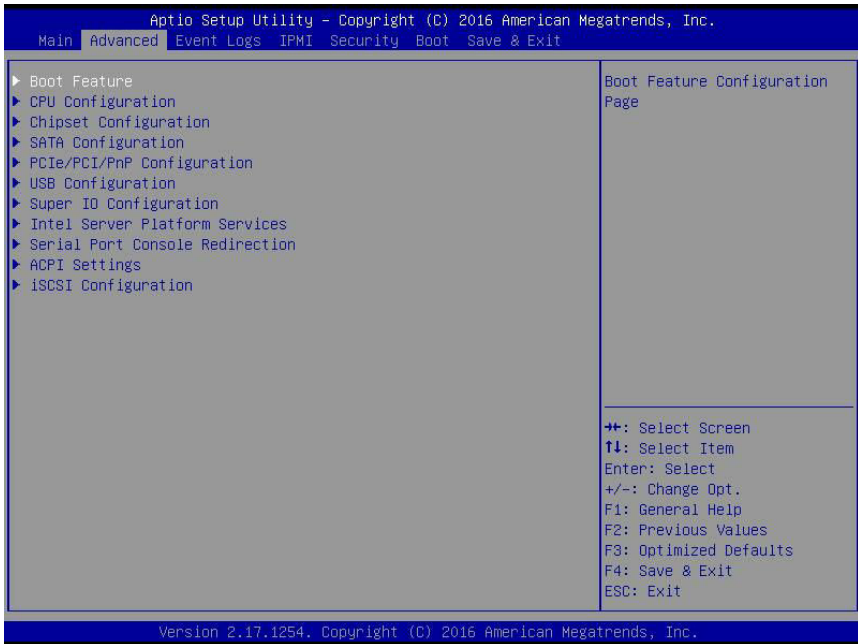

Choose **Advanced** from the BIOS Setup Utility main menu with the arrow keys to display the **ADVANCED SETUP** menu. The items with a triangle beside them are sub-menus that can be accessed by highlighting the item and pressing <ENTER>. Options for PIR settings are displayed by highlighting the setting option using the arrow keys and pressing <ENTER>.

Table 5-2 describes all sub-menus found in the **ADVANCED SETUP** menu.

Table 5-2. Advanced Setup Menu Options

Sub-menu	Description
▶ Boot Feature	See Table 5-3 for a description of BIOS setup menu options in this sub-menu.
▶ CPU Configuration	See Table 5-4 for a description of BIOS setup menu options in this sub-menu.
▶ Chipset Configuration	See Table 5-5 for a description of BIOS setup menu options in this sub-menu.
▶ SATA Configuration	See Table 5-6 for a description of BIOS setup menu options in this sub-menu.
▶ PCIe/PCI/PnP Configuration	See Table 5-7 for a description of BIOS setup menu options in this sub-menu.
▶ USB Configuration	See Table 5-8 for a description of BIOS setup menu options in this sub-menu.
▶ Super IO Configuration	See Table 5-9 for a description of BIOS setup menu options in this sub-menu.
▶ Intel Server Platform Services	See Table 5-10 for a description of BIOS setup menu options in this sub-menu.
▶ Serial Port Console Redirection	See Table 5-11 for a description of BIOS setup menu options in this sub-menu.
▶ ACPI Settings	See Table 5-12 for a description of BIOS setup menu options in this sub-menu.
▶ iSCSI Configuration	See Table 5-13 for a description of BIOS setup menu options in this sub-menu.

Table 5-3. Boot Feature Sub-menu

Menu Option	Description
Boot Feature	
Quiet Boot	Use this feature to select the screen display between the POST messages and the OEM logo upon boot-up. Select Disabled to display the POST messages. Select Enabled to display the OEM logo instead of the normal POST messages. The options are Enabled and Disabled.
AddOn ROM Display Mode	Use this feature to set the display mode for the Option ROM. Select Keep Current to display the current AddOn ROM setting. Select Force BIOS to use the Option ROM display set by the system BIOS. The options are Force BIOS and Keep Current.
Bootup NumLock State	Use this feature to set the Power-on state for the <Numlock> key. The options are Off and On .
Wait for 'F1' If Error	Use this feature to force the system to wait until the 'F1' key is pressed if an error occurs. The options are Disabled and Enabled .

Table 5-3. Boot Feature Sub-menu (Continued)

Menu Option	Description
INT19 Trap Response	Interrupt 19 is the software interrupt that handles the boot disk function. When this item is set to Enabled, the ROM BIOS of the host adapters will "capture" Interrupt 19 at bootup and allow the drives that are attached to these host adapters to function as bootable disks. If this item is set to Disabled, the ROM BIOS of the host adapters will not capture Interrupt 19, and the drives attached to these adapters will not function as bootable devices. The options are Immediately and Postponed.
Re-try Boot	This option allows you to decide how to retry boot devices which fail to boot. Options include Disabled , Legacy Boot or EFI Boot.
Install Windows 7 USB Support	Enabling this option installs Windows 7 USB keyboard/mouse support. After installing Windows 7 & XHCI driver please set to Disabled. Options include Disabled or Enabled.
Power Configuration	
Watch Dog Function	If enabled, the Watch Dog Timer will allow the system to reboot when it is inactive for more than 5 minutes. The options are Enabled and Disabled .
Power Button Function	This feature controls how the system shuts down when the power button is pressed. Select 4_Seconds_Override for the user to power off the system after pressing and holding the power button for 4 seconds or longer. Select Instant Off to instantly power off the system as soon as the user presses the power button. The options are 4 Seconds Override and Instant Off .

Table 5-4. CPU Configuration Sub-menu

Menu Option	Description
Processor Information	Static processor information is displayed at the top of the menu.
Hyper-threading	This option is enabled for Windows XP and Linux (OS optimized for Hyper-Threading Technology), and disabled for other OS (OS not optimized for Hyper-Threading Technology). When disabled only one thread per enabled core is enabled. Options include Enabled and Disabled.
Active Processor Cores	Use this feature to specify the number of cores to enable in each processor package. Options include All , 1, 2 and 3.
Execute Disable Bit	XD can prevent certain classes of malicious buffer overflow attacks when combined with a supporting OS (such as Windows Server 2003). Options are Enabled and Disabled.
Intel Virtualization Technology	When this feature is enabled, a VMM can utilize the additional hardware capabilities provided by Vanderpool Technology. Options include Enabled and Disabled.
Hardware Prefetcher	Use this feature to turn on/off the Mid Level Cache (L2) streamer prefetcher. Options include either Enable or Disable.
Adjacent Cache Line Prefetch	Use this feature to turn on/off prefetching of adjacent cache lines. Options include either Enable or Disable.
CPU AES	This feature allows you to Enable/Disable CPU Advanced Encryption Standard instructions.

Table 5-4. CPU Configuration Sub-menu (Continued)

Menu Option	Description
Boot Performance Mode	This feature allows you to select the performance state that the BIOS will set before OS hand-off. Options include Power Saving, Max Non-Turbo Performance and Turbo Performance.
Disable PROCHOT# Output	This option allows you to Enable or Disable PROCHOT# output for your system.
Bi-directional PROCHOT#	When a processor thermal sensor trips for either core, the PROCHOT# will be driven. If bi-direction is enabled, external agents can drive PROCHOT# to throttle the processor. Options include Enabled or Disabled.
Hardware P-States (HWP)	This option Enables/Disables Intel Speed Shift Technology support. Enabling will expose the CPPC v2 interface to allow for hardware controlled P-states.
Intel (R) Speed Shift Technology	This feature Enables/Disables Intel Speed Shift Technology support. Enabling will expose the CPPC v2 interface to allow for hardware controlled P-states.
Intel (R) SpeedStep (tm)	This feature allows you to specify more than two frequency ranges to be supported. Options include Enabled or Disabled.
Turbo Mode	This feature Enables or Disables Turbo Mode for your system.
Package Power Limit MSR Lock	This feature Enables/Disables locking of the Package Power Limit settings. When enabled, the PACKAGE_POWER_LIMIT MSR will be locked and a reset will be required to unlock the register.
Power Limit 1 Override	This feature Enables/Disables Power Limit 1 Override. If this option is disabled, BIOS will program the default values for Power Limit 1 and Power Limit 1 Time Window.
Power Limit 2 Override	This feature Enables/Disables Power Limit 2 Override. If this option is disabled, BIOS will program the default values for Power Limit 2.
Power Limit 2	This feature specifies a value in Milliwatts and step-size in 125mW. If the value is 0, BIOS will program this value as 1.25*TDP. The processor applies control policies such that the package power does not exceed this limit.
1-Core Ratio Limit Override	This feature specifies the core ratio limit for 1 core active. A value of 0 means using the factory-configured value.
2-Core Ratio Limit Override	This feature specifies the core ratio limit for 2 cores active. A value of 0 means using the factory-configured value.
3-Core Ratio Limit Override	This feature specifies the core ratio limit for 3 cores active. A value of 0 means using the factory-configured value.
4-Core Ratio Limit Override	This feature specifies the core ratio limit for 4 cores active. A value of 0 means using the factory-configured value.
CPU C-States	This feature Enables or Disables CPU C-states.
Enhanced C-States	This feature enables or disables C1E. When Enabled , the CPU will switch to a minimum speed when all cores enter C-State.
C-State Auto Demotion	This feature configures C-State Auto Demotion. Options include Disabled, C1, C3 or C1 and C3 .

Table 5-4. CPU Configuration Sub-menu (Continued)

Menu Option	Description
C-State Un-Demotion	This feature configures C-State Un-demotion. Options include Disabled, C1, C3 or C1 and C3 .
Package C-State Demotion	This feature allows you to Enable or Disable Package C-State Demotion for your system.
Package C-State Un-Demotion	This feature allows you to Enable or Disable C-State Un-demotion for your system.
C-State Pre-Wake	Use this feature to set bit 30 of POWER_CTL_MSR(0X1FC) to 1 in order to disable the C-State Pre-Wake. Options include Enabled or Disabled.
Package C-State Limit	Use this feature to package a C-State Limit. Options include C0/C1, C2, C3, C6, C7, C7s, C8 and Auto .
► CPU Thermal Configuration	This sub-menu allows you specify CPU Thermal Configuration options.
CPU DTS	When this feature is Disabled , the ACPI thermal management uses EC reported temperature values. When Enabled, ACPI thermal management uses the DTS SMM mechanism to obtain CPU temperature values, and DTS SMM is used to handle out of spec conditions.
ACPI 3.0 T-States	Use this feature to Enable/ Disable ACPI 3.0 T-States.

Table 5-5. Chipset Configuration Sub-menu

Menu Option	Description
► System Agent (SA) Configuration	This sub-menu allows you to configure System Agent (SA) parameters.
System Agent Configuration Information	This static display shows static information for the system agent configuration.
VT-d	Use this feature to Enable/Disable VT-d capability for your system.
SW Guard Extensions (SGX)	This feature enables or disables Software Guard Extensions (SGX) in your system. Options include Disabled, Enabled or Software Controlled.
Select Owner EPOCH Input Type	Th is feature selects one of three EPOCH modes (each is 64-bit). These are No Change in Owner EPOCHs , Change to New Random Owner EPOCHs or Manual User Defined Owner EPOCHs. After you enter EPOCH values manual, the values will not be visible for security reasons.
PRMRR Size	This feature allows you to set the PRMRR Size. Options include Auto , 32MB, 64MB and 128MB.
► Graphics Configuration	This sub-menu displays options for the Graphics Configuration.
Primary Display	This selects which of the IGFX/PEG/PCI graphics devices should be the primary display, or selects SG for "Switchable Gfx". Options include Auto, PEG or PCIE .
Internal Graphics	This option allows you to keep IGFX enabled based upon the setup options. Options include Auto, Disabled and Enabled .

Table 5-5. Chipset Configuration Sub-menu (Continued)

Menu Option	Description
GTT Size	This option selects the GTT size. Options include 2MB, 4MB and 8MB .
Aperture Size	This option selects the Aperture Size. Note that above 4GB MMIO BIOS assignment is automatically enabled when selecting the 2048MB aperture. To use this feature, please disable CSM support. Options include aperture sizes from 128MB~4096MB with a default of 256MB .
DVMT Pre-Allocated	This option selects the DVMT 5.0 pre-allocated (fixed) graphics memory size used by the internal graphics device. Options include memory sizes from 32M~60M, with a default of 32M .
DVMT Total IGFX Memory	Use this option to select DVMT 5.0 total graphic memory size used by the internal graphics device. Options include 128M, 256M and Max.
IGFX Low Power Mode	This option is applicable for SFF, and the options are either Enabled or Disabled.
PM Support	This option allows you to Enable or Disable PM support.
PAVP Enable	This option allows you to Enable or Disable PAVP.
►DMI/OPI Configuration	This sub-menu displays options for DMI/OPI Configuration.
DMI Information	This static display shows DMI Information.
DMI VC1 Control	This feature allows you to Enable/ Disable DMI VC1 controls.
DMI VCm Control	This feature allows you to Enable / Disable DMI VCm controls.
CPU DMI Link ASPM Control	This feature allows you to enable/disable the control of Active State Power Management on the SA side of the DMI Link. Options include L1 or Disabled.
DMI Extended Sync Control	Use this feature to Enable or Disable DMI Extended Synchronization for your system.
DMI De-Emphasis Control	Use this feature to configure the De-emphasis control on DMI. Options include -6 dB or -3.5 dB .
►PEG Port Configuration	This sub-menu displays options for PEG Port Configuration.
P1_M.2_1 PCI-E3.OX4	This shows static information for the P1_M.2_1 PCI-E3.OX4 PEG port.
P1_M.2_1 PCI-E3.OX4 Max Link Speed	Use this feature to configure P1_M.2_1 PCI-E3.OX4 Max Speed. Options include Auto , Gen1, Gen2 and Gen3.
P1_M.2_1 PCI-E3.OX4 Max Payload Size	Use the feature to select the P1_M.2_1 PCI-E3.OX4 Max Payload Size. Options include Auto , 128 TLP and 256 TLP.
P1_M.2_1 PCI-E3 ASPM Support	This controls ASPM support for the P1_M.2_1 PCI-E3 port. This has no effect if PEG is not the currently active device. Options include Disabled, Auto , ASPM L0s, APSM L1 and ASPM L0s & L1.

Table 5-5. Chipset Configuration Sub-menu (Continued)

Menu Option	Description
P1_M.2_1 PCI-E3.OX4 Slot Power Limit Value	Use this number field to set the upper limit on power supplied by the slot. The power limit (in Watts) is calculated by multiplying this value by the slot's Power Limit Scale. Values range from 0-255 with a default of 75 .
P1_M.2_1 PCI-E3.OX4 Slot Power Limit Scale	Use this feature to select the scale used for the Slot Power Limit Value. Options include 1.0x , 0.1xm, 0.01x and 0.001x.
P1_M.2_2 PCI-E3.OX4	This shows static information for the P1_M.2_2 PCI-E3.OX4 PEG port.
P1_M.2_2 PCI-E3.OX4 Max Link Speed	Use this feature to configure P1_M.2_2 PCI-E3.OX4 Max Speed. Options include Auto , Gen1, Gen2 and Gen3.
P1_M.2_2 PCI-E3.OX4 Max Payload Size	Use the feature to select the P1_M.2_2 PCI-E3.OX4 Max Payload Size. Options include Auto , 128 TLP and 256 TLP.
P1_M.2_2 PCI-E3.OX4 ASPM Support	This controls ASPM support for the P1_M.2_2 PCI-E3.OX4 port. This has no effect if PEG is not the currently active device. Options include Disabled, Auto , ASPM L0s, APSM L1 and ASPM L0s & L1.
P1_M.2_2 PCI-E3.OX4 Slot Power Limit Value	Use this number field to set the upper limit on power supplied by the slot. The power limit (in Watts) is calculated by multiplying this value by the slot's Power Limit Scale. Values range from 0-255 with a default of 75 .
P1_M.2_2 PCI-E3.OX4 Slot Power Limit Scale	Use this feature to select the scale used for the Slot Power Limit Value. Options include 1.0x , 0.1xm, 0.01x and 0.001x.
X710-BM2	This shows static information for the X710-BM2 PEG port.
X710-BM2 Max Link Speed	Use this feature to configure X710-BM2 Max Speed. Options include Auto , Gen1, Gen2 and Gen3.
X710-BM2 Max Payload Size	Use the feature to select the X710-BM2 Max Payload Size. Options include Auto , 128 TLP and 256 TLP.
X710-BM2 ASPM Support	This controls ASPM support for the X710-BM2 port. This has no effect if PEG is not the currently active device. Options include Disabled, Auto , ASPM L0s, APSM L1 and ASPM L0s & L1.
Program PCIe ASPM After OPROM	Use this feature to enable/disable the Program PCIe ASPM after OPROM. When Enabled , the PCIe ASPM will be programmed after OPROM. If Disabled, the PCIe ASPM will be programmed before OPROM.
►Memory Configuration	This sub-menu displays and provides options to change the memory settings.
Maximum Memory Frequency	Use this setting to restrict the maximum memory frequency below the enforced POR. Frequencies you can select range from 1333 ~ 3200 and Auto . DO NOT select Reserved from the list.

Table 5-5. Chipset Configuration Sub-menu (Continued)

Menu Option	Description
Max TOLUD	This feature allows you to specify the maximum value of TOLUD. Selecting the Dynamic assignment would adjust TOLUD automatically based upon the largest MMIO length of the installed graphic controller. Options include Dynamic and values from 1 GB ~ 3.5 GB.
Energy Performance Gain	This feature Enables or Disables the Energy Performance Gain.
Memory Scrambler	This feature Enables or Disables Memory Scrambler support.
Fast Boot	This feature Enables or Disables fast path through the MRC.
REFRESH_2X_MODE	Use this feature to select options for enabling or disabling refreshing 2X mode. Options include Disabled , 1-Enabled for WARM or HOT and 2-Enabled for HOT only.
Closed Loop Thermal Management	Use this feature to Enable or Disable Closed Loop Thermal Management for the system. When Enabled , the CLTM pcode algorithm will be used. Note: CLTM will precede OLTM.
▶GT-Power Management Control	Use this sub-menu provides options for GT-Power Management Control.
GT-Info	This static display shows GT Info.
RC6 (Render Standby)	This option allows you to Enable or Disable render standby support.

Table 5-6. SATA Configuration Sub-menu

Menu Option	Description
SATA Controller	This feature allows you to enable or disable the SATA controller. The options are Enabled and Disabled.
SATA Mode Selection	Use this setting to configure the SATA for either the RAID or AHCI options.
SATA Frozen	This setting enables/disables the Freeze Lock Security feature. The options are Enabled and Disabled .
SATA0 ~ SATA5 Hot Plug	This feature designates this port for hot plugging. Set this item to Enabled for hot-plugging support, which will allow the user to replace a SATA drive without shutting down the system. The options are Enabled and Disabled.
SATA0 ~ SATA5 Spin Up Device	If enabled for any of the ports Staggered Spin Up will be performed and only the drives which have this option enabled will spin up at boot. Otherwise (if disabled) all drives will spin up at boot. The options for this setting are Enabled and Disabled .
SATA0 ~ SATA5 SATA Device Type	This setting allows you to specify the selected port SATA device as being either a Hard Disk Drive or Solid State Drive.

Table 5-7. PCIe/PCI/PnP Configuration Sub-menu

Menu Option	Description
PCI Bus Driver Version	This displays the PCI Bus Driver Version for your system.
PCI Devices Common Settings:	

Table 5-7. PCIe/PCI/PnP Configuration Sub-menu (Continued)

Menu Option	Description
PCI PERR/SERR Support	Use this system to specify PCI PERR/SERR as enabled/disabled. The options are Enabled and Disabled .
Above 4G Decoding	This option Enables or Disables 64-bit capable devices to be decoded in Above 4G address space (only if the system supports 64-bit PCI decoding).
SR-IOV Support	If the system has SR-IOV capable PCIe Devices, this option enables or disables Single Root IO Virtualization Support. The options are Enabled and Disabled .
P1_M2_1 PCI-E3.0X4 Option ROM	This setting allows you to specify which firmware type to be loaded for the add-on card on this slot. Options include Disabled, Legacy and EFI.
P1_M2_2 PCI-E3.0X4 Option ROM	This setting allows you to specify which firmware type to be loaded for the add-on card on this slot. Options include Disabled, Legacy and EFI.
X710-BM2 OPROM	This setting allows you to specify which firmware type to be loaded for the add-on card on this slot. Options include Disabled, Legacy and EFI.
Onboard Video Option ROM	This setting selects the onboard video firmware type to be loaded. Options include Disabled, Legacy and EFI.
Network Stack	This setting enables/disables the UEFI Network Stack. The options for this setting are Enabled and Disabled .
IPv4 PXE Support	Use this setting to enable/disable IPv4 PXE boot support. If disabled, the IPv4 PXE boot option will not be created. Options include Enabled or Disabled.
IPv6 PXE Support	Use this setting to enable/disable IPv6 PXE boot support. If disabled, the IPv6 PXE boot option will not be created. Options include Enabled or Disabled.
PXE Boot Wait Time	This field specifies the wait time to press the ESC key to abort the PXE boot. Default is 0 .
Media Detect Count	This field specifies the number of times the presence of media will be checked. Default is 1 .

Table 5-8. USB Configuration Sub-menu

Menu Option	Description
USB Information	Static information for USB configuration is shown at the top of the screen. This includes USB Mobile Version, USB Controllers and USB Devices connected to the system.
Legacy USB Support	This option enables Legacy USB support for your system. Selecting the AUTO option disables legacy support if no USB devices are connected. Selecting the Disable option will keep USB devices available only for EFI applications. Selecting the Enable option allows Legacy USB support.
XHCI Hand-off	This option is a workaround for OS'es without XHCI hand-off support. The XHCI ownership change should be claimed by the XHCI driver.
Port 60/64 Emulation	This option enables the I/O port 60h/64h emulation support. This should be Enabled for the complete USB keyboard legacy support for non-USB aware OS'es.

Table 5-9. SuperIO Device Configuration Sub-menu

Menu Option	Description
Super IO Chip	This static display shows the name of the Super IO chip installed for your system.
► SOL Configuration	This sub-menu allows the user the configure SOL settings.
SOL Configuration	This option allows you to Enable or Disable the Serial Port (COM).
Change SOL Settings	Use this option to select an optimal setting for your Super IO device. Options include the following: <ul style="list-style-type: none"> • Auto • IO=2F8h; IRQ=3 • IO=3F8h; IRQ=3~12 • IO=2F8h; IRQ=3~12 • IO=3E8h; IRQ=3~12 • IO=2E8h; IRQ=3~12

Table 5-10. Intel Server Platform Services Sub-menu

Menu Option	Description
Intel Server Platform Services Configuration	This sub-menu displays static Intel Server Platform Services Configuration information.

Table 5-11. Serial Port Console Redirection Sub-menu

Menu Option	Description
COM1 Console Redirection	Select Enabled to enable console redirection support for the COM1 serial port. The options are Enabled and Disabled .
SOL Console Redirection	Select Enabled to enable console redirection support for SOL. The options are Enabled and Disabled.
► Console Redirection Settings (Both COM1 and SOL)	This feature allows the user to specify how the host computer will exchange data with the client computer, which is the remote computer used by the user.
Terminal Type	This feature allows the user to select the target terminal emulation type for Console Redirection. Select VT100 to use the ASCII Character set. Select VT100+ to add color and function key support. Select ANSI to use the Extended ASCII Character Set. Select VT-UTF8 to use UTF8 encoding to map Unicode characters into one or more bytes. The options are ANSI, VT100, VT100+ , and VT-UTF8.
Bits Per second	Use this feature to set the transmission speed for a serial port used in Console Redirection. Make sure that the same speed is used in the host computer and the client computer. A lower transmission speed may be required for long and busy lines. The options are 9600, 19200, 38400, 57600 and 115200 (bits per second).
Data Bits	Use this feature to set the data transmission size for Console Redirection. The options are 7 Bits and 8 Bits .

Table 5-11. Serial Port Console Redirection Sub-menu (Continued)

Menu Option	Description
Parity	A parity bit can be sent along with regular data bits to detect data transmission errors. Select Even if the parity bit is set to 0, and the number of 1's in data bits is even. Select Odd if the parity bit is set to 0, and the number of 1's in data bits is odd. Select None if you do not want to send a parity bit with your data bits in transmission. Select Mark to add a mark as a parity bit to be sent along with the data bits. Select Space to add a Space as a parity bit to be sent with your data bits. The options are None , Even, Odd, Mark and Space.
Stop Bits	A stop bit indicates the end of a serial data packet. Select 1 Stop Bit for standard serial data communication. Select 2 Stop Bits if slower devices are used. The options are 1 and 2.
Flow Control	Use this feature to set the flow control for Console Redirection to prevent data loss caused by buffer overflow. Send a "Stop" signal to stop sending data when the receiving buffer is full. Send a "Start" signal to start sending data when the receiving buffer is empty. The options are None and Hardware RTS/CTS.
VT-UTF8 Combo Key Support	Select Enabled to enable VT-UTF8 Combination Key support for ANSI/VT100 terminals. The options are Enabled and Disabled.
Recorder Mode	Select Enabled to capture the data displayed on a terminal and send it as text messages to a remote server. The options are Disabled and Enabled.
Resolution 100x31	Select Enabled for extended-terminal resolution support. The options are Disabled and Enabled .
Legacy OS Redirection Resolution	Use this feature to select the number of rows and columns used in Console Redirection for legacy OS support. The options are 80x24 and 80x25 .
Putty KeyPad	This feature selects the settings for Function Keys and KeyPad used for Putty, which is a terminal emulator designed for the Windows OS. The options are VT100 , LINUX, XTERMR6, SC0, ESCN, and VT400.
Redirection After BIOS Post	Use this feature to enable or disable legacy console redirection after BIOS POST. When set to Bootloader, legacy console redirection is disabled before booting the OS. When set to Always Enable, legacy console redirection remains enabled when booting the OS. The options are Always Enable and Bootloader.
EMS Console Redirection	Select Enabled to use a COM Port selected by the user for Console Redirection. The options are Enabled and Disabled .
►EMS Console Redirection Settings	This feature allows the user to specify how the host computer will exchange data with the client computer, which is the remote computer used by the user.
Out-of-Ban Management Port	The feature selects a serial port used by the Microsoft Windows Emergency Management Services (EMS) to communicate with a remote server. The options are COM1 and SOL for Console Redirection.

Table 5-11. Serial Port Console Redirection Sub-menu (Continued)

Menu Option	Description
Terminal Type	This feature allows the user to select the target terminal emulation type for Console Redirection. Select VT100 to use the ASCII character set. Select VT100+ to add color and function key support. Select ANSI to use the extended ASCII character set. Select VT-UTF8 to use UTF8 encoding to map Unicode characters into one or more bytes. The options are ANSI, VT100, VT100+, and VT-UTF8 .
Bits Per Second	This item sets the transmission speed for a serial port used in Console Redirection. Make sure that the same speed is used in the host computer and the client computer. A lower transmission speed may be required for long and busy lines. The options are 9600, 19200, 57600, and 115200 (bits per second).
Flow Control	This feature allows the user to set the flow control for Console Redirection to prevent data loss caused by buffer overflow. Send a "Stop" signal to stop sending data when the receiving buffer is full. Send a "Start" signal to start sending data when the receiving buffer is empty. The options are None , Hardware RTS/CTS, and Software Xon/Xoff.
Data Bits, Parity, Stop Bits	The status of each item above is static displayed.

Table 5-12. ACPI Settings Sub-menu

Menu Option	Description
High Precision Event Timer	Select Enabled to activate the High Performance Event Timer (HPET) that produces periodic interrupts at a much higher frequency than a Real-time Clock (RTC) does in synchronizing multimedia streams, providing smooth playback and reducing the dependency on other timestamp calculation devices, such as an x86 RDTSC Instruction embedded in the CPU. The High Performance Event Timer is used to replace the 8254 Programmable Interval Timer. The options are Enabled and Disabled.
WHEA Support	This feature Enables the Windows Hardware Error Architecture (WHEA) support for the Windows 2008 (or a later vision) operating system. The options are Enabled and Disabled.

Table 5-13. iSCSI Configuration Sub-menu

Menu Option	Description
iSCSI Initiator Name	This field specifies the worldwide unique name of the iSCSI initiator. Only an IQN format is accepted. Range is from 4 to 255.
Add an Attempt	Use this sub-menu for options to add an attempt.
Delete Attempt	Use this sub-menu for options to delete attempts.
Change Attempt Order	Use this sub-menu to change attempt order.

5-6 Event Logs Setup

Figure 5-4. Event Logs BIOS Setup Screen

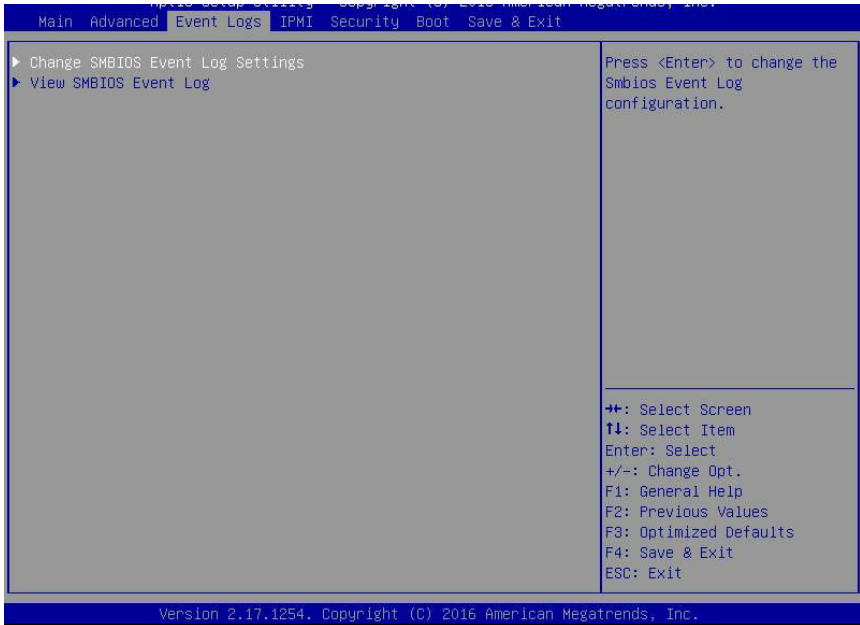

Table 5-14. Event Logs Menu

Menu Option	Description
► Change SMBIOS Event Log Settings	Use this sub-menu to change the SMBIOS Event Log configuration.
SMBIOS Event Log	Change this item to enable or disable all features of the SMBIOS Event Logging during system boot. The options are Enabled and Disabled.
Erase Event Log	If No is selected, data stored in the event log will not be erased. Select Yes, Next Reset, data in the event log will be erased upon next system reboot. Select Yes, Every Reset, data in the event log will be erased upon every system reboot. The options are No , Yes, Next reset, and Yes, Every reset.
When Log is Full	Select Erase Immediately for all messages to be automatically erased from the event log when the event log memory is full. The options are Do Nothing and Erase Immediately.
Log System Boot Event	This option toggles the System Boot Event logging to enabled or disabled. The options are Disabled and Enabled.
MECI	The Multiple Event Count Increment (MECI) counter counts the number of occurrences that a duplicate event must happen before the MECI counter is incremented. This is a numeric value. The default value is 1.

Table 5-14. Event Logs Menu (Continued)

Menu Option	Description
METW	The Multiple Event Time Window (METW) defines number of minutes must pass between duplicate log events before MECL is incremented. This is in minutes, from 0 to 99. The default value is 60 .
▶View SMBIOS Event Log	This sub-menu, when selected, displays a list of SMBIOS event logs.

5-7 IPMI Setup

Figure 5-5. IPMI BIOS Setup Screen



Choose **IPMI** from the BIOS Setup main menu with the arrow keys to bring up the IPMI SETUP menu. Options are displayed by highlighting the setting using the arrow keys and pressing <ENTER>. All IPMI BIOS settings are described in [Table 5-15](#) below.

Table 5-15. IPMI Menu

Menu Option	Description
BMC Firmware Revision	This indicates the BMC firmware revision used in your system.
IPMI Status	This indicates the status of the IPMI firmware installed in your system.
▶System Event Log	

Table 5-15. IPMI Menu (Continued)

Menu Option	Description
SEL Components	Use this setting to enable or disable all features of the System Event Logging during boot. The options are Enabled and Disabled.
Erasing Settings	
Erase SEL	Use this setting to erase SEL. Options are either Yes or No .
When SEL is Full	Use this option to choose the reactions to a full SEL. Options include Do Nothing or Erase Immediately.
►BMC Network Configuration	Use this sub-menu to information and controls to configure BMC network parameters.
Update IPMI LAN Configuration	This setting updates the IPMI LAN Configuration. BIOS will be set to the other settings specified and changed in this screen to the IPMI on the next boot. Options include No or Yes.
Configuration Address Source	This feature allows the user to select the source of the IP address for this computer. If Static is selected, you will need to know the IP address of this computer and enter it to the system manually in the field. If DHCP is selected, the BIOS will search for a DHCP (Dynamic Host Configuration Protocol) server in the network that is attached to and request the next available IP address for this computer. Options include Static or DHCP . The following items are assigned IP addresses automatically if DHCP is selected.
Station IP Address	This item displays the Station IP address for this computer. This should be in decimal and in dotted quad form (i.e., 192.168.10.253).
Subnet Mask	This item displays the sub-network that this computer belongs to. The value of each three-digit number separated by dots should not exceed 255.
Station MAC Address	This item displays the Station MAC address for this computer. Mac addresses are 6 two-digit hexadecimal numbers.
Gateway IP Address	This item displays the Gateway IP address for this computer. This should be in decimal and in dotted quad form (i.e., 192.168.10.253).
VLAN	Select to Enable or Disable the IPMI VLAN function.

5-8 Security

Figure 5-6. Security BIOS Setup Screen

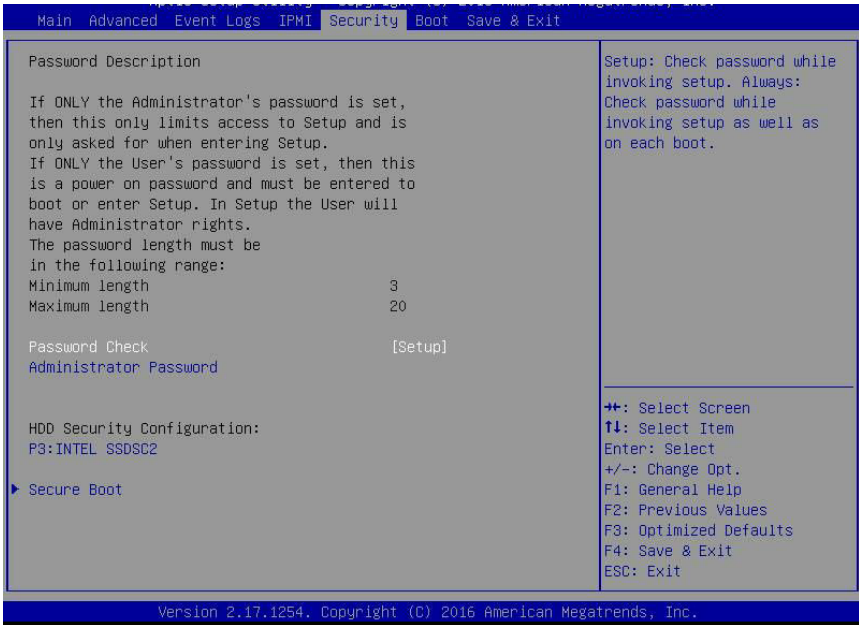

Choose **Security** from the BIOS Setup main menu with the arrow keys to bring up the SECURITY SETUP menu. Options are displayed by highlighting the setting using the arrow keys and pressing <ENTER>. All Security BIOS settings are described in [Table 5-16](#) below.

Table 5-16. Security Menu Options

Menu Option	Description
Password Check	This setting allows you to specify when the password is checked. Options specify when the setup should be done with Setup having the password checked when invoking setup, while Always checks the password while invoking setup as well as on each boot.
Administrator Password	This allows you to create an administrator password for the system.
CSM Support	This setting allows you to enable or disable CSM support. The options are Disabled and Enabled .
HDD Security Configuration	These options allow you to setup the HDD Security Configuration for each of the selected drives.
Secure Boot Sub-menu	This sub-menu allows you to customize Secure Boot settings.
Secure Boot Information	Static information for the System Mode, Secure Boot and Vendor Keys is provided at the top of this screen.
Secure Boot	This setting can be enabled if the system is running in a User Mode with an enrolled Platform Key (PK) and the CSM function is disabled. The options include Disabled and Enabled.
Secure Boot Mode	This setting is used for the Secure Boot Mode Selector. Custom mode enables you to change the Image Execution policy and manage Secure Boot Keys. Options include Standard and Custom.
CSM Support	Use this setting to Enable/Disable CSM Support.
▶Key Management	This sub-menu allows the user to configure the following Key Management settings.
▶Platform Key (PK)	This allows you to configure the settings of the Platform Keys.
▶Key Exchange Key	This allows you to configure the Key Exchange key. Options include Set New Key or Append Key.
▶Authorized Signatures	This allows you to configure the Authorized Signatures key. Options include Set New Key or Append Key.
▶Forbidden Signatures	This allows you to configure the Forbidden Signatures key. Options include Set New Key or Append Key.
▶Authorized TimeStamps	This allows you to configure the Authorized TimeStamps key. Options include Set New Key or Append Key.
▶OsRecover Signatures	This allows you to configure the OsRecover Signatures key. Options include Set New Key or Append Key.

5-9 Boot

Figure 5-7. Boot BIOS Setup Screen

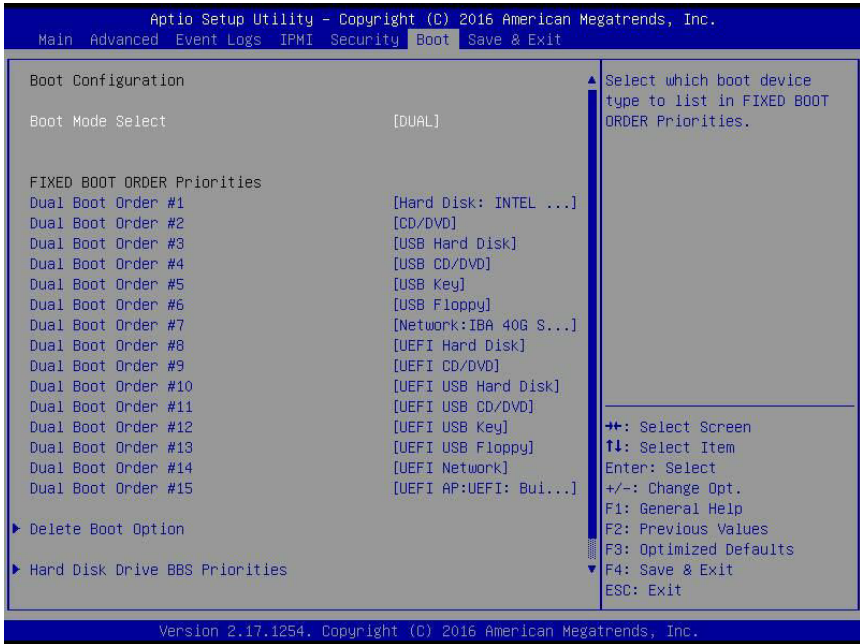

Choose **Boot** from the BIOS Setup Utility menu with the arrow keys to bring up the BOOT SETUP menu. Security setting options are displayed by highlighting the setting using the arrow keys and pressing <ENTER>. All Security BIOS settings are described in [Table 5-17](#) below.

Table 5-17. Boot Setup Menu Options

Menu Option	Description
Boot Mode Select	This selects which boot device type to list in the FIXED BOOT ORDER Priorities of this menu. Options include LEGACY, UEFI and DUAL .
Fixed Boot Order Priorities	Use these options to set what the boot priority order will be for various boot devices in your system.
▶Delete Boot Option	This sub-menu allows you to remove an EFI boot option form the boot order.
▶Hard Disk Drive BBS Priorities	This sub-menu allows you to specify the Boot Device Priority sequence from available Hard Disk Drives in your system.
▶Network Device BBS Priorities	This sub-menu allows you to set the order of the legacy devices in this group for setting the boot order.
▶UEFI Application Boot Priorities	This sub-menu allows you to specify the boot device priority sequence from available UEFI applications.

5-10 Save & Exit

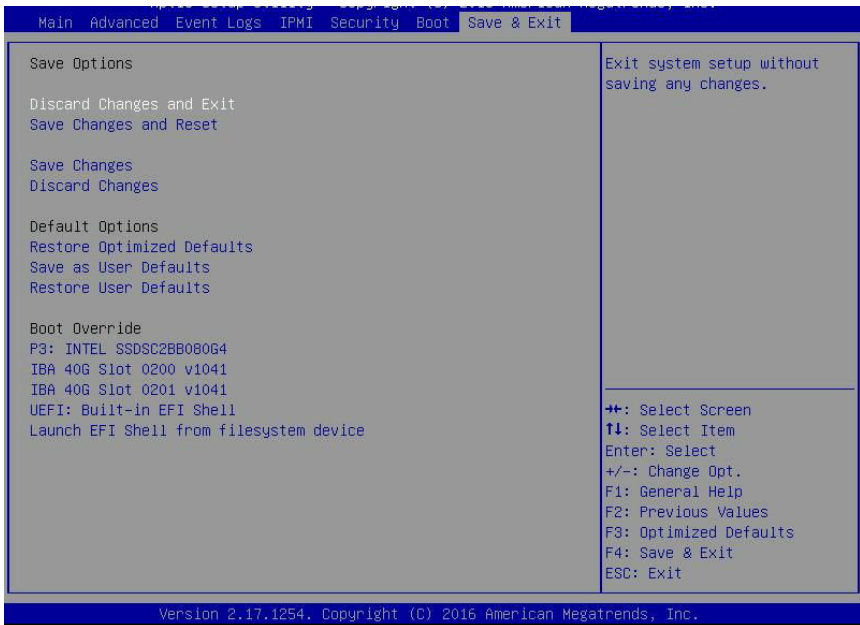
Figure 5-8. Save & Exit BIOS Setup Screen

Choose **SAVE & EXIT** from the BIOS Setup Utility menu with the arrow keys to display the **SAVE & EXIT SETUP** menu. All Exit BIOS settings are described in [Table 5-18](#) below.

Notes

Table 5-18. Exit Menu Options

Menu Option	Description
Discard Changes and Exit	Highlight this item and hit <ENTER> to exit the BIOS Setup utility without saving any changes you may have made. Any changes you have made to the BIOS Setup will not take effect upon system boot-up.
Save Changes and Reset	Highlight this item and hit <ENTER> to save any changes you made and to exit the BIOS Setup utility. The system will reboot and implement the changes you have made to the BIOS Setup.
Save Changes	Highlight this item and hit <ENTER> to save changes done so far to any of the setup options.
Discard Changes	Highlight this item and hit <ENTER> to discard (cancel) any changes you made. You will remain in the Setup utility.
Restore Optimized Defaults	Highlight this item and hit <ENTER> to load the default settings for all items in the BIOS Setup. These are the safest settings to use and are designed for maximum system performance, but may not work best for all computer applications.
Save as Users Defaults	Highlight this item and hit <ENTER> to save changes done so far as user defaults.
Restore User Defaults	Highlight this item and hit <ENTER> to restore the user defaults to all the setup options.
Boot Override	For each boot device you have the option of saving the configuration for it and exiting.

Appendix A

AMI UEFI BIOS POST Codes

A status code is a data value used to indicate progress during the boot phase. A subset of these status codes, known commonly as checkpoints, indicate common phases of the BIOS boot process.

Checkpoints are typically output to I/O port 80h, but Aptio 4.x core can be configured to send status codes to a variety of sources. Aptio 4.x core outputs checkpoints throughout the boot process to indicate the task the system is currently executing. Checkpoints are very useful in aiding software developers or technicians in debugging problems that occur during the pre-boot process.

A-1 Checkpoint Ranges

Table A-1. Checkpoint Ranges

Status Code Range	Description
0x01 – 0x0B	SEC execution
0x0C – 0x0F	SEC errors
0x10 – 0x2F	PEI execution up to and including memory detection
0x30 – 0x4F	PEI execution after memory detection
0x50 – 0x5F	PEI errors
0x60 – 0x8F	DXE execution up to BDS
0x90 – 0xCF	BDS execution
0xD0 – 0xDF	DXE errors
0xE0 – 0xE8	S3 Resume (PEI)
0xE9 – 0xEF	S3 Resume errors (PEI)
0xF0 – 0xF8	Recovery (PEI)
0xF9 – 0xFF	Recovery errors (PEI)

A-2 Standard Checkpoints

Table A-2. SEC Phase

Codes	Description
Status Code	
0x00	Not Used
Progress Codes	
0x01	Power on. Reset type detection (soft/hard).
0x02	AP initialization before microcode loading
0x03	North Bridge initialization before microcode loading
0x04	South Bridge initialization before microcode loading
0x05	OEM initialization before microcode loading
0x06	Microcode loading
0x07	AP initialization after microcode loading
0x08	North Bridge initialization after microcode loading
0x09	South Bridge initialization after microcode loading
0x0A	OEM initialization after microcode loading
0x0B	Cache initialization
0x0C – 0x0D	Reserved for future AMI SEC error codes
0x0E	Microcode not found
0x0F	Microcode not loaded

Table A-3. PEI Phase

Status Codes	Description
Progress Codes	
0x10	PEI Core is started
0x11	Pre-memory CPU initialization is started
0x12	Pre-memory CPU initialization (CPU module specific)
0x13	Pre-memory CPU initialization (CPU module specific)
0x14	Pre-memory CPU initialization (CPU module specific)
0x15	Pre-memory North Bridge initialization is started
0x16	Pre-Memory North Bridge initialization (North Bridge module specific)
0x17	Pre-Memory North Bridge initialization (North Bridge module specific)
0x18	Pre-Memory North Bridge initialization (North Bridge module specific)

Table A-3. PEI Phase

Status Codes	Description
0x19	Pre-memory South Bridge initialization is started
0x1A	Pre-memory South Bridge initialization (South Bridge module specific)
0x1B	Pre-memory South Bridge initialization (South Bridge module specific)
0x1C	Pre-memory South Bridge initialization (South Bridge module specific)
0x1D – 0x2A	OEM pre-memory initialization codes
0x2B	Memory initialization. Serial Presence Detect (SPD) data reading
0x2C	Memory initialization. Memory presence detection
0x2D	Memory initialization. Programming memory timing information
0x2E	Memory initialization. Configuring memory
0x2F	Memory initialization (other).
0x30	Reserved for ASL (see ASL Status Codes section below)
0x31	Memory Installed
0x32	CPU post-memory initialization is started
0x33	CPU post-memory initialization. Cache initialization
0x34	CPU post-memory initialization. Application Processor(s) (AP) initialization
0x35	CPU post-memory initialization. Boot Strap Processor (BSP) selection
0x36	CPU post-memory initialization. System Management Mode (SMM) initialization
0x37	Post-Memory North Bridge initialization is started
0x38	Post-Memory North Bridge initialization (North Bridge module specific)
0x39	Post-Memory North Bridge initialization (North Bridge module specific)
0x3A	Post-Memory North Bridge initialization (North Bridge module specific)
0x3B	Post-Memory South Bridge initialization is started
0x3C	Post-Memory South Bridge initialization (South Bridge module specific)
0x3D	Post-Memory South Bridge initialization (South Bridge module specific)
0x3E	Post-Memory South Bridge initialization (South Bridge module specific)
0x3F-0x4E	OEM post memory initialization codes
0x4F	DXE IPL is started
PEI Error Codes	
0x50	Memory initialization error. Invalid memory type or incompatible memory speed
0x51	Memory initialization error. SPD reading has failed
0x52	Memory initialization error. Invalid memory size or memory modules do not match.

Table A-3. PEI Phase

Status Codes	Description
0x53	Memory initialization error. No usable memory detected
0x54	Unspecified memory initialization error.
0x55	Memory not installed
0x56	Invalid CPU type or Speed
0x57	CPU mismatch
0x58	CPU self test failed or possible CPU cache error
0x59	CPU micro-code is not found or micro-code update is failed
0x5A	Internal CPU error
0x5B	reset PPI is not available
0x5C-0x5F	Reserved for future AML error codes
S3 Resume Progress Codes	
0xE0	S3 Resume is started (S3 Resume PPI is called by the DXE IPL)
0xE1	S3 Boot Script execution
0xE2	Video repost
0xE3	OS S3 wake vector call
0xE4-0xE7	Reserved for future AML progress codes
S3 Resume Error Codes	
0xE8	S3 Resume Failed
0xE9	S3 Resume PPI not Found
0xEA	S3 Resume Boot Script Error
0xEB	S3 OS Wake Error
0xEC-0xEF	Reserved for future AML error codes
Recovery Progress Codes	
0xF0	Recovery condition triggered by firmware (Auto recovery)
0xF1	Recovery condition triggered by user (Forced recovery)
0xF2	Recovery process started
0xF3	Recovery firmware image is found
0xF4	Recovery firmware image is loaded
0xF5-0xF7	Reserved for future AML progress codes
Recovery Error Codes	
0xF8	Recovery PPI is not available
0xF9	Recovery capsule is not found

Table A-3. PEI Phase

Status Codes	Description
0xFA	Invalid recovery capsule
0xFB – 0xFF	Reserved for future AMI error codes

Table A-4. PEI Beep Codes

# of Beeps	Description
1	Memory not Installed
1	Memory was installed twice (InstallPeiMemory routine in PEI Core called twice)
2	Recovery started
3	DXE IPL was not found
3	DXE Core Firmware Volume was not found
4	Recovery failed
4	S3 Resume failed
7	Reset PPI is not available

Table A-5. DXE Phase

Status Codes	Description
0x60	DXE Core is started
0x61	NVRAM initialization
0x62	Installation of the South Bridge Runtime Services
0x63	CPU DXE initialization is started
0x64	CPU DXE initialization (CPU module specific)
0x65	CPU DXE initialization (CPU module specific)
0x66	CPU DXE initialization (CPU module specific)
0x67	CPU DXE initialization (CPU module specific)
0x68	PCI host bridge initialization
0x69	North Bridge DXE initialization is started
0x6A	North Bridge DXE SMM initialization is started
0x6B	North Bridge DXE initialization (North Bridge module specific)
0x6C	North Bridge DXE initialization (North Bridge module specific)
0x6D	North Bridge DXE initialization (North Bridge module specific)
0x6E	North Bridge DXE initialization (North Bridge module specific)
0x6F	North Bridge DXE initialization (North Bridge module specific)

Table A-5. DXE Phase

Status Codes	Description
0x70	South Bridge DXE initialization is started
0x71	South Bridge DXE SMM initialization is started
0x72	South Bridge devices initialization
0x73	South Bridge DXE Initialization (South Bridge module specific)
0x74	South Bridge DXE Initialization (South Bridge module specific)
0x75	South Bridge DXE Initialization (South Bridge module specific)
0x76	South Bridge DXE Initialization (South Bridge module specific)
0x77	South Bridge DXE Initialization (South Bridge module specific)
0x78	ACPI module initialization
0x79	CSM initialization
0x7A – 0x7F	Reserved for future AMI DXE codes
0x80 – 0x8F	OEM DXE initialization codes
0x90	Boot Device Selection (BDS) phase is started
0x91	Driver connecting is started
0x92	PCI Bus initialization is started
0x93	PCI Bus Hot Plug Controller Initialization
0x94	PCI Bus Enumeration
0x95	PCI Bus Request Resources
0x96	PCI Bus Assign Resources
0x97	Console Output devices connect
0x98	Console input devices connect
0x99	Super IO Initialization
0x9A	USB initialization is started
0x9B	USB Reset
0x9C	USB Detect
0x9D	USB Enable
0x9E – 0x9F	Reserved for future AMI codes
0xA0	IDE initialization is started
0xA1	IDE Reset
0xA2	IDE Detect
0xA3	IDE Enable
0xA4	SCSI initialization is started

Table A-5. DXE Phase

Status Codes	Description
0xA5	SCSI Reset
0xA6	SCSI Detect
0xA7	SCSI Enable
0xA8	Setup Verifying Password
0xA9	Start of Setup
0xAA	Reserved for ASL (see ASL Status Codes section below)
0xAB	Setup Input Wait
0xAC	Reserved for ASL (see ASL Status Codes section below)
0xAD	Ready To Boot event
0xAE	Legacy Boot event
0xAF	Exit Boot Services event
0xB0	Runtime Set Virtual Address MAP Begin
0xB1	Runtime Set Virtual Address MAP End
0xB2	Legacy Option ROM Initialization
0xB3	System Reset
0xB4	USB hot plug
0xB5	PCI bus hot plug
0xB6	Clean-up of NVRAM
0xB7	Configuration Reset (reset of NVRAM settings)
0xB8 – 0xBF	Reserved for future AMI codes
0xC0 – 0xCF	OEM BDS initialization codes
DXE Error Codes	
0xD0	CPU initialization error
0xD1	North Bridge initialization error
0xD2	South Bridge initialization error
0xD3	Some of the Architectural Protocols are not available
0xD4	PCI resource allocation error. Out of Resources
0xD5	No Space for Legacy Option ROM
0xD6	No Console Output Devices are found
0xD7	No Console Input Devices are found
0xD8	Invalid password
0xD9	Error loading Boot Option (LoadImage returned error)

Table A-5. DXE Phase

Status Codes	Description
0xDA	Boot Option is failed (StartImage returned error)
0xDB	Flash update is failed
0xDC	Reset protocol is not available

Table A-6. DXE Beep Codes

# of Beeps	Description
1	Invalid password
4	Some of the Architectural Protocols are not available
5	No Console Output Devices are found
5	No Console Input Devices are found
6	Flash update is failed
7	Reset protocol is not available
8	Platform PCI resource requirements cannot be met

Table A-7. ACPI/ASL Checkpoints

Status Codes	Description
0x01	System is entering S1 sleep state
0x02	System is entering S2 sleep state
0x03	System is entering S3 sleep state
0x04	System is entering S4 sleep state
0x05	System is entering S5 sleep state
0x10	System is waking up from the S1 sleep state
0x20	System is waking up from the S2 sleep state
0x30	System is waking up from the S3 sleep state
0x40	System is waking up from the S4 sleep state
0xAC	System has transitioned into ACPI mode. Interrupt controller is in PIC mode.
0xAA	System has transitioned into ACPI mode. Interrupt controller is in APIC mode.

A-3 OEM-Reserved Checkpoint Ranges

Table A-8. OEM-Reserved Checkpoint Ranges

Status Codes	Description
0x05	OEM SEC initialization before microcode loading
0x0A	OEM SEC initialization after microcode loading
0x1D – 0x2A	OEM pre-memory initialization codes
0x3F – 0x4E	OEM PEI post memory initialization codes
0x80 – 0x8F	OEM DXE initialization codes
0xC0 – 0xCF	OEM BDS initialization codes

Appendix B

Specifications and Compliance

Operating Environment

Operating Temperature: 10° to 35° C (50° to 95° F)

Non-operating Temperature: -40° to 70° C (-40° to 158° F)

Operating Relative Humidity: 8% to 90% (non-condensing)

Non-operating Relative Humidity: 5% to 95% (non-condensing)

Regulatory Compliance

FCC, ICES, CE, VCCI, RCM, NRTL, CB

Applied Directives, Standards

EMC/EMI: 2014/30/EU (EMC Directive)

FCC Part 15

ICES-003

VCCI 32-1

AS/NZS CISPR 32

EN55032

EN55035

CISPR 24

EN 61000-3-2

EN 61000-3-3

EN 61000-4-2

EN 61000-4-3

EN 61000-4-4

EN 61000-4-5

EN 61000-4-6

EN 61000-4-8

EN 61000-4-11

Green Environment:

2011/65/EU (RoHS Directive)

EC 1907/2006 (REACH)

2012/19/EU (WEEE Directive)

Product Safety: 2014/35/EU (LVD Directive)

UL/CSA 60950-1, 62368-1 (USA and Canada)

IEC/EN 60950-1, 62368-1

Perchlorate Warnings

California Best Management Practices Regulations for Perchlorate Materials: This Perchlorate warning applies only to products containing CR (Manganese Dioxide) Lithium coin cells. "Perchlorate Material-special handling may apply. See www.dtsc.ca.gov/hazardouswaste/perchlorate"

General Data Center Environmental Specifications

Particulate contamination specifications

Air filtration: Data centers must be kept clean to Class 8 of ISO 14644-1 (ISO 2015). The air entering the data center should be filtered with a MERV 11 filter or better. The air within the data center should be continuously filtered with a MERV 8 filter or better.

Conductive dust: Air should be free fo conductive dust, zinc whiskers, or other conductive particles.

Corrosive dust: Air should be free of corrosive dust.

Gaseous* contamination specifications

Copper coupon corrosion rate: <300 Å/month per class G1 as defined by ANSI. ISA71.04-2013, reference by ASHRAE TC 9.9

Silver coupon corrosion rate: <200 Å/month per class G1 as defined by ANSI. ISA71.04-2013, reference by ASHRAE TC 9.9

*If testing with silver or copper coupons results in values less that 200 Å/month or 300 Å/month, respectively, then operating up to 70% relative humidity (RH) is acceptable. If the testing shows corrosion levels exceed these limits, then catalyst-type pollutants are probably present and RH should be driven to 50% or lower.

Disclaimer

The products sold by Supermicro are not intended for and will not be used in life support systems, medical equipment, nuclear facilities or systems, aircraft, aircraft devices, aircraft/emergency communication devices or other critical systems whose failure to perform be reasonably expected to result in significant injury or loss of life or catastrophic property damage. Accordingly, Supermicro disclaims any and all liability, and should buyer use or sell such products for use in such ultra-hazardous applications, it does so entirely at its own risk. Furthermore, buyer agrees to fully indemnify, defend and hold Supermicro harmless for and against any and all claims, demands, actions, litigation, and proceedings of any kind arising out of or related to such ultra-hazardous use or sale.