

SUPER  [®]

SUPER  [®] X8SIT-F

USER'S MANUAL

Revision 1.0

The information in this User's Manual has been carefully reviewed and is believed to be accurate. The vendor assumes no responsibility for any inaccuracies that may be contained in this document, makes no commitment to update or to keep current the information in this manual, or to notify any person or organization of the updates. **Please Note: For the most up-to-date version of this manual, please see our web site at www.supermicro.com.**

Super Micro Computer, Inc. ("Supermicro") reserves the right to make changes to the product described in this manual at any time and without notice. This product, including software, if any, and documentation may not, in whole or in part, be copied, photocopied, reproduced, translated or reduced to any medium or machine without prior written consent.

IN NO EVENT WILL SUPER MICRO COMPUTER, INC. BE LIABLE FOR DIRECT, INDIRECT, SPECIAL, INCIDENTAL, SPECULATIVE OR CONSEQUENTIAL DAMAGES ARISING FROM THE USE OR INABILITY TO USE THIS PRODUCT OR DOCUMENTATION, EVEN IF ADVISED OF THE POSSIBILITY OF SUCH DAMAGES. IN PARTICULAR, SUPER MICRO COMPUTER, INC. SHALL NOT HAVE LIABILITY FOR ANY HARDWARE, SOFTWARE, OR DATA STORED OR USED WITH THE PRODUCT, INCLUDING THE COSTS OF REPAIRING, REPLACING, INTEGRATING, INSTALLING OR RECOVERING SUCH HARDWARE, SOFTWARE, OR DATA.

Any disputes arising between manufacturer and customer shall be governed by the laws of Santa Clara County in the State of California, USA. The State of California, County of Santa Clara shall be the exclusive venue for the resolution of any such disputes. Supermicro's total liability for all claims will not exceed the price paid for the hardware product.

FCC Statement: This equipment has been tested and found to comply with the limits for a Class A digital device pursuant to Part 15 of the FCC Rules. These limits are designed to provide reasonable protection against harmful interference when the equipment is operated in a commercial environment. This equipment generates, uses, and can radiate radio frequency energy and, if not installed and used in accordance with the manufacturer's instruction manual, may cause harmful interference with radio communications. Operation of this equipment in a residential area is likely to cause harmful interference, in which case you will be required to correct the interference at your own expense.

California Best Management Practices Regulations for Perchlorate Materials: This Perchlorate warning applies only to products containing CR (Manganese Dioxide) Lithium coin cells. "Perchlorate Material-special handling may apply. See www.dtsc.ca.gov/hazardouswaste/perchlorate".

WARNING: Handling of lead solder materials used in this product may expose you to lead, a chemical known to the State of California to cause birth defects and other reproductive harm.

Manual Revision 1.0

Release Date: March 8, 2010

Unless you request and receive written permission from Super Micro Computer, Inc., you may not copy any part of this document.

Information in this document is subject to change without notice. Other products and companies referred to herein are trademarks or registered trademarks of their respective companies or mark holders.

Copyright © 2010 by Super Micro Computer, Inc.
All rights reserved.

Printed in the United States of America

Preface

This manual is written for system integrators, PC technicians and knowledgeable PC users. It provides information for the installation and use of the **SUPER** X8SIT-F motherboard.

About This Motherboard

The **SUPER** X8SIT-F supports the Intel® Xeon® and L3400 series, Core™ i3 and Pentium® G6950 processors (LGA1156 socket). With the Intel 3420 chipset built-in, the X8SIT-F offers substantial enhancements in price/system performance ratio in a high-efficient, space optimal twin solution design. Please refer to our web site (<http://www.supermicro.com/products/>) for updates on supported processors. This product is intended to be installed and serviced by professional technicians.

Manual Organization

Chapter 1 provides quick installation instructions.

Chapter 2 describes the features, specifications and performance of the motherboard and provides detailed information about the chipset.

Chapter 3 provides hardware installation instructions. Read this chapter when installing the processor, memory modules and other hardware components into the system. If you encounter any problems, see **Chapter 4**, which describes troubleshooting procedures for video, memory and system setup stored in the CMOS.

Chapter 5 includes an introduction to the BIOS and provides detailed information on running the CMOS Setup utility.

Appendix A provides BIOS Error Beep Codes.

Appendix B lists Other Software Program Installation Instructions.

Conventions Used in the Manual:

Special attention should be given to the following symbols for proper installation and to prevent damage done to the components or injury to yourself:



Danger/Caution: Instructions to be strictly followed to prevent catastrophic system failure or to avoid bodily injury



Warning: Important information given to ensure proper system installation or to prevent damage to the components



Note: Additional Information given to differentiate various models or provides information for correct system setup.

Contacting Supermicro

Headquarters

Address: Super Micro Computer, Inc.
980 Rock Ave.
San Jose, CA 95131 U.S.A.

Tel: +1 (408) 503-8000

Fax: +1 (408) 503-8008

Email: marketing@supermicro.com (General Information)
support@supermicro.com (Technical Support)

Web Site: www.supermicro.com

Europe

Address: Super Micro Computer B.V.
Het Sterrenbeeld 28, 5215 ML
's-Hertogenbosch, The Netherlands

Tel: +31 (0) 73-6400390

Fax: +31 (0) 73-6416525

Email: sales@supermicro.nl (General Information)
support@supermicro.nl (Technical Support)
rma@supermicro.nl (Customer Support)

Asia-Pacific

Address: Super Micro Computer, Inc.
4F, No. 232-1, Liancheng Rd.
Chung-Ho 235, Taipei County
Taiwan, R.O.C.

Tel: +886-(2) 8226-3990

Fax: +886-(2) 8226-3991

Web Site: www.supermicro.com.tw

Technical Support:

Email: support@supermicro.com.tw

Tel: 886-2-8228-1366, ext.132 or 139

Table of Contents

Preface

About This Motherboard.....	3
Manual Organization	3
Conventions Used in the Manual:.....	3
Contacting Supermicro.....	4

Chapter 1 Introduction

1-1 Overview	1-1
Checklist.....	1-1
Motherboard Features.....	1-7
1-2 Chipset Overview	1-10
Intel 3420 Chipset Features.....	1-10
1-3 PC Health Monitoring.....	1-11
Recovery from AC Power Loss.....	1-11
Onboard Voltage Monitoring	1-11
Fan Status Monitor with Software.....	1-11
CPU Overheat LED and Control	1-11
1-4 Power Configuration Settings.....	1-11
Slow Blinking LED for Suspend-State Indicator	1-12
BIOS Support for USB Keyboard.....	1-12
Main Switch Override Mechanism	1-12
1-5 Power Supply	1-12
1-6 Super I/O.....	1-12
1-7 Overview of the Nuvoton BMC Controller.....	1-13

Chapter 2 Installation

2-1 Electro-Static Sensitive Devices	2-1
Precautions	2-1
Unpacking	2-1
2-2 Processor and Heatsink Installation.....	2-2
Installing the LGA1156 Processor.....	2-2
Installing a Passive CPU Heatsink	2-5
Removing the Heatsink.....	2-6
2-3 System Memory	2-7
How to Install DIMMs.....	2-7
Memory Support.....	2-7
Memory Population Guidelines	2-8
Installing and Removing DIMMs	2-10

	Tools Needed	2-12
	Location of Mounting Holes	2-12
2-4	Motherboard Installation.....	2-12
	Installation Instructions.....	2-13
2-5	Connectors/IO Ports.....	2-14
	Back Panel Connectors and IO Ports.....	2-14
	Universal Serial Bus (USB).....	2-15
	Ethernet Ports	2-16
	Serial Port.....	2-17
	Video Connector.....	2-18
	Front Control Panel.....	2-19
	Front Control Panel Pin Definitions.....	2-20
	Power LED	2-20
	HDD LED.....	2-20
	Power Fail LED	2-20
	NIC1/NIC2 (LAN1/LAN2).....	2-21
	Overheat (OH)/Fan Fail/Front UID LED.....	2-21
	Reset Button	2-22
	Power Button	2-22
2-6	Connecting Cables.....	2-23
	20-pin Proprietary Power Connectors.....	2-23
	Fan Headers.....	2-24
	Chassis Intrusion	2-24
	Internal Speaker/Buzzer.....	2-25
	External Speaker.....	2-25
	Onboard Power LED	2-26
	Power Supply I ² C Connector.....	2-26
	T-SGPIO 0/1 Headers.....	2-27
	Compact Flash/DOM PWR Connector.....	2-27
	Trusted Platform Module Header	2-28
	Unit ID Switch.....	2-29
	IPMB.....	2-29
2-7	Jumper Settings	2-30
	Explanation of Jumpers	2-30
	LAN Port Enable/Disable	2-30
	CMOS Clear.....	2-31
	PCI Slot SMB Enable.....	2-31
	USB Wake-Up	2-32
	BMC Jumper (JPB)	2-32

- VGA Enable 2-33
- TPM Support Enable 2-33
- Hot Swap Enable/Disable (JPEN1)..... 2-33
- 2-8 Onboard Indicators..... 2-34
 - LAN LEDs 2-34
 - IPMI Dedicated LAN..... 2-34
 - Onboard Standby Power LED 2-35
 - IPMI Heartbeat LED 2-35
 - Rear UID LED 2-35
 - Memory Status LED 2-35
- 2-9 SATA Drive Connections 2-36
 - SATA Connections 2-36

Chapter 3 Troubleshooting

- 3-1 Troubleshooting Procedures 3-1
 - Before Power On 3-1
 - No Power 3-1
 - No Video 3-1
 - Memory Errors 3-2
 - Lost System Setup Configuration 3-2
- 3-2 Technical Support Procedures 3-2
- 3-3 Frequently Asked Questions 3-3
- 3-4 Battery Removal and Installation 3-6
 - Battery Removal..... 3-6
 - Battery Installation..... 3-6
- 3-5 Returning Merchandise for Service..... 3-7

Chapter 4 BIOS

- 4-1 Introduction..... 4-1
 - Starting BIOS Setup Utility..... 4-1
 - How To Change the Configuration Data 4-1
 - How to Start the Setup Utility 4-2
- 4-2 Main Setup 4-2
- 4-3 Advanced Setup Configurations..... 4-4
- 4-4 Security Settings 4-20
- 4-5 Boot Settings 4-21
- 4-6 Exit Options..... 4-22

Appendix A POST Error Beep Codes

Recoverable POST Error Beep CodesA-1

Appendix B Software Installation Instructions

B-1 Installing Drivers.....B-1

B-2 Configuring Supero Doctor IIIB-2

Appendix C - BIOS Recovery

C-1 Recovery Process from a USB Device/Drive (Recommended Method).....C-1

C-2 Recovery Process from an IDE/SATA ATAPI Disc DriveC-2

Chapter 1

Introduction

1-1 Overview

Checklist

Congratulations on purchasing your computer motherboard from an acknowledged leader in the industry. Supermicro boards are designed with the utmost attention to detail to provide you with the highest standards in quality and performance.

Please check that the following items have all been included with your motherboard. If anything listed here is damaged or missing, contact your retailer.

The following items are included in the retail box.

- One (1) Supermicro Mainboard
- Six (6) SATA cables (CBL-0044L)
- One (1) Supermicro CD containing drivers and utilities (CDR-X8-UP)
- One (1) User's Manual (MNL-1182)

SUPER Motherboard Image



 **Note:** All graphics shown in this manual were based upon the latest PCB Revision available at the time of publishing of the manual. The motherboard you've received may or may not look exactly the same as the graphics shown in this manual.

Motherboard Layout

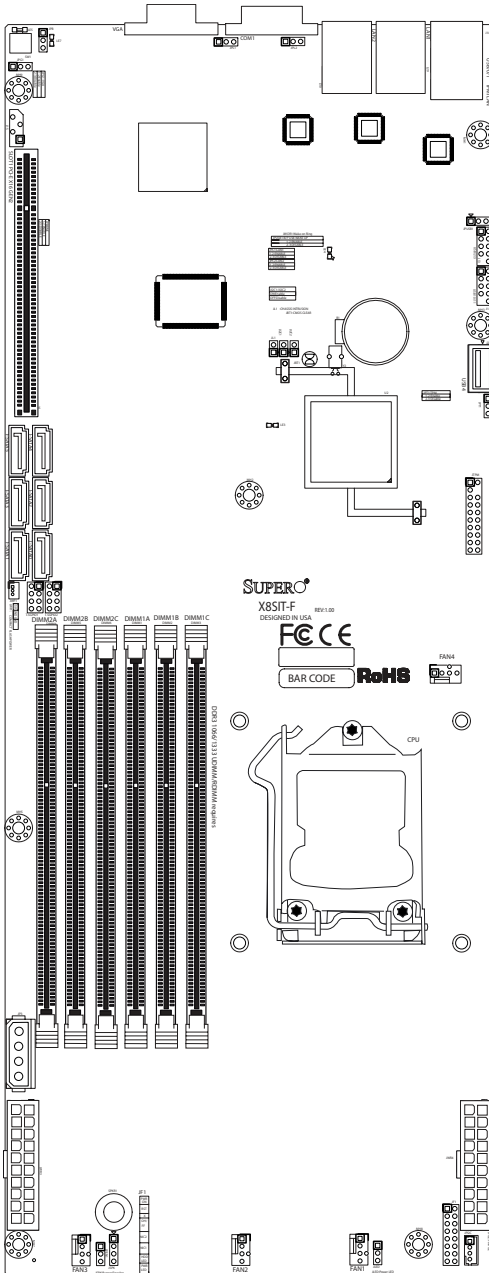

Important Notes to the User

- See Chapter 3 for detailed information on jumpers, I/O ports and JF1 front panel connections.
- "■" indicates the location of "Pin 1".
- Jumpers not indicated are for testing only.
- When LE4 (Onboard Power LED Indicator) is on, stand-by power is on. Unplug the power cable before installing or removing any components.
- Some motherboard illustrations in this manual have been rotated -90 degrees to provide better detail.

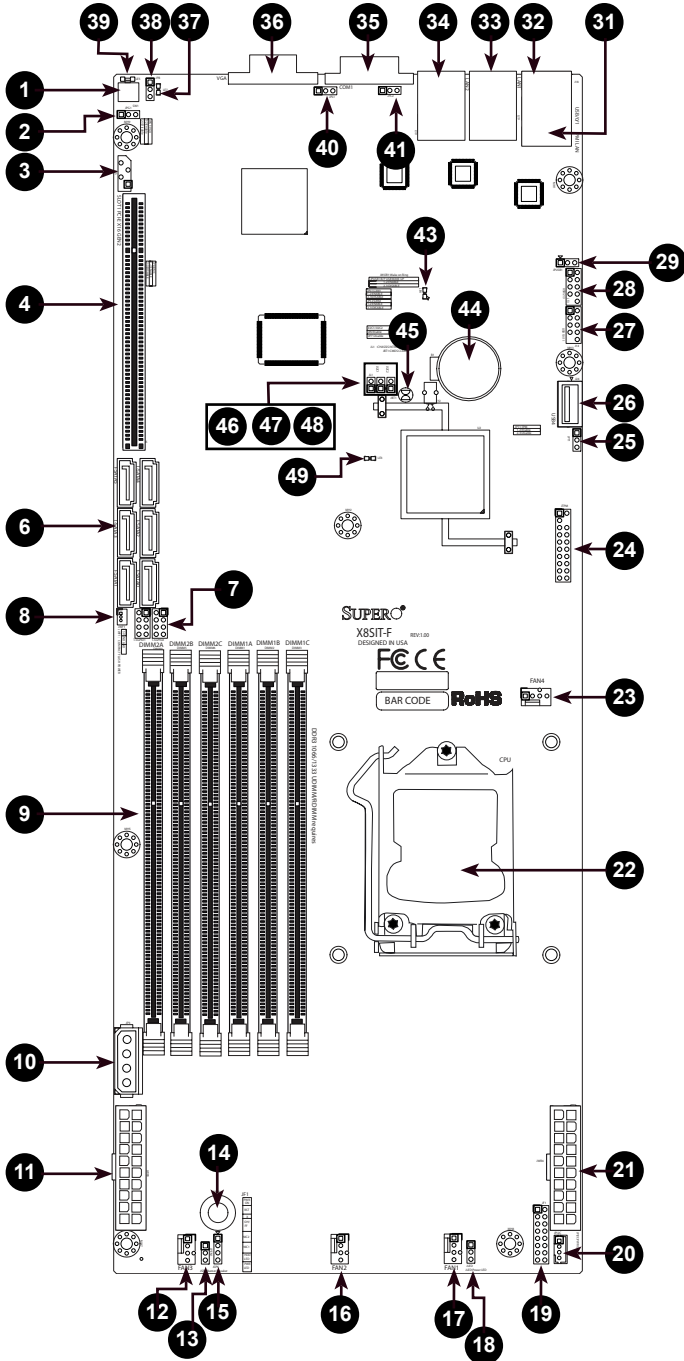

X8SIT-F Quick Reference

Switches, Headers & Connectors		
Number	Connector	Description
1	SW1	Unit ID Switch
3	J5	System Management Bus (SMB) Header for IPMI 2.0
4	Slot 1	PCI-E X16 GEN2 Slot (Slot 1)
6	SATA0~5	SATA Ports 0 through 5
7	T-SGPIO-0/1	Serial General Purpose I/O Headers (for SATA)
8	JWF1	Compact Flash/DOM Power Connector
9	DIMM Slots 1~6	Memory Slots (DDR3 1066/1333 UDIMM/RDIMM)
10	JP3	4-Pin Auxilliary Power for Peripheral Devices
11,21	JWR3,JWR4	20-pin main proprietary power connectors
12,16,17,23	FAN3,2,1,4	System Fan Power Connectors
14	SPKR1	Internal Speaker/Buzzer
15	SPK	External Speaker Header (Short pins 3-4 to use Onboard)
18	JLED	Power LED Indicator Header
19	JF1	Front Panel Control Header
20	JPI2C	PWR supply (I ² C) System Management Bus
22	CPU	LGA 1156 CPU Socket
24	JTPM	TPM Header
26	USB4	Type A Internal USB Port
27	USB10/11	USB10/11 Front Panel USB Header
28	USB2/3	USB2/3 Front Panel USB Header
31	IPMI LAN	Back Panel IPMI 2.0 LAN Port
32	USB0/1	Back Panel USB Ports (USB0/1)
33,34	LAN1/LAN2	Back Panel LAN Ports (RJ45)
35	COM1	Back Panel COM1 Port
36	VGA	Back Panel VGA Port
44	B1	Onboard Battery
46	JL1	Chassis Intrusion Header

LED Indicators				
Number	LED	Description	Color/State	Status
37	LE7	IPMI Heartbeat LED	Yellow: Blinking	IPMI: Normal
39	LE5	Unit ID LED	Blue: Solid On	UID On
43	LE4	Standby Power LED	Green: Solid On	Power On
49	LE3	Memory Status	Yellow: Blinking	Error

Jumpers			
Number	Jumper	Description	Default
2	JPG	Onboard VGA Enable	Pins 1-2 (Enabled)
13	JPEN1	Hot Swap Enable/Disable	Pins 1-2 (Enabled)
25	JPT1	TPM Enable	Pins 1-2 (Enabled)
29	JPUSB1	USB Wake-up	Pins 1-2 (Enabled)
38	JPB	BMC Jumper	Pins 1-2 (Enabled)
40,41	JPL1/JPL2	LAN1//LAN2 Enable	Pins 1-2 (Enabled)
45	JBT1	CMOS Clear	See Chapter 3
47,48	J1 ² C1/J1 ² C2	SMB to PCI Slots	See Chapter 3

Motherboard Features

CPU	Single Intel® Xeon® 3400 and L3400 Series, Core™ i3 and Pentium® G6950 processors (LGA1156 socket)	
Memory	Six (6) 240-pin, DDR3 ECC SDRAM DIMM sockets with support for up to 16GB of UDIMM or up to 32GB of RDIMM 1333/1066/800 MHz memory only.	
	Supports dual-channel memory architecture	
	DIMM sizes	
	UDIMM	512MB, 1GB, 2GB, and 4GB
	RDIMM	512MB, 1GB, 2GB, 4GB, and 8GB
Chipset	Intel® 3420 Chipset	
Expansion Slots	One (1) PCI-E 2.0 x16 slot (Graphics or I/O)	
Integrated Graphics	Matrox® G200eW with 16MB of memory	
Network Connections	Two Intel 82574L Gigabit (10/100/1000 Mb/s) Ethernet Controllers.	
	Two (2) RJ-45 Rear IO Panel Connectors with Link and Activity LEDs	
	Single Realtek RTL8201N PHY to support IPMI 2.0	
I/O Devices	SATA Connections	
	SATA Ports	Six (6)
	Integrated IPMI 2.0	
	IPMI 2.0 supported by the WPCM450 Server BMC	
	USB Devices	
	Two (2) USB ports on the rear IO panel	
	Four (4) USB devices via Two (2) USB header connectors for front access	
	One (1) Type A internal connector	
	Serial (COM) Ports	
	One (1) Fast UART 16550 Connection (9-pin RS-232 port on the back panel)	
	Super I/O	
	Winbond Super I/O W83627DHG UBE	
	BIOS	32 Mb SPI AMI BIOS® SM Flash BIOS
DMI 2.3, PCI 2.3, ACPI 1.0/2.0/3.0, USB Keyboard and SMBIOS 2.5		

Power Configuration	ACPI/ACPM Power Management
	Main switch override mechanism
	Keyboard Wake-up from Soft-Off
	Internal/External modem ring-on
	Power-on mode for AC power recovery
PC Health Monitoring	CPU Monitoring
	Onboard voltage monitors for CPU core, +3.3V, +5V, +/-12V, +3.3V Stdbby, 5V Stdbby, VBAT, Memory, Chipset
	CPU 4-Phase switching voltage regulator
	CPU/System overheat LED and control
	CPU Thermal Trip support
	Thermal Monitor 2 (TM2) support
	Fan Control
	Fan status monitoring with firmware 4-pin (Pulse Width Modulation) fan speed control
	Low noise fan speed control
	System Management
System resource alert via Supero Doctor III	
SuperoDoctor III, Watch Dog, NMI	
Chassis Intrusion Header and Detection	
CD Utilities	BIOS flash upgrade utility
	Drivers and software for Intel® 3420 chipset utilities
Other	ROHS 6/6 (Full Compliance, Lead Free)
	UID LED Support
Dimensions	Proprietary form factor, 6.5" x 16.4"



Note: For IPMI Configuration Instructions, please refer to the Embedded IPMI Configuration User's Guide available @ <http://www.supermicro.com/support/manuals/>.

BLOCK DIAGRAM

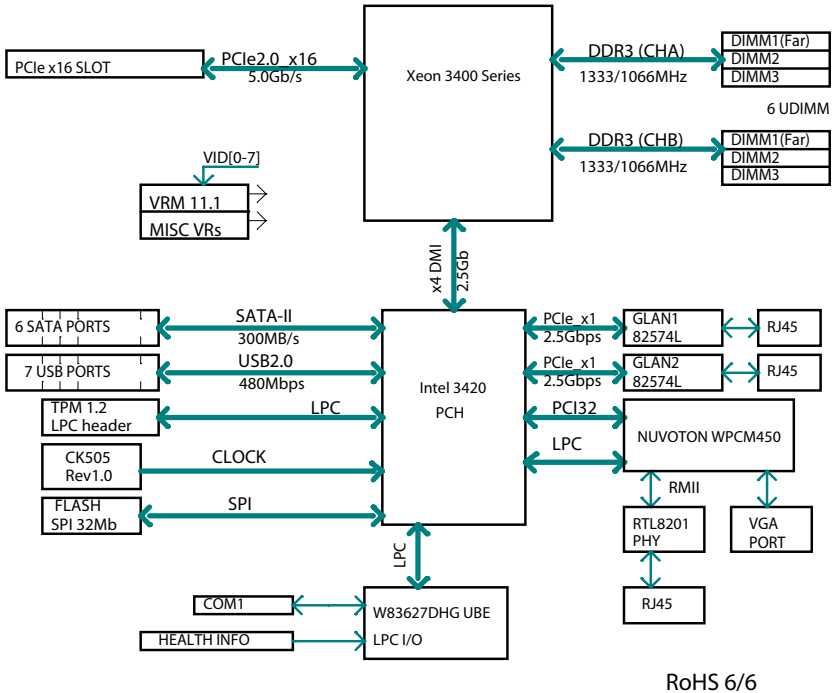

X8SIT-F System Block Diagram



Note: This is a general block diagram and may not exactly represent the features on your motherboard. See the Motherboard Features pages for the actual specifications of each motherboard.

1-2 Chipset Overview

The X8SIT-F supports the Intel® Xeon® 3400 and L3400 Series, Core™ i3 and Pentium® G6950 processors (LGA1156 socket). Built upon the functionality and the capability of the single-chip Intel 3420 chipset, the X8SIT-F motherboard provides the performance and feature set required for single-processor-based systems with configuration options optimized for cost-effective server platforms.

The Intel 3420 chipset features a high-speed Direct Media Interface (DMI) for chip-to-chip true isochronous communication with the processor. This feature allows the X8SIT-F to achieve up to 10 Gb/s of software-transparent data transfer in each direction, achieving better performance than comparable systems. The X8SIT-F also features a high-efficient VRM design (90%), ECC Error Reporting, Intruder Detect and TCO timer which will enable the system to recover from a software/hardware lock.

Intel 3420 Chipset Features

- Direct Media Interface (up to 10 Gb/s transfer, Full Duplex)
- Intel® Matrix Storage Technology and Intel Rapid Storage Technology
- Intel I/O Virtualization (VT-d) Support
- Intel Trusted Execution Technology Support
- PCI Express 2.0 Interface (up to 2.5 GT/s)
- SATA Controller (up to 3Gb/s)
- Advanced Host Controller Interface (AHCI)

1-3 PC Health Monitoring

This section describes the PC health monitoring features of the X8SIT-F. These features are supported by an onboard System Hardware Monitor chip.

Recovery from AC Power Loss

BIOS provides a setting for you to determine how the system will respond when AC power is lost and then restored to the system. You can choose for the system to remain powered off (in which case you must hit the power switch to turn it back on) or for it to automatically return to a power on state. See the Power Lost Control setting in the BIOS chapter of this manual to change this setting. The default setting is **Last State**.

Onboard Voltage Monitoring

The onboard voltage monitor will scan the following voltages continuously: CPU core, +3.3V, +5V, +12V, +3.3V Stdbby, 5V Stdbby, VBAT, Memory. Once a voltage becomes unstable, it will give a warning or send an error message to the screen. Users can adjust the voltage thresholds to define the sensitivity of the voltage monitor by using SD III.

Fan Status Monitor with Software

PC health monitoring can check the RPM status of the cooling fans via Supero Doctor III.

CPU Overheat LED and Control

This feature is available when the user enables the CPU overheat warning feature in the BIOS. This allows the user to define an overheat temperature. When this temperature reaches this pre-defined overheat threshold, the CPU thermal trip feature will be activated and send a signal to the buzzer and, at the same time, the CPU speed will be decreased.

1-4 Power Configuration Settings

This section describes the features of your motherboard that deal with power and power settings.

Slow Blinking LED for Suspend-State Indicator

When the CPU goes into a suspend state, the chassis power LED will start blinking to indicate that the CPU is in the suspend mode. When the user presses any key, the CPU will wake-up and the LED indicator will automatically stop blinking and remain on.

BIOS Support for USB Keyboard

If the USB keyboard is the only keyboard in the system, it will function like a normal keyboard during system boot-up.

Main Switch Override Mechanism

When an ATX power supply is used, the power button can function as a system suspend button. When the user presses the power button, the system will enter a SoftOff state. The monitor will be suspended and the hard drive will spin down. Press the power button again to wake-up the whole system. During the SoftOff state, the ATX power supply provides power the system to keep the required circuitry "alive". In case the system malfunctions and you want to turn off the power, just press and hold the power button for 4 seconds. The power will turn off and no power will be provided to the motherboard.

1-5 Power Supply

As with all computer products, a stable power source is necessary for proper and reliable operation. It is even more important for processors that have high CPU clock rates.

The X8SIT-F can only accommodate Supermicro proprietary power supply. Please refer to Section 3-6 for more information.

1-6 Super I/O

The X8SIT-F provides one high-speed, 16550-compatible serial communication ports (UARTs). This UART includes a 16-byte send/receive FIFO, a programmable baud rate generator, complete modem control capability and a processor interrupt system. Both UARTs provide legacy speed with baud rate of up to 115.2 Kbps as well as an advanced speed with baud rates of 250 K, 500 K, or 1 Mb/s, which support higher speed modems.

The Super I/O provides functions that comply with ACPI (Advanced Configuration and Power Interface), which includes support of legacy and ACPI power management through a SMI or SCI function pin. It also features auto power management to reduce power consumption.

1-7 Overview of the Nuvoton BMC Controller

The NuvotonSM WPCM450 is a combined Baseboard Management Controller and 2D/VGA-compatible Graphics Core with PCI interface, Virtual Media and Keyboard, and a Keyboard/Video/Mouse Redirection (KVMR) module.

The WPCM450 interfaces with the host system via a PCI interface to communicate with the Graphics core. It supports USB 2.0 and 1.1 for remote keyboard/mouse/virtual media emulation. It also provides an LPC interface to control Super I/O functions and connects to the network via an external Ethernet PHY module or shared NCSI connections.

The Nuvoton BMC communicates with onboard components via six SMBus interfaces, fan control, Platform Environment Control Interface (PECI) buses, and General Purpose I/O .

It also includes the following features:

- One X-Bus parallel interface for expansion I/O connections
- Three ADC inputs, Analog and Digital Video outputs
- Two serial for boundary scan and debug

There are two different versions of the Nuvoton BMC chip used on Supermicro X8Six series motherboards, the Nuvoton WPCM150 (Manufacturer P/N WPC-M150GA0BX5) and Nuvoton WPCM450 (Manufacturer P/N WPCM450RA0BX). The Nuvoton WPCM450 has all the features described above plus IPMI 2.0 support. This particular chip is installed in the X8SIT-F motherboard model.



Note: For more information on IPMI configuration, please refer to the Embedded IPMI User's Guide posted on our website @ <http://www.supermicro.com/support/manuals/>. For detailed information regarding Nuvoton BMC products, go to Nuvoton's website at <http://www.nuvoton.com> and enter the manufacturer part numbers mentioned above in the website's Product Search.

Notes

Chapter 2

Installation

2-1 Electro-Static Sensitive Devices

Electro-Static Discharge (ESD) can damage electronic components. To prevent damage to your system board, it is important to handle it very carefully. The following measures are generally sufficient to protect your equipment from ESD.

Precautions

- Use a grounded wrist strap designed to prevent static discharge.
- Touch a grounded metal object before removing the board from the antistatic bag.
- Handle the board by its edges only; do not touch its components, peripheral chips, memory modules or gold contacts.
- When handling chips or modules, avoid touching their pins.
- Put the motherboard and peripherals back into their antistatic bags when not in use.
- For grounding purposes, make sure your computer chassis provides excellent conductivity between the power supply, the case, the mounting fasteners and the motherboard.
- Use only the correct type of onboard CMOS battery. Do not install the onboard upside down battery to avoid possible explosion.

Unpacking

The motherboard is shipped in antistatic packaging to avoid static damage. When unpacking the board, make sure the person handling it is static protected.

2-2 Processor and Heatsink Installation



Warning: When handling the processor package, avoid placing direct pressure on the label area of the fan.



Notes:

Always connect the power cord last and always remove it before adding, removing or changing any hardware components. Make sure that you install the processor into the CPU socket before you install the CPU heatsink.

If you buy a CPU separately, make sure that you use an Intel-certified multi-directional heatsink only.

Make sure to install the serverboard into the chassis before you install the CPU heatsinks.

When receiving a serverboard without a processor pre-installed, make sure that the plastic CPU socket cap is in place and none of the socket pins are bent; otherwise, contact your retailer immediately.

Refer to the Supermicro web site for updates on CPU support.

Installing the LGA1156 Processor

1

Press the load lever to release the load plate, which covers the CPU socket, from its locking position.

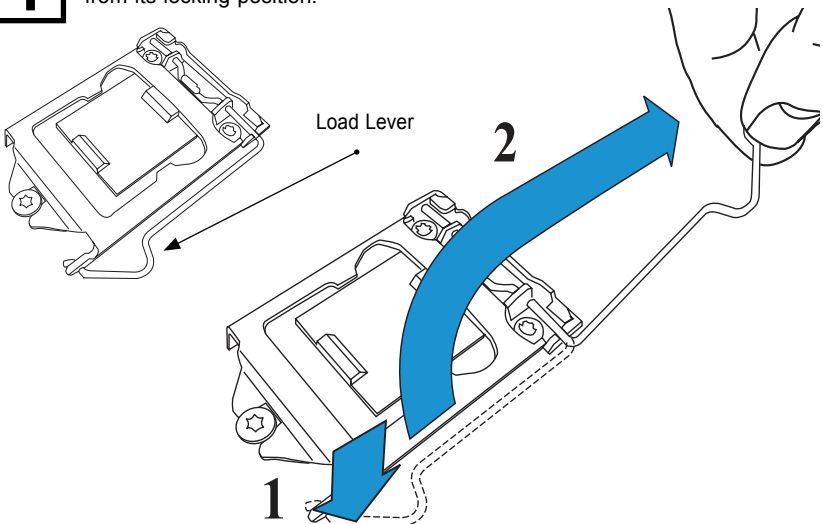

2

Gently lift the load lever to open the load plate. Remove the plastic cap.

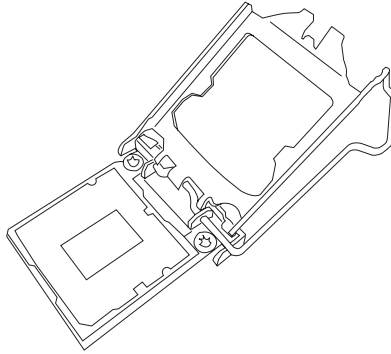
**3**

Use your thumb and your index finger to hold the CPU at the top center edge and the bottom center edge of the CPU.

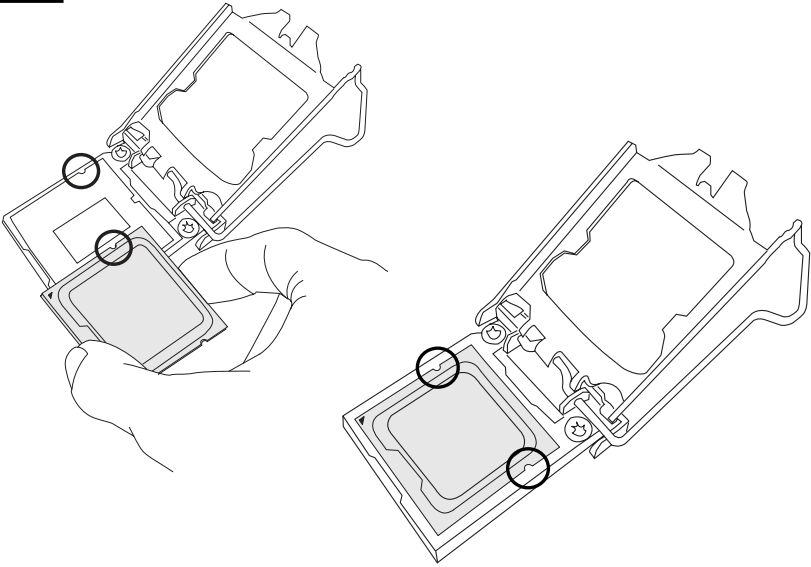
**4**

Align the CPU key that is the semi-circle cutouts against the socket keys. Once the CPU key is aligned, carefully lower the CPU straight down to the socket. (Do not drop the CPU on the socket. Do not move the CPU horizontally or vertically.)

Do not rub the CPU against the surface or against any pins of the socket to avoid damage to the CPU or the socket.)

With the CPU inside the socket, inspect the four corners of the CPU to make sure that the CPU is properly installed.

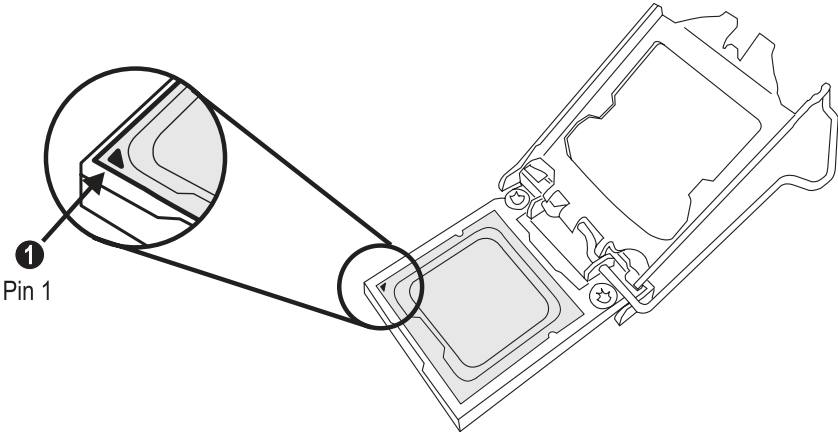

5 Use your thumb to gently push the load lever down to the lever lock.

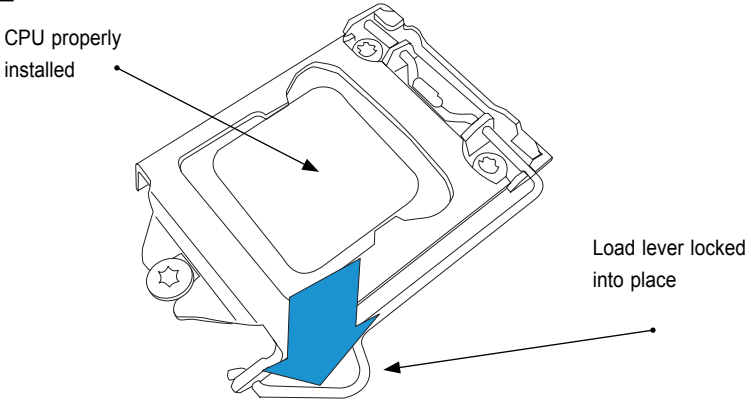

Warning: The CPU will only seat inside the socket in one direction. Make sure it is properly inserted before closing the load plate. If it doesn't close properly, do not force it as it may damage your CPU. Instead, open the load plate again and double-check if the CPU is aligned properly.

Installing a Passive CPU Heatsink

- 1** Do not apply any thermal grease to the heatsink or the CPU die -- the required amount has already been applied.
- 2** Place the heatsink on top of the CPU so that the four mounting holes are aligned with those on the Motherboard's and the Heatsink Bracket underneath.
- 3** Screw in two diagonal screws (i.e., the #1 and the #2 screws) until just snug (do not over-tighten the screws to avoid possible damage to the CPU.)
- 4** Finish the installation by fully tightening all four screws.

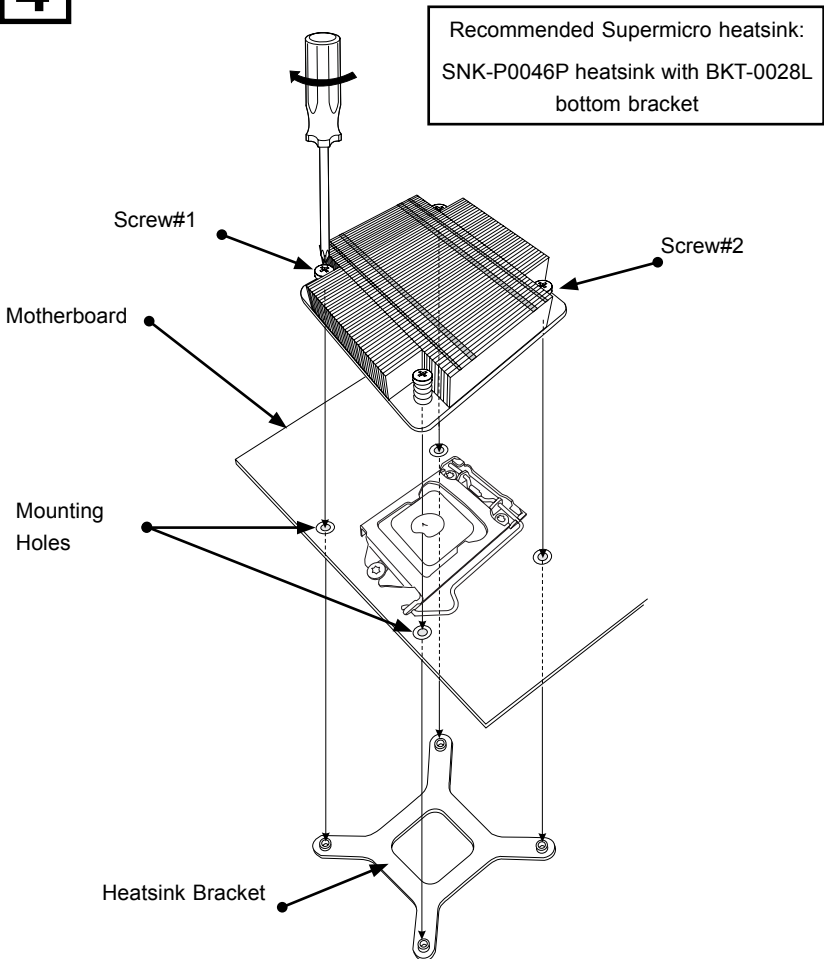

Removing the Heatsink



Warning: We do not recommend that the CPU or the heatsink be removed. However, if you do need to uninstall the heatsink, please follow the instructions below to uninstall the heatsink to prevent damage done to the CPU or the CPU socket.

- 1** Unscrew the heatsink screws from the motherboard in the sequence as shown in the illustration below.
- 2** Gently wriggle the heatsink to loosen it from the CPU. (Do not use excessive force when wriggling the heatsink!!)
- 3** Once the CPU is loosened, remove the heatsink from the CPU socket.
- 4** Clean the surface of the CPU and the heatsink, removing the used thermal grease. Reapply the proper amount of thermal grease on the surface before re-installing the CPU and the heatsink.

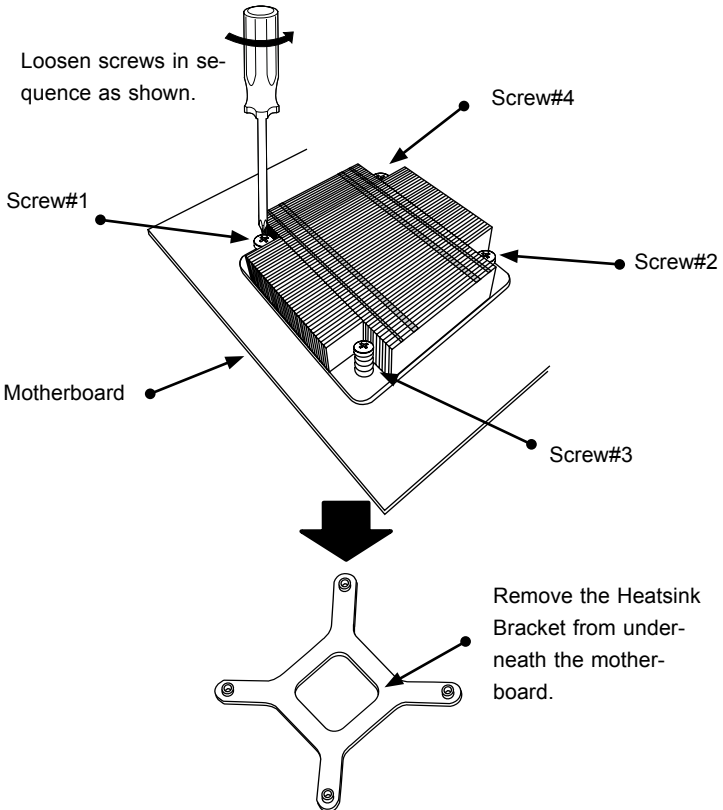

2-3 System Memory



CAUTION

Exercise extreme care when installing or removing DIMM modules to prevent any possible damage.



Note: Check the Supermicro website for a list of memory modules that have been validated with the X8SIT-F motherboard.

How to Install DIMMs

1. Insert the desired number of DIMMs into the memory slots, starting with DIMM1A (Slot 1, Channel A - see Figure A on the following page). Insert each DIMM module vertically into its slot. Pay attention to the notch along the bottom of the module to prevent incorrect DIMM module installation.
2. Gently press down on the DIMM module until it snaps into place in the slot. Repeat step 1 to install DIMM1B if needed. See Page 3-13 for details.

Memory Support

The X8SIT-F supports up to 16GB of DDR3 ECC UDIMM or up to 32GB of ECC DDR3 RDIMM (1333/1066/800 MHz in 6 DIMM slots.) Populating these DIMM modules with a pair of memory modules of the same type and same size will result in interleaved memory, which will improve memory performance. Please refer to the table below:

Platform	DIMM Type	Intel® Xeon® Series Processors
X8SIT-F	Non-ECC UDIMM Only	Not Supported
	ECC UDIMM Only	Supported (see Table 1)
	RDIMM Only (with ECC)	Supported (see Table 2)
	Mixed ECC with non-ECC	Not Supported
	Mixed UDIMM/RDIMM	Not Supported

Table 1 - DDR3 ECC/Unbuffered (UDIMM) Memory Support

ECC UDIMM	1Gb (x8 DRAM)	2Gb (x8 DRAM)
Single Rank	Up to 4GB (4 x 1GB DIMM Modules)*	Up to 8GB (4 x 2GB DIMM Modules)*
Dual Rank	Up to 8GB (4 x 2GB DIMM Modules)*	Up to 16GB (4 x 4GB DIMM Modules)*
Quad Rank	Not Supported	Not Supported



*Note: For ECC UDIMMs, only Slot 1 and Slot 2 may be populated per channel.

RDIMM	1Gb (x8 DRAM)	2Gb (x8 DRAM)
Single Rank	Up to 6GB (6 x 1GB DIMM Modules)	Up to 12GB (6 x 2GB DIMM Modules)
Dual Rank	Up to 12GB (6 x 2GB DIMM Modules)	Up to 24GB (6 x 4GB DIMM Modules)
Quad Rank	Up to 16GB (4 x 4GB DIMM Modules)**	Up to 32GB (4 x 8GB DIMM Modules)**

 **Note:** All other memory sizes, types, die, density, that are not listed in these tables are NOT supported. **For Quad Rank RDIMMs, only Slot 1 and Slot 2 are populated per channel.

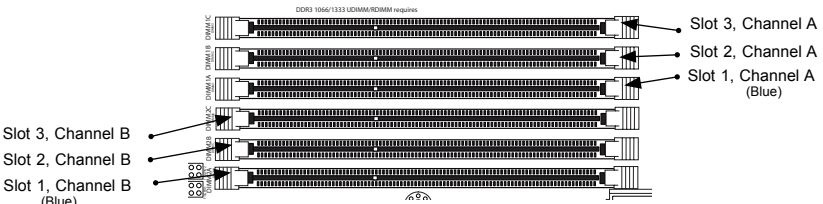

Memory Population Guidelines

Please follow the tables below when populating the X8SIT-F.

DDR3 ECC UDIMM Memory				
DIMM Slots per Channel	DIMMs Populated per Channel	DIMM Type	POR Speeds	Ranks per DIMM (any combination)
3	1	Unbuffered DDR3 ECC	1066, 1333	Single Rank, Dual Rank
3	2	Unbuffered DDR3 ECC	1066, 1333	Single Rank, Dual Rank
3	3	N/A	Not Supported	Single Rank, Dual Rank

 **Note:** For ECC UDIMMs , only Slot 1 and/or Slot 2 may be populated per channel.

DDR3 ECC RDIMM Memory				
DIMM Slots per Channel	DIMMs Populated per Channel	DIMM Type	POR Speeds	Ranks per DIMM (any combination)
3	1	Registered DDR3 ECC	1066, 1333	Single Rank, Dual Rank
3	1	Registered DDR3 ECC	1066	Quad Rank
3	2	Registered DDR3 ECC	1066, 1333	Single Rank, Dual Rank
3	2	Registered DDR3 ECC	800***	Quad Rank
3	3	Registered DDR3 ECC	800***	Single Rank, Dual Rank
3	3	N/A	Not Supported	Quad Rank



***Note: The BIOS will automatically reduce the clock speed to 800MHz for RDIMMs rated at 1066MHz and above.

Installing and Removing DIMMs

1 Position the DIMM module's bottom key, so it aligns with the receptive point on the slot.

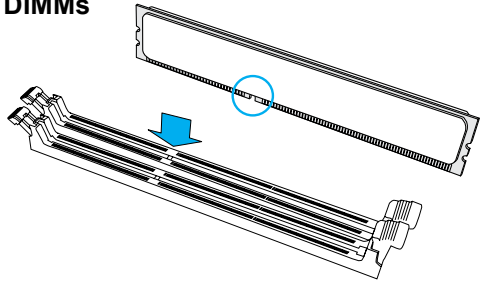

2 Push the Lock/Release tabs to their Release positions. Make sure that the DIMM module's side notches align with the slot's Lock/Release tabs as it is pressed in.

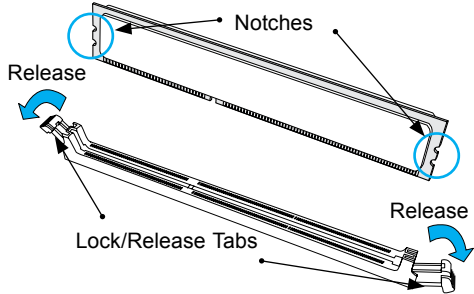

3 Insert the DIMM module vertically and press down until the module snaps into place.

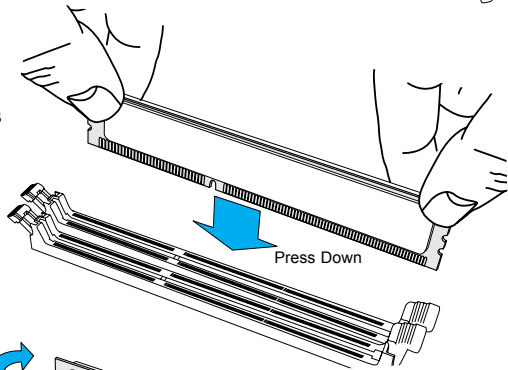

4 When the module is properly inserted, the Lock/Release tabs will automatically secure the DIMM module, locking it into place.

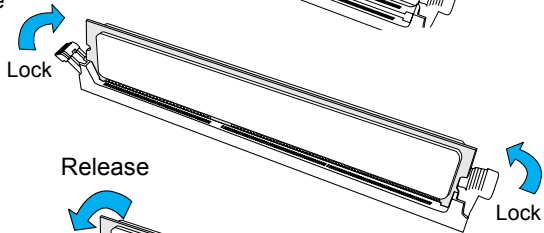

5 To Remove: Use your thumbs to gently push the Lock/Release tabs near both ends of the module. This should release it from the slot. Pull the DIMM module upwards.

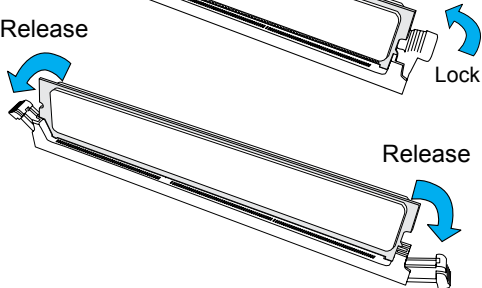



Note: Due to memory allocation to system devices, the amount of memory that remains available for operational use will be reduced when 4 GB of RAM is used. The reduction in memory availability is disproportional.

For Microsoft Windows users: Microsoft implemented a design change in Windows XP with Service Pack 2 (SP2) and Windows Vista. This change is specific to the Physical Address Extension (PAE) mode behavior which improves driver compatibility. For more information, please read the following article at Microsoft's Knowledge Base website at: <http://support.microsoft.com/kb/888137>.

Possible System Memory Allocation & Availability		
System Device	Size	Physical Memory Remaining (-Available) (4 GB Total System Memory)
Firmware Hub flash memory (System BIOS)	1 MB	3.99
Local APIC	4 KB	3.99
Area Reserved for the chipset	2 MB	3.99
I/O APIC (4 Kbytes)	4 KB	3.99
PCI Enumeration Area 1	256 MB	3.76
PCI Express (256 MB)	256 MB	3.51
PCI Enumeration Area 2 (if needed) -Aligned on 256-MB boundary-	512 MB	3.01
VGA Memory	16 MB	2.85
TSEG	1 MB	2.84
Memory available to OS and other applications		2.84

2-4 Motherboard Installation

All motherboards have standard mounting holes to fit different types of chassis. Make sure that the locations of all the mounting holes for both motherboard and chassis match. Although a chassis may have both plastic and metal mounting fasteners, metal ones are highly recommended because they ground the motherboard to the chassis. Make sure that the metal standoffs click in or are screwed in tightly. Then use a screwdriver to secure the motherboard onto the motherboard tray.

Tools Needed

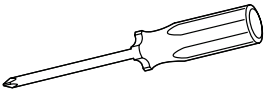

Philips Screwdriver



Pan head screws (7 pieces)



Stand Offs (7 pieces)
(Only if needed)

Location of Mounting Holes

There are seven (7) mounting holes on this motherboard (image rotated -90 degrees) indicated by the arrows.

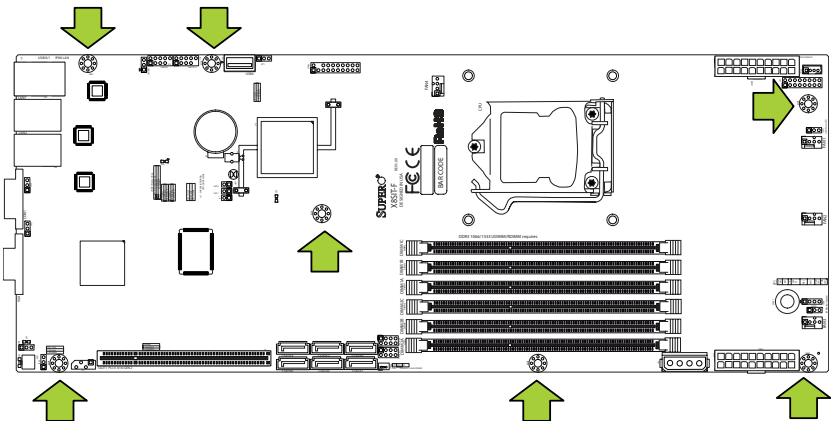

Caution: 1) To avoid damaging the motherboard and its components, please do not use a force greater than 8 lb/inch on each mounting screw during motherboard installation. 2) Some components are very close to the mounting holes. Please take precautionary measures to prevent damage to these components when installing the motherboard to the chassis.

Installation Instructions

1

Locate the mounting holes on the motherboard. Refer to the layout on the previous page for mounting hole locations.

2

Locate the matching mounting holes on the chassis. Install standoffs in the chassis as needed. Align the mounting holes on the motherboard against the mounting holes on the chassis.

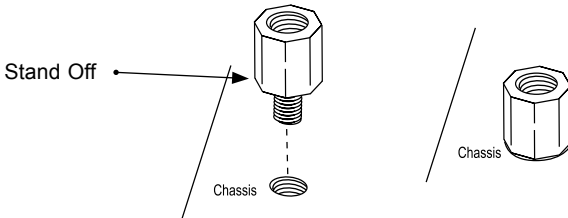
**3**

Install the motherboard into the chassis carefully to avoid damage to motherboard components.

4

Insert a Pan head #6 screw into a mounting hole on the motherboard and its matching mounting hole on the chassis, using a Philips screwdriver.

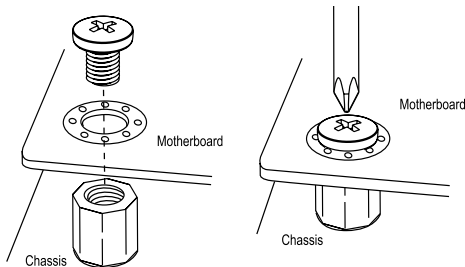
**5**

Repeat Step 4 to insert #6 screws into all mounting holes.

6

Make sure that the motherboard is securely placed in the chassis.

2-5 Connectors/IO Ports

The I/O ports are color coded in conformance with the PC 99 specification. See the figure below for the colors and locations of the various I/O ports.

Back Panel Connectors and IO Ports

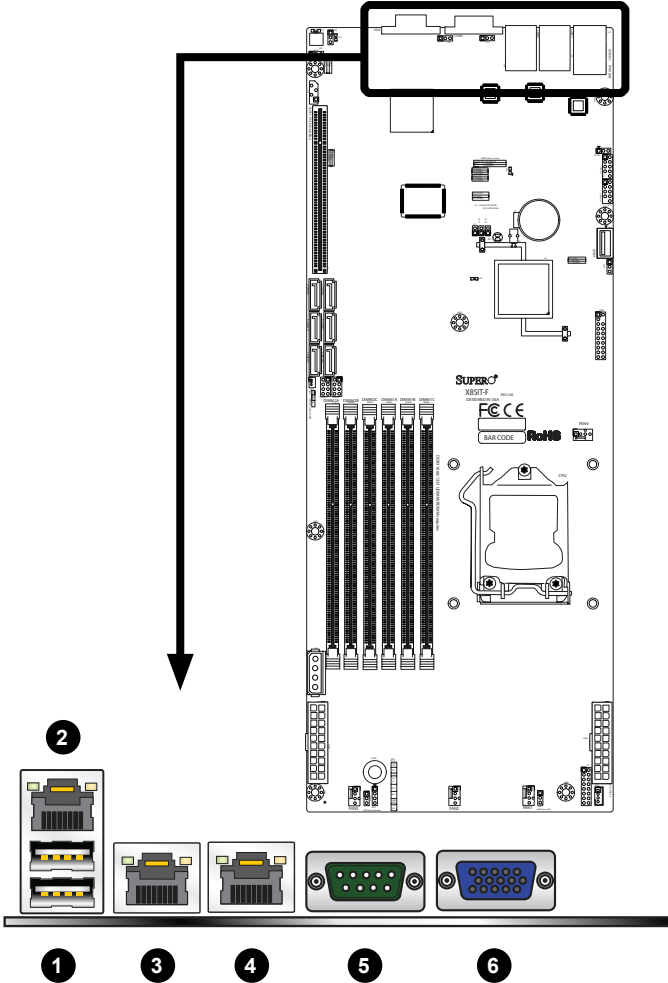

Back Panel Connectors

1. USB 0/1	4. LAN2 Port
2. IPMI LAN Port	5. COM1 Port
3. LAN1 Port	6. VGA Port

Universal Serial Bus (USB)

Two Universal Serial Bus ports (USB 0/1) are located on the I/O back panel and an additional four USB headers, USB 2/3 and USB 10/11 provide front chassis access. USB 4 is a Type A USB Connector. (USB Cables are not included). See the tables on the right for pin definitions.

1. Backplane USB 0/1
2. Front Panel USB Header 2/3
3. Front Panel USB Header 10/11
4. Internal 'Type A' USB 4

Back Panel USB 0/1 Pin Definitions			
Pin#	Definition	Pin#	Definition
1	+5V	5	+5V
2	USB_PN1	6	USB_PN0
3	USB_PP1	7	USB_PP0
4	Ground	8	Ground

Front Panel USB 2/3, 10/11 Pin Definitions			
USB 2, 3		USB 10/11	
Pin #	Definition	Pin #	Definition
1	+5V	6	+5V
2	USB_PN2	7	USB_PN3
3	USB_PP2	8	USB_PP3
4	Ground	9	Ground
5	No Connection	10	Key

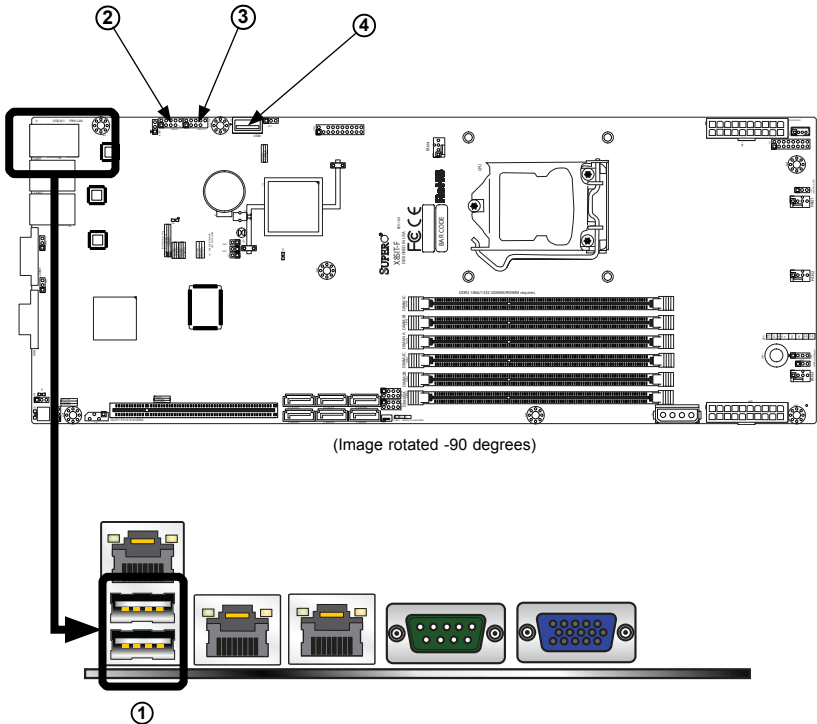

Ethernet Ports

Two Ethernet ports (LAN1/LAN2) are located next to the COM1 port on the I/O back panel. An IPMI Dedicated LAN port is also located above USB ports 0/1 on the X8SIT-F. This provides a dedicated network connection for IPMI 2.0 support. These ports accept RJ45 type connectors/cables.

LAN Ports Pin Definition			
Pin#	Definition		
1	GND	10	TD0-
2	Vcc19-LAN	11	Link 1000 LED
3	TD3+	12	Link 100 LED
4	TD3-	13	3.3V
5	TD2+-	14	Act LED
6	TD2-	15	GND
7	TD1+-	16	GND
8	TD1-		
9	TD0+		

- 1. Dedicated IPMI LAN
- 2. LAN1
- 3. LAN2

(NC: No Connection)

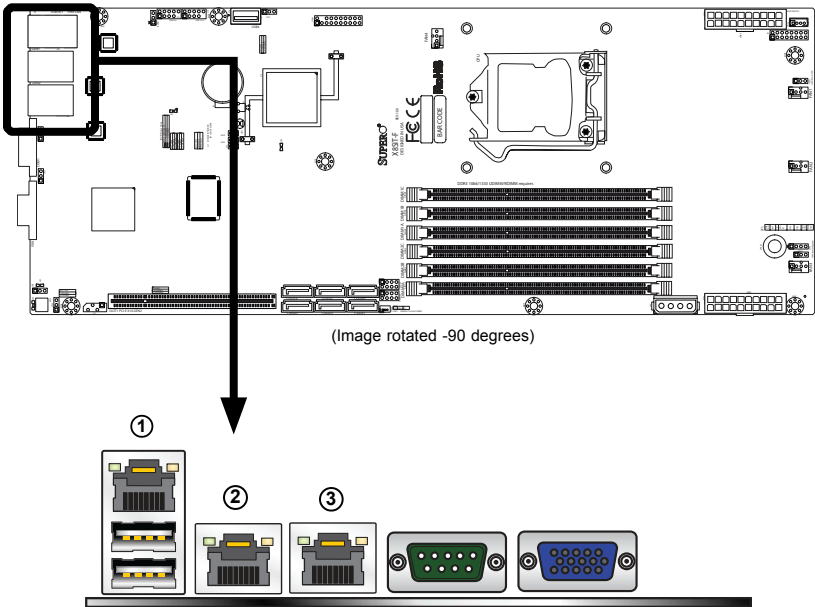

Serial Port

The COM1 Port is located on the I/O back panel. See the table on the right for pin definitions.

Serial Port Pin Definitions (COM1)			
Pin #	Definition	Pin #	Definition
1	CDC	6	DSR
2	RXD	7	RTS
3	TXD	8	CTS
4	DTR	9	RI
5	Ground	10	NC

1. COM1

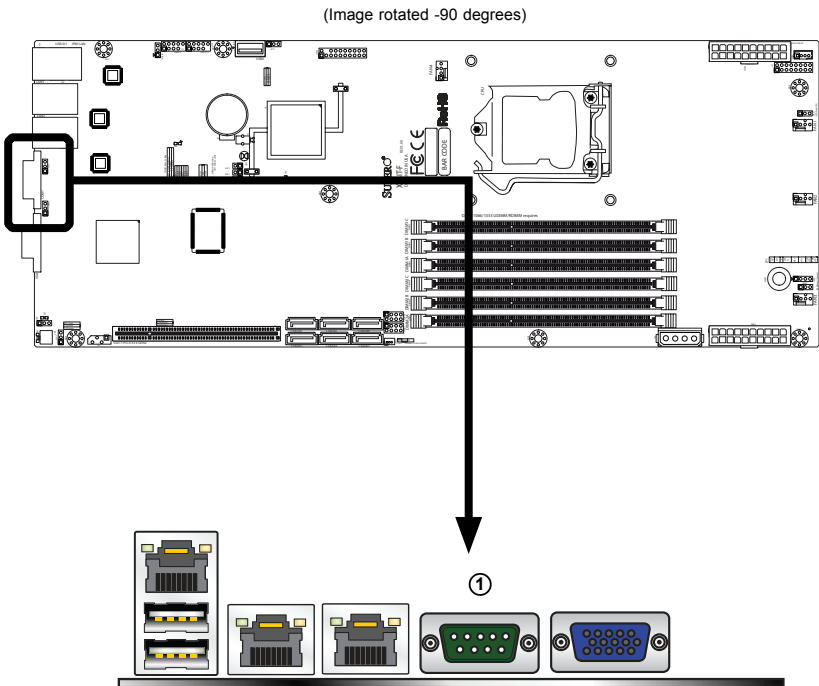

Video Connector

A Video (VGA) connector is located next to the COM Port on the I/O back panel. This connector is used to provide video signals to the display. Refer to the board layout below for the location.

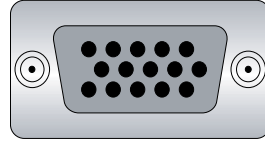

1. VGA

(Image rotated -90 degrees)

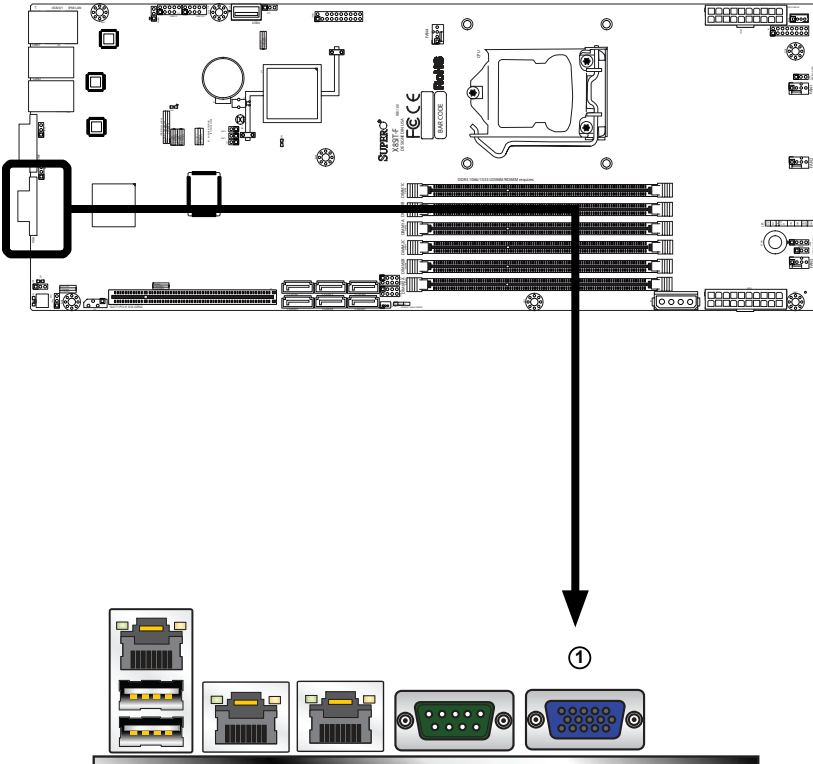

Front Control Panel

JF1 contains header pins for various buttons and indicators that are normally located on a control panel at the front of the chassis. These connectors are designed specifically for use with Supermicro server chassis. See the figure below for the descriptions of the various control panel buttons and LED indicators. Refer to the following section for descriptions and pin definitions.

JF1 Header Pins

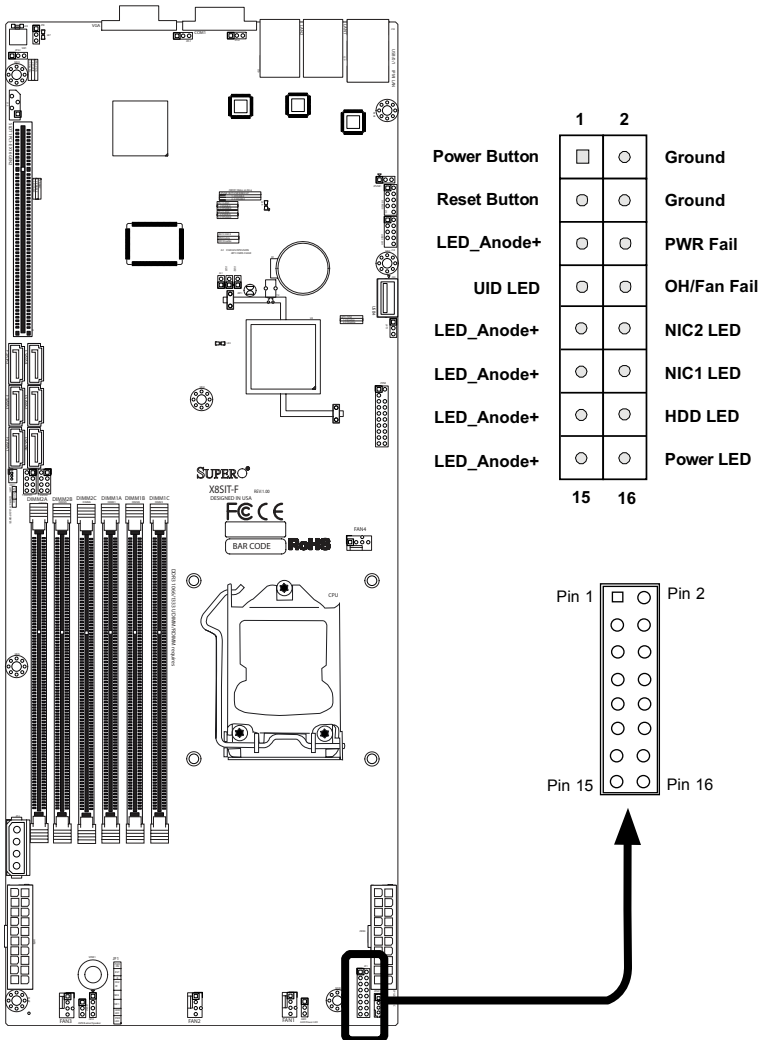

Front Control Panel Pin Definitions

Power LED

The Power LED connection is located on pins 15 and 16 of JF1. Refer to the table on the right for pin definitions.

Power LED Pin Definitions (JF1)	
Pin#	Definition
15	+5V
16	Ground

HDD LED

The HDD LED connections are located on pins 13 and 14 of JF1. Attach a cable here to indicate HDD activity. See the table on the right for pin definitions.

HDD LED Pin Definitions (JF1)	
Pin#	Definition
13	+5V
14	HD Active

Power Fail LED

The Power Fail LED connection is located on pins 5 and 6 of JF1. Attach an LED cable here to indicate when there has been a power outage. Refer to the table on the right for pin definitions.

PWR Fail LED Pin Definitions (JF1)	
Pin#	Definition
5	Vcc
6	Ground

A. PWR LED

B. HDD LED

C. PWR Fail LED

	1	2	
Power Button	□	○	Ground
Reset Button	○	○	Ground
LED_Anode+	○	○	PWR Fail C
UID LED	○	○	OH/Fan Fail
LED_Anode+	○	○	NIC2 LED
LED_Anode+	○	○	NIC1 LED
LED_Anode+	○	○	HDD LED B
LED_Anode+	○	○	Power LED A
	15	16	

NIC1/NIC2 (LAN1/LAN2)

The NIC (Network Interface Controller) LED connection for LAN port 1 is located on pins 11 and 12 of JF1, and the LED connection for LAN Port 2 is on Pins 9 and 10. NIC1 LED and NIC2 LED are 2-pin NIC LED headers. Attach NIC LED cables to NIC1 LED and NIC2 LED to display network activities for LAN 1 and LAN2. Refer to the table on the right for pin definitions.

LAN1/LAN2 LED Pin Definitions (JF1)	
Pin#	Definition
9/11	Vcc
10/12	LAN Act

OH/Fan Fail LED Pin Definitions (JF1)	
Pin#	Definition
7	Vcc/Blue UID LED
8	OH/Fan Fail LED

OH/Fan Fail Indicator Status	
State	Definition
Off	Normal
On	Overheat
Flash- ing	Fan Fail

Overheat (OH)/Fan Fail/Front UID LED

Connect an LED cable to the Front UID and OH/Fan Fail connections on pins 7 and 8 of JF1 to display UID (Unit ID) signals or to provide advanced warnings for chassis overheat/fan failure. Refer to the table on the right for pin definitions.

A. NIC1 LED

B. NIC2 LED

C. OH/Fan Fail

	1	2	
Power Button	□	○	Ground
Reset Button	○	○	Ground
LED_Anode+	○	○	PWR Fail
UID LED	○	○	OH/Fan Fail C
LED_Anode+	○	○	NIC2 LED B
LED_Anode+	○	○	NIC1 LED A
LED_Anode+	○	○	HDD LED
LED_Anode+	○	○	Power LED
	15	16	

Reset Button

The Reset Button connection is located on pins 3 and 4 of JF1. Attach it to a the hardware Reset Button on the computer case. Refer to the table on the right for pin definitions.

Reset Button Pin Definitions (JF1)	
Pin#	Definition
3	Reset
4	Ground

Power Button

The Power Button connection is located on pins 1 and 2 of JF1. Momentarily contacting both pins will power on/off the system. This button can also be configured to function as a suspend button (see BIOS Setup). To turn off the power in the suspend mode, press the button for at least 4 seconds. Refer to the table on the right for pin definitions.

Power Button Pin Definitions (JF1)	
Pin#	Definition
1	Signal
2	GND

[A Reset Button](#)

[B_PWR Button](#)

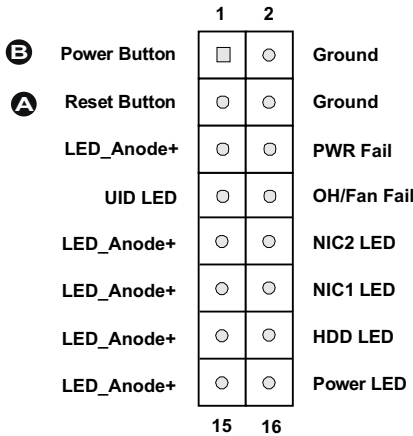

2-6 Connecting Cables

This section provides brief descriptions and pin-out definitions for onboard headers and connectors. Be sure to use the correct cable for each header or connector.

20-pin Proprietary Power Connectors

There are two 20-pin main power supply connectors (JWR3, JWR4) and a 4-pin auxiliary power connector (JP3) on the motherboard. These power connectors meet the SSI EPS 12V specification. For power supply to work properly, please follow the instructions given below. See the table on the right for pin definitions. Also refer to the layout below for the PWR connector locations.



Note 1: You cannot use both 20-pin power connectors located at JWR3 and JWR4 at the same time. Only one connector can be used for input power supply to the motherboard at a time. For proper use of these proprietary PWR Connectors, please customize your PWR Cables based on the SMC PWR Connector Pin-Out Definitions listed above.

20-pin Main Power Connector Pin Definitions			
Pin#	Definition	Pin #	Definition
11	PS On	1	Ground
12	5VSB	2	Ground
13	Ground	3	Ground
14	Ground	4	Ground
15	Ground	5	Ground
16	NC2	6	NC1
17	12V	7	12V
18	12V	8	12V
19	12V	9	12V
20	12V	10	12V

A. 20-pin PWR connector: (JWR3)

B. 20-pin PWR connector: (JWR4)

C. 4-pin Auxiliary Power (JP3)

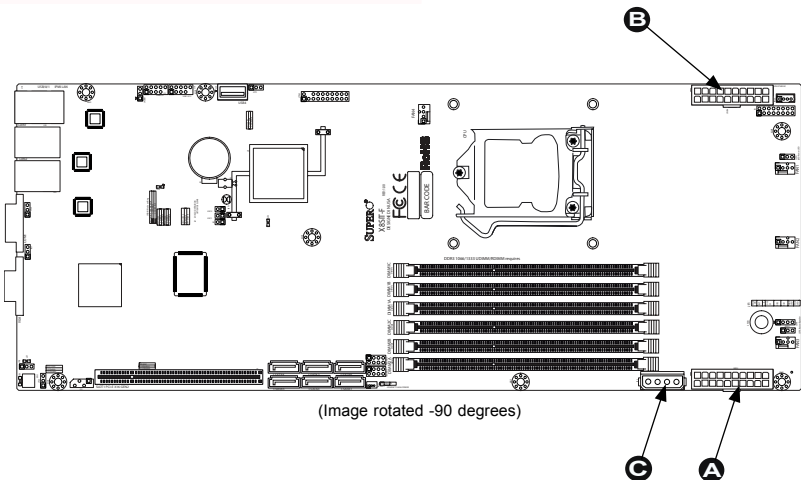

Fan Headers

The X8SIT-F has four fan headers (Fan1 ~ Fan4). These fans are 4-pin fan headers. However, Pins 1-3 of the fan headers are backward compatible with the traditional 3-pin fans. A fan speed control setting in the BIOS Hardware Monitoring section allows the BIOS to automatically set fan speeds based on the system temperature. The default setting is **Disabled** which allows the onboard fans to run at full speed. Refer to the table on the right for pin definitions.

Fan Header Pin Definitions	
Pin#	Definition
1	Ground (Black)
2	+12V (Red)
3	Tachometer
4	PWM_Control



Note: Please use all 3-pin fans or all 4-pin fans on a motherboard. Please do not use 3-pin fans and 4-pin fans on the same board.

Chassis Intrusion

A Chassis Intrusion header is located at JL1 on the motherboard. Attach the appropriate cable from the chassis to inform you of a chassis intrusion when the chassis is opened.

- A. Fan1
- B. Fan2
- C. Fan3
- D. Fan4 (CPU Fan)
- E. Chassis Intrusion

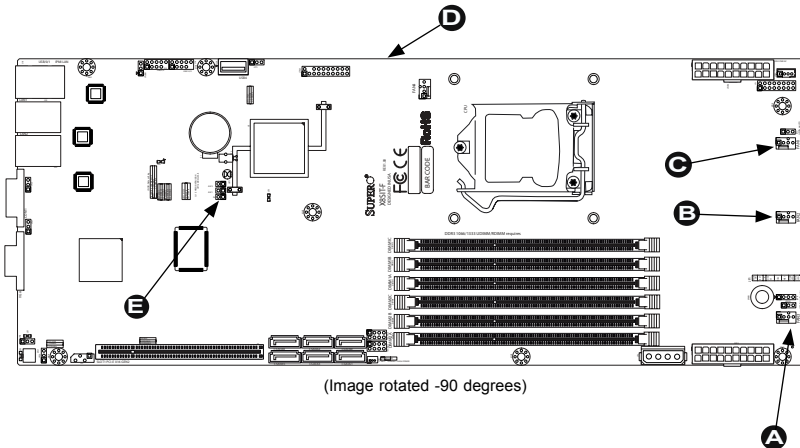

Internal Speaker/Buzzer

The Internal Speaker/Buzzer (SPKR1) can be used to provide audible indications for various beep codes. See the table on the right for pin definitions. Refer to the layout below for the location of the Internal Speaker/Buzzer.

Internal Buzzer Pin Definition		
Pin#	Definitions	
Pin 1	Pos. (+)	Beep In
Pin 2	Neg. (-)	Alarm Speaker

External Speaker

On the JD1 header, Pins 3~4 are used to activate the Internal Speaker/Buzzer. Close Pins 3~4 with a jumper to use the Internal Speaker/Buzzer. If you wish to use an external speaker, attach the external speaker's cable to Pins 1~4. See the table on the right for pin definitions.

Speaker Connector Pin Definitions	
Pin Setting	Definition
Pins 3~4	Internal Speaker
Pins1~4	External Speaker

A. Internal Buzzer

B. Speaker Header

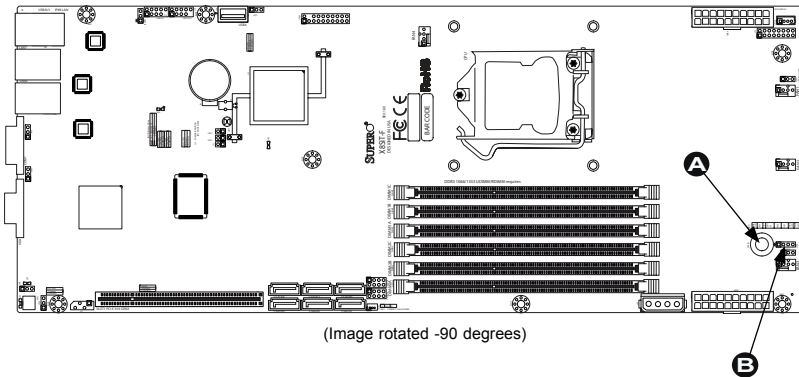

Onboard Power LED

An onboard Power LED header is located at JLED. This Power LED header is connected to Front Control Panel located at JF1 to indicate the status of system power. See the table on the right for pin definitions.

Onboard PWR LED Pin Definitions	
Pin#	Definition
1	VCC
2	No Connection
3	Connection to PWR LED in JF1

Power Supply I²C Connector

Power Supply (I²C) Connector, located at JPIC on the motherboard. This connector monitors the status of the power supply, fan and system temperature. See the table on the right for pin definitions.

PWR Supply I ² C Pin Definitions	
Pin#	Definition
1	Clock
2	Data
3	PWR Fail
4	Ground

A. PWR LED

B. PWR SMB

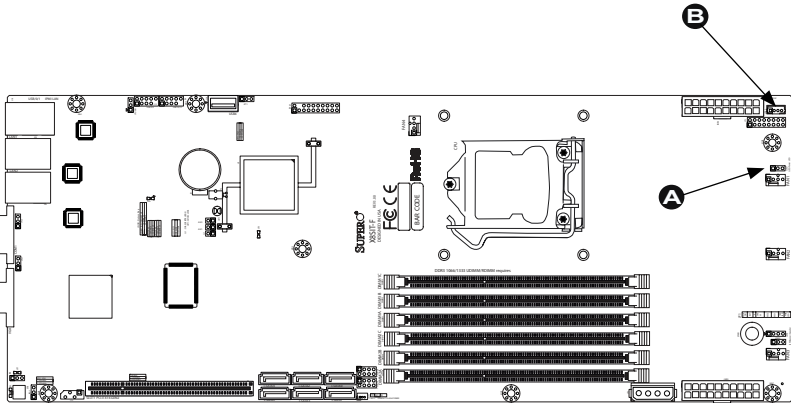

(Image rotated -90 degrees)

T-SGPIO 0/1 Headers

Two T-SGPIO (Serial-Link General Purpose Input/Output) headers are located near the SATA connectors on the motherboard. These headers are used to communicate with the enclosure management chip in the system. See the table on the right for pin definitions. Refer to the board layout below for the locations of the headers.

Serial_Link-SGPIO Pin Definitions			
Pin#	Definition	Pin	Definition
2	NC	1	NC
4	Data Out	3	Ground
6	Ground	5	Load
8	NC	7	Clock

NC: No Connections

Compact Flash/DOM PWR Connector

A Compact Flash/Disk On Module (DOM) Power Connector is located at JWF1. This connector is used to provide power to auxiliary flash memory media that is attached to the SATA port. Refer to the board layout below for the location.

Compact Flash Card PWR Connector	
Pin	Definition
1	Vcc
2	GND
3	GND

A. T-SGPIO 1

B. T-SGPIO 2

C. CF/DOM Power

(Image rotated -90 degrees)

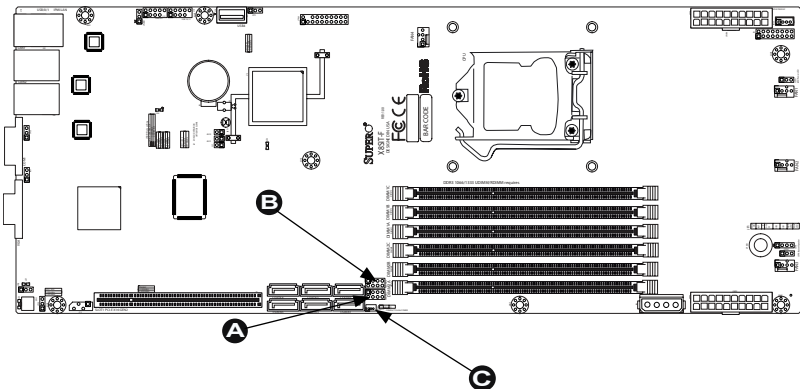

Trusted Platform Module Header

This header is used to connect a Trusted Platform Module (TPM), available separately from a third-party vendor. A TPM is a security device that allows encryption and authentication of hard drives, disallowing access if the TPM associated with it is not installed in the system. See the table on the right for pin definitions.

Trusted Platform Module Header Pin Definitions			
Pin #	Definition	Pin #	Definition
1	LCLK	2	GND
3	LFRAME	4	No Pin
5	LRESET	6	VCC5
7	LAD3	8	LAD2
9	VCC3	10	LAD1
11	LAD0	12	GND
13	RSV0	14	RSV1
15	SB3V	16	SERIRQ
17	GND	18	CLKRUN
19	LPCPD	20	RSV2

A. TPM Header

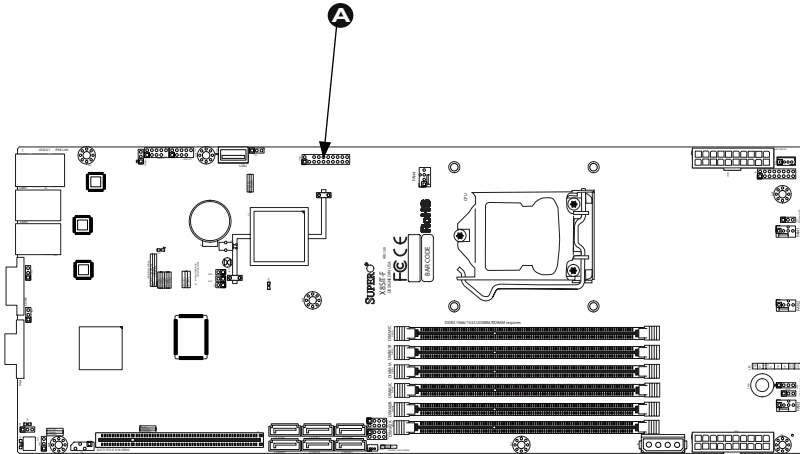

(Image rotated -90 degrees)

Unit ID Switch

There are three Unit Identification (UID) devices on the motherboard. A rear UID switch and a rear UID LED indicator. The Front Panel UID LED is connected to a pin in the Front Control Panel (Pin 7 of JF1). When the user pushes the rear UID switch, the Front Panel UID LED and the back panel UID LED (LE5) will turn on. Push the rear UID switch again to turn off both Indicators. These UID Indicators provide easy identification of a system unit that may be in need of service.

UID Switch	
Pin#	Definition
1	Ground
2	Ground
3	Button In
4	Ground

IPMB

A System Management Bus (SMB) header for IPMI 2.0 is located at IPMB. Connect the appropriate cable here to use the IPMB I²C connection on your system.

SMB Header Pin Definition	
Pin#	Definition
1	Data
2	Ground
3	Clock
4	No Connection

A. UID Switch

B. IPMB

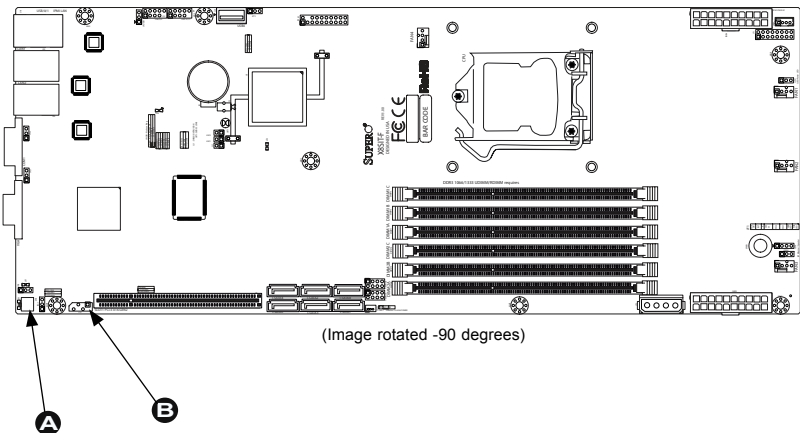

2-7 Jumper Settings

Explanation of Jumpers

To modify the operation of the motherboard, jumpers can be used to choose between optional settings. Jumpers create shorts between two pins to change the function of the connector. Pin 1 is identified with a square solder pad on the printed circuit board.



Note: On two pin jumpers, "Closed" means the jumper is on and "Open" means the jumper is off the pins.

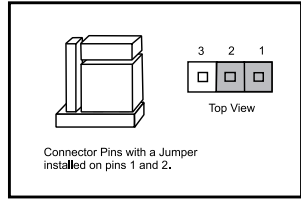
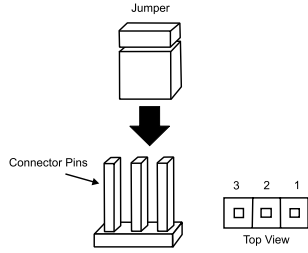

LAN Port Enable/Disable

Use JPL1/JPL2 to enable or disable LAN Port 1 and LAN Port 2 on the motherboard. See the table on the right for jumper settings. The default setting is enabled.

GLAN Enable Jumper Settings	
Pin#	Definition
1-2	Enabled (default)
2-3	Disabled

A. LAN Port 1 Enable

B. LAN Port 2 Enable

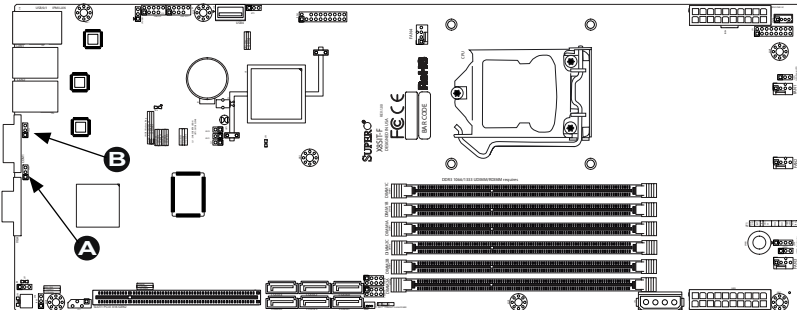

(Image rotated -90 degrees)

CMOS Clear

JBT1 is used to clear CMOS. Instead of pins, this "jumper" consists of contact pads to prevent accidental clearing of CMOS. To clear CMOS, use a metal object such as a small screwdriver to touch both pads at the same time to short the connection. Always remove the AC power cord from the system before clearing CMOS.

Note: For an ATX power supply, you must completely shut down the system, remove the AC power cord and then short JBT1 to clear CMOS.

PCI Slot SMB Enable

Use Jumpers I²C1/I²C2 to enable PCI Slot SMB (System Management Bus) support to improve system management for the PCI slots. See the table on the right for jumper settings.

PCI Slot_SMB Enable Jumper Settings	
Jumper Setting	Definition
Short	Enabled
Open (Default)	Disabled

A. Clear CMOS

B. JI²C1

C. JI²C2

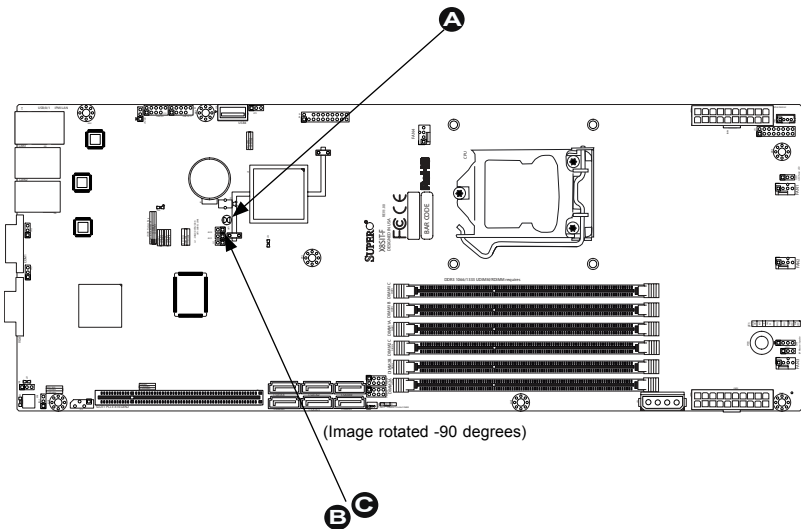

USB Wake-Up

Use the JPUSB1 jumper to "wake-up" your system by pressing a key on a USB keyboard or clicking the USB mouse. The JPUSB1 jumper is used together with the USB Wake-Up feature in the BIOS. Enable this jumper and the USB feature in the BIOS to wake-up your system via USB devices.

JPUSB1 (USB Wake-up Enable)	
Pin#	Definition
1-2	Enabled (Default)
2-3	Disabled

BMC Jumper (JPB)

JPB is used to enable or disable the BMC (Baseboard Management Control) Chip and the onboard IPMI connection. This jumper is used together with the IPMI settings in the BIOS. The default position is on pins 1 and 2 to Enable BMC. See the table on the right for jumper settings.

BMC IPMI Enable/Disable Jumper Settings (JPB)	
Settings	Definition
Pins 1-2	Enabled (Default)
Pins 2-3	Disabled

A. BP USB 0/1 Wake-up

B. BMC Jumper (JPB)

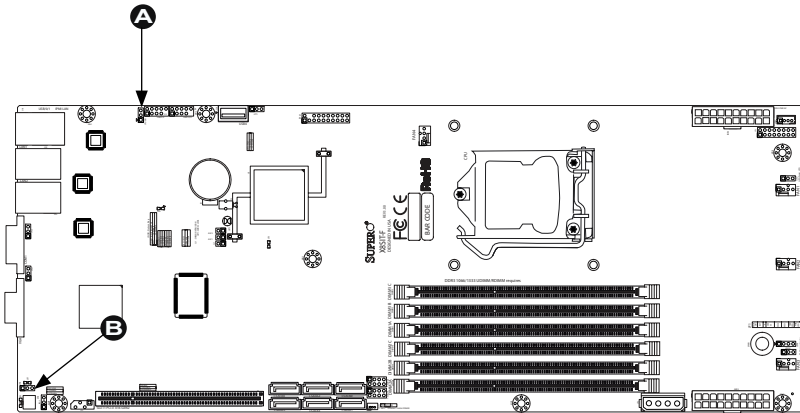

(Image rotated -90 degrees)

VGA Enable

JPG1 allows you to enable or disable the onboard VGA connector. The default position is on pins 1 and 2 to enable VGA. See the table on the right for jumper settings.

VGA Enable/Disable Jumper Settings (JPG1)

Both Jumpers	Definition
Pins 1-2	Enabled (Default)
Pins 2-3	Disabled

TPM Support Enable

JPT1 allows the user to enable TPM (Trusted Platform Module) support to improve data integrity and system security. See the table on the right for jumper settings. The default setting is **Enabled**.

TPM Support Enable Jumper Settings

Jumper Setting	Definition
1-2 (Default)	Enabled
2-3	Disabled

Hot Swap Enable/Disable (JPEN1)

When two X8SIT-F motherboards are installed in a chassis, it is possible to power down one motherboard for servicing while the other continues operating. JPEN1 allows the user to enable motherboard 'hot-swapping', which enables this feature. The default setting is **Enabled**.

Hot Swap Jumper Settings

Jumper Setting	Definition
1-2 (Default)	Enabled
2-3	Disabled

A. VGA Enable

B. TPM Enable

C. Hot Swap Enable (JPEN1)

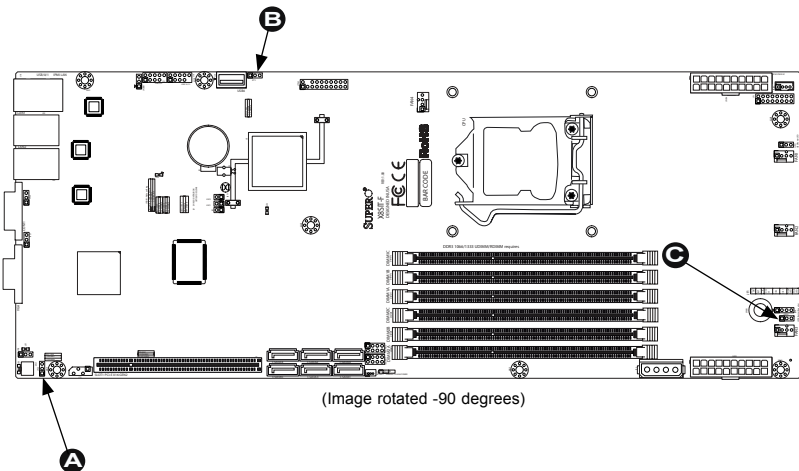

2-8 Onboard Indicators

LAN LEDs

Two LAN ports (LAN 1/LAN 2) are located on the I/O back panel of the motherboard. Each Ethernet LAN port has two LEDs. The yellow LED indicates activity, while the Link LED may be green, amber or off to indicate the connection speed. See the tables at right for more information.

LAN 1~2 Activity LEDs (Yellow)		
Color	Status	Definition
Yellow	Blinking	Active

LAN 1~2 Link LEDs (Green/Amber/Off)	
LED Color	Definition
Off	No Connection or 10 Mbps
Green	100 Mbps
Amber	1 Gbps

IPMI Dedicated LAN

In addition to LAN ports, an IPMI Dedicated LAN is also installed on the X8SIT-F. The yellow LED on the right indicates activity, while the green LED on the left indicates the speed of the connection. See the tables at right for more information.

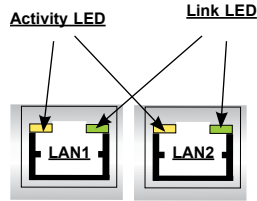

IPMI LAN Link LED (Left) & Activity LED (Right)		
Color	Status	Definition
Link (left)	Green: Solid	100 Mbps
Activity (right)	Yellow: Blinking	Active

- A. LAN Port 1
- B. LAN Port 2
- C. IPMI LAN

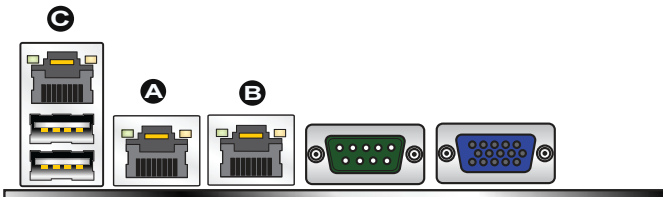

Onboard Standby Power LED

An Onboard Standby Power LED is located at LE1 on the motherboard. When LE1 is on, the AC power cable is connected. Make sure to disconnect the power cable before removing or installing any component. See the layout below for the LED location.

Onboard Standby PWR LED LED Settings	
LED Color	Definition
Off	System Off
On	System on, or System off and PWR Cable Connected

IPMI Heartbeat LED

An IPMI Heartbeat LED is located at LE7. When LE7 blinks, the IPMI functions properly. Refer to the table on the right for details. Also see the layout below for the LED location.

IPMI Heartbeat LED Indicator (LE7) LED Settings	
Green: Blinking	IPMI is ready for use

Rear UID LED

The rear UID LED is located at LE5 on the backplane. This LED is used in conjunction with the front UID LED and the rear UID switch to provide easy identification of a system that might be in need of service.

Memory Status LED

A Memory Status LED is located at LE3. When LE3 blinks, it indicates that a memory error has been detected. Refer to the layout below for the location.

- A. Onboard PWR LED
- B. IPMI Heartbeat LED
- C. UID LED
- D. Memory Status LED

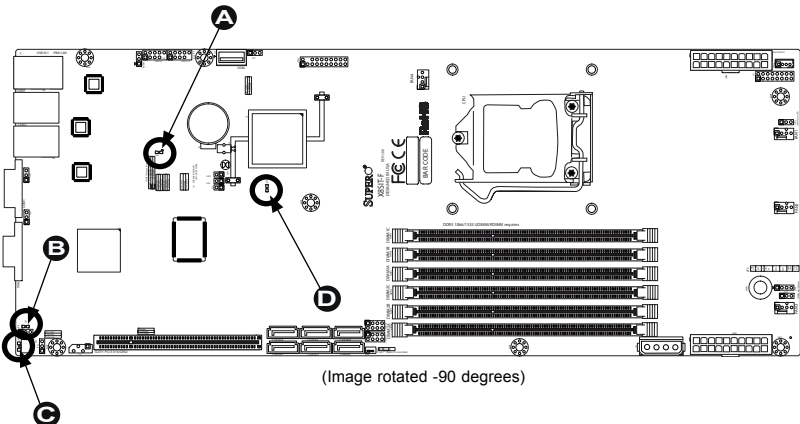

2-9 SATA Drive Connections

SATA Connections

Six Serial ATA (SATA) connectors (I-SATA 0~5) are located on the motherboard. These Serial Link connections provide faster data transmission than legacy Parallel ATA. See the table on the right for pin definitions.

SATA Connectors Pin Definitions	
Pin#	Signal
1	Ground
2	SATA_TXP
3	SATA_TXN
4	Ground
5	SATA_RXN
6	SATA_RXP
7	Ground

- A. I-SATA 0
- B. I-SATA 1
- C. I-SATA 2
- D. I-SATA 3
- E. I-SATA 4
- F. I-SATA 5

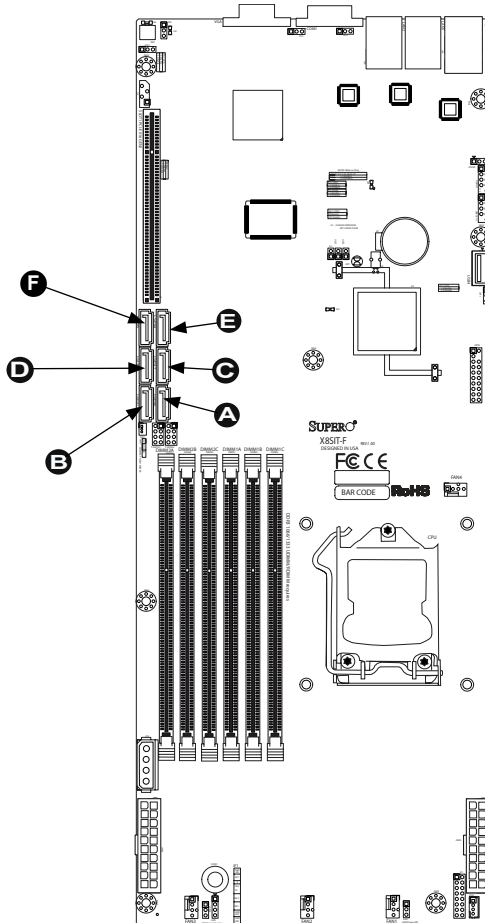

Chapter 3

Troubleshooting

3-1 Troubleshooting Procedures

Use the following procedures to troubleshoot your system. If you have followed all of the procedures below and still need assistance, refer to the 'Technical Support Procedures' and/or 'Returning Merchandise for Service' section(s) in this chapter. Always disconnect the AC power cord before adding, changing or installing any hardware components.

Before Power On

1. Make sure that the Standby PWR LED (LE4) is not lit. (**Note:** If LE4 is on, the system is plugged in. Be sure to unplug the power cable before installing or removing the components.)
2. Make sure that there are no short circuits between the motherboard and chassis.
3. Disconnect all ribbon/wire cables from the motherboard, including those for the keyboard and mouse. Also, be sure to remove all add-on cards.
4. Install a CPU and heatsink (be sure that it is fully seated) and then connect the chassis speaker and the power LED to the motherboard. Check all jumper settings as well.

No Power

1. Make sure that there are no short circuits between the motherboard and chassis.
2. Make sure that all jumpers are set to their default positions.
3. Check if the 115V/230V switch on the power supply is properly set.
4. Turn the power switch on and off to test the system.
5. The battery on your motherboard may be old. Check to make sure that it still supplies ~3VDC. If it does not, replace it with a new one.

No Video

1. If the power is on, but you have no video--in this case, you will need to remove all the add-on cards and cables first.

2. Use the speaker to determine if any beep codes exist. (Refer to Appendix A for details on beep codes.)
3. Remove all memory modules and turn on the system. (If the alarm is on, check the specs of memory modules, reset the memory or try a different one.)

Memory Errors

1. Make sure that the DIMM modules are properly installed and fully seated in the slots.
2. You should be using unbuffered ECC or registered ECC DDR3 (1.5V) 1333/1066/800 MHz memory (recommended by the manufacturer). Also, it is recommended that you use the memory modules of the same type and speed for all DIMMs in the system. Do not mix different sizes, speed, UDIMM and RDIMM, ECC and non-ECC.
3. Check for bad DIMM modules or slots by swapping modules between slots to see if you can locate the faulty modules.
4. Check the power supply voltage 115V/230V switch.

Lost System Setup Configuration

1. Please be sure to use a high quality power supply. A poor quality power supply may cause the system to lose the CMOS setup information. Refer to Section 1-5 for details on recommended power supplies.
2. The battery on your motherboard may be old. Check to verify that it still supplies ~3VDC. If it does not, replace it with a new one.
3. If the above steps do not fix the Setup Configuration problem, contact your vendor for repairs.

3-2 Technical Support Procedures

Before contacting Technical Support, please make sure that you have followed all the steps listed below. Also, Note that as a motherboard manufacturer, Supermicro does not sell directly to end users, so it is best to first check with your distributor or reseller for troubleshooting services. They should know of any possible problem(s) with the specific system configuration that was sold to you.

1. Please go through the 'Troubleshooting Procedures' and 'Frequently Asked Question' (FAQ) sections in this chapter or see the FAQs on our website (<http://www.supermicro.com/support/faqs/>) before contacting Technical Support.

2. BIOS upgrades can be downloaded from our website at (<http://www.supermicro.com/support/bios/>).



Note: Not all BIOS can be flashed. Some cannot be flashed; it depends on the modifications to the boot block code.

3. If you've followed the instructions above to troubleshoot your system, and still cannot resolve the problem, then contact Supermicro's technical support and provide them with the following information:

- Motherboard model and PCB revision number
- BIOS release date/version (this can be seen on the initial display when your system first boots up)
- System configuration

An example of a Technical Support form is on our website at (<http://www.supermicro.com/support/contact.cfm>).

4. Distributors: For immediate assistance, please have your account number ready when placing a call to our technical support department. We can be reached by e-mail at support@supermicro.com, by phone at: (408) 503-8000, option 2, or by fax at (408)503-8019.

3-3 Frequently Asked Questions

Question: What type of memory does my motherboard support?

Answer: The X8SIT-F supports up to 32GB of Registered ECC DDR3 or up to 16GB of unbuffered ECC DDR3 SDRAM (1.5V, 1333/1066/800 MHz). See Section 3-3 for details on installing memory.

Question: Does the X8SIT-F motherboard support non-ECC UDIMM with the Xeon 34xx CPU?

Answer: No. With Xeon 34xx CPUs, memory type has to be either ECC UDIMM or ECC RDIMM. Please refer to our "tested memory list" in our motherboard website. For memory usage guidelines, please check Chapter 2 of this manual.

Question: How do I update my BIOS?

Answer: It is recommended that you **do not** upgrade your BIOS if you are not experiencing any problems with your system. Updated BIOS files are located on our web site at <http://www.supermicro.com/support/bios/>. Please check our BIOS warning message and the information on how to update your BIOS on our

web site. Select your motherboard model and download the BIOS (.rom) file to your computer. Also, check the current BIOS revision and make sure that it is newer than your BIOS before downloading. You may choose the zip file or the .exe file. If you choose the zipped BIOS file, please unzip the BIOS file onto a bootable device or a USB pen/thumb drive. To flash the BIOS, run the batch file named "ami.bat" with the new BIOS .rom file from your bootable device or USB pen/thumb drive. Use the following format:

```
F:\> ami xxxxxxxx.rom <Enter>
```



Notes: Be sure to insert a space after "ami" and always use the file named "ami.bat" to update the BIOS.

When completed, your system will automatically reboot. If you choose the .exe file, please run the .exe file under Windows to create the BIOS flash floppy disk. Insert the floppy disk into the system you wish to flash the BIOS. Then, boot the system to the floppy disk. The BIOS utility will automatically flash the BIOS without any prompts. Please note that this process may take a few minutes to complete. Do not be concerned if the screen is paused for a few minutes.



Warning: Do not shut down or reset the system while updating the BIOS to prevent possible system boot failure!

When the BIOS flashing screen is completed, the system will reboot and will show "Press F1 or F2". At this point, you will need to load the BIOS defaults. Press <F1> to go to the BIOS setup screen, and press <F9> to load the default settings. Next, press <F10> to save and exit. The system will then reboot.



Note: The SPI BIOS chip installed on this motherboard is not removable. To repair or replace a damaged BIOS chip, please send your motherboard to RMA at Supermicro for service.

Question: I think my BIOS is corrupted. How can I recover my BIOS?

Answer: Please see Appendix C, BIOS Recovery for detailed instructions.

Question: What's on the CD that came with my motherboard?

Answer: The supplied compact disc has quite a few drivers and programs that will greatly enhance your system. We recommend that you review the CD and install the applications you need. Applications on the CD include chipset drivers for Windows, security and audio drivers.

Question: How do I solve an error message "IASTOR.SYS read error" when installing Windows and "press F6 to install Intel RAID driver" on my X8SIT-F motherboard?

Answer: To solve this issue, disable the IPMI jumper. Another solution is to use a USB floppy drive instead of the onboard floppy drive. For the IPMI jumper location, please check Chapter 1.

Question: What is the heat sink part number for my X8SIT-F motherboard?

Answer: For the 1U passive heat sink, ask for SNK-P0046P (back plate is included).

Question: Why can't I recover the BIOS even when I've followed the instructions in the user's manual for X8SIT-F?

Answer: Please disable the IPMI jumper and try it again. For jumper the location, please check Chapter 1.

3-4 Battery Removal and Installation

Battery Removal

To remove the onboard battery, follow the steps below:

- 1** Power off your system and unplug your power cable.
- 2** Locate the onboard battery as shown on the right.
- 3** Using a tool such as a pen or a small screwdriver, push the battery lock outwards to unlock it.
- 4** Once unlocked, the battery will pop out from the holder.
- 5** Remove the battery.

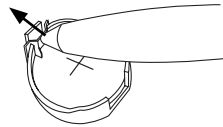
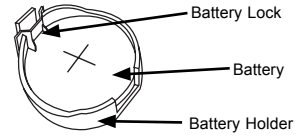

Battery Disposal: Please handle used batteries carefully. Do not damage the battery in any way; a damaged battery may release hazardous materials into the environment. Do not discard a used battery in the garbage or a public landfill. Please comply with the regulations set up by your local hazardous waste management agency to dispose of your used battery properly.

Battery Installation

To install an onboard battery, follow the steps 1~2 above and continue below:

- 1** Identify the battery's polarity. The positive (+) side should be facing up.
- 2** Insert the battery into the battery holder and push it down until you hear a click to ensure that the battery is securely locked.

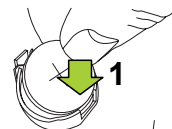
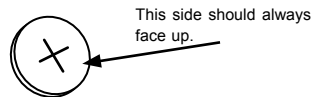

Warning: When replacing a battery, be sure to only replace it with the same type.

3-5 Returning Merchandise for Service

A receipt or copy of your invoice marked with the date of purchase is required before any warranty service will be rendered. You can obtain service by calling your vendor for a Returned Merchandise Authorization (RMA) number. (For faster service, you may also obtain RMA authorizations online (<http://www.supermicro.com/support/rma/>). When returning to the manufacturer, the RMA number should be prominently displayed on the outside of the shipping carton, and mailed prepaid or hand-carried. Shipping and handling charges will be applied for all orders that must be mailed when service is complete.

This warranty only covers normal consumer use and does not cover damages incurred in shipping or from failure due to the alteration, misuse, abuse or improper maintenance of products.

During the warranty period, contact your distributor first for any product problems.

Notes

Chapter 4

BIOS

4-1 Introduction

This chapter describes the AMI BIOS Setup Utility for the X8SIT-F. The AMI ROM BIOS is stored in a Flash EEPROM and can be easily updated. This chapter describes the basic navigation of the AMI BIOS Setup Utility setup screens.



Note: For instructions on BIOS recovery, please refer to the instruction guide posted at <http://www.supermicro.com/support/manuals/>.

Starting BIOS Setup Utility

To enter the AMI BIOS Setup Utility screens, press the <Delete> key while the system is booting up.



Note: In most cases, the <Delete> key is used to invoke the AMI BIOS setup screen. There are a few cases when other keys are used, such as <F1>, <F2>, etc.

Each main BIOS menu option is described in this manual. The Main BIOS setup menu screen has two main frames. The left frame displays all the options that can be configured. Grayed-out options cannot be configured. Options in blue can be configured by the user. The right frame displays the key legend. Above the key legend is an area reserved for a text message. When an option is selected in the left frame, it is highlighted in white. Often a text message will accompany it. (**Note:** the AMI BIOS has default text messages built in. Supermicro retains the option to include, omit, or change any of these text messages.)

The AMI BIOS Setup Utility uses a key-based navigation system called "hot keys". Most of the AMI BIOS setup utility "hot keys" can be used at any time during the setup navigation process. These keys include <F1>, <F10>, <Enter>, <ESC>, arrow keys, etc.



Note: Options printed in **Bold** are default settings.

How To Change the Configuration Data

The configuration data that determines the system parameters may be changed by entering the AMI BIOS Setup utility. This Setup utility can be accessed by pressing at the appropriate time during system boot.

How to Start the Setup Utility

Normally, the only visible Power-On Self-Test (POST) routine is the memory test. As the memory is being tested, press the <Delete> key to enter the main menu of the AMI BIOS Setup Utility. From the main menu, you can access the other setup screens. An AMI BIOS identification string is displayed at the left bottom corner of the screen, below the copyright message.



Warning! Do not upgrade the BIOS unless your system has a BIOS-related issue. Flashing the wrong BIOS can cause irreparable damage to the system. In no event shall Supermicro be liable for direct, indirect, special, incidental, or consequential damages arising from a BIOS update. If you have to update the BIOS, do not shut down or reset the system while the BIOS is updating. This is to avoid possible boot failure.

4-2 Main Setup

When you first enter the AMI BIOS Setup Utility, you will enter the Main setup screen. You can always return to the Main setup screen by selecting the Main tab on the top of the screen. The Main BIOS Setup screen is shown below.

BIOS SETUP UTILITY	
Main	Advanced Security Boot Exit
System Time	[14:41:28]
System Date	[Wed 02/03/2010]
Supermicro X8SIT (-F) Version : 1.0 Build Date : 01/28/10	
Processor Intel(R) Xeon(R) CPU X3460 @ 2.80GHz Speed : 2800MHz Physical Count : 1 Logical Count : 8	
System Memory Populated Size : 16384MB	
Use [ENTER], [TAB] or [SHIFT-TAB] to select a field. Use [+] or [-] to configure system Time. ↑↔: Move Enter: Select +/-: Value F10: Save ESC: Exit F1: General Help F8: Fail-Safe Defaults F9: Optimized Defaults	
v02.67 (C) Copyright 1985-2009, American Megatrends, Inc.	

System Overview: The following BIOS information will be displayed:

System Time/System Date

Use this option to change the system time and date. Highlight *System Time* or *System Date* using the arrow keys. Enter new values through the keyboard. Press the <Tab> key or the arrow keys to move between fields. The date must be entered in Day MM/DD/YY format. The time is entered in HH:MM:SS format. (**Note:** The time is in the 24-hour format. For example, 5:30 P.M. appears as 17:30:00.)

Supermicro X8SIT-F

Version

Build Date

Processor

The AMI BIOS will automatically display the status of processor as shown below:

Type of Processor

Speed

Physical Count

Logical Count

System Memory

This displays the size of memory available in the system:

Populated Size

4-3 Advanced Setup Configurations

Use the arrow keys to select Boot Setup and hit <Enter> to access the submenu items:



► BOOT Feature

Quick Boot

If Enabled, this option will skip certain tests during POST to reduce the time needed for system boot. The options are **Enabled** and Disabled.

Quiet Boot

This option allows the bootup screen options to be modified between POST messages or the OEM logo. Select Disabled to display the POST messages. Select Enabled to display the OEM logo instead of the normal POST messages. The options are **Enabled** and Disabled.

AddOn ROM Display Mode

This sets the display mode for Option ROM. The options are **Force BIOS** and Keep Current.

Bootup Num-Lock

This feature selects the Power-on state for Numlock key. The options are Off and **On**.

Wait For 'F1' If Error

This forces the system to wait until the 'F1' key is pressed if an error occurs. The options are Disabled and **Enabled**.

Hit 'Del' Message Display

This feature displays "Press DEL to run Setup" during POST. The options are **Enabled** and Disabled.

Watch Dog Function

If enabled, the Watch Dog Timer will allow the system to reboot when it is inactive for more than 5 minutes. The options are Enabled and **Disabled**.

Power Button Mode

This setting allows you to decide if the power button will turn off the system instantly or wait for 4 seconds when it is pressed. The options are **Instant Off** and 4 Seconds Override.

Restore on AC Power Loss

Use this feature to set the power state after a power outage. Select Power-Off for the system power to remain off after a power loss. Select Power-On for the system power to be turned on after a power loss. Select Last State to allow the system to resume its last state before a power loss. The options are Power-On, Power-Off and **Last State**.

Interrupt 19 Capture

Interrupt 19 is the software interrupt that handles the boot disk function. When this item is set to Enabled, the ROM BIOS of the host adaptors will "capture" Interrupt 19 at boot and allow the drives that are attached to these host adaptors to function as bootable disks. If this item is set to Disabled, the ROM BIOS of the host adaptors will not capture Interrupt 19, and the drives attached to these adaptors will not function as bootable devices. The options are **Enabled** and Disabled.

SMC Chassis Type

This feature selects the type of Supermicro chassis used with the motherboard. Select 1U for the Twin system, which features a Power Fail LED and an Overheat (OH)/Fan Fail LED. Select 2U for the Twin2 system, which features a System Warning LED only. The options are **1U** and 2U.

►Processor & Clock Options



Warning: Take Caution when changing the Advanced settings. An incorrect value, a very high DRAM frequency or incorrect DRAM timing may cause system to become unstable. When this occurs, revert to the default setting.

CPU Ratio

This feature allows the user to use the CPU clock multiplier to multiply CPU speed in order to enhance performance. Select Manual to Manually set the multiplier setting. Select Auto for the BIOS to automatically select the CPU multiplier setting for your system. The options are **Auto** and Manual.

Clock Spread Spectrum

Select Enable to use the feature of Clock Spectrum, which will allow the BIOS to monitor and attempt to reduce the level of Electromagnetic Interference caused by the components whenever needed. Select Disabled to enhance system stability. The options are **Disabled** and Enabled.

Hardware Prefetcher (Available when supported by the CPU)

If set to Enabled, the hardware pre fetcher will pre fetch streams of data and instructions from the main memory to the L2 cache in the forward or backward manner to improve CPU performance. The options are Disabled and **Enabled**.

Adjacent Cache Line Prefetch (Available when supported by the CPU)

The CPU fetches the cache line for 64 bytes if this option is set to Disabled. The CPU fetches both cache lines for 128 bytes as comprised if **Enabled**.

MPS and ACPI MADT Ordering

This feature allows the user to choose the method of ordering for the Multiple APIC Description Table (MADT). Select Modern Ordering if you have the Microsoft Windows XP or later version of the OS. Select Legacy Ordering if you use Microsoft Windows 2000 or earlier version of the OS. The options are **Modern Ordering** and Legacy Ordering.

Intel® Virtualization Technology (Available when supported by the CPU)

Select Enabled to use the feature of Virtualization Technology to allow one platform to run multiple operating systems and applications in independent partitions, creating multiple "virtual" systems in one physical computer. The options are **Enabled** and Disabled. **Note:** If there is any change to this setting, you will need to power off and restart the system for the change to take effect. Please refer to Intel's web site for detailed information.

Execute-Disable Bit Capability (Available when supported by the OS and the CPU)

Set to Enabled to enable the Execute Disable Bit which will allow the processor to designate areas in the system memory where an application code can execute and where it cannot, thus preventing a worm or a virus from flooding illegal codes to overwhelm the processor or damage the system during an attack. The default is **Enabled**. (Refer to Intel and Microsoft Web Sites for more information.)

Simultaneous Multi-Threading (Available when supported by the CPU)

Set to Enabled to use the Hyper-Threading Technology, which will result in increased CPU performance. The options are Disabled and **Enabled**.

Active Processor Cores

Set to Enabled to use a processor's Second Core and beyond. (Please refer to Intel's web site for more information.) The options are **All**, 1, 2, 3 and 4.

Intel® EIST Technology

EIST (Enhanced Intel SpeedStep Technology) allows the system to automatically adjust processor voltage and core frequency in an effort to reduce power consumption and heat dissipation. **Please refer to Intel's web site for detailed information.** The options are Disabled and **Enabled**.

Intel® Turbo Boost Technology (Available if Intel® EIST technology is Enabled)

This feature allows processor cores to run faster than marked frequency in specific conditions. The options are Disabled and **Enabled**.

C1E Support

Select Enabled to use the "Enhanced Halt State" feature. C1E significantly reduces the CPU's power consumption by reducing the CPU's clock cycle and voltage during a "Halt State." The options are Disabled and **Enabled**.

Intel® C-STATE Tech

If enabled, C-State is set by the system automatically to either C2, C3 or C4 state. The options are Default and **Enabled**.

C-State package limit setting

If set to Auto, the AMI BIOS will automatically set the limit on the C-State package register. The options are **Auto**, C1, C3, C6 and C7.

C1 Auto Demotion

When enabled, the CPU will conditionally demote C3, C6 or C7 requests to C1 based on un-core auto-demote information. The options are Disabled and **Enabled**.

C3 Auto Demotion

When enabled, the CPU will conditionally demote C6 or C7 requests to C3 based on un-core auto-demote information. The options are Disabled and **Enabled**.

►Advanced Chipset Control

The items included in the Advanced Settings submenu are listed below.

Memory Remap Feature

This feature, when enabled, allows the remapping of overlapped PCI memory above the total physical memory. The settings are **Enabled** and Disabled.

Intel VT-d

Select Enabled to enable Intel's Virtualization Technology support for Direct I/O VT-d by reporting the I/O device assignments to VMM through the DMAR ACPI Tables. This feature offers fully-protected I/O resource-sharing across the Intel platforms, providing the user with greater reliability, security and availability in networking and data-sharing. The settings are Enabled and **Disabled**.

Active State Power Management

Select Enabled to start Active-State Power Management for signal transactions between L0 and L1 Links on the PCI Express Bus. This maximizes power-saving and transaction speed. The options are Enabled and **Disabled**.

USB Functions

This feature allows the user to decide the number of onboard USB ports to be enabled. The Options are: Disabled and **Enabled**.

Legacy USB Support (available if USB Functions above is Enabled)

Select Enabled to use Legacy USB devices. If this item is set to Auto, Legacy USB support will be automatically enabled if a legacy USB device is installed on the motherboard, and vice versa. The settings are Disabled, Enabled and **Auto**.

►SATA Configuration

When this submenu is selected, the AMI BIOS automatically detects the presence of the IDE Devices and displays the following items:

SATA#1 Configuration

If Compatible is selected, it sets SATA#1 to legacy compatibility mode, while selecting Enhanced sets SATA#1 to native SATA mode. The options are Disabled, Compatible, **Enhanced**.

Configure SATA as

This feature allows the user to select the drive type for SATA#1. The options are **IDE**, **RAID** and **AHCI**.

PCH RAID CodeBase (Available if RAID is selected above)

Select Intel to enable the Intel SATA Host RAID Utility. Select Adaptec to use the Adaptec Host RAID Utility. The options are **Intel** and **Adaptec**.

SATA#2 Configuration (Available when IDE is enabled under "Configure SATA#1 as" above)

Selecting Enhanced will set SATA#2 to native SATA mode. The options are **Disabled** and **Enhanced**

IDE Detect Timeout (sec)

Use this feature to set the time-out value for the BIOS to detect the ATA, ATAPI devices installed in the system. The options are 0 (sec), 5, 10, 15, 20, 25, 30, and **35**.

SATA 0 ~ 5

These settings allow the user to set the parameters of the disc storage devices attached to the SATA ports. Press <Enter> to activate the following submenu screen for detailed options of these items. Set the correct configurations accordingly. The items included in the submenu are:

Type

Select the type of device connected to the system. The options are **Not Installed**, **Auto**, **CD/DVD** and **ARMD**.

LBA/Large Mode

LBA (Logical Block Addressing) is a method of addressing data on a disk drive. In the LBA mode, the maximum drive capacity is 137 GB. For drive capacities over 137 GB, your system must be equipped with a 48-bit LBA mode addressing. If not, contact your manufacturer or install an ATA/133 IDE controller card that supports 48-bit LBA mode. The options are **Disabled** and **Auto**.

Block (Multi-Sector Transfer)

Block Mode boosts the IDE drive performance by increasing the amount of data transferred. Only 512 bytes of data can be transferred per interrupt if Block Mode is not used. Block Mode allows transfers of up to 64 KB per interrupt. Select **Disabled** to allow data to be transferred from and to the device one sector at a time. Select **Auto** to allow data transfer from and to the device occur multiple sectors at a time if the device supports it. The options are **Auto** and **Disabled**.

PIO Mode

The IDE PIO (Programmable I/O) Mode programs timing cycles between the IDE drive and the programmable IDE controller. As the PIO mode increases, the cycle time decreases. The options are **Auto**, 0, 1, 2, 3, and 4.

Select Auto to allow the AMI BIOS to automatically detect the PIO mode. Use this value if the IDE disk drive support cannot be determined.

Select 0 to allow the AMI BIOS to use PIO mode 0. It has a data transfer rate of 3.3 MBs.

Select 1 to allow the AMI BIOS to use PIO mode 1. It has a data transfer rate of 5.2 MBs.

Select 2 to allow the AMI BIOS to use PIO mode 2. It has a data transfer rate of 8.3 MBs.

Select 3 to allow the AMI BIOS to use PIO mode 3. It has a data transfer rate of 11.1 MBs.

Select 4 to allow the AMI BIOS to use PIO mode 4. It has a data transfer bandwidth of 32-Bits. Select Enabled to enable 32-Bit data transfer.

DMA Mode

Select Auto to allow the BIOS to automatically detect IDE DMA mode when the IDE disk drive support cannot be determined.

Select SWDMA0 to allow the BIOS to use Single Word DMA mode 0. It has a data transfer rate of 2.1 MBs.

Select SWDMA1 to allow the BIOS to use Single Word DMA mode 1. It has a data transfer rate of 4.2 MBs.

Select SWDMA2 to allow the BIOS to use Single Word DMA mode 2. It has a data transfer rate of 8.3 MBs.

Select MWDMA0 to allow the BIOS to use Multi Word DMA mode 0. It has a data transfer rate of 4.2 MBs.

Select MWDMA1 to allow the BIOS to use Multi Word DMA mode 1. It has a data transfer rate of 13.3 MBs.

Select MWDMA2 to allow the BIOS to use Multi-Word DMA mode 2. It has a data transfer rate of 16.6 MBs.

Select UDMA0 to allow the BIOS to use Ultra DMA mode 0. It has a data transfer rate of 16.6 MBs. It has the same transfer rate as PIO mode 4 and Multi Word DMA mode 2.

Select UDMA1 to allow the BIOS to use Ultra DMA mode 1. It has a data transfer rate of 25 MBs.

Select UDMA2 to allow the BIOS to use Ultra DMA mode 2. It has a data transfer rate of 33.3 MBs.

Select UDMA3 to allow the BIOS to use Ultra DMA mode 3. It has a data transfer rate of 66.6 MBs.

Select UDMA4 to allow the BIOS to use Ultra DMA mode 4 . It has a data transfer rate of 100 MBs.

The options are **Auto**, SWDMAn, MWDMAAn, and UDMAAn.

S.M.A.R.T.

Self-Monitoring Analysis and Reporting Technology (SMART) can help predict impending drive failures. Select Auto to allow the AMI BIOS to automatically detect hard disk drive support. Select Disabled to prevent the AMI BIOS from using the S.M.A.R.T. Select Enabled to allow the AMI BIOS to use the S.M.A.R.T. to support hard drive disk. The options are Disabled, Enabled, and **Auto**.

32-Bit Data Transfer

Select Enable to enable the function of 32-bit IDE data transfer. The options are **Enabled** and Disabled.

► PCI/PnP Configuration

This feature allows the user to set the PCI/PnP configurations for the following items:

Clear NVRAM

This feature clears the NVRAM during system boot. The options are **No** and Yes.

Plug & Play OS

Selecting Yes allows the OS to configure Plug & Play devices. (This is not required for system boot if your system has an OS that supports Plug & Play.) Select **No** to allow the AMI BIOS to configure all devices in the system.

PCI Latency Timer

This feature sets the latency Timer of each PCI device installed on a PCI bus. Select 64 to set the PCI latency to 64 PCI clock cycles. The options are 32, **64**, 96, 128, 160, 192, 224 and 248.

PCI IDE Bus Master

When enabled, the BIOS uses PCI bus mastering for reading/writing to IDE drives. The options are **Disabled** and Default.

PCIe I/O Performance

This feature selects the setting for the processor's PCIe maximum payload size. The options are 128B and **256B**.

ROM Scan Ordering

This item determines what kind of option ROM activates over another. The options are **Onboard First** and Add-on First.

PCI Slot 1 OPROM

Use this feature to enable or disable PCI slot Option ROMs. The options are Disabled and **Enabled**.

Onboard LAN1 Option ROM Select

This feature selects whether to load the iSCSI or PXE onboard LAN option ROM. The options are iSCSI and **PXE**.

Load Onboard LAN1 Option ROM**Load Onboard LAN2 Option ROM**

This feature is to enable or disable the onboard LAN option ROMs. The options are **Disabled** and Enabled.

Boot Graphics Adapter Priority

Use this feature to select the graphics controller to be used as the primary boot device. The options are Other and **Onboard VGA**.

► Super IO Device Configuration**Serial Port1 Address/ Serial Port3 Address**

This option specifies the base I/O port address and the Interrupt Request address of Serial Port 1 and Serial Port 3. Select Disabled to prevent the serial port from accessing any system resources. When this option is set to Disabled, the serial port physically becomes unavailable. Select 3F8/IRQ4 to allow the serial port to use 3F8 as its I/O port address and IRQ 4 for the interrupt address. The options for Serial Port 1 are Disabled, **3F8/IRQ4**, 2E8/IRQ3. The options for Serial Port 3 are Disabled, **2F8/IRQ3**, and 2E8/IRQ3.

► Remote Access Configuration**Remote Access**

This allows the user to enable the Remote Access feature. The options are **Disabled** and Enabled.

If Remote Access is set to Enabled, the following items will display:

Serial Port Number

This feature allows the user to decide which serial port to be used for Console Redirection. The options are COM 1 and **COM 3**.

Note: Serial Over LAN (SOL) will be enabled when either COM 1 or COM 3 is selected.

Serial Port Mode

This feature allows the user to set the serial port mode for Console Redirection. The options are **115200 8, n 1**; 57600 8, n, 1; 38400 8, n, 1; 19200 8, n, 1; and 9600 8, n, 1.

Flow Control

This feature allows the user to set the flow control for Console Redirection. The options are **None**, Hardware, and Software.

Redirection After BIOS POST

Select Disabled to turn off Console Redirection after Power-On Self-Test (POST). Select Always to keep Console Redirection active all the time after POST. (Note: This setting may not be supported by some operating systems.) Select Boot Loader to keep Console Redirection active during POST and Boot Loader. The options are Disabled, Boot Loader, and **Always**.

Terminal Type

This feature allows the user to select the target terminal type for Console Redirection. The options are **ANSI**, VT100, and VT-UTF8.

VT-UTF8 Combo Key Support

This is a terminal keyboard definition that provides a way to send commands from a remote console. Available options are **Enabled** and Disabled.

Sredir Memory Display Delay

This feature defines the length of time in seconds to display memory information. The options are **No Delay**, Delay 1 Sec, Delay 2 Sec, and Delay 4 Sec.

► Hardware Health Configuration

This feature allows the user to monitor Hardware Health of the system and review the status of each item when displayed.

CPU Overheat Alarm

This option allows the user to select the CPU Overheat Alarm setting which determines when the CPU OH alarm will be activated to provide warning of possible CPU overheat.



Warning: Any temperature that exceeds the CPU threshold temperature predefined by the CPU manufacturer may result in CPU overheat or system instability. When the CPU temperature reaches this predefined threshold, the CPU and system cooling fans will run at full speed.

The options are:

- The Early Alarm: Select this setting if you want the CPU overheat alarm (including the LED and the buzzer) to be triggered as soon as the CPU temperature reaches the CPU overheat threshold as predefined by the CPU manufacturer.
- **The Default Alarm:** Select this setting if you want the CPU overheat alarm (including the LED and the buzzer) to be triggered when the CPU temperature reaches about 5°C above the threshold temperature as predefined by the CPU manufacturer to give the CPU and system fans additional time needed for CPU and system cooling. In both the alarms above, please take immediate action as shown below.

System Temperature

This feature displays the absolute system temperature (i.e., 34°C).

CPU Temperature

The CPU Temperature feature will display the CPU temperature status as detected by the BIOS:

Low – This level is considered as the ‘normal’ operating state. The CPU temperature is well below the CPU ‘Temperature Tolerance’. The motherboard fans and CPU will run normally as configured in the BIOS (Fan Speed Control).

User intervention: No action required.

Medium – The processor is running warmer. This is a ‘precautionary’ level and generally means that there may be factors contributing to this condition, but the CPU is still within its normal operating state and below the CPU ‘Temperature Tolerance’. The motherboard fans and CPU will run normally as configured in the BIOS. The fans may adjust to a faster speed depending on the Fan Speed Control settings.

User intervention: No action is required. However, consider checking the CPU fans and the chassis ventilation for blockage.

High – The processor is running hot. This is a ‘caution’ level since the CPU’s ‘Temperature Tolerance’ has been reached (or has been exceeded) and may activate an overheat alarm:

The Default Alarm – the Overheat LED and system buzzer will activate if the High condition continues for some time after it is reached. The CPU fan will run at full speed to bring the CPU temperature down. If the CPU temperature still increases

even with the CPU fan running at full speed, the system buzzer will activate and the Overheat LED will turn on.

The Early Alarm – the Overheat LED and system buzzer will be activated exactly when the High level is reached. The CPU fan will run at full speed to bring the CPU temperature down.

Note: In both the alarms above, please take immediate action as shown below. See CPU Overheat Alarm to modify the above alarm settings.

User intervention: If the system buzzer and Overheat LED has activated, take action immediately by checking the system fans, chassis ventilation and room temperature to correct any problems. **Note:** the system may shut down if it continues for a long period to prevent damage to the CPU.



Notes: The CPU thermal technology that reports absolute temperatures (Celsius/Fahrenheit) has been upgraded to a more advanced feature by Intel in its newer processors. The basic concept is that each CPU is embedded by a unique temperature information that the motherboard can read. This 'Temperature Threshold' or 'Temperature Tolerance' has been assigned at the factory and is the baseline by which the motherboard takes action during different CPU temperature conditions (i.e., by increasing CPU Fan speed, triggering the Overheat Alarm, etc). Since CPUs can have different 'Temperature Tolerances', the installed CPU can now send its 'Temperature Tolerance' to the motherboard resulting in better CPU thermal management.

Supermicro has leveraged this feature by assigning a temperature status to certain thermal conditions in the processor (Low, Medium and High). This makes it easier for the user to understand the CPU's temperature status, rather than by just simply seeing a temperature reading (i.e., 25°C).

The information provided above is for your reference only. For more information on thermal management, please refer to Intel's Web site at www.Intel.com.

Fan1 ~ Fan 4 Reading

This feature displays the fan speed readings from fan interfaces Fan1 through Fan4.

Fan Speed Control Modes

This feature allows the user to decide how the system controls the speeds of the onboard fans. The CPU temperature and the fan speed are correlative. When the CPU on-die temperature increases, the fan speed will also increase for effective system cooling. Select Full Speed to allow the onboard fans to run at full speed (of 100% Pulse Width Modulation Duty Cycle) for maximum cooling. The Full Speed setting is recommended for special system configuration or debugging. Select Performance for the onboard fans to run at 70% of the Initial PWM Cycle for

better system cooling. The Performance setting is recommended for high-power-consuming and high-density systems. Select Balanced for the onboard fans to run at 50% of the Initial PWM Cycle in order to balance the needs between system cooling and power saving. The Balanced setting is recommended for regular systems with normal hardware configurations. Select Energy Saving for the onboard fans to run at 30% of the Initial PWM Cycle for best power efficiency and maximum quietness. The Options are: **Full Speed (@100% of PWM Cycle)**, Performance (@70% of PWM Cycle), Balanced (@50% of PWM Cycle), and Energy Saving (@30% of PWM Cycle).

CPU Vcore, AVCC, 3.3Vcc, 12V, V_DIMM, 5V, 5Vsb, 3.3Vsb, and Vbat

►ACPI Configuration

Use this feature to configure Advanced Configuration and Power Interface (ACPI) power management settings for your system.

High Performance Event Timer

Select Enabled to activate the High Performance Event Timer (HPET) that produces periodic interrupts at a much higher frequency than a Real-time Clock (RTC) does in synchronizing multimedia streams, providing smooth playback and reducing the dependency on other timestamp calculation devices, such as an x86 RDTSC Instruction embedded in the CPU. The High Performance Event Timer is used to replace the 8254 Programmable Interval Timer. The options are **Enabled** and Disabled.

ACPI Aware O/S

Enable ACPI support if it is supported by the OS to control ACPI through the Operating System. Otherwise, disable this feature. The options are **Yes** and **No**.

ACPI APIC Support

Select Enabled to include the ACPI APIC Table Pointer in the RSDT (Root System Description Table) pointer list. The options are **Enabled** and Disabled.

APIC ACPI SCI IRQ

When this item is set to Enabled, APIC ACPI SCI IRQ is supported by the system. The options are Enabled and **Disabled**.

Headless Mode

This feature is used to enable the system to function without a keyboard, monitor or mouse attached. The options are Enabled and **Disabled**.

ACPI Version Features

The options are ACPI v1.0, **ACPI v2.0** and ACPI v3.0. Please refer to ACPI's website for further explanation: <http://www.acpi.info/>

►IPMI Configuration

Intelligent Platform Management Interface (IPMI) is a set of common interfaces that IT administrators can use to monitor system health and to manage the system as a whole. For more information on the IPMI specifications, please visit Intel's website at www.intel.com.

IPMI Firmware Revision

This item displays the current IPMI firmware revision.

Status of BMC

Baseboard Management Controller (BMC) manages the interface between system management software and platform hardware. This is an informational feature which returns the status code of the BMC micro controller.

View BMC System Event Log

This feature is used to view any BMC events. It shows the total number of entries and will allow the viewing of each event by scrolling down on an Entry Number and pressing Enter.

Clear BMC System Event Log

This feature is used to clear the System Event Log. Caution: Any cleared information is unrecoverable. Make absolutely sure you no longer need any data stored in the log before clearing the BMC Event Log.

Set LAN Configuration

Set this feature to configure the IPMI LAN adapter with a network address.

Channel Number - Enter the channel number for the SET LAN Config command. This is initially set to **[1]**. Press <+> or <-> on your keyboard to change the Channel Number.

Channel Number Status - This feature returns the channel status for the Channel Number selected above: "Channel Number is OK" or "Wrong Channel Number".

IP Address Source - This feature selects whether the IP address, Subnet Mask and Gateway Address are automatically assigned by the network's DHCP server (Dynamic Host and Configuration Protocol) or manually entered by the user (Static). If Static is selected, the IP Address, Subnet Mask and Gateway

Address must be manually entered below. If DHCP is selected, the next three items will be configured automatically and will be grayed out. The options are Static and **DHCP**.

IP Address - Enter the IP address for this machine. This should be in decimal and in dotted quad form (i.e., 192.168.10.253). The value of each three-digit number separated by dots should not exceed 255.

Subnet Mask - Subnet masks tell the network which subnet the machine belongs to. The value of each three-digit number separated by dots should not exceed 255 (i.e., 255.255.255.0).

Gateway Address - Enter the IP address of the Gateway this machine will use (i.e., 192.168.10.1).

MAC Address - The BIOS will automatically enter the MAC address (also known as Hardware Address) of this machine, however it may be over-ridden. MAC addresses are 6 two-digit hexadecimal numbers (Base 16, 0 ~ 9, A, B, C, D, E, F) separated by dots. (i.e., 00.30.48.9E.73.CF)

BMC Watch Dog Timer Action

This feature allows the BMC to reset or power down the system if the operating system hangs or crashes. The options are **Disabled**, Reset System, Power Down, Power Cycle.

BMC WatchDog TimeOut [Min:Sec]

This option appears if BMC Watch Dog Timer Action (above) is enabled. This is a timed delay in minutes or seconds, before a system power down or reset after an operating system failure is detected. The options are **[5 Min]**, [1 Min], [30 Sec], and [10 Sec].

►Event Log Configuration

View Event Log

Use this option to view the System Event Log.

Mark all events as read

This option marks all events as read. The options are OK and Cancel.

Clear event log

This option clears the Event Log memory of all messages. The options are OK and **Cancel**.

PCIe Error Log

Use this option to enable logging of errors encountered in the system's PCIe bus. The options are Yes and **No**.

4-4 Security Settings

The AMI BIOS provides a Supervisor and a User password. If you use both passwords, the Supervisor password must be set first.



Supervisor Password

This item indicates if a supervisor password has been entered for the system. Clear means such a password has not been used and Set means a supervisor password has been entered for the system.

User Password:

This item indicates if a user password has been entered for the system. Clear means such a password has not been used and Set means a user password has been entered for the system.

Change Supervisor Password

Select this feature and press <Enter> to access the submenu, and then type in a new Supervisor Password.

User Access Level (Available when Supervisor Password is set as above)

Available options are **Full Access**: grants full User read and write access to the Setup Utility, **View Only**: allows access to the Setup Utility but the fields cannot be changed, **Limited**: allows only limited fields to be changed such as Date and Time, **No Access**: prevents User access to the Setup Utility.

Change User Password

Select this feature and press <Enter> to access the submenu, and then type in a new User Password.

Clear User Password (Available only if User Password has been set)**Password Check**

Available options are **Setup** and Always.

Boot Sector Virus Protection

When Enabled, the AMI BOIS displays a warning when any program (or virus) issues a Disk Format command or attempts to write to the boot sector of the hard disk drive. The options are Enabled and **Disabled**.

4-5 Boot Settings

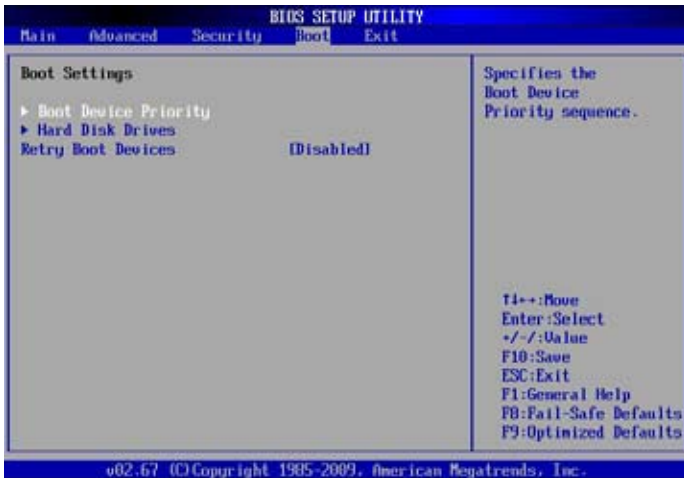

Use this feature to configure Boot Settings:

► Boot Device Priority

This feature allows the user to specify the sequence of priority for the Boot Device. The settings are 1st boot device, 2nd boot device, 3rd boot device, 4th boot device, 5th boot device and Disabled.

- 1st Boot Device - 1st Floppy Drive
- 2nd Boot Device - [USB: XXXXXXXXX]
- 3rd Boot Device - [SATA: XXXXXXXXX]
- 4th Boot Device - [Network: XXXXXXXXX]
- 5th Boot Device - [Network: XXXXXXXXX]

► Hard Disk Drives

This feature allows the user to specify the sequence of priority from the available Hard Drives.

- 1st Drive [SATA: XXXXXXXXXXXX]
- 2nd Drive [SATA: XXXXXXXXXXXX]

► Removable Drives

This feature allows the user to specify the boot sequence from available Removable Drives. The settings are 1st boot device, 2nd boot device, and Disabled.

- 1st Drive
- 2nd Drive - [USB: XXXXXXXXXXXX]

Retry Boot Devices

Select this option to retry booting from the configured boot devices if the systems fail to boot initially. The options are **Disabled** and Enabled.

4-6 Exit Options

Select the Exit tab from the AMI BIOS Setup Utility screen to enter the Exit BIOS Setup screen.



Save Changes and Exit

When you have completed the system configuration changes, select this option to leave the BIOS Setup Utility and reboot the computer, so the new system configuration parameters can take effect. Select Save Changes and Exit from the Exit menu and press <Enter>.

Discard Changes and Exit

Select this option to quit the BIOS Setup without making any permanent changes to the system configuration, and reboot the computer. Select Discard Changes and Exit from the Exit menu and press <Enter>.

Discard Changes

Select this option and press <Enter> to discard all the changes and return to the AMI BIOS Utility Program.

Load Optimal Defaults

To set this feature, select Load Optimal Defaults from the Exit menu and press <Enter>. Then, select OK to allow the AMI BIOS to automatically load Optimal Defaults to the BIOS Settings. The Optimal settings are designed for maximum system performance, but may not work best for all computer applications.

Load Fail-Safe Defaults

To set this feature, select Load Fail-Safe Defaults from the Exit menu and press <Enter>. The Fail-Safe settings are designed for maximum system stability, but not for maximum performance.

Notes

Appendix A

POST Error Beep Codes

This section lists POST (Power On Self Test) error beep codes for the AMI BIOS. POST error beep codes are divided into two categories: recoverable and terminal. This section lists Beep Codes for recoverable POST errors.

Recoverable POST Error Beep Codes

When a recoverable type of error occurs during POST, BIOS will display a POST code that describes the problem. BIOS may also issue one of the following beep codes:

- 1 long and eight short beeps - video configuration error
- 1 repetitive long beep - no memory detected
- 1 continuous beep with the front panel Overheat LED on - system overheat

Notes

Appendix B

Software Installation Instructions

B-1 Installing Drivers

After you've installed the Windows Operating System, a screen as shown below will appear. You are ready to install software programs and drivers that have not yet been installed. To install these software programs and drivers, click the icons to the right of these items. (**Note:** To install the Windows Operating System, please refer to the instructions posted on our website at <http://www.supermicro.com/support/manuals/>.)



Driver/Tool Installation Display Screen



Note: Click the icons showing a hand writing on the paper to view the readme files for each item. Click a computer icon to the right of an item to install an item (from top to the bottom) one at a time. After installing each item, you must re-boot the system before proceeding with the next item on the list. The bottom icon with a CD on it allows you to view the entire contents of the CD.

B-2 Configuring Supero Doctor III

The Supero Doctor III program is a Web-based management tool that supports remote management capability. It includes Remote and Local Management tools. The local management is called the SD III Client. The Supero Doctor III program included on the CDROM that came with your motherboard allows you to monitor the environment and operations of your system. Supero Doctor III displays crucial system information such as CPU temperature, system voltages and fan status. See the Figure below for a display of the Supero Doctor III interface.



Note 1: Both default user name and password are ADMIN.

Note 2: In the Windows OS environment, the Supero Doctor III settings take precedence over the BIOS settings. When first installed, Supero Doctor III adopts the temperature threshold settings previously set in the BIOS. Any subsequent changes to these thresholds must be made within Supero Doctor, since the SD III settings override the BIOS settings. For the Windows OS to adopt the BIOS temperature threshold settings, please change the SDIII settings to be the same as those set in the BIOS.

Supero Doctor III Interface Display Screen-I (Health Information)



Supero Doctor III Interface Display Screen-II (Remote Control)

Note: SD III Software Revision 1.0 can be downloaded from our Web site at: ftp://ftp.supermicro.com/utility/Supero_Doctor_III/. You can also download SDIII User's Guide at: <http://www.supermicro.com/PRODUCT/Manuals/SDIII/UserGuide.pdf>. For Linux, we will still recommend that you use Supero Doctor II.

Notes

Appendix C - BIOS Recovery

The recovery procedure described in this section is to be used only when you are advised by your Supermicro Technical Support representative, or in cases of emergencies where the system can no longer boot due to a corrupted BIOS. DO NOT re-program (re-flash) the BIOS if your system is running properly.

C-1 Recovery Process from a USB Device/Drive (Recommended Method)

If the BIOS file is corrupted, and the system is not able to boot up, this feature will allow you to recover the BIOS image using a USB-attached device. A USB Flash Drive or a USB CD/DVD ROM/RW drive may be used for this purpose. Please note that a USB Hard Disk drive is NOT supported at this time. Below is a two-part procedure to recover the BIOS:

Part 1: Boot Sector Recovery Process

1. Using a different system, download and copy the correct BIOS binary image into a USB flash device or a writable CD/DVD disc's Root "" Directory. Rename the downloaded file to "super.rom", so the recovery process can recognize and read the BIOS binary file.
2. Insert the USB device that contains the new BIOS binary image ("super.rom") and power the system down.
3. While powering on the system, press and hold <Ctrl> and <Home> simultaneously on your keyboard until the USB device's LED indicator comes on. This will take a few seconds or up to one minute.
4. Once the USB device's LED is on, release the <Ctrl> and <Home> keys. The system may generate beep codes to indicate that the BIOS ROM firmware is being reprogrammed. The screen will also display a message as shown below. DO NOT INTERRUPT THIS PROCESS!

```
Starting FLASH Recovery.
NVRAM data will be destroyed.
CMOS data will be destroyed.
.....
.....
Ending FLASH Recovery.
FLASH Update completed successfully.
Rebooting...
```

5. When the Boot Sector Recovery Process is complete, the system will reboot automatically and you will see a checksum error on your screen.

Part 2: BIOS Reprogramming (Re-Flashing)

After completing the Boot Sector Recovery Process, you will need to reprogram ("re-flash") the proper BIOS binary file again into the BIOS ROM in order to have the correct BIOS file loaded by the system. For details on how to flash/re-flash a BIOS, please check our website for "Update your BIOS", or see the section 3-3 (FAQ) of this manual. **DO NOT INTERRUPT THIS PROCESS!**

When completed, the system will reboot automatically, and you will see a checksum error again.

Press "F1" to go to setup. Press "F9" to load the defaults and then press "F10" to save and exit.

C-2 Recovery Process from an IDE/SATA ATAPI Disc Drive

This process is identical to the Boot Sector Recovery Process from a USB Device/Drive (as above), except that the BIOS image file ("super.rom") is loaded from an IDE/ATAPI CD/DVD-ROM/RW disc drive that is attached to the system. Note that loading from an IDE/SATA hard disk drive is NOT supported.

1. Using a different system, download and copy the correct BIOS binary image into a writable CD/DVD disc's Root "\\" Directory. Rename the downloaded file to "super.rom", so the recovery process can recognize and read the BIOS binary file.



Note: Record/Burn the CD/DVD-R/RW disc using the ISO 9600 standard format. Refer to your CD/DVD mastering application documentation for instructions on how to do this.

2. Insert the newly-created disc into the IDE/SATA ATAPI CD/DVD ROM/RW drive of the system that has the corrupted BIOS and power the system down.
3. Follow the step-by-step instructions under Part 1 - Recovery Process from a USB Device/Drive (above) starting from Step 3 and continue on to Part 2 - BIOS Reprogramming (Re-Flashing).

If your system still does not boot up after performing the above procedure, then there may be other issues with your motherboard. Please contact your customer service representative.

(Disclaimer Continued)

The products sold by Supermicro are not intended for and will not be used in life support systems, medical equipment, nuclear facilities or systems, aircraft, aircraft devices, aircraft/emergency communication devices or other critical systems whose failure to perform be reasonably expected to result in significant injury or loss of life or catastrophic property damage. Accordingly, Supermicro disclaims any and all liability, and should buyer use or sell such products for use in such ultra-hazardous applications, it does so entirely at its own risk. Furthermore, buyer agrees to fully indemnify, defend and hold Supermicro harmless for and against any and all claims, demands, actions, litigation, and proceedings of any kind arising out of or related to such ultra-hazardous use or sale.