

SUPER●[®]

SUPER●[®]X8QB6-LF

SUPER●[®]X8QBE-LF

USER'S MANUAL

Revision 1.0

The information in this User's Manual has been carefully reviewed and is believed to be accurate. The vendor assumes no responsibility for any inaccuracies that may be contained in this document, and makes no commitment to update or to keep current the information in this manual, or to notify any person or organization of the updates. **Please Note: For the most up-to-date version of this manual, please see our Website at www.supermicro.com.**

Super Micro Computer, Inc. ("Supermicro") reserves the right to make changes to the product described in this manual at any time and without notice. This product, including software and documentation, is the property of Supermicro and/or its licensors, and is supplied only under a license. Any use or reproduction of this product is not allowed, except as expressly permitted by the terms of said license.

IN NO EVENT WILL SUPER MICRO COMPUTER, INC. BE LIABLE FOR DIRECT, INDIRECT, SPECIAL, INCIDENTAL, SPECULATIVE OR CONSEQUENTIAL DAMAGES ARISING FROM THE USE OR INABILITY TO USE THIS PRODUCT OR DOCUMENTATION, EVEN IF ADVISED OF THE POSSIBILITY OF SUCH DAMAGES. IN PARTICULAR, SUPER MICRO COMPUTER, INC. SHALL NOT HAVE LIABILITY FOR ANY HARDWARE, SOFTWARE, OR DATA STORED OR USED WITH THE PRODUCT, INCLUDING THE COSTS OF REPAIRING, REPLACING, INTEGRATING, INSTALLING OR RECOVERING SUCH HARDWARE, SOFTWARE, OR DATA.

Any disputes arising between the manufacturer and the customer shall be governed by the laws of Santa Clara County in the State of California, USA. The State of California, County of Santa Clara shall be the exclusive venue for the resolution of any such disputes. Supermicro's total liability for all claims will not exceed the price paid for the hardware product.

FCC Statement: This equipment has been tested and found to comply with the limits for a Class A digital device pursuant to Part 15 of the FCC Rules. These limits are designed to provide reasonable protection against harmful interference when the equipment is operated in a commercial environment. This equipment generates, uses, and can radiate radio frequency energy and, if not installed and used in accordance with the manufacturer's instruction manual, may cause harmful interference with radio communications. Operation of this equipment in a residential area is likely to cause harmful interference, in which case you will be required to correct the interference at your own expense.

California Best Management Practices Regulations for Perchlorate Materials: This Perchlorate warning applies only to products containing CR (Manganese Dioxide) Lithium coin cells. "Perchlorate Material-special handling may apply. See www.dtsc.ca.gov/hazardouswaste/perchlorate".

WARNING: Handling of lead solder materials used in this product may expose you to lead, a chemical known to the State of California to cause birth defects and other reproductive harm.

Manual Revision 1.0

Release Date: July 25, 2011

Unless you request and receive written permission from Super Micro Computer, Inc., you may not copy any part of this document.

Information in this document is subject to change without notice. Other products and companies referred to herein are trademarks or registered trademarks of their respective companies or mark holders.

Copyright © 2011 by Super Micro Computer, Inc.
All rights reserved.

Printed in the United States of America

Preface

This manual is written for system integrators, PC technicians and knowledgeable PC users. It provides information for the installation and use of the X8QB6-LF/X8QBE-LF motherboard.

About This Motherboard

The X8QB6-LF/X8QBE-LF motherboard supports the Intel E7-4800/7500 processor that utilizes Intel QuickPath Interconnect (QPI) Technology to provide point-to-point system interface, replacing the Front Side Bus technology. Integrating Intel Turbo Boost Technology, 45nm Process Technology, combined with support of up to 4D CPU cores and 24MB L3 cache, the X8QB6-LF/X8QBE-LF motherboard substantially enhances system performance for HPC/Cluster/Database server platforms. Please refer to our Website (<http://www.supermicro.com>) for updates on processor and memory support. This product is intended to be installed and serviced by professional technicians.

Manual Organization

Chapter 1 provides quick installation instructions.

Chapter 2 describes the features, specifications and performance of the motherboard, and provides detailed information about the Intel 7500 chipset.

Chapter 3 provides hardware installation instructions. Read this chapter when installing the processor, memory modules and other hardware components into the system. If you encounter any problems, see **Chapter 4**, which describes troubleshooting procedures for video, memory, and system setup stored in the CMOS.

Chapter 5 includes an introduction to the BIOS, and provides detailed information on running the CMOS Setup utility.

Appendix A provides BIOS Error Beep Codes.

Appendix B lists Software Installation Instructions.

Conventions Used in the Manual

Special attention should be given to the following symbols for proper installation and to prevent damage to the system or injury to yourself:



Danger/Caution: Instructions to be strictly followed to prevent catastrophic system failure or to avoid bodily injury



Warning: Important information given to ensure proper system installation or to prevent damage to the components



Note: Additional information given to differentiate between various models or provides information for correct system setup.

Contacting Supermicro

Headquarters

Address: Super Micro Computer, Inc.
980 Rock Ave.
San Jose, CA 95131 U.S.A.

Tel: +1 (408) 503-8000

Fax: +1 (408) 503-8008

Email: marketing@supermicro.com (General Information)
support@supermicro.com (Technical Support)

Website: www.supermicro.com

Europe

Address: Super Micro Computer B.V.
Het Sterrenbeeld 28, 5215 ML
's-Hertogenbosch, The Netherlands

Tel: +31 (0) 73-6400390

Fax: +31 (0) 73-6416525

Email: sales@supermicro.nl (General Information)
support@supermicro.nl (Technical Support)
rma@supermicro.nl (Customer Support)

Asia-Pacific

Address: Super Micro Computer, Inc.
4F, No. 232-1, Liancheng Rd.
Chung-Ho 235, Taipei County
Taiwan, R.O.C.

Tel: +886-(2) 8226-3990

Fax: +886-(2) 8226-3991

Website: www.supermicro.com.tw

Technical Support:

Email: support@supermicro.com.tw

Tel: +886-(2) 8226-5990

Table of Contents

Preface

Chapter 1 Quick Installation Guide

1-1	Installing the CPU	1-1
1-2	Installing the CPU/Heatsink/CPU Fans.....	1-1
1-3	Installing the Memory Modules	1-2
1-4	Installing the I/O Shield.....	1-2
1-5	Installing the Motherboard	1-3
1-6	Connecting the Power Supply.....	1-3
1-7	Installing Internal Peripherals.....	1-4
1-8	Installing External Peripherals	1-4

Chapter 2 Overview

2-1	Overview	2-1
2-2	Chipset Overview	2-11
2-3	Special Features	2-12
2-4	PC Health Monitoring.....	2-12
2-5	ACPI Features.....	2-13
2-6	Power Supply	2-13
2-7	Super I/O.....	2-14
2-8	Overview of the Nuvoton WPCM450R Controller	2-14

Chapter 3 Installation

3-1	Static-Sensitive Devices.....	3-1
3-2	Processor and Heatsink Installation.....	3-2
	Installing an E7-4800/7500 Processor.....	3-2
	Installing a Passive CPU Heatsink	3-4
	Removing the Passive Heatsink	3-5
3-3	Installing and Removing the Memory Modules.....	3-6
	Installing & Removing DIMMs.....	3-6
	Removing Memory Modules	3-6
3-4	Motherboard Installation.....	3-10
	Tools Needed	3-10
	Location of Mounting Holes	3-10
	Installing the Motherboard	3-11
3-5	Control Panel Connectors/I/O Ports.....	3-12
	Back Panel Connectors/I/O Ports	3-12
	Back Panel I/O Port Locations and Definitions	3-12
	Serial Ports.....	3-13
	Video Connection.....	3-13

	Universal Serial Bus (USB).....	3-14
	Ethernet Ports	3-15
	Unit Identifier Switch	3-16
	Front Control Panel.....	3-17
	Front Control Panel Pin Definitions.....	3-18
	NMI Button	3-18
	Power LED	3-18
	HDD LED.....	3-19
	NIC1/NIC2 LED Indicators	3-19
	Overheat (OH)/Fan Fail/PWR Fail/UID LED	3-20
	Power Fail LED	3-20
	Reset Button	3-21
	Power Button	3-21
3-6	Connecting Cables.....	3-22
	Power Connectors	3-22
	Fan Headers.....	3-23
	Chassis Intrusion	3-23
	Internal Speaker.....	3-24
	Power LED/Speaker.....	3-24
	LPCI Port 80.....	3-25
	Overheat LED/Fan Fail	3-25
	Power SMB (I ² C) Connector	3-26
	IPMB.....	3-26
	T-SGPIO 1/2 Headers	3-27
	Wake-On-Ring.....	3-27
	Unit Identification Switch/LED	3-28
	RAIDKey Header (Optional for X8QB6-LF only).....	3-28
3-7	Jumper Settings	3-29
	Explanation of Jumpers	3-29
	GLAN Enable/Disable	3-29
	CMOS Clear	3-30
	Watch Dog Enable/Disable	3-30
	VGA Enable.....	3-31
	TPM Support Enable.....	3-31
	SAS2 Enable (X8QB6-LF only).....	3-32
	BMC Enable	3-32
	BMC Reset	3-33
	J_UID_OW (-Overwriting)	3-33
	ME Recovery	3-34

	Manufacturer Mode Select	3-34
3-8	Onboard LED Indicators	3-35
	GLAN LEDs.....	3-35
	IPMI Dedicated LAN LEDs.....	3-35
	Rear UID LED	3-36
	BMC Heartbeat LED	3-36
	Onboard Power LED	3-37
3-9	Serial ATA Connections.....	3-38
	Serial ATA Ports.....	3-38
	SAS2 Ports (X8QB6-LF only).....	3-38

Chapter 4 Troubleshooting

4-1	Troubleshooting Procedures	4-1
4-2	Technical Support Procedures	4-4
4-3	Frequently Asked Questions	4-5
4-4	Returning Merchandise for Service.....	4-6

Chapter 5 BIOS

5-1	Introduction.....	5-1
5-2	Main Setup	5-3
5-3	Advanced Setup Configurations.....	5-4
5-4	Boot Configuration	5-29
5-5	Security Settings	5-29
5-6	Exit Options.....	5-31

Appendix A BIOS Error Beep Codes

A-1	BIOS Error Beep Codes	A-1
-----	-----------------------------	-----

Appendix B Software Installation Instructions

B-1	Installing Software Programs	B-1
B-2	Configuring Supero Doctor III	B-2

Chapter 1

Quick Installation Guide

1-1 Installing the CPU

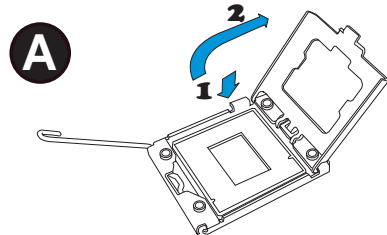

A. Press the socket clip down to unlock it. Gently lift the socket clip to open the load plate.

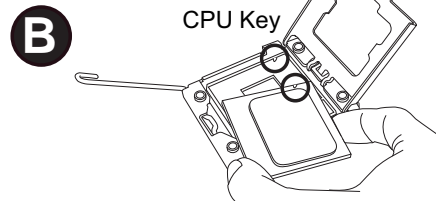

B. Align the CPU key with the socket key.

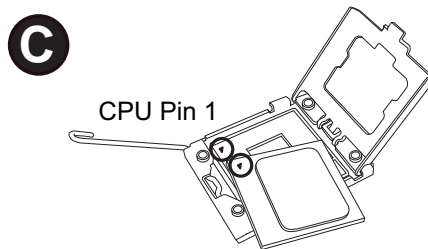

C. Align CPU Pin 1 against Socket Pin 1. Once they are aligned, lower the CPU down to the socket.

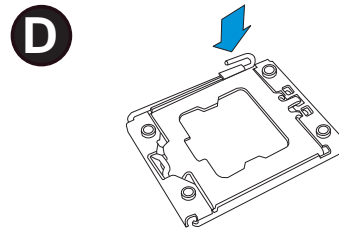

D. Once the CPU is fully seated on the socket, press the socket clip down to lock it.

 To avoid damage, do not rub the CPU pins against the socket.

1-2 Installing the CPU/Heatsink/CPU Fans

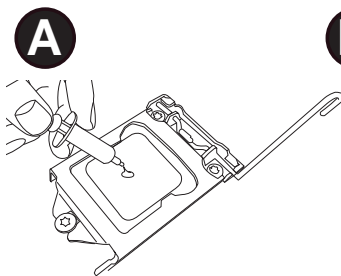

A. Apply the appropriate amount of thermal grease (to 0.13mm in thickness).

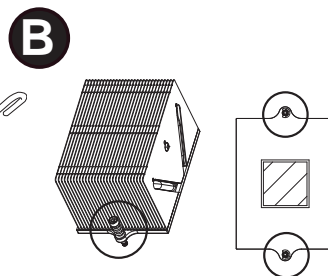

B. Insert the two push-pins on the sides of the heatsink into the mounting holes on the motherboard, turning clockwise to lock them.

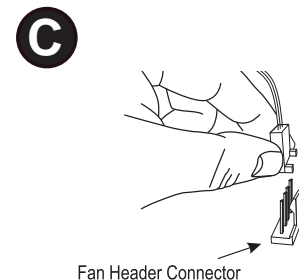

C. Connect the fan cables to CPU Fan1 and CPU Fan 2 headers.

1-3 Installing the Memory Modules

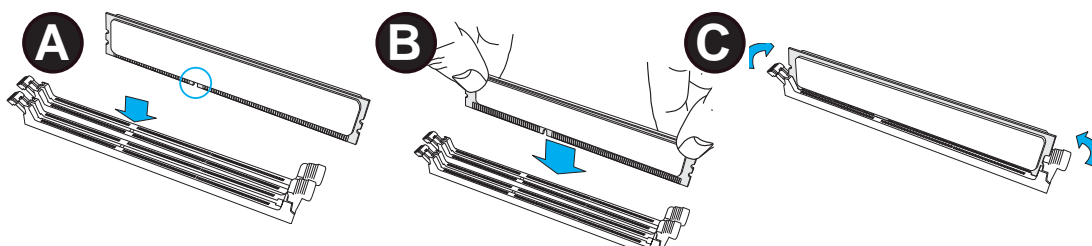

A. Press the release tabs on the both ends of the DIMM socket outwards to unlock it.

Align the key on the DIMM module against that of the DIMM socket.

B. Use two thumbs to press both notches of the module straight down into the DIMM socket.

C. Press the release tabs on the ends of the DIMM module inwards to lock it.

1-4 Installing the I/O Shield

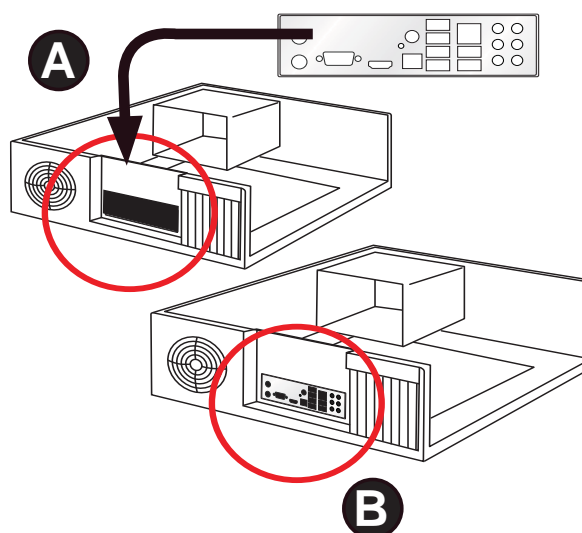

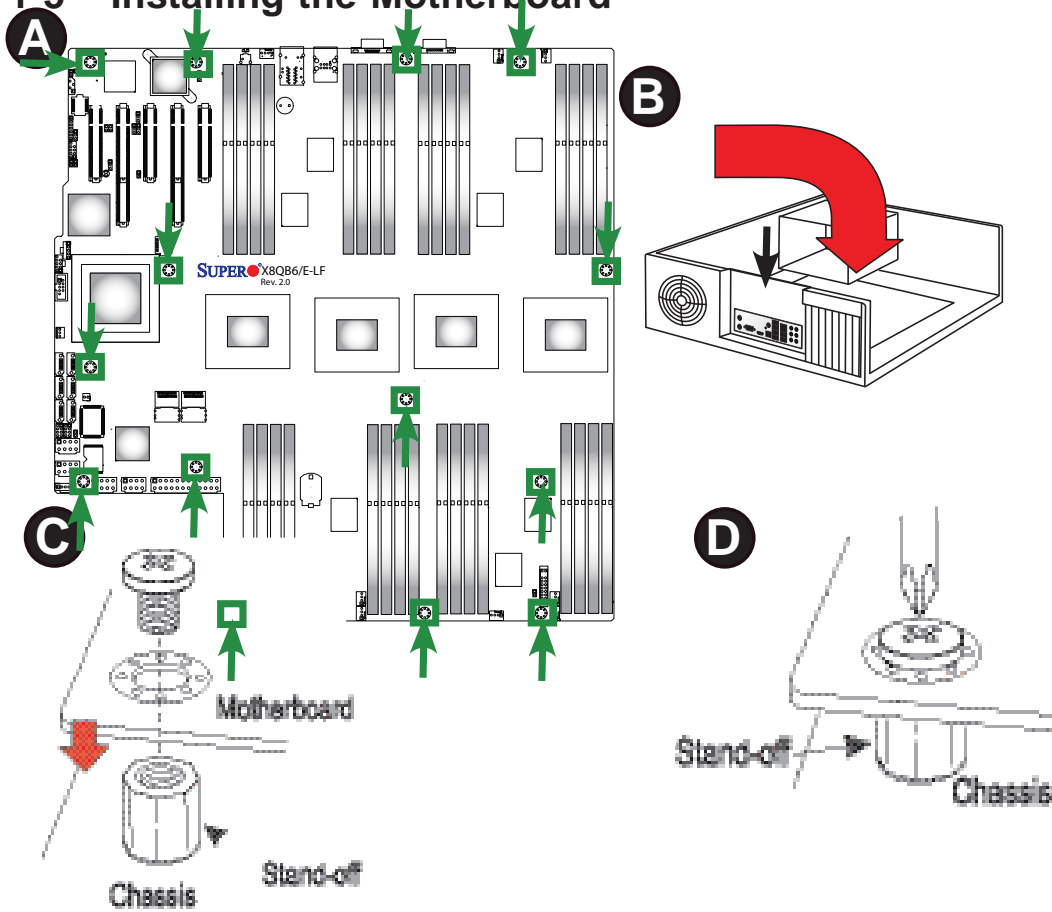

Note: Chassis and I/O plate images are for illustration purposes only. They may be different from what you have in your system.

1-5 Installing the Motherboard

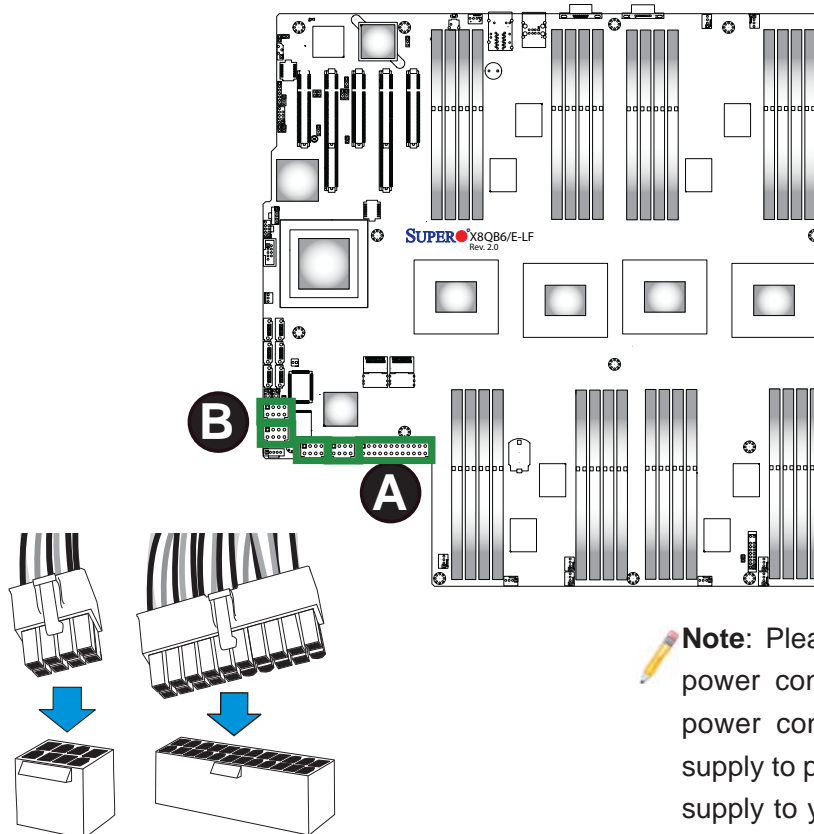

1-6 Connecting the Power Supply



 **Note:** Please connect the 24-pin power connector and *four* 8-pin power connectors to the power supply to provide adequate power supply to your system.

1-7 Installing Internal Peripherals

A SATA/SAS2 Drives

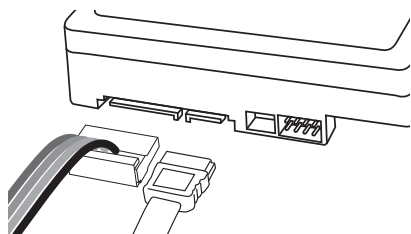

B Add-on Cards

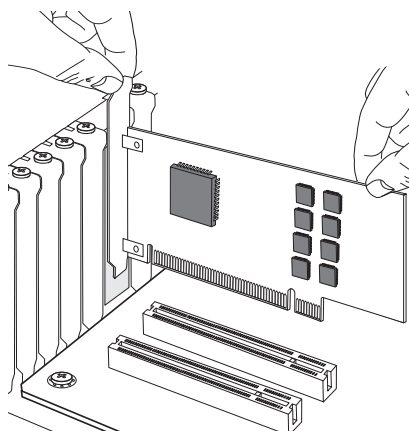

1-8 Installing External Peripherals

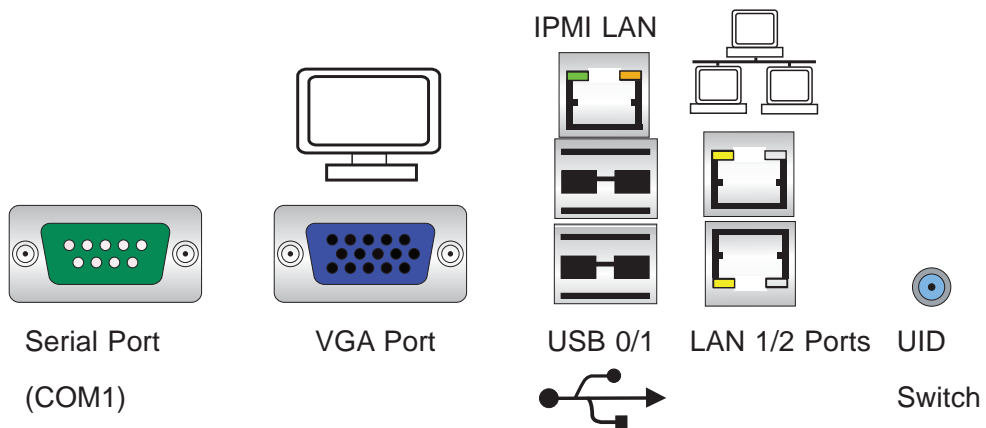

Chapter 2

Overview

2-1 Overview

Checklist

Congratulations on purchasing your computer motherboard from an acknowledged leader in the industry. Supermicro boards are designed with the utmost attention to detail to provide you with the highest standards in quality and performance.

Please check that the following items have all been included with your motherboard. If anything listed here is damaged or missing, contact your retailer.

The following items are included in the retail box.

- One (1) Supermicro Mainboard
- Six (6) Serial ATA cables (CBL-0044Lx6) (for X8QBE-LF)
- Two (2) I-Pass to 4 Serial ATA (50-cm) cables (CBL-097L-02) (for X8QB6-LF)
- One (1) Supermicro CD containing drivers and utilities
- One (1) User's/BIOS Manual

Optional (Required for Extended Battery Backup Support - X8QB6-LF only)

The items listed below are available for purchase at Supermicro.

- One (1) iBBU07 Battery (BTR-0018L-0000-LSI)
- One (1) BBU Adaptor (BTR-0018L-ADPT)
- One (1) Extension Cable (CBL-0420L)
- One (1) BBU Bracket (MCP-240-00094-0N)
- One (1) RAIDKey (AOC-SAS2-RAID5-KEY)

SUPER Motherboard Image

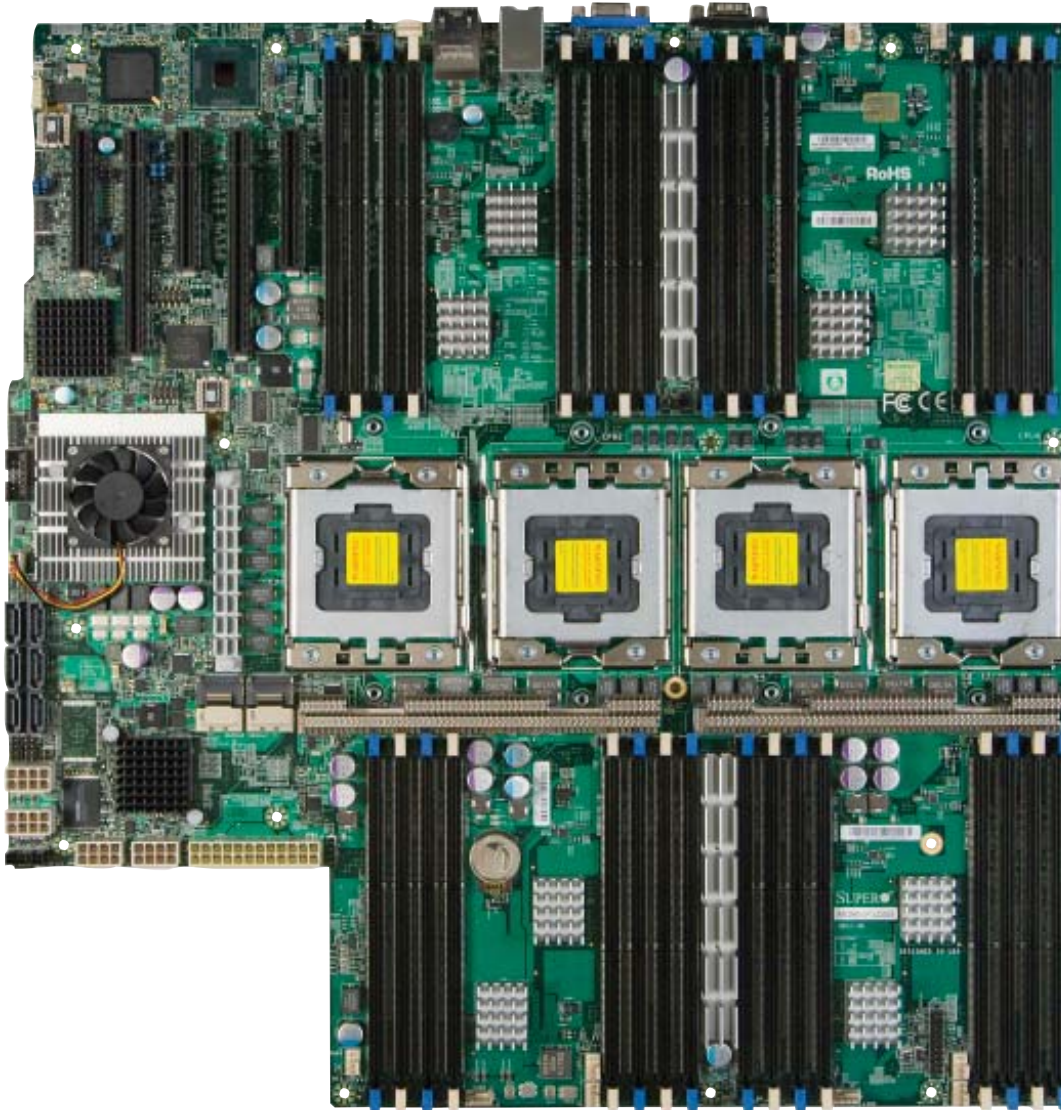

 **Note:** All graphics shown in this manual were based upon the latest PCB Revision available at the time of publishing of the manual. The motherboard you've received may or may not look exactly the same as the graphics shown in this manual.

Motherboard Layout

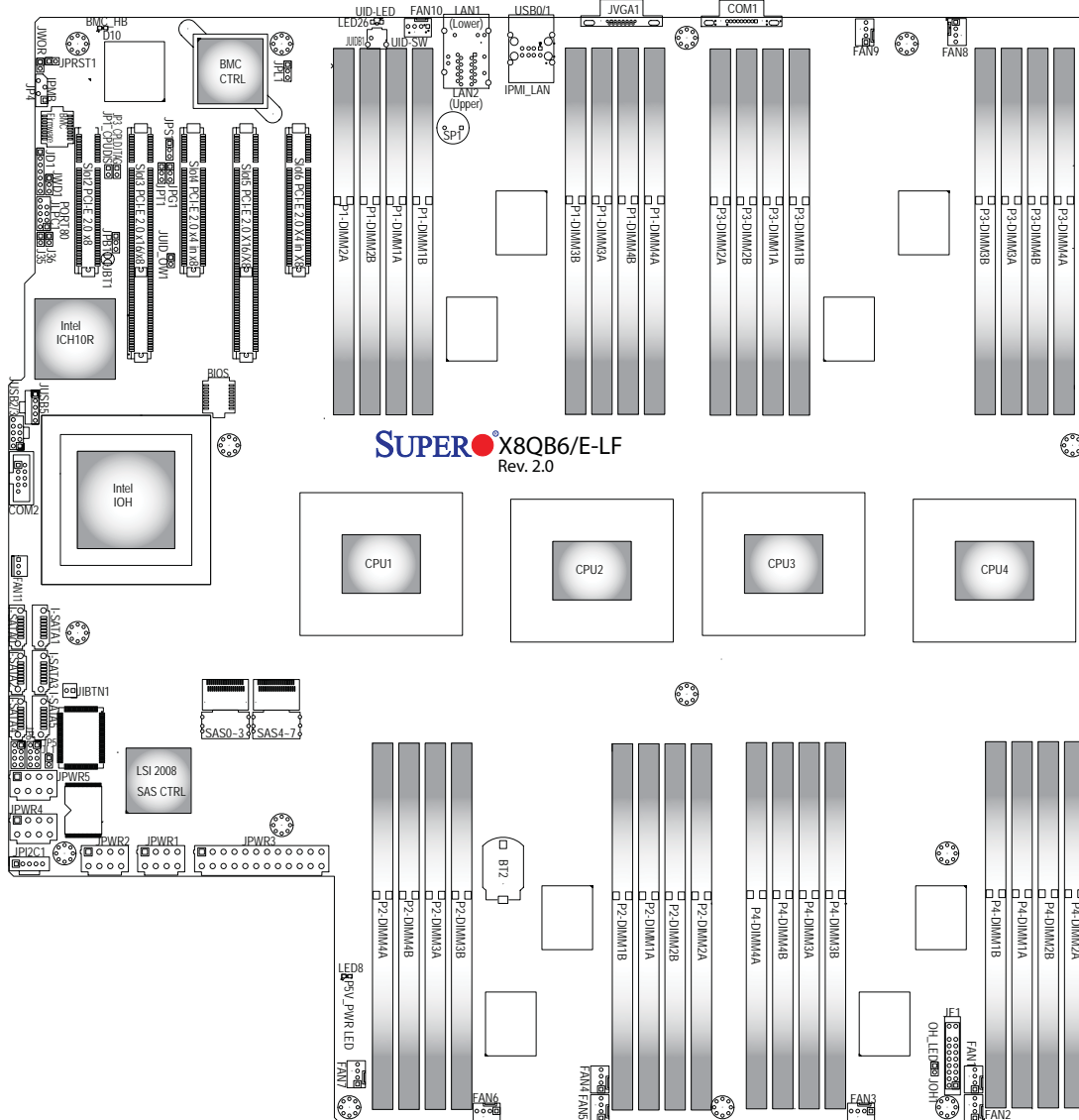

Note 1: The model name of this board is located next to P4-DIMM3B.

Note 2: SAS2 connections and the LSI 2008 SAS2 Controller are available on the X8QB6-LF only.

Note 3: For the latest CPU/Memory updates, please refer to our website at <http://www.supermicro.com/products/motherboard/> for details.

Note 4: For PCI-E 2.0 slot configuration, see Config. Tables on P. 2-9.

Note 5: To provide adequate power supply for proper system operation, use a power supply that supports the following specifications:

Type	Minimum Requirement
12V	1400 Watts (minimum)
5V Standby	6A (minimum)

X8QB6-LF/X8QBE-LF Quick Reference

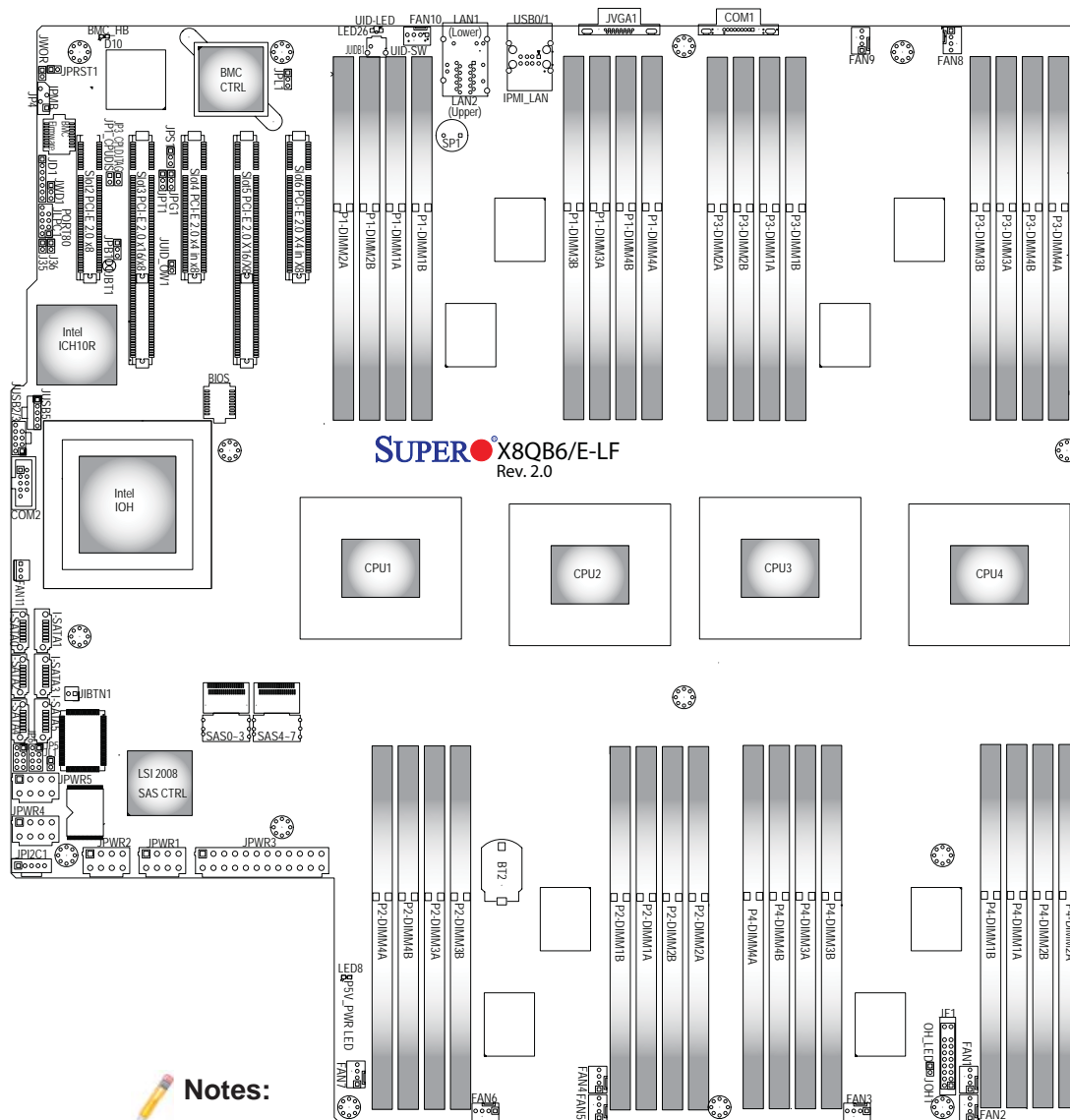

 **Notes:**

- See Chapter 3 for detailed information on jumpers, I/O ports and JF1 front panel connections.
- "■" indicates the location of "Pin 1".
- Jumpers not indicated are for testing only.
- The LSI SAS2 Controller and SAS2 Connections are available on the X8QB6-LF only.
- LED Indicators that are not documented are for testing only.
- Use only the correct type of onboard CMOS battery as specified by the manufacturer. Do not install the onboard battery upside down to avoid possible explosion.

X8QB6-LF/X8QBE-LF Jumpers		
Jumper	Description	Default Setting
J35	JPME1 (Manufacture Mode Select)	Off (Normal)
J36	JPME2 (ME Recovery)	Off (Normal)
JBT1	Clear CMOS	See Chapter 3
JPB1	BMC Enabled	Pins 1-2 (Enabled)
JPG1	VGA Enabled	Pins 1-2 (Enabled)
JPL1	GLAN1/GLAN2 Enable	Pins 1-2 (Enabled)
JPRST1	BMC Reset	Off (Normal)
JPS1 (X8QB6-LF only)	SAS2 Enabled	Pins 1-2 (Enabled)
JPT1	TPM Enabled	Pins 1-2 (Enabled)
JWD1	Watch Dog	Pins 1-2 (Reset)

X8QB6-LF/X8QBE-LF Connectors	
Connectors	Description
BT2	Onboard Battery (See Chpt. 4 for Used Battery Disposal)
COM1/COM2	Backplane COM Port1/Front Accessible COM2 Header
FAN1~11	CPU/System Fan Headers (Fan1~Fan10) (Fan11: Reserved)
IPMB (JP4)	4-pin External BMC I ² C Header (for an IPMI Card)
I-SATA 0~5	Intel SB SATA Connectors 0~5
JD1	Speaker/Power LED Indicator
JF1	Front Panel Control Header
JIBTN1	RAID_Key for RAID support (X8QB6-LF only)
JL1	Chassis Intrusion
JLPC1	LPCI (Low-Profile PCI) Port 80
JOH1	Overheat/Fan Fail LED
JP1	CPU Diagnosis
JP3	CPU_JTAG
JP5/JP6	T-SGPIO (Serial Link General Purpose I/O Headers) 1/2
JPI ² C1	Power Supply SMBbus I ² C Header
JPWR1~2, JPWR4~5	12V 8-Pin Power Connectors (See Warning on Pg. 2-6.)
JPWR3	ATX 24-Pin Power Connector (See Warning on Pg. 2-6.)
JUID_OW1	UID Override Header
JWOR	Wake-On-Ring Header
LAN1/LAN2	G-bit Ethernet Ports 1/2

(IPMI) LAN	IPMI_Dedicated LAN
SAS 0~3, 4~7	Serial_Attached_SCSI Connectors 0~3, 4~7 (X8QB6-LF)
SP1	Onboard Buzzer (Internal Speaker)
Slot2	PCI-Express 2.0 x8 (See PCI Config. Tables on P. 2-9)
Slot3, Slot5	PCI-Exp. 2.0 x16/X8 (See PCI Config. Tables on P. 2-9)
Slot4, Slot6	PCI-Exp 2.0 x4 in x8 (See PCI Config. Tables on P. 2-9)
BP USB 0/1	Back Panel USB 0/1
USB 2/3, USB 5	Front Panel Accessible USB Connections (JUSB2/3, JUSB50)
UID Switch	UID (Unit Identifier) Switch
VGA (JVGA1)	Backpanel VGA Port

X8QB6-LF/X8QBE-LF LED Indicators

LED	Description	State	Status
D10	BMC Heartbeat LED	Green: Blinking	Normal
LED 8	Standby PWR LED	Green: On	SB Power On
LED 26	UID LED	Blue: On (Windows OS), Blinking (Linux)	Unit Identified



Warning!

- To prevent damage to the power supply or motherboard, please use a power supply that contains a 24-pin and at least three 8-pin power connectors. Be sure to connect these power supply connectors to the 24-pin power connector (JPWR3) and three of the 8-pin power connectors (JPWR1, JPWR2, JPWR4 or JPWR5) on the motherboard. Failure in doing so will void the manufacturer warranty on your power supply and motherboard.





Note 1: To enable extended battery backup support for onboard SAS, please purchase a LSI 2008 SAS Battery Accessory kit from Supermicro. Refer to Page 3-26 in Chapter 3 for more details.

Note 2: For PCI-E slot configuration options, see the PCI-E Configuration Tables on Page 2-9.

Note 3: To ensure adequate power supply to the motherboard for proper system operation, please use a power supply that supports the following specifications:

Type	Minimum Requirement
12V	1400 Watts (minimum)
5V Standby	6A (minimum)

Motherboard Features

CPU	<ul style="list-style-type: none"> Four Intel® E7-4800/7500 processors; each processor supports four full-width Intel QuickPath Interconnect (QPI) links (with support of up to 25.6 GT/s per QPI link and with Data Transfer Rate of up to 6.4 GT/s per direction)
Memory	<ul style="list-style-type: none"> Integrated memory controller supports: <ol style="list-style-type: none"> 32 240-pin DDR3 Registered ECC DIMMs running at speeds of 1066/978/800 MHz (via an onboard buffer) Support of up to 1 TB (per Intel's specs.) of memory in dual channel bus <p> Note: For the latest CPU/memory updates, please refer to our website at http://www.supermicro.com/products/motherboard.</p>
	DIMM sizes
	<ul style="list-style-type: none"> RDIMM 1GB, 2GB, 4GB, 8GB and 16GB
	<ul style="list-style-type: none"> Virtualization: VT-x, VT-d, and VT-c
	<ul style="list-style-type: none"> I/O: Intel® QuickData Technology with Intel 82576 LAN Controller, supports: <ol style="list-style-type: none"> Intel 82576 LSI 2008 (Hardware RAID w/Battery Backup)
Chipset	<ul style="list-style-type: none"> Intel® 7500 Chipset (7500 IOH & ICH10R)
Expansion Slots	<ul style="list-style-type: none"> Two (2) PCI Express 2.0 x16 or x8 slots (Slot3/Slot5), One (1) PCI Express 2.0 x8 slot (Slot2), Two (4) PCI Express 2.0x4 in x8 slots with auto-switch from x8 to 2 (Two) x4 (Slot4/Slot6) <p> Note: For PCI-E slot configuration options, see the PCI-E Configuration Tables on Page 2-9.</p>
Graphics	<ul style="list-style-type: none"> Winbond BMC Video Controller (Matrox G200eW)
Network	<ul style="list-style-type: none"> One Intel 82576 Gigabit (10/100/1000 Mb/s) Ethernet Dual-Channel Controller for LAN 1/LAN 2 ports.
	<ul style="list-style-type: none"> Winbond WP450R Base-board Controller (BMC) supports IPMI_LAN 2.0

I/O Devices	SATA Connections	
	• SATA Ports	Six (6)
	• RAID (Windows)	RAID 0, 1, 10 *RAID 5 Optional (via RAID-Key)
	• RAID (Linux)	RAID 0, 1, 10
	SAS2 Connections	
	• LSI SAS2 2008 Controller	
	• SAS2 Ports	0~3, 4~7
	• RAID Support	RAID 0, 1, 10, RAID 5 support (via RAIDKey)
	Integrated IPMI 2.0	
	• IPMI 2.0 supported by the WPCM450R BMC	
	Serial (COM) Port	
• Two (1) Fast UART 16550 Connections (One backplane COM port, One front accessible Serial header)		
Super I/O		
• Winbond Super I/O 83527		
Peripheral Devices	USB Devices	
	<ul style="list-style-type: none"> • Two (2) USB ports on the rear I/O panel (USB 0/1) • Three (3) USB connection for front access (USB 2/3, USB 5) 	
BIOS	<ul style="list-style-type: none"> • 64 Mb SPI AMI BIOS® SM Flash BIOS • APM 1.2, DM 2.3, PCI 2.3, ACPI 1.0/2.0/3.0, USB Keyboard, Plug & Play (PnP) and SMBIOS 2.5 	
	<ul style="list-style-type: none"> • ACPI/ACPM Power Management • Main switch override mechanism • Keyboard Wake-up from Soft-Off • Power-on mode for AC power recovery 	
PC Health Monitoring	CPU Monitoring	
	<ul style="list-style-type: none"> • Onboard voltage monitors for CPU1~4 Vcores, NIC Vcore, BMC Vcore, AUX Vcore, Standby ME Vcore, 12V, 1.5V, 3.3V, 3.3VSB, Battery Voltage, and IOPV12. • CPU 7-Phase switching voltage regulator 	

	<ul style="list-style-type: none"> • CPU/System overheat LED and control • CPU Thermal Trip support • Thermal Monitor 2 (TM2) support
	Fan Control
	<ul style="list-style-type: none"> • Fan status monitoring with firmware 4-pin (Pulse Width Modulation) fan speed control • Low noise fan speed control
System Management	<ul style="list-style-type: none"> • PECI (Platform Environment Configuration Interface) 2.0 support
	<ul style="list-style-type: none"> • System resource alert via Supero Doctor III
	<ul style="list-style-type: none"> • SuperoDoctor III, Watch Dog, NMI
	<ul style="list-style-type: none"> • Chassis Intrusion Header and Detection
Dimensions	<ul style="list-style-type: none"> • 16.79" (L) x 16.00" (W) (426.46 mm x 406.40 mm)

PCI-E 2.0 Configuration Options (for Slots 2/3 and Slots 4/5/6)

PCI-E 2.0 Configuration Options for Slots 2/3		
	Slot 2	Slot 3
Option 1	Not available	x16 device(s) installed
Option 2	x8 device(s) installed	Downgrading to x8

PCI-E 2.0 Configuration Options for Slots 4/5/6			
	Slot 4	Slot 5	Slot 6
Option 1	Not available	x16	Not Available
Option 2	x8	Downgrading to x8	Not Available
Option 3	x4	Downgrading to x8	x4

 **Note:** For IPMI Configuration Instructions, please refer to the Embedded IPMI Configuration User's Guide available @ <http://www.supermicro.com/support/manuals/>.

2-2 Chipset Overview

Built upon the functionality and the capability of the Intel 7500 platform, the X8QB6-LF/X8QBE-LF motherboard provides the performance and support for quad_processor-based HPC/Cluster/Database servers. The 7500 platform consists of the E7-4800/7500 processor, the 7500 (IOH), and the ICH10R (South Bridge).

With the Intel QuickPath interconnect (QPI) controller built in, the E7-4800/7500 processor offers point-to-point system interconnect interface, enhancing system performance by utilizing serial link interconnections with increased bandwidth and scalability.

The 7500 IO Hub provides the interface between QPI-based processor, and industry-standard PCI-Express components. Each processor supports four full-width, bidirectional interconnects that run at the speed of 4.8 GT/s, 5.86 GT/s or 6.4 GT/s. Each QPI link consists of 20 pairs of unidirectional differential lanes for data transmission in addition to a differential forwarded clock. The two x16 PCI Express Gen 2 connections can also be configured as x8 and x4 links to comply with PCI-E Base Specification, Rev. 2.0. These PCI-E Gen 2 lanes support peer-to-peer read and write transactions. In addition, the legacy IOH provides a x4 ESI (Enterprise South Bridge Interface) link support for the legacy bridge.

The 7500 chipset also offers a wide range of ESI, Intel® I/OAT Gen 3, Intel VT-d and RAS (Reliability, Availability and Serviceability) support. The features supported include memory interface ECC, x4/x8 Single Device Data Correction (SDDC), Flow-through CRC (Cyclic Redundancy Check), parity protection, out-of-band register access via SMBus, memory mirroring, and Hot-plug support on the PCI-Express Interface.

Main Features of the 7500 Platform

- Fully-connectivity (with four Intel® QuickPath Interconnects and up to eight cores in each socket with 24MB of shared last level (L3) cache supported)
- CPU-Integrated memory controller with support of DDR-3 1066 MHz RDIMMS running at 800/978/1066 MHz via a memory buffer
- Virtualization Technology, Integrated Manageability Engine (ME) supported
- 44 bits physical address and 48 bits virtual address supported

2-3 Special Features

Recovery from AC Power Loss

The Basic I/O System (BIOS) provides a setting for you to determine how the system will respond when AC power is lost and then restored to the system. You can choose for the system to remain powered off (in which case you must press the power switch to turn it back on), or for it to automatically return to the power-on state. See the Advanced BIOS Setup section for this setting. The default setting is **Last State**.

2-4 PC Health Monitoring

This section describes the PC health monitoring features of the motherboard. This motherboard has an onboard System_Hardware_Monitor chip that supports PC health monitoring. An onboard voltage monitor will scan the following onboard voltages continuously: CPU1 Vcore, CPU2 Vcore, CPU3 Vcore, CPU4 Vcore, +1.0V, +1.2V, +1.8V, +1.1V, +12V, 1.5V, 3.3V V, 3.3VSB, Battery Voltage, and IOPV12. Once a voltage becomes unstable, a warning is given or an error message is sent to the screen. The user can adjust the voltage thresholds to define the sensitivity of the voltage monitor.

Fan Status Monitor with Firmware Control

The PC health monitor can check the RPM status of the cooling fans. The onboard CPU and chassis fans are controlled by BIOS Thermal Management (under the Hardware Monitoring section in the Advanced Setting).

Environmental Temperature Control

A thermal control sensor monitors the CPU temperature in real time and will turn on the thermal control fan whenever the CPU temperature exceeds a user-defined threshold. The overheat circuitry runs independently from the CPU. Once it detects that the CPU temperature is too high, it will automatically turn on the thermal fan control to prevent the CPU from overheating. The onboard chassis thermal circuitry can monitor the overall system temperature and alert the user when the chassis temperature is too high.



Note: To avoid possible system overheating, please be sure to provide adequate airflow to your system.

System Resource Alert

This feature is available when used with Supero Doctor III in the Windows OS environment or used with Supero Doctor II in Linux. Supero Doctor is used to notify the user of certain system events. For example, you can configure Supero Doctor to provide you with warnings when the system temperature, CPU temperatures, voltages and fan speeds go beyond a predefined range.

2-5 ACPI Features

ACPI stands for Advanced Configuration and Power Interface. The ACPI specification defines a flexible and abstract hardware interface that provides a standard way to integrate power management features throughout a PC system, including its hardware, operating system and application software. This enables the system to automatically turn on and off peripherals such as CD-ROMs, network cards, hard disk drives and printers.

In addition to enabling operating system-directed power management, ACPI also provides a generic system event mechanism for Plug and Play, and an operating system-independent interface for configuration control. ACPI leverages the Plug and Play BIOS data structures, while providing a processor architecture-independent implementation that is compatible with Windows XP, Windows Vista and Windows 2008 Operating Systems.

Slow Blinking LED for Suspend-State Indicator

When the CPU goes into a suspend state, the chassis power LED will start blinking to indicate that the CPU is in suspend mode. When the user presses any key, the CPU will "wake up" and the LED will automatically stop blinking and remain on.

2-6 Power Supply

As with all computer products, a stable power source is necessary for proper and reliable operation. It is even more important for processors that have high CPU clock rates.

The X8QB6-LF/X8QBE-LF motherboard accommodates 24-pin ATX power supplies. Although most power supplies generally meet the specifications required by the CPU, some are inadequate. In addition, four 12V 8-pin power connections are also required to ensure adequate power supply to the system. Also, be sure to use a power supply that supports the specifications listed in the table on Page 2-3 or 2-6.



Warning! To prevent damage to the power supply or motherboard, please use a power supply that contains a 24-pin and at least three 8-pin power

connectors. Be sure to connect these power supply connectors to the 24-pin (JPWR3) and three of the four 8-pin power connectors (JPWR1, JPWR2, JPWR4, or JPWR5) on the motherboard. Failure to do so will void the manufacturer warranty on your power supply and motherboard.

It is strongly recommended that you use a high quality power supply that meets ATX power supply Specification 2.02 or above. It must also be SSI compliant. (For more information, please refer to the website at <http://www.ssiforum.org/>). Additionally, in areas where noisy power transmission is present, you may choose to install a line filter to shield the computer from noise. It is recommended that you also install a power surge protector to help avoid problems caused by power surges.

2-7 Super I/O

The Super I/O supports two high-speed, 16550 compatible serial communication ports (UARTs). Each UART includes a 16-byte send/receive FIFO, a programmable baud rate generator, complete modem control capability and a processor interrupt system. Both UARTs provide legacy speed with baud rate of up to 115.2 Kbps as well as an advanced speed with baud rates of 250 K, 500 K, or 1 Mb/s, which support higher speed modems.

The Super I/O provides functions that comply with ACPI (Advanced Configuration and Power Interface), which includes support of legacy and ACPI power management through an SMI or SCI function pin. It also features auto power management to reduce power consumption.

2-8 Overview of the Nuvoton WPCM450R Controller

The Nuvoton WPCM450R Controller is a Baseboard Management Controller (BMC) that supports the PCI-compatible 2D/VGA Graphics Core, Virtual Media, and Keyboard/Video/Mouse Redirection (KVMR) modules. With blade-oriented Super I/O capability built-in, the WPCM450R Controller is ideal for legacy-reduced server platforms.

The WPCM450R interfaces with the host system via a PCI interface to communicate with the Graphics core. It supports USB 2.0 and 1.1 for remote keyboard/mouse/virtual media emulation. It also provides LPC interface to control Super IO functions. The WPCM450R is connected to the network via an external Ethernet PHY module.

The WPCM450R communicates with onboard components via six SMBus interfaces, fan control, and Platform Environment Control Interface (PECI) buses.



Note: For more information on IPMI configuration, please refer to the Embedded IPMI User's Guide posted on our website @ <http://www.supermicro.com/support/manuals/>.

Chapter 3

Installation

3-1 Static-Sensitive Devices

Electrostatic Discharge (ESD) can damage electronic components. To avoid damaging your system board, it is important to handle it very carefully. The following measures are generally sufficient to protect your equipment from ESD.

Precautions

- Use a grounded wrist strap designed to prevent static discharge.
- Touch a grounded metal object before removing the board from the antistatic bag.
- Handle the board by its edges only; do not touch its components, peripheral chips, memory modules or gold contacts.
- When handling chips or modules, avoid touching their pins.
- Put the motherboard and peripherals back into their antistatic bags when not in use.
- For grounding purposes, make sure that your system chassis provides excellent conductivity between the power supply, the case, the mounting fasteners and the motherboard.

Unpacking

The motherboard is shipped in antistatic packaging to avoid static damage. When unpacking the board, make sure that the person handling it is static protected.

3-2 Processor and Heatsink Installation



When handling the processor package, avoid placing direct pressure on the label area of the fan.

Notes:

1. Always connect the power cord last, and always remove it before adding, removing or changing any hardware components. Make sure that you install the processor into the CPU socket before you install the CPU heatsink.
2. Make sure to install the motherboard into the chassis before you install the CPU heatsink and heatsink fans.
3. When purchasing a motherboard without an E7-4800/7500 processor pre-installed, make sure that the CPU socket plastic cap is in place, and none of the CPU socket pins are bent; otherwise, contact the retailer immediately.
4. Refer to the Motherboard Features Section of the manual and our website for more details on CPU support and updates.

Installing an E7-4800/7500 Processor

1. Press the socket clip to release the load plate, which covers the CPU socket, from its locking position.
2. Gently lift the socket clip to open the load plate.

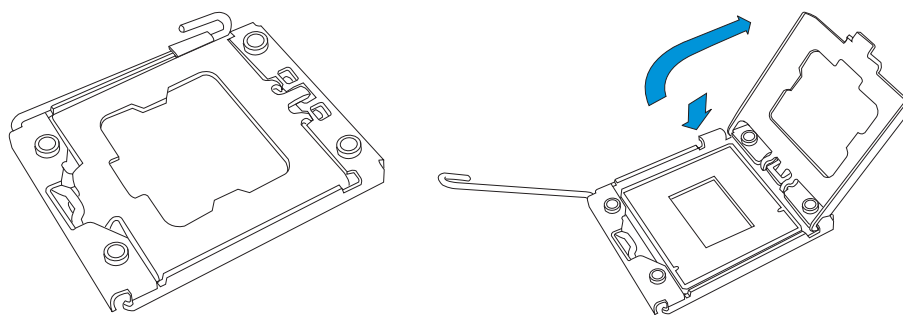

3. Hold the plastic cap at its north and south center edges to remove it from the CPU socket.

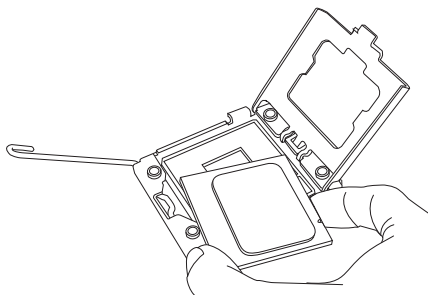

4. After removing the plastic cap, using your thumb and the index finger, hold the CPU at the north and south center edges.
5. Align the CPU key, which is a semi-circle cutout, against the socket key, which is the notch below the gold color dot on the side of the socket.

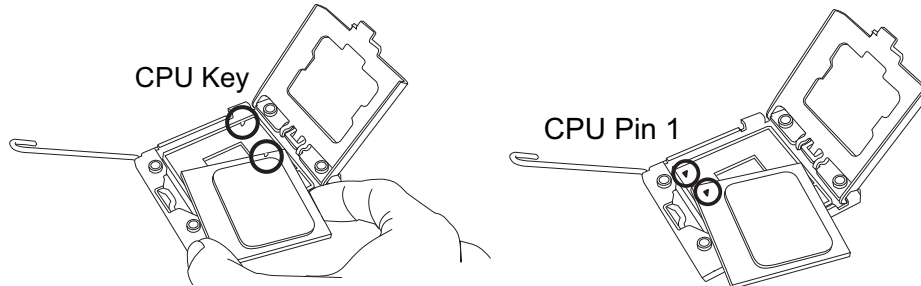

6. Align Pin 1 on the CPU against Pin 1 on the CPU socket.
7. Once both CPU and the socket are aligned, carefully lower the CPU straight down into the socket. (To avoid damaging the CPU or the socket, do not rub the CPU against the surface of the socket or its pins.)
8. With the CPU inside the socket, inspect the four corners of the CPU to make sure that the CPU is properly installed.
9. Once the CPU is securely seated on the socket, lower the CPU load plate to the socket.
10. Use your thumb to gently push the socket clip down to the clip lock.

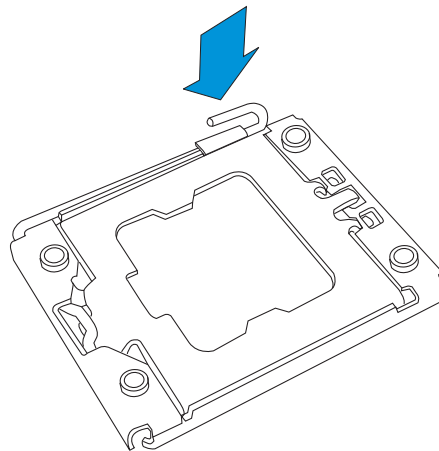

Warning: Please save the plastic cap. The motherboard must be shipped with the plastic cap properly installed to protect the CPU socket pins. Shipment without the plastic cap properly installed will cause damage to the socket pins.

Installing a Passive CPU Heatsink

1. Apply the proper amount of thermal grease to the heatsink.
2. Place the heatsink on top of the CPU so that the two mounting holes on the heatsink are aligned with those on the retention mechanism.
3. Insert two push-pins on the sides of the heatsink through the mounting holes on the motherboard, and turn the push-pins clockwise to lock them.

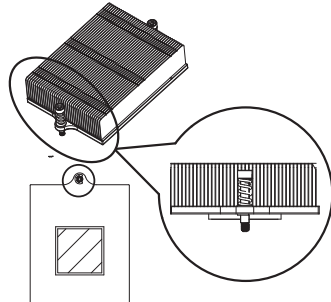

1U Heatsink (SNK-P0044P)

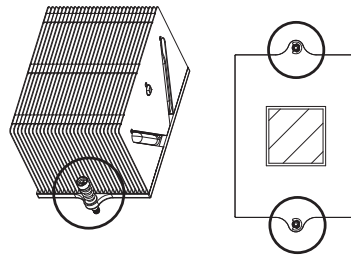

2U/4U Heatsink (SNK-P0045P)

Removing the Passive Heatsink



Warning: We do not recommend that the CPU or the heatsink be removed. However, if you do need to remove the heatsink, please follow the instructions below to uninstall the heatsink to avoid damaging the CPU or other components.

1. Unplug the power cord from the power supply.
2. Press down the push-pin on the heatsink, and turn counter-clock-wise to loosen it. Repeat the same step to loosen the second push-pin.
3. Hold the heatsink as shown in the picture below, and gently wriggle the heatsink to loosen it from the CPU. (Do not use excessive force when wriggling the heatsink.)

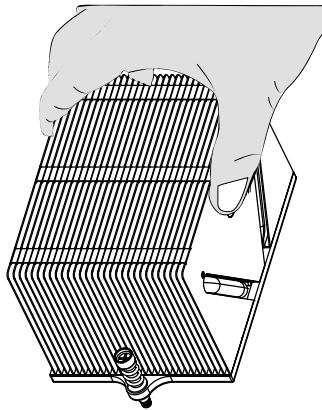

4. Once the heatsink is loosened, remove the heatsink from the motherboard.
5. To reinstall the CPU and the heatsink, clean the surface of the CPU and the heatsink to get rid of the old thermal grease. Reapply the proper amount of thermal grease on the surface before reinstalling them on the motherboard.



Notes:

1. CPU1 and CPU2 are required for a system boot. Populating CPU3 and/or CPU4 will not boot the system.
2. CPU3 and CPU4 are not connected to the I/O Hub (IOH).

3-3 Installing and Removing the Memory Modules

Note: Check Supermicro's website for recommended memory modules.



CAUTION

Exercise extreme care when installing or removing DIMM modules to prevent any possible damage.

Installing & Removing DIMMs

1. Insert the desired number of DIMMs into the memory slots, starting with P1-DIMM #1A. (For best performance, please use the memory modules of the same type and speed in the same bank.)
2. Push the release tabs outwards on both ends of the DIMM slot to unlock it.

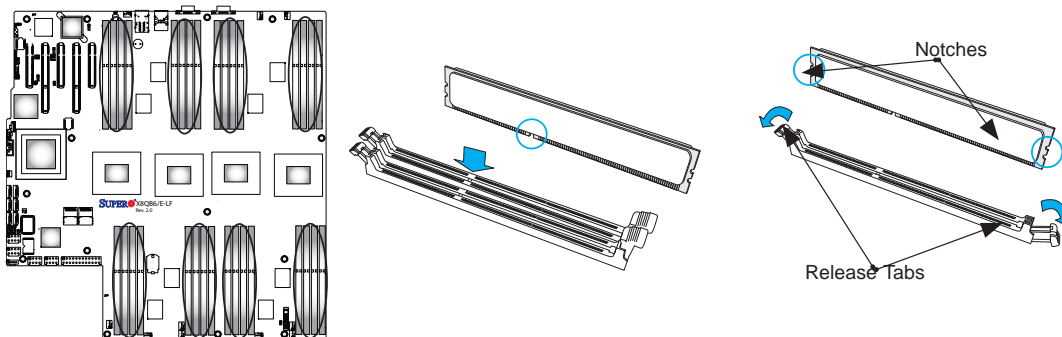

3. Align the key of the DIMM module with the receptive point on the memory slot.
4. Align the notches on both ends of the module against the receptive points on the ends of the slot.
5. Use two thumbs together to press the notches on both ends of the module straight down into the slot until the module snaps into place.
6. Press the release tabs to the lock positions to secure the DIMM module into the slot.

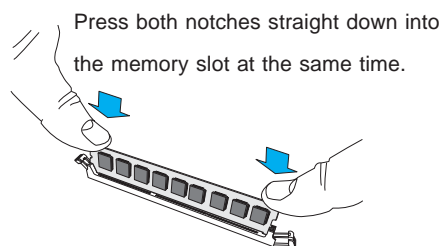

Removing Memory Modules

Reverse the steps above to remove the DIMM modules from the motherboard.

Memory Support for the X8QB6-LF/X8QBE-LF Motherboard

The X8QB6-LF/X8QBE-LF Motherboard supports up to 1 TB* Registered ECC DDR3 1066 MHz memory in 32 DIMM slots. These RDIMMs run at 800/978/1066 via a memory buffer. For the latest memory updates, please refer to our website at <http://www.supermicro.com/products/motherboard>. (*up to 1 TB of memory support per Intel's specs.)

Processor & Memory Module Population Configuration

For memory to work properly, follow the tables below for memory installation.

Memory Configuration for X8QB6/E-LF										
Mode	P1-P4-DIMM 2A	P1-P4-DIMM 2B	P1-P4-DIMM 1A	P1-P4-DIMM 1B			P1-P4-DIMM 3B	P1-P4-DIMM 3A	P1-P4-DIMM 4B	P1-P4-DIMM 4A
1	X	X	●	X			X	●	X	X
2	●	X	●	X		Mb1	X	●	X	●
3	●	●	●	●			●	●	●	●
4	X	X	●	●			●	●	X	x
5	●	X	●	●	Mb2		●	●	X	●
6	●	X	X	X			X	X	X	●
7	●	●	X	X			X	X	●	●
8	●	●	●	X			X	●	●	●

Note 1: Do not install memory modules on the slots marked X.
Note 2: Memory Configuration Instructions listed above are applicable to all P1-DIMM 1A~4B, P2-DIMM 1A~4B, P3-DIMM 1A~4B and P4-DIMM 1A~4B memory slots.

Processor and Memory Module Population	
Number of CPUs	CPU and Memory Population Configuration Table
1 CPU (CPU1)	(P1-) 1A-3A (2 DIMMs) (required for boot) (P1-) 1A-3A, 2A-4A (4 DIMMs) (P1-) 1A-3A, 2A-4A, 1B-2B, 3B-4B (8 DIMMs) (P1-) 1A-1B, 3A-3B (4 DIMMs) (P1-) 1A-1B-2A, 3A-3B-4A (6 DIMMs) (P1-) 2A-4A (2 DIMMs) (P1-) 2A-2B, 4A-4B (4 DIMMs) (P1-) 1A-2B-2A, 3A-4B-4A (6 DIMMs)
2 CPUs (CPU1+CPU2)	(P1-) 1A-3A (2 DIMMs) (P1-) 1A-3A, 2A-4A (4 DIMMs) (P1-) 1A-3A, 2A-4A, 1B-2B, 3B-4B (8 DIMMs) (P1-) 1A-1B, 3A-3B (2 DIMMs) (P1-) 1A-1B-2A, 3A-3B-4A (6 DIMMs) (P1-) 2A-4A (2 DIMMs) (P1-) 2A-2B, 4A-4B (4 DIMMs) (P1-) 1A-2B-2A, 3A-4B-4A (6 DIMMs) (P2-) 1A-3A (2 DIMMs) (P2-) 1A-3A, 2A-4A (4 DIMMs) (P2-) 1A-3A, 2A-4A, 1B-2B, 3B-4B (8 DIMMs) (P2-) 1A-1B, 3A-3B (2 DIMMs) (P2-) 1A-1B-2A, 3A-3B-4A (6 DIMMs) (P2-) 2A-4A (2 DIMMs) (P2-) 2A-2B, 4A-4B (4 DIMMs) (P2-) 1A-2B-2A, 3A-4B-4A (6 DIMMs)

<p>3 CPUs (CPU1+CPU2+CPU3)</p>	<p>(P1-) 1A-3A (2 DIMMs) (P1-) 1A-3A, 2A-4A (4 DIMMs) (P1-) 1A-3A, 2A-4A, 1B-2B, 3B-4B (8 DIMMs) (P1-) 1A-1B, 3A-3B (2 DIMMs) (P1-) 1A-1B-2A, 3A-3B-4A (6 DIMMs) (P1-) 2A-4A (2 DIMMs) (P1-) 2A-2B, 4A-4B (4 DIMMs) (P1-) 1A-2B-2A, 3A-4B-4A (6 DIMMs)</p> <p>(P2-) 1A-3A (2 DIMMs) (P2-) 1A-3A, 2A-4A (4 DIMMs) (P2-) 1A-3A, 2A-4A, 1B-2B, 3B-4B (8 DIMMs) (P2-) 1A-1B, 3A-3B (2 DIMMs) (P2-) 1A-1B-2A, 3A-3B-4A (6 DIMMs) (P2-) 2A-4A (2 DIMMs) (P2-) 2A-2B, 4A-4B (4 DIMMs) (P2-) 1A-2B-2A, 3A-4B-4A (6 DIMMs)</p> <p>(P3-) 1A-3A (2 DIMMs) (P3-) 1A-3A, 2A-4A (4 DIMMs) (P3-) 1A-3A, 2A-4A, 1B-2B, 3B-4B (8 DIMMs) (P3-) 1A-1B, 3A-3B (2 DIMMs) (P3-) 1A-1B-2A, 3A-3B-4A (6 DIMMs) (P3-) 2A-4A (2 DIMMs) (P3-) 2A-2B, 4A-4B (4 DIMMs) (P3-) 1A-2B-2A, 3A-4B-4A (6 DIMMs)</p>
<p>4 CPUs (CPU1~CPU4)</p>	<p>(P1-) 1A-3A (2 DIMMs) (P1-) 1A-3A, 2A-4A (4 DIMMs) (P1-) 1A-3A, 2A-4A, 1B-2B, 3B-4B (8 DIMMs) (P1-) 1A-1B, 3A-3B (2 DIMMs) (P1-) 1A-1B-2A, 3A-3B-4A (6 DIMMs) (P1-) 2A-4A (2 DIMMs) (P1-) 2A-2B, 4A-4B (4 DIMMs) (P1-) 1A-2B-2A, 3A-4B-4A (6 DIMMs)</p> <p>(P2-) 1A-3A (2 DIMMs) (P2-) 1A-3A, 2A-4A (4 DIMMs) (P2-) 1A-3A, 2A-4A, 1B-2B, 3B-4B (8 DIMMs) (P2-) 1A-1B, 3A-3B (2 DIMMs) (P2-) 1A-1B-2A, 3A-3B-4A (6 DIMMs) (P2-) 2A-4A (2 DIMMs) (P2-) 2A-2B, 4A-4B (4 DIMMs) (P2-) 1A-2B-2A, 3A-4B-4A (6 DIMMs)</p> <p>(P3-) 1A-3A (2 DIMMs) (P3-) 1A-3A, 2A-4A (4 DIMMs) (P3-) 1A-3A, 2A-4A, 1B-2B, 3B-4B (8 DIMMs) (P3-) 1A-1B, 3A-3B (2 DIMMs) (P3-) 1A-1B-2A, 3A-3B-4A (6 DIMMs) (P3-) 2A-4A (2 DIMMs) (P3-) 2A-2B, 4A-4B (4 DIMMs) (P3-) 1A-2B-2A, 3A-4B-4A (6 DIMMs)</p> <p>(P4-) 1A-3A (2 DIMMs) (P4-) 1A-3A, 2A-4A (4 DIMMs) (P4-) 1A-3A, 2A-4A, 1B-2B, 3B-4B (8 DIMMs) (P4-) 1A-1B, 3A-3B (2 DIMMs) (P4-) 1A-1B-2A, 3A-3B-4A (6 DIMMs) (P4-) 2A-4A (2 DIMMs) (P4-) 2A-2B, 4A-4B (4 DIMMs) (P4-) 1A-2B-2A, 3A-4B-4A (6 DIMMs)</p>
<p> Note: For memory to work properly, please install DIMMs in pairs. However, do not mix memory pairs. Mixed memory pairs such as 3A/2B will not work properly.</p>	

RDIMM Support POR on the E7-4800/7500 Series Processor Platform				
DIMM Slots per DDR Channel	DIMMs Populated per DDR Channel	RDIMM Type (RDIMM: Reg.= Registered)	POR Speeds (in MHz)	Ranks per DIMM (Any Combination)
1	1	Reg. ECC DDR3	800,978, 1066	SR, DR, or QR
2	1	Reg. ECC DDR3	800,978, 1066	SR, DR, or QR
2	2	Reg. ECC DDR3	800,978, 1066	Mixing SR, DR, QR

Population Rules:

1. Any combination of x4 and x8 RDIMMs with 1 Gb or 2 Gb DRAM Density are supported.
2. Populate DIMMs starting with DIMM1A.
3. When mixing QR with SR or DR on the same DDR channel, put the QR in DIMM1A first.

Other Notes and Restrictions

- Only DDR3 1066 RDIMMs are validated at speeds of 800, 978, 1066 MHz.
- For the memory modules to work properly, please install DIMM modules in pairs (w/even number of DIMMs installed). However, do not mix memory pairs. Mixed memory pairs such as 3A/2B will not work properly.
- All channels in a system will run at the fastest common frequency.

3-4 Motherboard Installation

All motherboards have standard mounting holes to fit different types of chassis. Make sure that the locations of all the mounting holes for both motherboard and chassis match. Although a chassis may have both plastic and metal mounting fasteners, metal ones are highly recommended because they ground the motherboard to the chassis. Make sure that the metal standoffs click in or are screwed in tightly. Then use a screwdriver to secure the motherboard onto the motherboard tray.

Tools Needed

- Phillips Screwdriver
- Pan head screws (14 pieces)
- Standoffs (14 pieces)
- Additional Standoffs Holes marked with grey arrows (3 locations on the chassis, if needed)

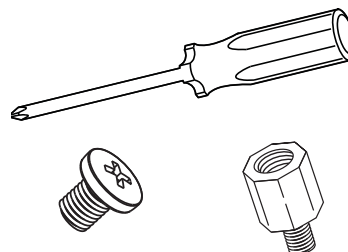

Location of Mounting Holes

There are 17 mounting holes on this motherboard indicated by the arrows.

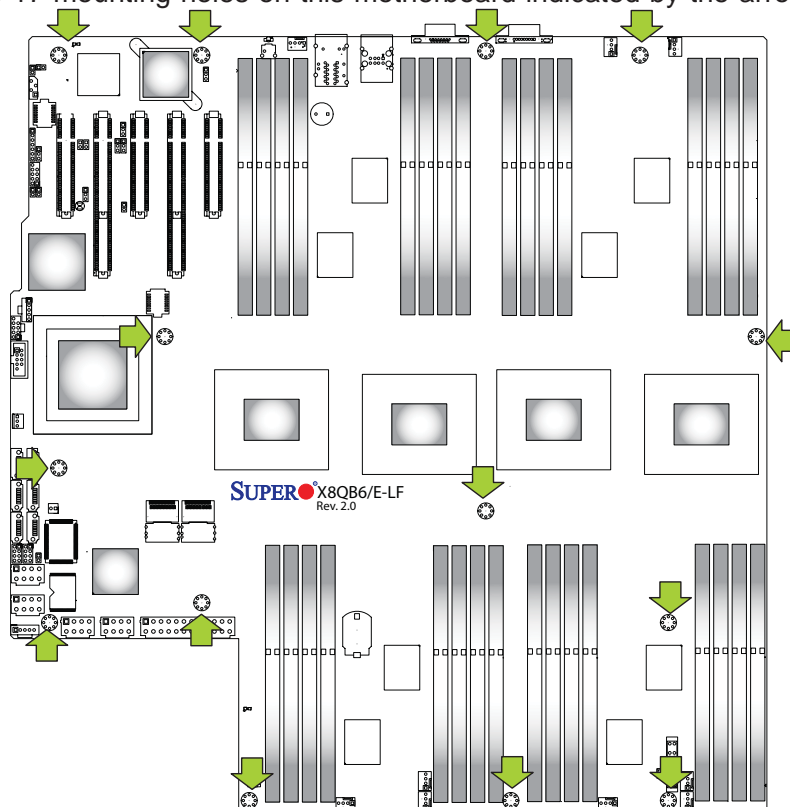

Caution: 1) To avoid damaging the motherboard and its components, please do not use a force greater than 8 lb/inch on each mounting screw during motherboard installation. 2) Some components are very close to the mounting holes. Please take precautionary measures to prevent damage to these components when installing the motherboard to the chassis.

Installing the Motherboard

1. Install the I/O shield into the chassis.

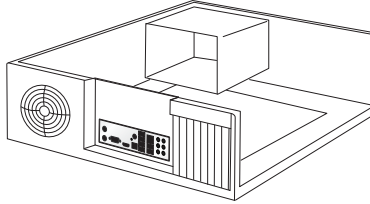

2. Locate the mounting holes on the motherboard.
3. Locate the matching mounting holes on the chassis. Align the mounting holes on the motherboard against the mounting holes on the chassis.
4. Install standoffs in the chassis as needed.

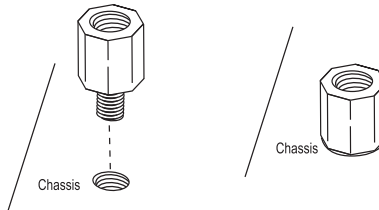

5. Install the motherboard into the chassis carefully to avoid damaging motherboard components.
6. Using the Philips screwdriver, insert a Pan head #6 screw into a mounting hole on the motherboard and its matching mounting hole on the chassis.

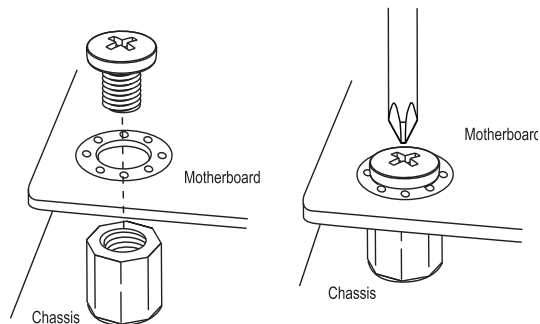

7. Repeat Step 5 to insert #6 screws into all mounting holes.
8. Make sure that the motherboard is securely placed in the chassis.



Note: Images displayed are is for illustration only. Your chassis or components might look different from those shown in this manual.

3-5 Control Panel Connectors/I/O Ports

The I/O ports are color coded in conformance with the PC 99 specification. See the picture below for the colors and locations of the various I/O ports.

Back Panel Connectors/I/O Ports

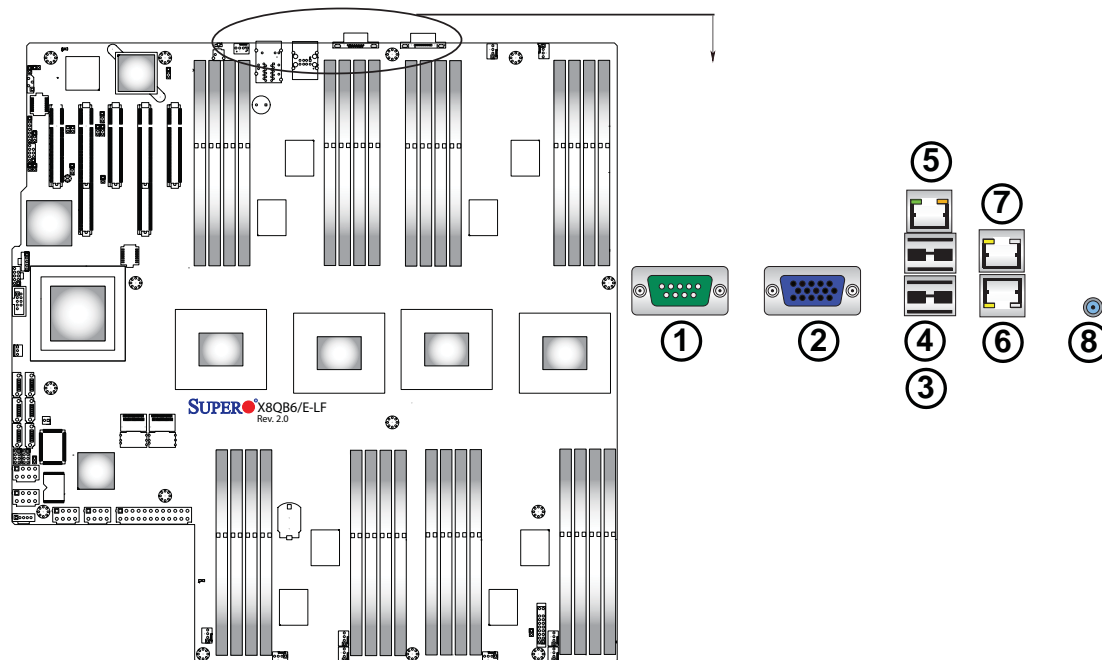

Back Panel I/O Port Locations and Definitions

1. COM Port 1 (Turquoise)
2. VGA (Blue) Back Panel
3. Back Panel USB Port 0
4. Back Panel USB Port 1
5. IPMI_Dedicated LAN
6. Gigabit LAN 1
7. Gigabit LAN 2
8. UID Switch

Serial Ports

Two COM connections (COM1 & COM2) are located on the motherboard. COM1 is located on the Backplane I/O panel. COM2, located close to the 7500 IOH, provides front accessible serial support. See the table on the right for pin definitions.

Serial COM) Ports Pin Definitions			
Pin #	Definition	Pin #	Definition
1	DCD	6	DSR
2	RXD	7	RTS
3	TXD	8	CTS
4	DTR	9	RI
5	Ground	10	N/A

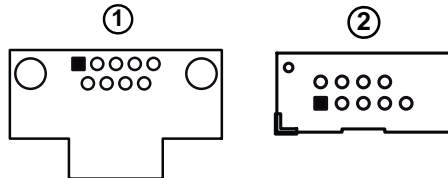

Video Connection

A Video (VGA) port is located next to COM1 on the I/O backplane. Refer to the board layout below for the location.

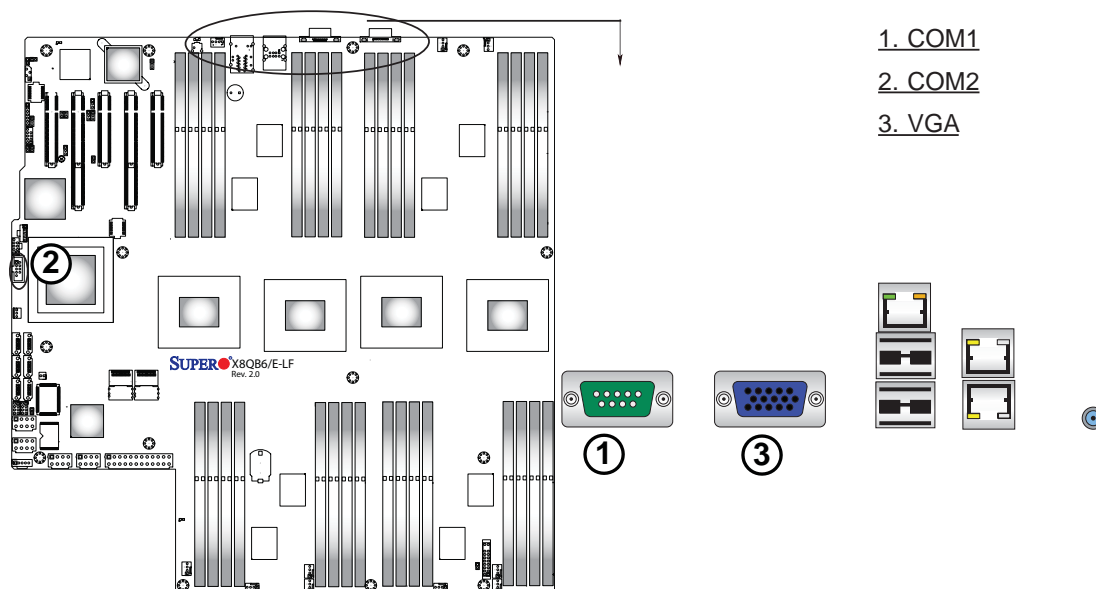

Universal Serial Bus (USB)

Two Universal Serial Bus ports (USB 0/1) are located on the I/O back panel. Additional Front Panel USB connections (USB 2/3, USB5) are on the motherboard to provide front chassis access. (Cables are not included). See the tables on the right for pin definitions.

Backplane USB (0/1) Pin Definitions	
Pin#	Definition
1	+5V
2	PO-
3	PO+
4	Ground
5	NA

FP USB (2/3, 5) Pin Definitions			
USB 2		USB 3/5	
Pin #	Definition	Pin #	Definition
1	+5V	1	+5V
2	PO-	2	PO-
3	PO+	3	PO+
4	Ground	4	Ground
5	NC	5	Key

(NC= No connection)

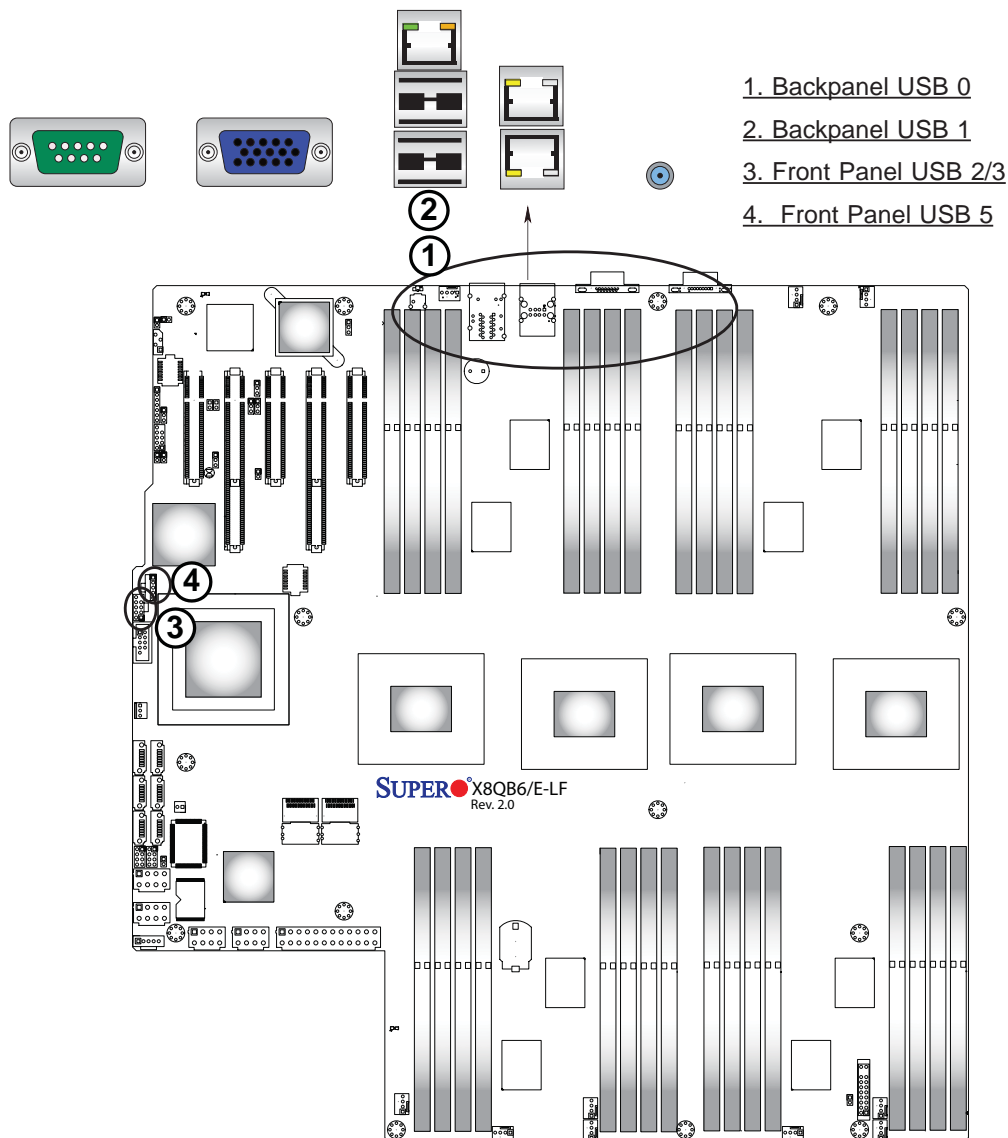

Ethernet Ports

Two Ethernet ports (LAN1/LAN2) are located on the I/O backplane on the motherboard. In addition, an IPMI_Dedicated LAN is located above USB 0/1 ports on the backplane to provide KVM support for IPMI 2.0. All these ports accept RJ45 type cables. (**Note:** Please refer to the LED Indicator Section for LAN LED information.)

LAN Ports Pin Definition			
Pin#	Definition		
1	P2V5SB	10	SGND
2	TD0+	11	Act LED
3	TD0-	12	P3V3SB
4	TD1+	13	Link 100 LED (Yellow, +3V3SB)
5	TD1-	14	Link 1000 LED (Yellow, +3V3SB)
6	TD2+	15	Ground
7	TD2-	16	Ground
8	TD3+	17	Ground
9	TD3-	18	Ground

(NC: No Connection)

1. LAN1
2. LAN2
3. IPMI LAN

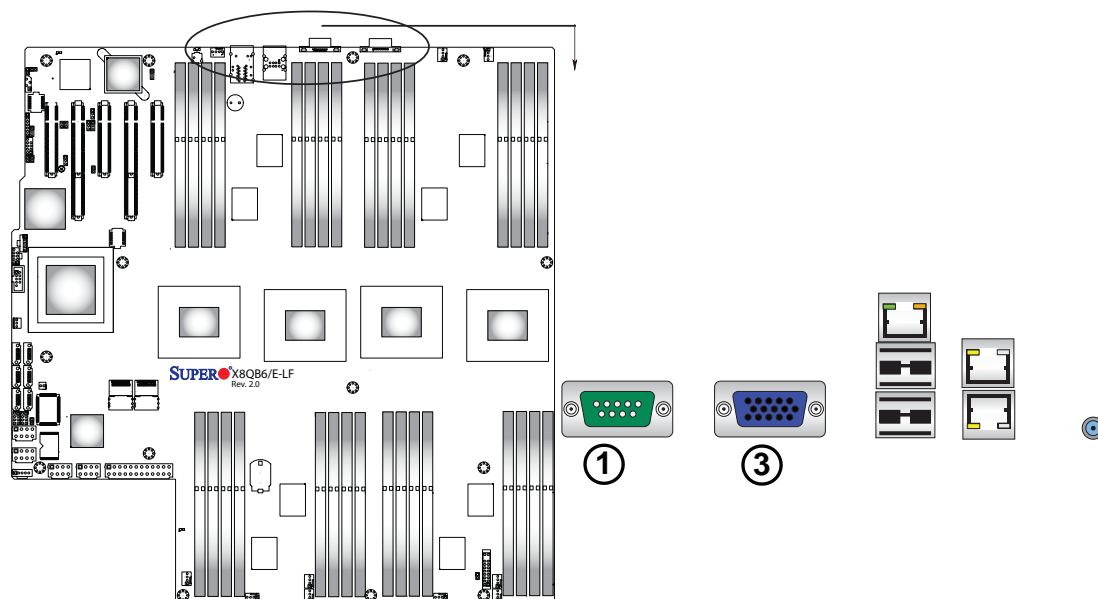

Unit Identifier Switch

A Unit Identifier (UID) Switch and two LED Indicators are located on the motherboard. The UID Switch is located next to the LAN ports on the backplane. The Rear UID LED (LED26) is located next to the UID Switch. The Front Panel UID LED is located at Pins 7/8 of the Front Control Panel at JF1. Connect a cable to Pin 8 on JF1 for Front Panel UID LED indication. When you press the UID switch, both Rear UID LED and Front Panel UID LED Indicators will be turned on. Press the UID switch again to turn off both LED Indicators. These UID Indicators provide easy identification of a system unit that may be in need of service.

UID Switch	
Pin#	Definition
1	Ground
2	Ground
3	Button In
4	Ground

UID LED (LED26) Status		
Color/State	OS	Status
Blue: On	Windows OS	Unit Identified
Blue: Blinking	Linux OS	Unit Identified

 **Note:** UID can also be triggered via IPMI on the motherboard. For more information on IPMI, please refer to the IPMI User's Guide posted on our Website @<http://www.supermicro.com>.

1. UID Switch
2. Rear UID LED (LED26)
3. Front UID LED

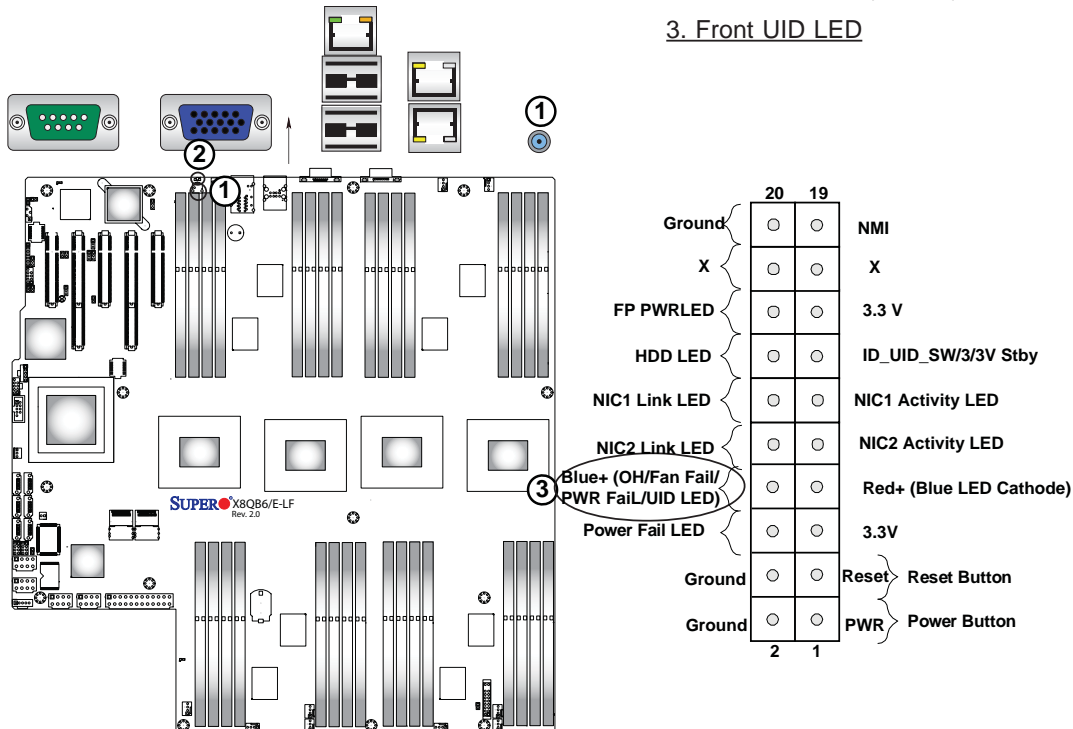

Front Control Panel

JF1 contains header pins for various buttons and indicators that are normally located on a control panel at the front of the chassis. These connectors are designed specifically for use with Supermicro's server chassis. See the figure below for the descriptions of the various control panel buttons and LED indicators. Refer to the following section for descriptions and pin definitions.

JF1 Header Pins

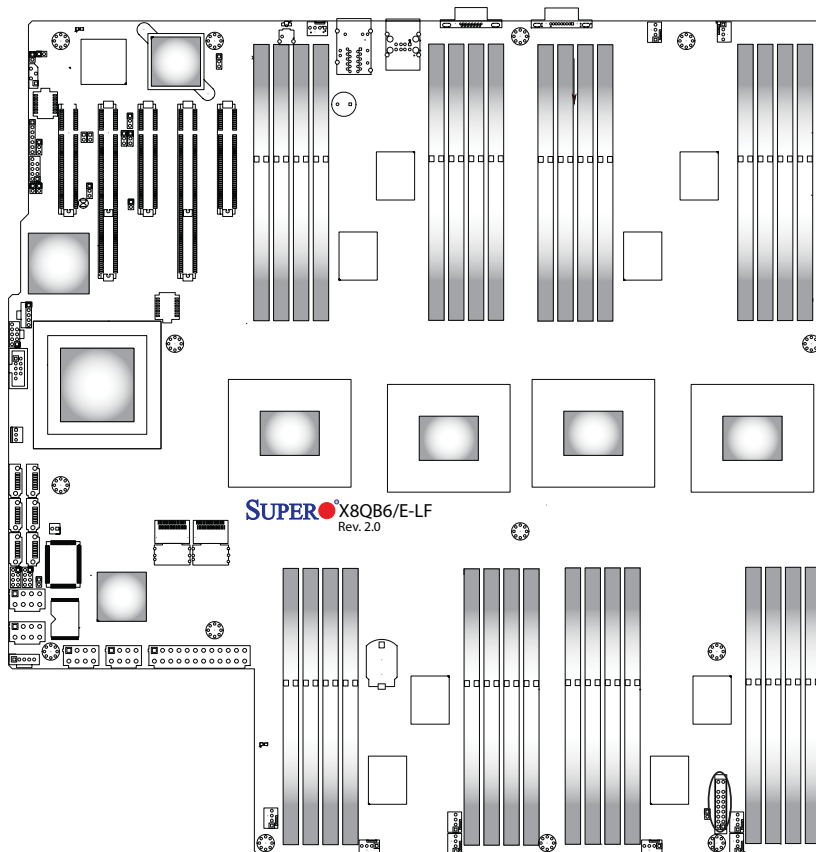

	20	19	
Ground	○	○	NMI
X	○	○	X
FP PWRLED	○	○	3.3 V
HDD LED	○	○	ID_UID_SW/3/3V Stby
NIC1 Link LED	○	○	NIC1 Activity LED
NIC2 Link LED	○	○	NIC2 Activity LED
Blue+ (OH/Fan Fai/ PWR FaiL/UID LED)	○	○	Red+ (Blue LED Cathode)
Power Fail LED	○	○	3.3V
Ground	○	○	Reset } Reset Button
Ground	○	○	PWR } Power Button
	2	1	

Front Control Panel Pin Definitions

NMI Button

The non-maskable interrupt button header is located on pins 19 and 20 of JF1. Refer to the table on the right for pin definitions.

NMI Button Pin Definitions (JF1)	
Pin#	Definition
19	Control
20	Ground

Power LED

The Power LED connection is located on pins 15 and 16 of JF1. Refer to the table on the right for pin definitions.

Power LED Pin Definitions (JF1)	
Pin#	Definition
15	3.3V
16	PWR LED

A. NMI

B. PWR LED

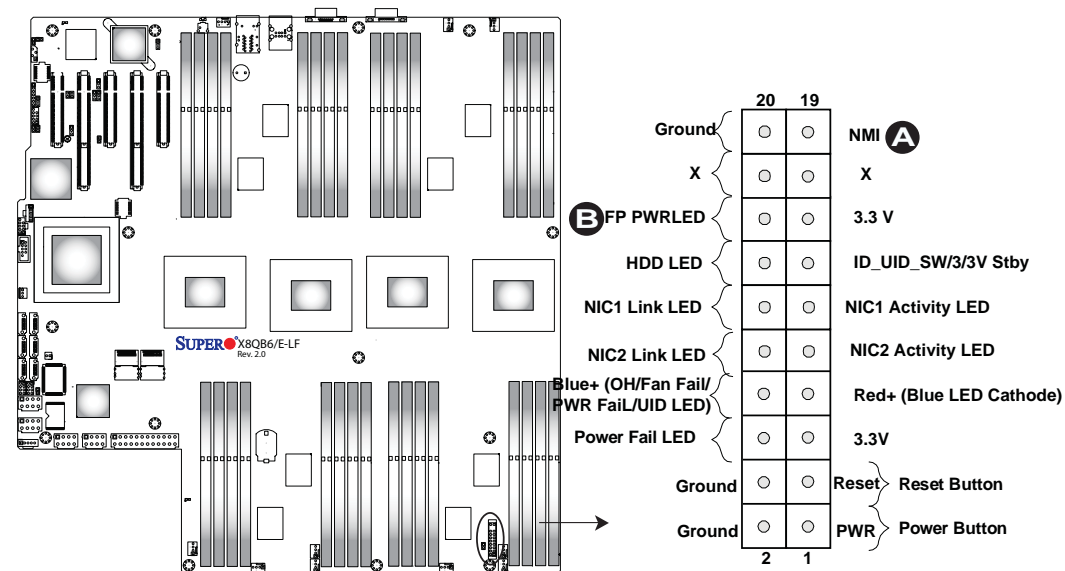

HDD LED

The HDD LED connection is located on pins 13 and 14 of JF1. Attach a cable here to indicate HDD activity. See the table on the right for pin definitions.

HDD LED Pin Definitions (JF1)	
Pin#	Definition
13	3.3V Standby
14	HD Active

NIC1/NIC2 LED Indicators

The NIC (Network Interface Controller) LED connection for GLAN port 1 is located on pins 11 and 12 of JF1, and the LED connection for GLAN Port 2 is on Pins 9 and 10. Attach the NIC LED cables here to display network activity. Refer to the table on the right for pin definitions.

GLAN1/2 LED Pin Definitions (JF1)	
Pin#	Definition
9	NIC 2 Activity LED
10	NIC 2 Link LED
11	NIC 1 Activity LED
12	NIC 1 Link LED

- A. HDD LED
- B. NIC1 Link LED
- C. NIC1 Activity LED
- D. NIC2 Link LED
- E. NIC2 Activity LED

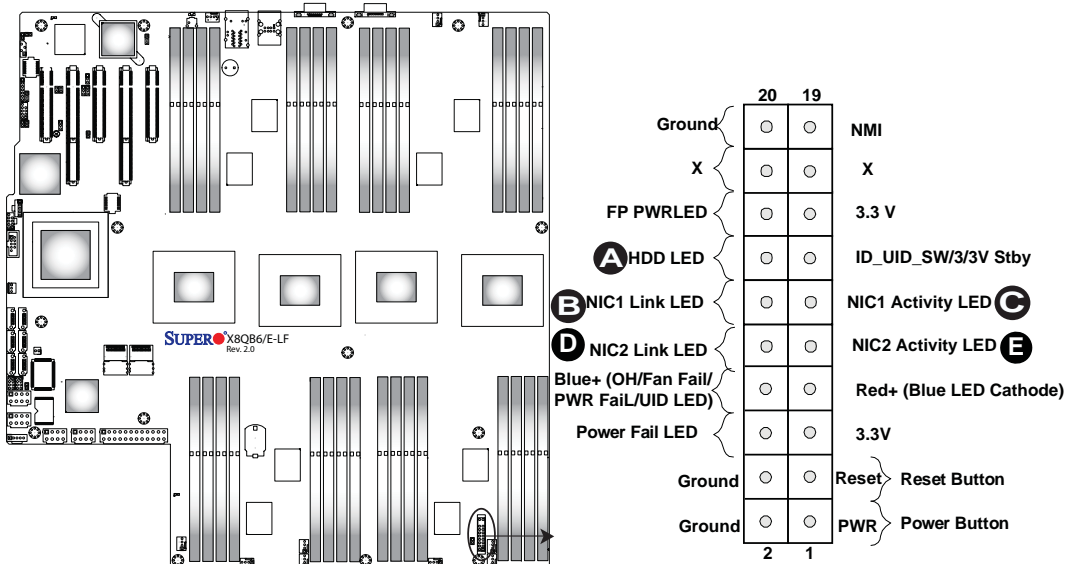

Overheat (OH)/Fan Fail/PWR Fail/UID LED

Connect an LED cable to OH/Fan Fail/Front UID LED connection on pins 7 and 8 of JF1 to provide advanced warnings of chassis overheat or fan failure. It also works as the front panel UID LED indicator. The Red LED takes precedence over the Blue LED by default. Refer to the table on the right for pin definitions.

OH/Fan Fail/PWR Fail/UID LED Pin Definitions (JF1)	
Pin#	Definition
7	Red+ (Blue LED Cathode)
8	Blue+ (OH/Fan Fail/PWR Fail/UID LED)

OH/Fan Fail Indicator Status	
State	Definition
Off	Normal
On	Overheat
Flashing	Fan Fail

Power Fail LED

The Power Fail LED connection is located on pins 5 and 6 of JF1. Refer to the table on the right for pin definitions.

PWR Fail LED Pin Definitions (JF1)	
Pin#	Definition
5	3.3V
6	PWR Supply Fail

- A. Blue LED Cathode
- B. OH/Fail/PWR Fail LED (Red)/UID (Blue)
- C. PWR Supply Fail

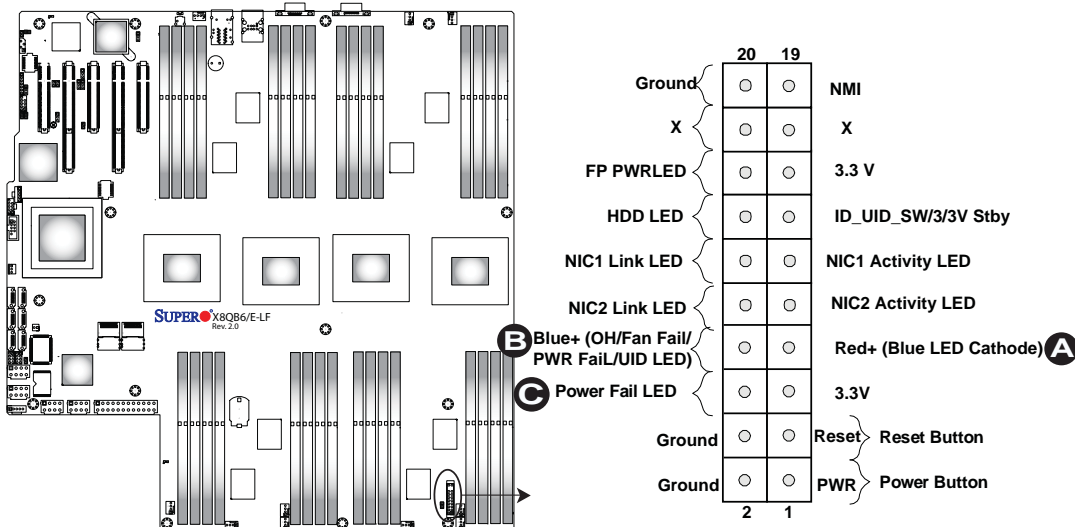

Reset Button

The Reset Button connection is located on pins 3 and 4 of JF1. Attach it to a hardware reset switch on the computer case. Refer to the table on the right for pin definitions.

Reset Button Pin Definitions (JF1)	
Pin#	Definition
3	Reset
4	Ground

Power Button

The Power Button connection is located on pins 1 and 2 of JF1. Momentarily contacting both pins will power on/off the system. This button can also be configured to function as a suspend button (with a setting in the BIOS - See Chapter 5). To turn off the power when the system is in suspend mode, press the button for 4 seconds or longer. Refer to the table on the right for pin definitions.

Power Button Pin Definitions (JF1)	
Pin#	Definition
1	Signal
2	Ground

A. Reset Button

B. PWR Button

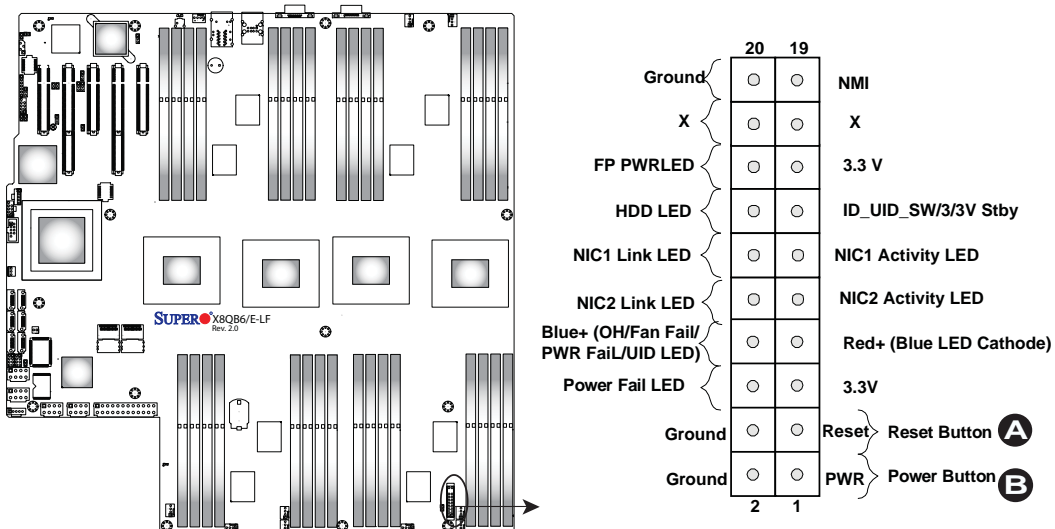

3-6 Connecting Cables

Power Connectors

A 24-pin main power supply connector(JPWR3) and four 8-pin CPU PWR connectors (JPWR1~2, JPWR4~5) are located on the motherboard. These power connectors meet the SSI EPS 12V specification. These power connectors must also be connected to your power supply. See the table on the right for pin definitions.

Warning: To provide adequate power supply to the motherboard, be sure to connect the 24-pin ATX PWR (JPWR3) and *three* 8-pin PWR connectors (JPWR1, JPWR2, JPWR4, or JPWR5) to the power supply. Failure to do so will void the manufacturer warranty on your power supply and motherboard. Also, be sure to use a power supply that supports the specifications listed in the table on Page 2-3 or Page 2-6.

ATX Power 24-pin Connector Pin Definitions			
Pin#	Definition	Pin #	Definition
13	+3.3V	1	+3.3V
14	-12V	2	+3.3V
15	COM	3	COM
16	PS_ON	4	+5V
17	COM	5	COM
18	COM	6	+5V
19	COM	7	COM
20	Res (NC)	8	PWR_OK
21	+5V	9	5VSB
22	+5V	10	+12V
23	+5V	11	+12V
24	COM	12	+3.3V

12V 8-pin PWR Connector Pin Definitions	
Pins	Definition
1 through 4	Ground
5 through 8	+12V

(Required)

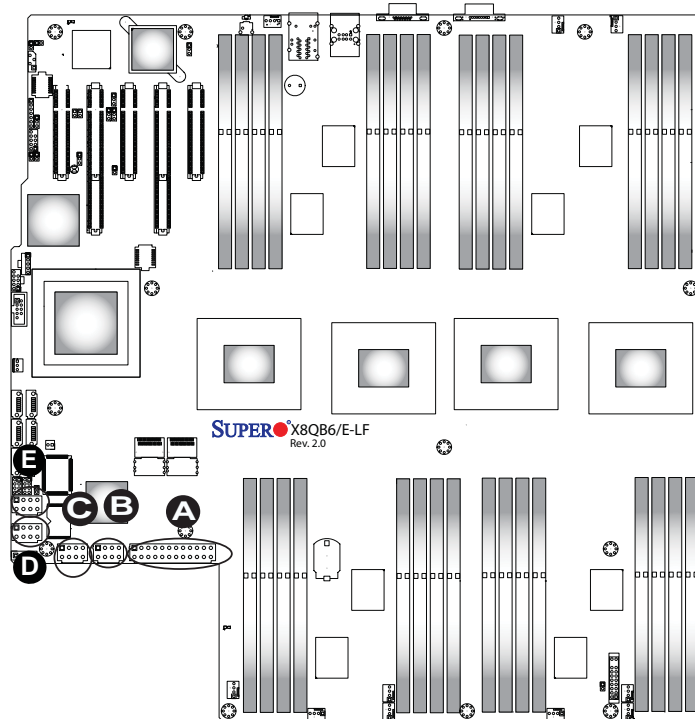

- A. JPWR3: 24-pin ATX PWR (Req'd)
- B. JPWR1: 8-pin Processor PWR (Req'd)
- C. JPWR2: 8-pin Processor PWR (Req'd)
- D. JPWR4: 8-pin Processor PWR (Req'd)
- E. JPWR5: 8-pin Processor PWR (Req'd)

Fan Headers

This motherboard has 11 system/CPU fan headers (Fan 1 to Fan11) on the motherboard. All these 4-pin fan headers are backward compatible with the traditional 3-pin fans. However, fan speed control is available for 4-pin fans only. The fan speeds are controlled by Thermal Management via Hardware Monitoring in the Advanced Setting in the BIOS. (See Chapter 5 for more details.) See the table on the right for pin definitions.

Fan Header Pin Definitions	
Pin#	Definition
1	Ground
2	+12V
3	Tachometer
4	PWR Modulation

Chassis Intrusion

A Chassis Intrusion header is located at JL1 on the motherboard. Attach an appropriate cable from the chassis to inform you of a chassis intrusion when the chassis is opened.

Chassis Intrusion Pin Definitions	
Pin#	Definition
1	Intrusion Input
2	Ground

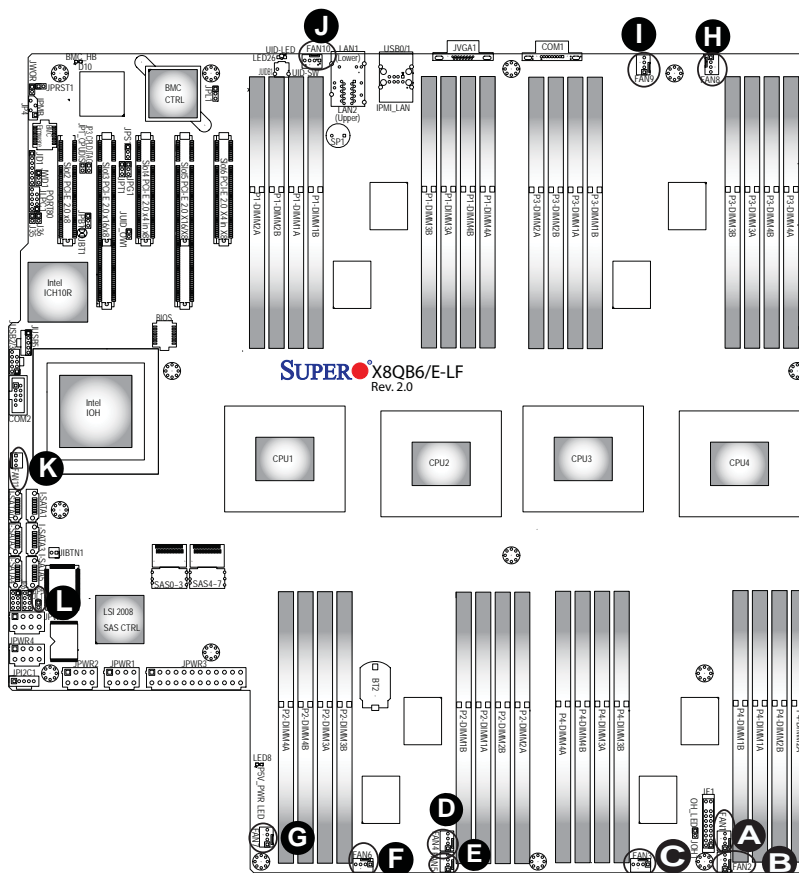

- A. Fan 1
- B. Fan 2
- C. Fan 3
- D. Fan 4
- E. Fan 5
- F. Fan 6
- G. Fan 7
- H. Fan 8
- I. Fan 9
- J. Fan 10
- K. Fan 11
- L. Chassis Intrusion

Internal Speaker

The Internal Speaker, located at SP1, can be used to provide audible indications for various beep codes. See the table on the right for pin definitions. Refer to the layout below for the locations of the Internal Buzzer (SP1).

Internal Buzzer (SP1) Pin Definition		
Pin#	Definitions	
Pin 1	Pos. (+)	Beep In
Pin 2	Neg. (-)	Alarm Speaker

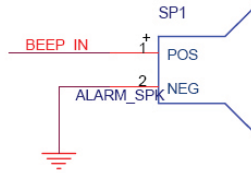

Power LED/Speaker

On the JD1 header, pins 1-3 are used for power LED indication, and pins 4-7 are for the speaker. See the tables on the right for pin definitions. Please note that the speaker connector pins (4-7) are used with an external speaker. If you wish to use the onboard speaker, you should close pins 6-7 with a jumper.

PWR LED Connector Pin Definitions	
Pin Setting	Definition
Pin 1	Anode (+)
Pin2	Cathode (-)
Pin3	NA

Speaker Connector Pin Settings	
Pin Setting	Definition
Pins 4-7	External Speaker
Pins 6-7	Internal Speaker

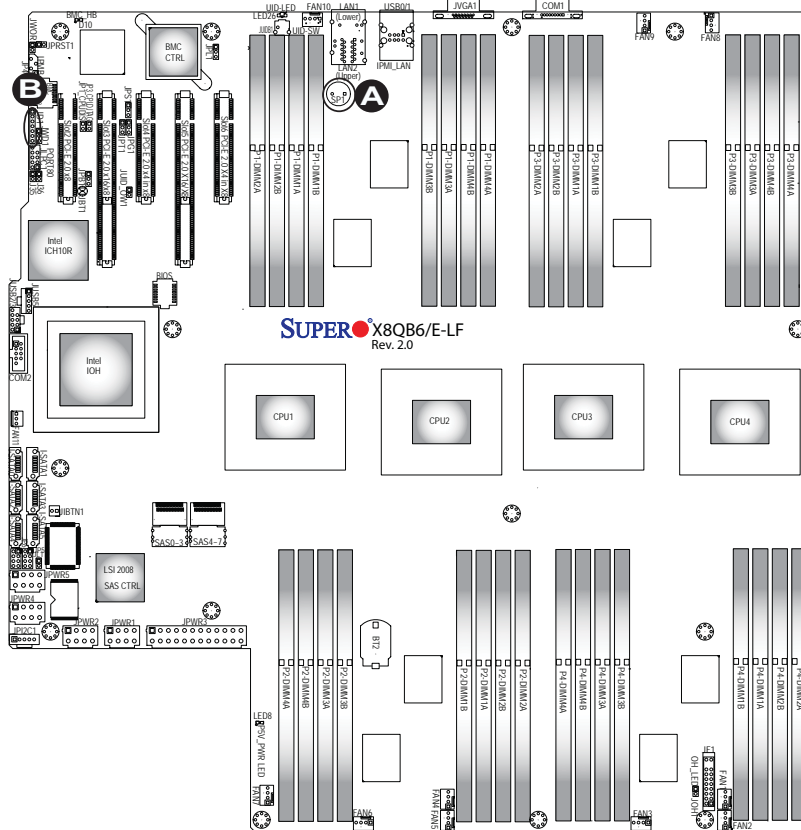

- A. Internal Speaker (Buzzer)
- B. PWR LED/Speaker

LPCI Port 80

An LPCI (Low-Profile PCI) Port 80 header is located at JLPC1 to provide Port 80 connection. Use this header to enhance system performance and data security. See the table on the right for pin definitions.

LPCI Port 80 Header Pin Definitions			
Pin #	Definition	Pin #	Definition
1	LCLK	2	GND
3	LFRAME#	4	<(KEY)>
5	LRESET#	6	+5V (X)
7	LAD 3	8	LAD 2
9	+3.3V	10	LAD1
11	LAD0	12	GND
13	SMB_CLK4	14	SMB_DAT4
15	+3V_DUAL	16	SERIRQ
17	GND	18	CLKRUN# (X)
19	LPCPD#	20	LDRQ# (X)

Overheat LED/Fan Fail

The JOH1 header is used to connect an LED indicator to provide warnings of chassis overheating and fan failure. This LED will blink when a fan failure occurs. Refer to the tables on right for pin definitions.

Overheat LED Pin Definitions	
Pin#	Definition
1	5vDC
2	OH Active

OH/Fan Fail LED Status	
State	Message
Solid	Overheat
Blinking	Fan Fail

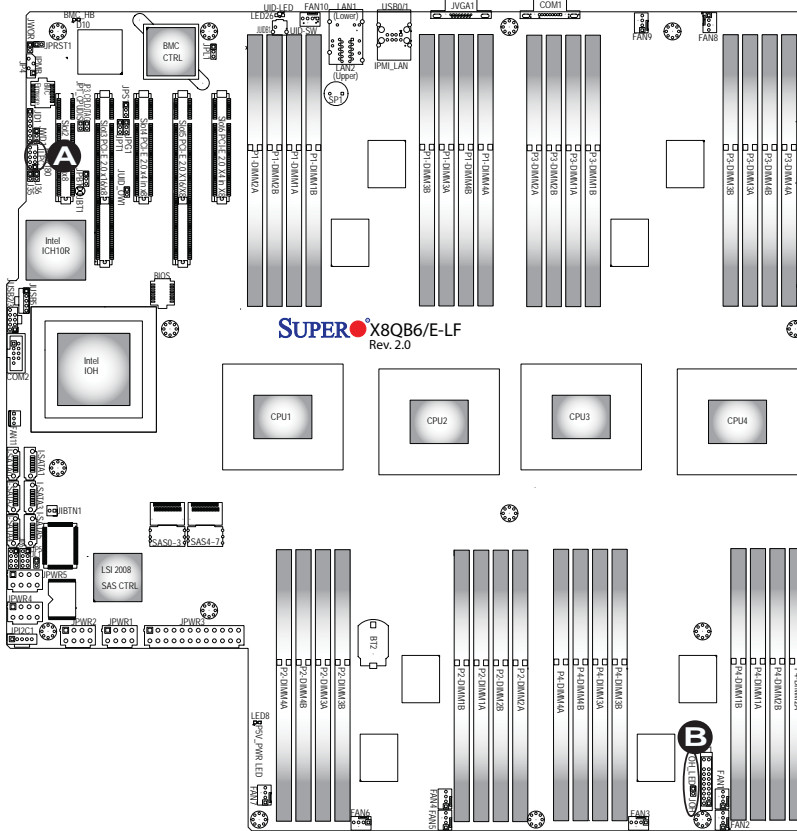

A. LPCI Port 80 Header
B. Overheat LED

Power SMB (I²C) Connector

Power System Management Bus (I²C) Connector (JPI²C1) monitors power supply, fan and system temperatures. See the table on the right for pin definitions.

PWR SMB Pin Definitions	
Pin#	Definition
1	Clock
2	Data
3	PWR Fail
4	Ground
5	+3.3V

IPMB

A System Management Bus header for IPMI 2.0 is located at JP4. Connect the appropriate cable here to use the IPMB I²C connection on your system.

IPMB Header Pin Definitions	
Pin#	Definition
1	Data
2	Ground
3	Clock
4	No Connection

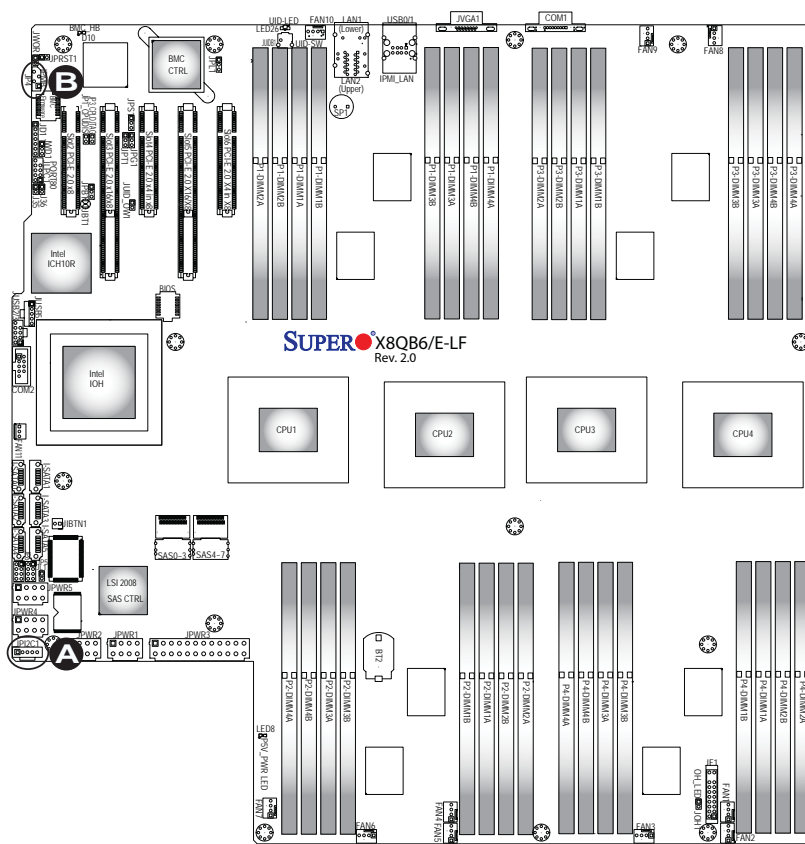

- A. JPI²C1
- B. IPMB (JP4)

T-SGPIO 1/2 Headers

Two SGPIO (Serial Link General Purpose Input/Output) headers are located at JP5/JP6 on the motherboard. These headers support Serial Link interface for onboard SATA connections. See the table on the right for pin definitions.

T-SGPIO Pin Definitions			
Pin#	Definition	Pin	Definition
1	NC	2	NC
3	Ground	4	Data
5	Load	6	Ground
7	Clock	8	NC

Note: NC= No Connection

Wake-On-Ring

The Wake-On-Ring header is located at JWOR. This function allows your computer to wake up when receiving an incoming call to the modem while in the suspend state. See the table on the right for pin definitions. You must have a Wake-On-Ring card and a cable to use this feature.

Wake-On-Ring Pin Definitions	
Pin#	Definition
1	Ground
2	Wake-up

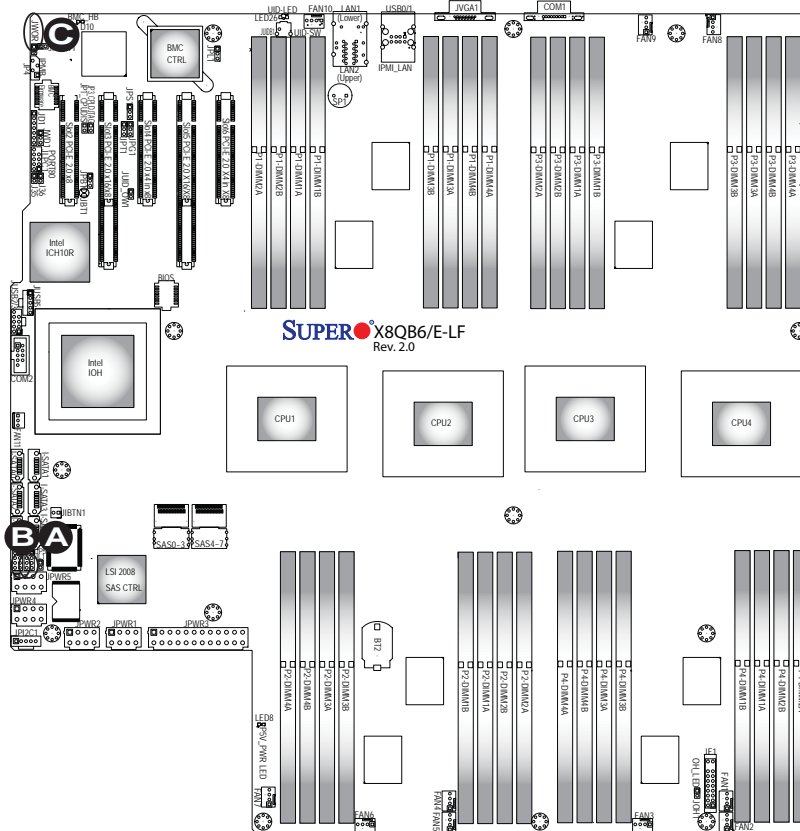

- A. T-SGPIO1
- B. T-SGPIO2
- C. Wake-On-Ring

Unit Identification Switch/LED

A Unit Identifier switch (UID) and a rear UID LED indicator (LED26) are located next to Fan10 on the back of the chassis. When the user pushes the rear UID switch, the rear UID LED (LED26) will be turned on. Push the UID switch again to turn off the LED indicator. The UID switch provides easy identification of a system unit that may be in need of service. See the tables on the right for more information.

UID Switch (UID) Pin Definitions	
Pin#	Definition
1	Ground
2	Ground
3	Button In
4	Ground

UID LED Status		
Color/State	OS	Status
Blue: On	Windows OS	Unit Identified
Blue: Blinking	Linux OS	Unit Identified

RAIDKey Header (Optional for X8QB6-LF only)

A RAIDKey header, located at JIBTN1, provides RAID function support to enhance system performance.

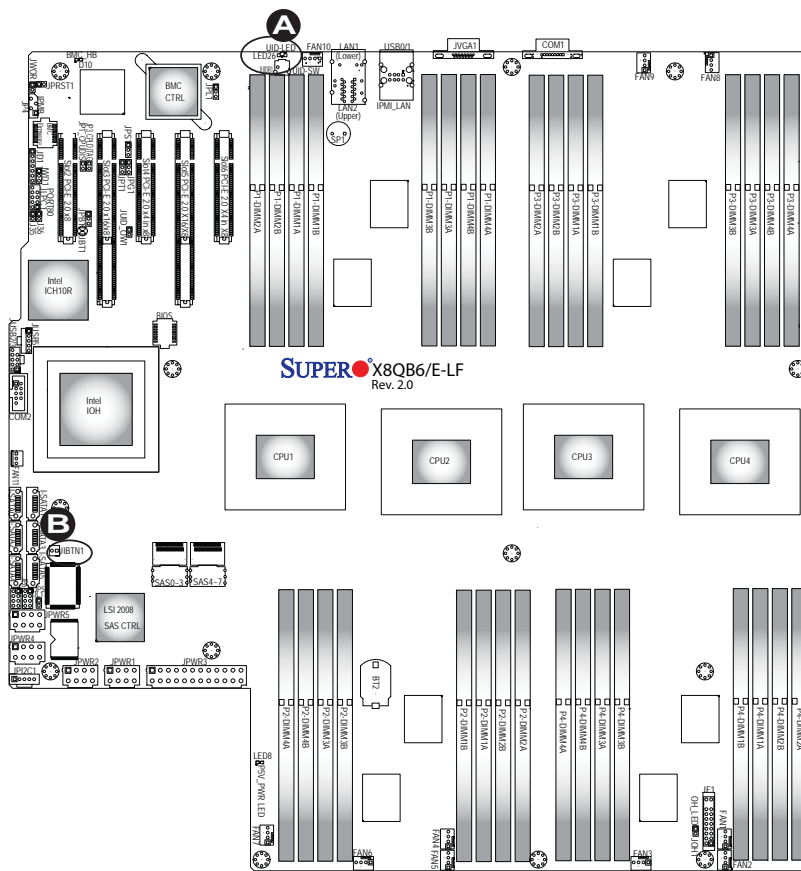

A. UID Switch & UID LED

B. RAIDKey (Optional for X8QB6-LF only)

3-7 Jumper Settings

Explanation of Jumpers

To modify the operation of the motherboard, jumpers can be used to choose between optional settings. Jumpers create shorts between two pins to change the function of the connector. Pin 1 is identified with a square solder pad on the printed circuit board. See the motherboard layout pages for jumper locations.

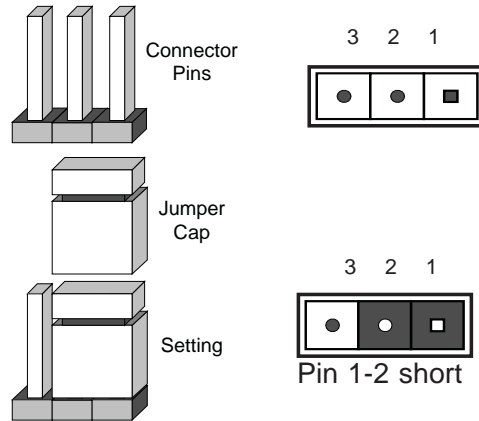

Note: On two pin jumpers, "Closed" means the jumper is on and "Open" means the jumper is off the pins.

GLAN Enable/Disable

JPL1 enables or disables the GLAN Port1/GLAN Port2 on the motherboard. See the table on the right for jumper settings. The default setting is Enabled.

GLAN Enable Jumper Settings	
Jumper Setting Definition	
1-2	Enabled (default)
2-3	Disabled

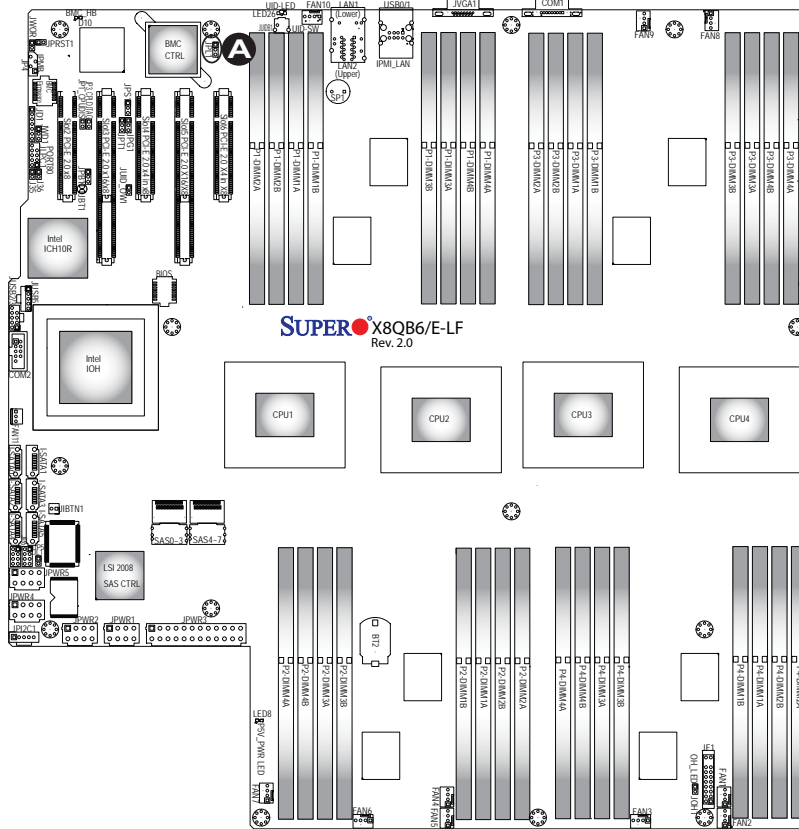

A. GLAN Ports Enable

CMOS Clear

JBT1 is used to clear CMOS. Instead of pins, this "jumper" consists of contact pads to prevent accidental clearing of CMOS. To clear CMOS, use a metal object such as a small screwdriver to touch both pads at the same time to short the connection. Always remove the AC power cord from the system before clearing CMOS. ⚠

 **Note 1.** For an ATX power supply, you must completely shut down the system, remove the AC power cord, and then short JBT1 to clear CMOS.

Note 2. Be sure to remove the onboard CMOS Battery before you short JBT1 to clear CMOS.

Note 3. Clearing CMOS will also clear all passwords.

Watch Dog Enable/Disable

Watch Dog (JWD1) is a system monitor that can reboot the system when a software application hangs. Close Pins 1-2 to reset the system if an application hangs. Close Pins 2-3 to generate a non-maskable interrupt signal for the application that hangs. See the table on the right for jumper settings. Watch Dog must also be enabled in the BIOS.

Watch Dog Jumper Settings	
Jumper Setting	Definition
Pins 1-2	Reset (default)
Pins 2-3	NMI
Open	Disabled

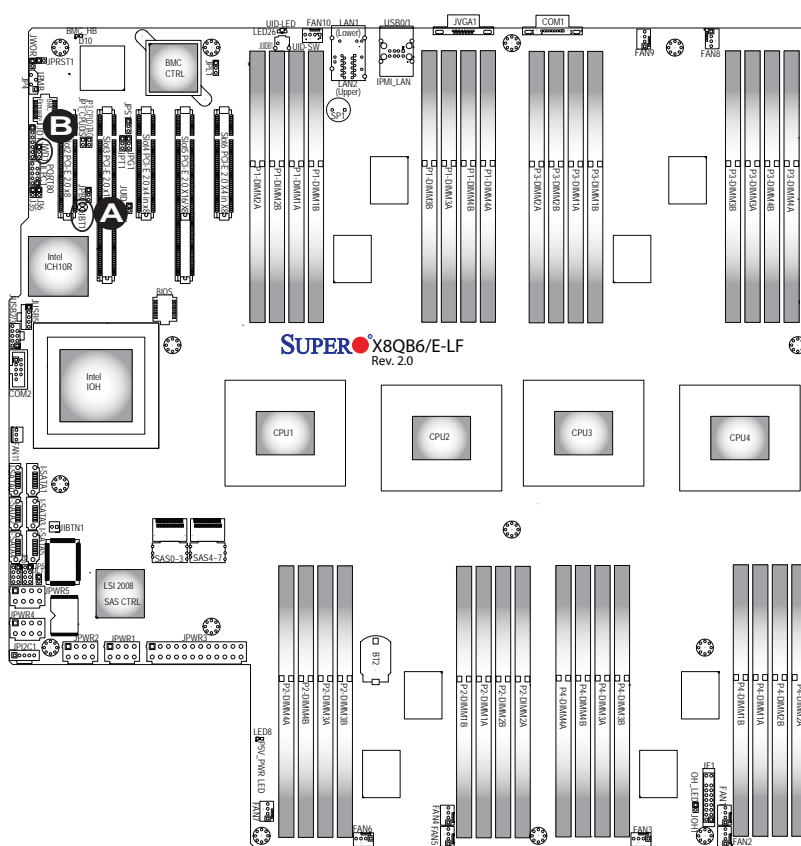

- A. Clear CMOS
- B. Watch Dog Enable

VGA Enable

Jumper JPG1 allows the user to enable the onboard VGA connectors. The default setting is 1-2 to enable the connection. See the table on the right for jumper settings.

VGA Enable Jumper Settings	
Jumper Setting	Definition
1-2	Enabled (Default)
2-3	Disabled

TPM Support Enable

JPT1 allows the user to enable TPM (Trusted Platform Modules) support to enhance data integrity and system security. See the table on the right for jumper settings. The default setting is enabled.

TPM Support Enable Jumper Settings	
Jumper Setting	Definition
1-2	Enabled
2-3	Disabled



Note: For more information on IPMI configuration, please refer to the WPCM 450 IPMI BMC User's Guide posted on our website @ <http://www.supermicro.com>.

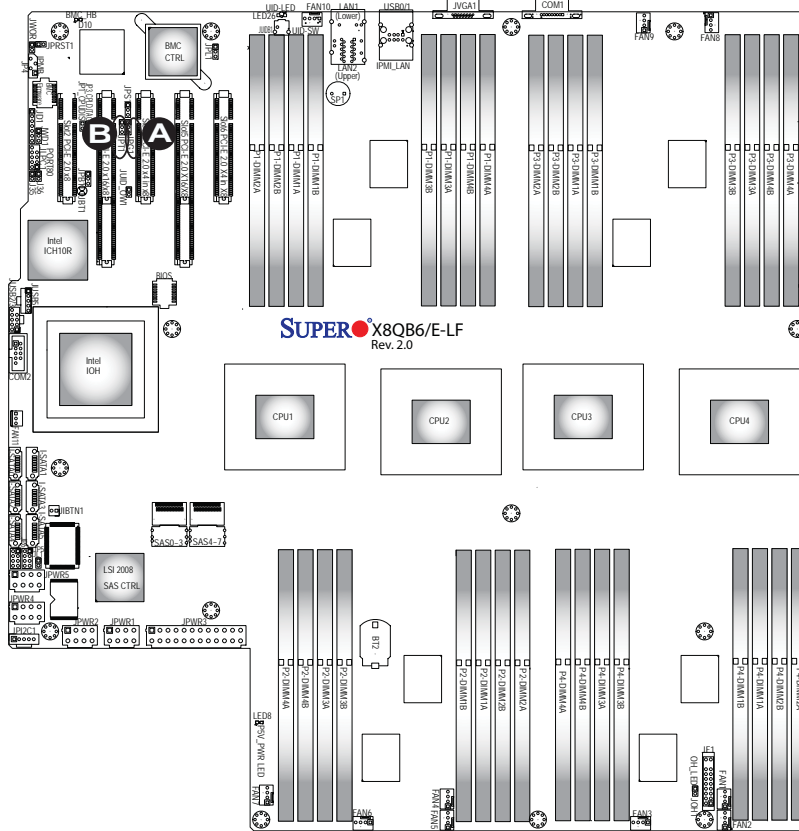

A. VGA Enabled
B. TPM Enabled

SAS2 Enable (X8QB6-LF only)

Close pins 1-2 of JPS1 to enable SAS2 (Serial_Attached_SCSI) support on the X8QB6-LF motherboard. See the table on the right for jumper settings. The default setting is enabled.

SAS2 Enable Jumper Settings	
Jumper Setting	Definition
1-2	Enabled (Default)
2-3	Disabled

BMC Enable

Jumper JPB1 allows you to enable the embedded WPCM 450 BMC (Baseboard Management) Controller to provide IPMI 2.0/KVM support on the motherboard. See the table on the right for jumper settings.

BMC Enable Jumper Settings	
Jumper Setting	Definition
Pins 1-2	BMC Enable
Pins 2-3	Normal (Default)

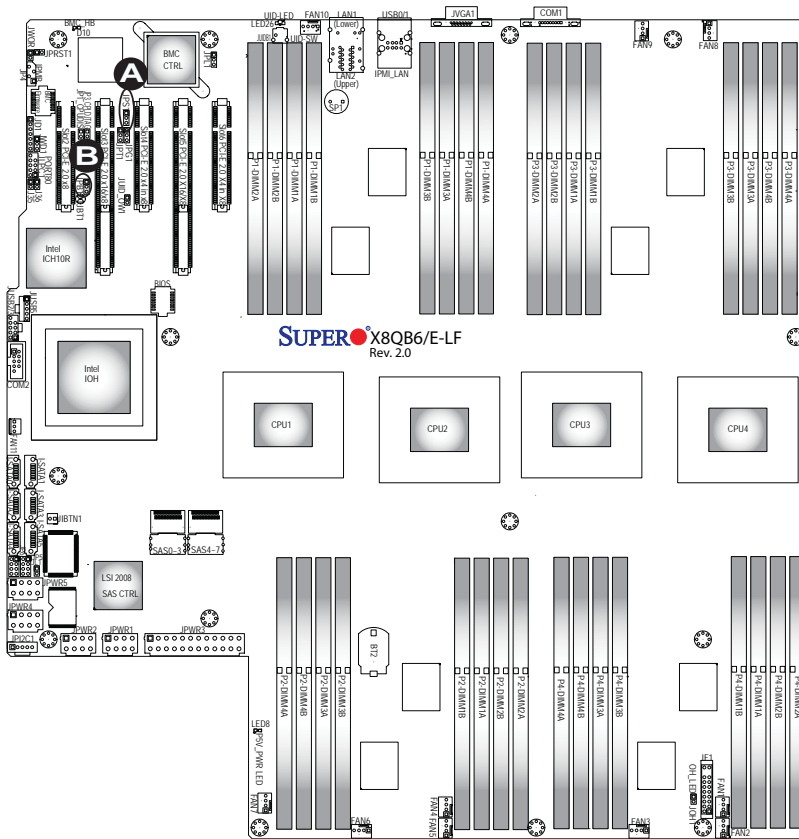

- A. SAS2 Enabled
- B. BMC Enabled

BMC Reset

Use Jumper JPRST1 to reset the BMC settings on the motherboard. See the table on the right for jumper settings.

BMC Reset Jumper Settings	
Jumper Setting	Definition
Closed	BMC Reset
Open	Normal (Default)

J_UID_OW (-Overwriting)

When the jumper J_UID_OW is set to Off (default), the Red LED (Overheat/Fan Fail/PWR Fail/UID LED) located on Pin 8 of the Front Control Panel (JF1) will take precedence over the Blue UID_LED located on Pin 7 of JF1. In this case, when the Red LED is on, the Blue LED will be turned off. When the RED LED is off, the Blue UID_LED can be on or off. In other words, the Red LED signal overwrites the Blue UID_LED signal if J_UID-OW is set to off. When the jumper J_UID_OW is On, the Red LED (OH/Fan Fail/PWR Fail/UID LED) and the Blue_UID_LED work independently. The Red LED will have no effects on the Blue LED. See the table on the right for jumper settings.

J_UID-OW (-Overwriting) Jumper Settings	
Jumper	Definition
Off (Default)	Red OH/Fan Fail/PWR Fail LED (Pin 8 of JF1) takes precedence over (overwrites) the Blue UID_LED (Pin 7 of JF1). Red LED: On, Blue LED: Off, Red LED: Off, Blue LED: On or Off
On	Red LED (OH/Fan Fail/PWR Fail LED) and the Blue UID_LED function independently. Red LED does not overwrite the Blue LED. The Red LED has no effects on the Blue_UID_LED Red LED: On, Blue LED: On, Off Red LED: Off, Blue LED: On, Off

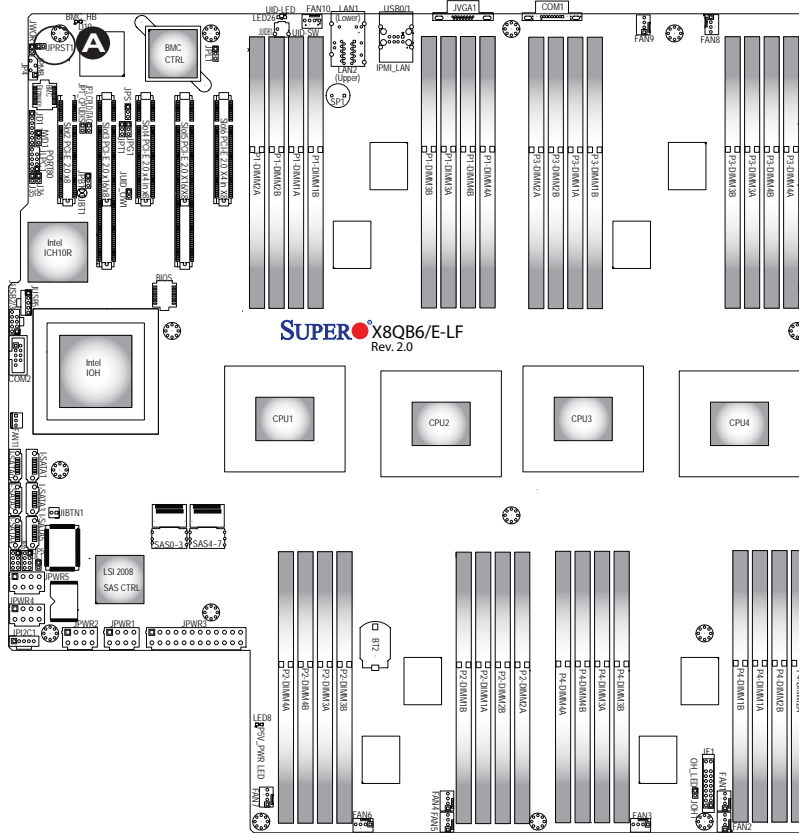

A. BMC Reset

ME Recovery

J36 (JPME2) is used for ME Firmware Recovery mode, which will limit system resource for essential function use only without putting restrictions on power use. In single operation mode, online upgrade will be available via Recovery mode. See the table on the right for jumper settings.

ME Recovery Pin Definitions	
Pin#	Definition
1	No Connection
2	Signal
3	Ground

Manufacturer Mode Select

Close Jumper (J35: JPME1) to bypass SPI flash security and force the system to use the Manufacturer mode which will allow the user to flash the system firmware from a host server to modify system settings. See the table on the right for jumper settings.

ME Mode Select Jumper Settings	
Jumper Setting	Definition
1-2	Manufacture Mode
2-3	Normal (Default)

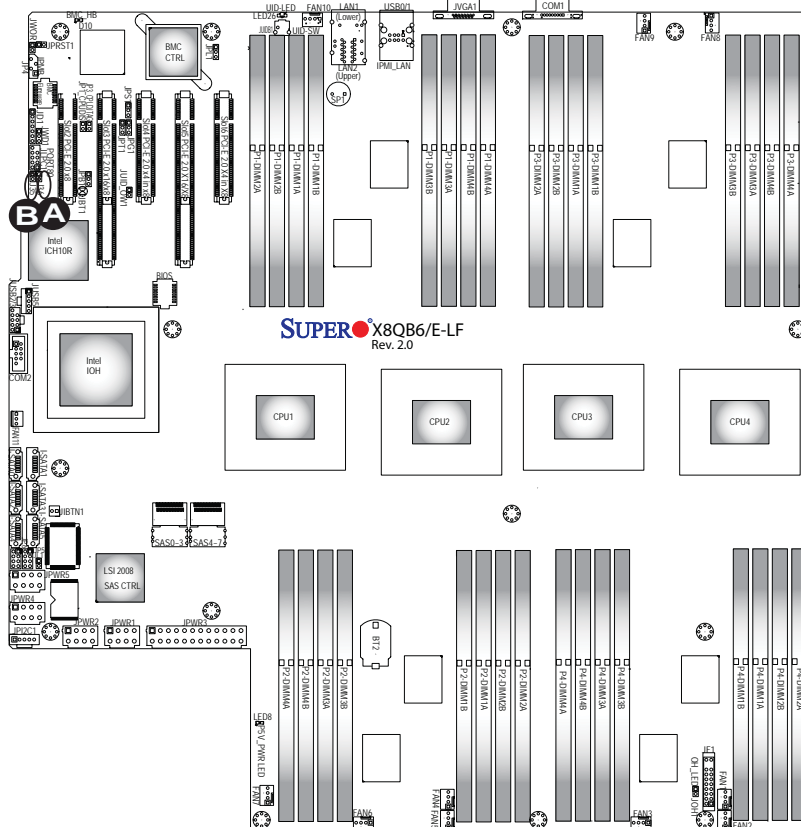

- A. J36 (JPME2)
- B. J35 (JPME1)

3-8 Onboard LED Indicators

GLAN LEDs

There are two GLAN ports on the motherboard. Each Gigabit Ethernet LAN port has two LEDs. The Yellow (Left) LED indicates activity. The Link LED on the right may be green, amber or off to indicate the speed of the connection. See the tables at right for more information.

IPMI Dedicated LAN LEDs

In addition to LAN 1/LAN 2, an IPMI Dedicated LAN is also located on the I/O Backplane of the motherboard. The amber LED on the right indicates activity, while the green LED on the left indicates the speed of the connection. See the tables at right for more information.

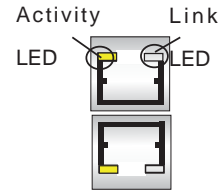

Rear View (when facing the rear side of the chassis)

GLAN Activity Indicator (Left) LED Status		
Color	Status	Definition
Yellow	Flashing	Active

GLAN Link Indicator (Right) LED Status	
LED Color	Definition
Off	No Connection or 10 Mbps
Green	100 Mbps
Amber	1 Gbps

IPMI LAN (F models only)

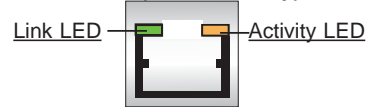

IPMI LAN Link LED (Left) & Activity LED (Right)		
	Color/State	Definition
Link (Left)	Green: Solid	100 Mbps
Activity (Right)	Amber: Blinking	Active

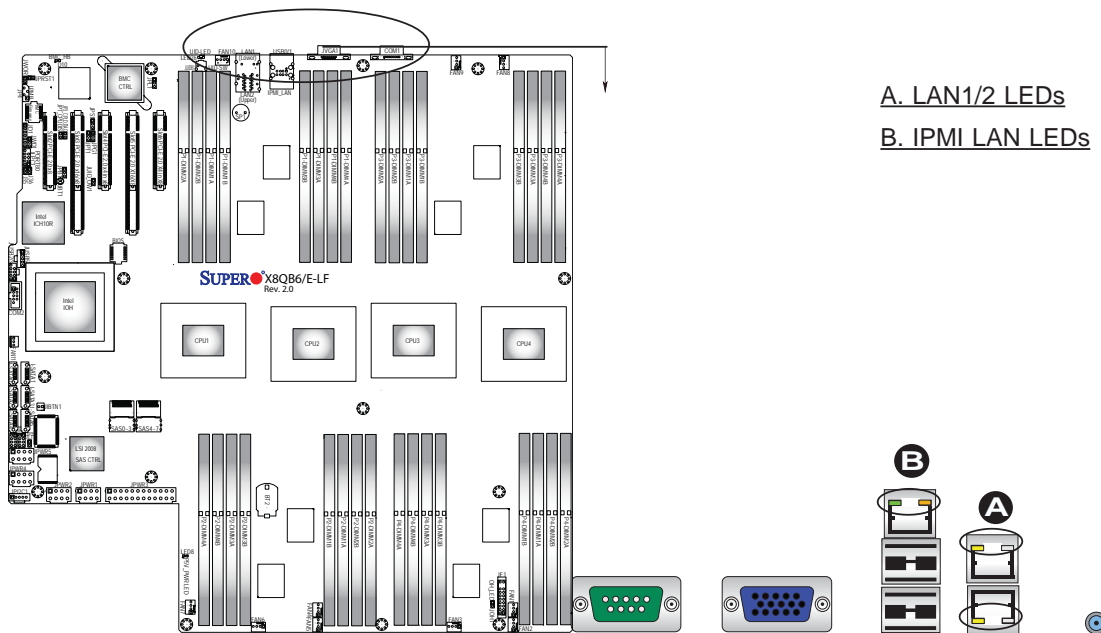

- A. LAN1/2 LEDs
- B. IPMI LAN LEDs

Rear UID LED

The rear UID LED is located at LED26 on the backplane. This LED is used in conjunction with the rear UID switch to provide easy identification of a system that might be in need of service. Refer to UID Switch on Page 3-15 for more information.

UID LED LED Status		
Color/State	OS	Status
Blue: On	Windows OS	Unit Identified
Blue: Blinking	Linux OS	Unit Identified

BMC Heartbeat LED

A BMC Heartbeat LED is located at D10 on the motherboard. When D10 is blinking, BMC functions normally. See the table at right for more information.

BMC Heartbeat LED LED Status	
Color/State	Definition
Green: Blinking	BMC: Normal

 **Note:** LED Indicators that are not documented in the manual are for testing only.

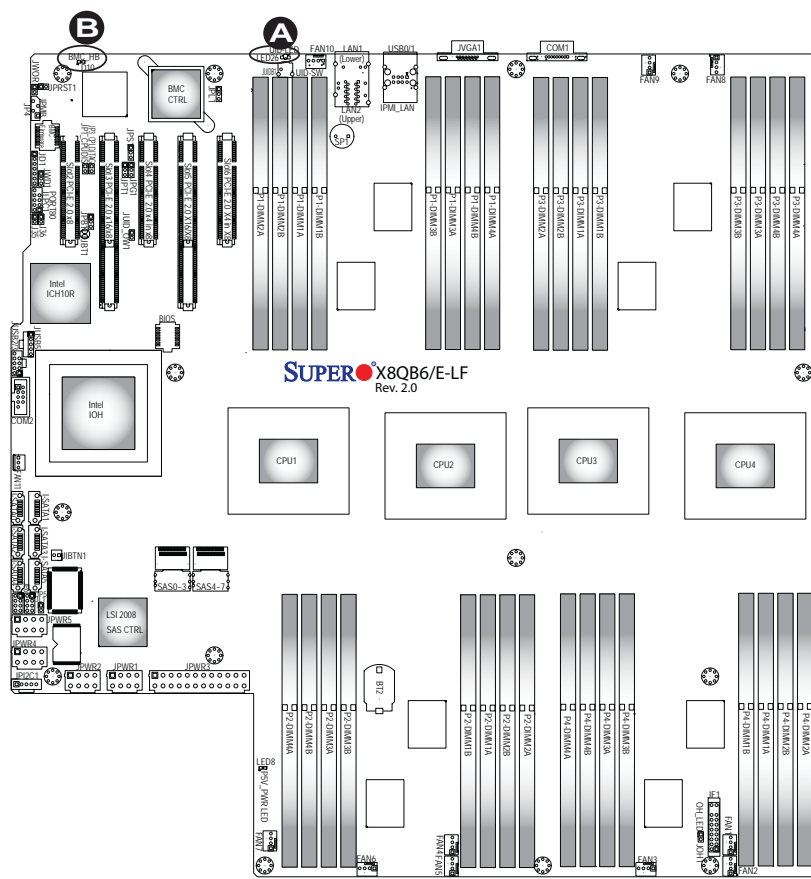

A. UID LED

B. BMC Heartbeat LED

Onboard Power LED

An Onboard 5V Standby Power LED is located at LED 8 on the motherboard. When this LED is on, the system is on. Be sure to turn off the system and unplug the power cord before removing or installing components. See the tables at right for more information.

Onboard PWR LED Indicator LED Status	
LED Color	Definition
Off	System Off (PWR cable not connected)
Green	System On
Green: Flashing Quickly	ACPI S1 State
Green: Flashing Slowly	ACPI S3 (STR) State

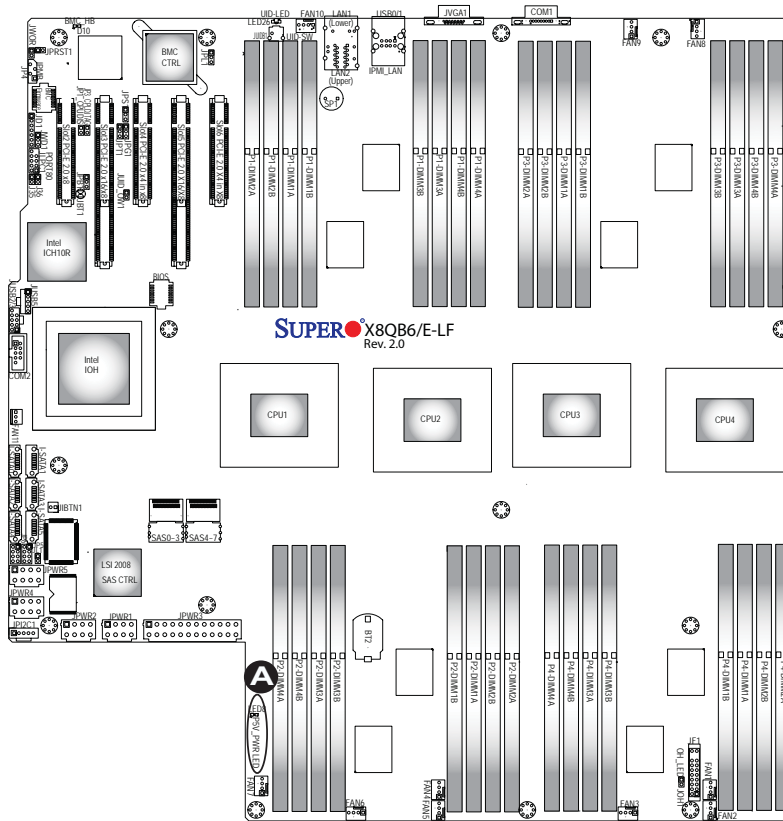

A. PWR LED

3-9 Serial ATA Connections

Serial ATA Ports

There are six Serial ATA Ports (I-SATA0~I-SATA 5) located on the motherboard. These ports, supported by the Intel ICH10R South Bridge, provide Serial Link signal connections, which are faster than the connections of Parallel ATA. See the table on the right for pin definitions.

Serial ATA/SAS2 Pin Definitions	
Pin#	Definition
1	Ground
2	TX_P
3	TX_N
4	Ground
5	RX_N
6	RX_P
7	Ground

SAS2 Ports (X8QB6-LF only)

Eight Serial_Attached_SCSI Ports (SAS 0~3, 4~7) located on the X8QB6 to provide serial link connections. These ports are supported by the LSI 2008 Controller. See the table on the right for pin definitions.



Note: For more information on SATA HostRAID configuration, please refer to the Intel SATA HostRAID User's Guide posted on our website @ <http://www.supermicro.com>..

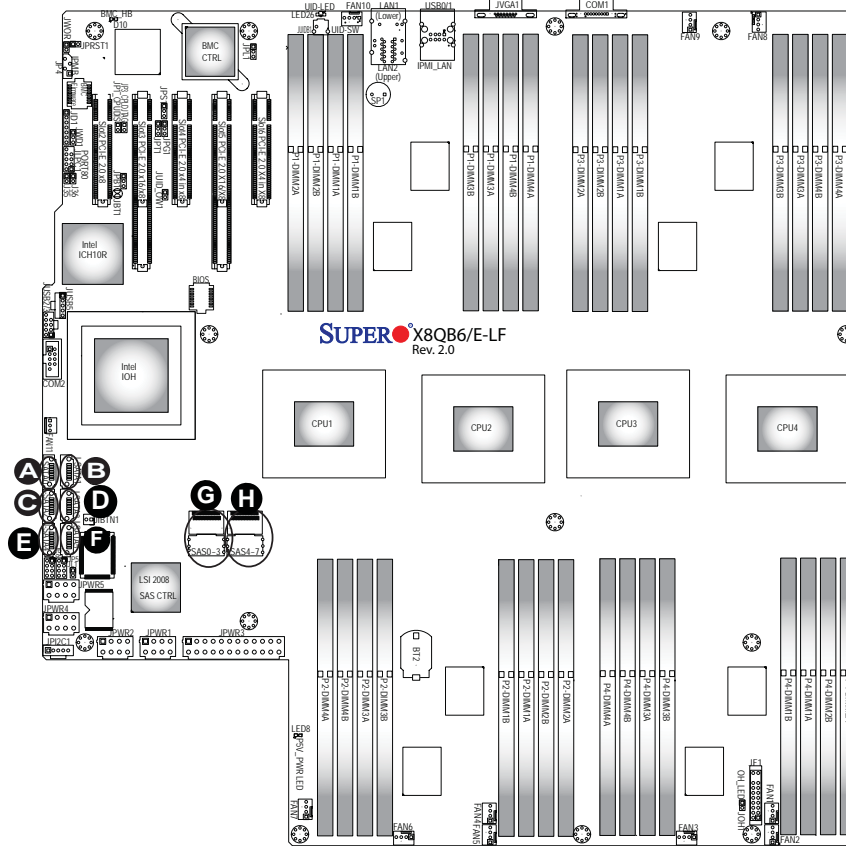

- A. I-SATA0
- B. I-SATA1
- C. I-SATA2
- D. I-SATA3
- E. I-SATA4
- F. I-SATA5
- G. SAS 0~3
- H. SAS 4~7

Chapter 4

Troubleshooting

4-1 Troubleshooting Procedures

Use the following procedures to troubleshoot your system. If you have followed all of the procedures below and still need assistance, refer to the 'Technical Support Procedures' and/or 'Returning Merchandise for Service' section(s) in this chapter. Note: Always disconnect the power cord before adding, changing or installing any hardware components.

Before Power On

1. Make sure that there are no short circuits between the motherboard and chassis.
2. Disconnect all ribbon/wire cables from the motherboard, including those for the keyboard and mouse.
3. Remove all add-on cards.
4. Install CPU 1 first (-making sure it is fully seated) and connect the front panel connectors to the motherboard.

No Power

1. Make sure that no short circuits between the motherboard and the chassis.
2. Make sure that the ATX power connectors are properly connected
3. Check that the 115V/230V switch on the power supply is properly set, if available.
4. Turn the power switch on and off to test the system, if applicable.
5. The battery on your motherboard may be old. Check to verify that it still supplies ~3VDC. If it does not, replace it with a new one.

No Video

1. If the power is on, but you have no video, remove all the add-on cards and cables.
2. Use the speaker to determine if any beep codes exist. Refer to Appendix A for details on beep codes.

System Boot Failure

If the system does not display POST or does not respond after the power is turned on, check the following:

1. Check for any error beep from the motherboard speaker.
 - If there is no error beep, try to turn on the system without DIMM modules. If there is still no error beep, try to turn on the system again with only one processor in CPU Socket#1. If there is still no error beep, replace the motherboard.
 - If there are error beeps, clear the CMOS settings by unplugging the power cord and contracting both pads on the CMOS Clear Jumper (JBT1). (Refer to Section 3-7 in Chapter 3.)
2. Remove all components from the motherboard, especially the DIMM modules. Make sure that the system's power is on, and memory error beeps are activated.
3. Turn on the system with only one DIMM module. If the system boots, check for bad DIMM modules or slots by following the Memory Errors Troubleshooting procedure in this Chapter.

Losing the System's Setup Configuration

1. Make sure that you are using a high quality power supply. A poor quality power supply may cause the system to lose the CMOS setup information. Refer to Section 2-6 for details on recommended power supplies.
2. The battery on your motherboard may be old. Check to verify that it still supplies ~3VDC. If it does not, replace it with a new one.
3. If the above steps do not fix the Setup Configuration problem, contact your vendor for repairs.

Memory Errors

When a No_Memory_Beep_Code is issued by the system, check the following:

1. Make sure that the memory modules are compatible with the system and that the DIMM modules are properly and fully installed. (For memory compatibility, refer to the Memory Compatibility Chart posted on our Website @ <http://www.supermicro.com>.)
2. Check if different speeds of DIMMs have been installed. It is strongly recommended that you use the same RAM speed for all DIMMs in the system.
3. Make sure that you are using the correct type of DDR3 Registered ECC1066/800 MHz SDRAM (recommended by the manufacturer).
4. Check for bad DIMM modules or slots by swapping a single module among all memory slots and check the results.
5. Make sure that all memory modules are fully seated in their slots. Follow the instructions given in Section 3-3 in Chapter 3.
6. Please follow the instructions given in the DIMM Population Tables listed on Page 3-8 to install your memory modules.

When the System Becomes Unstable

A. When the system becomes unstable during or after OS installation, check the following:

1. CPU/BIOS support: Make sure that your CPU is supported, and you have the latest BIOS installed in your system.
2. Memory support: Make sure that the memory modules are supported by testing the modules using memtest86 or a similar utility.

 **Note:** Refer to the product page on our website <http://www.supermicro.com> for memory and CPU support and updates.

3. HDD support: Make sure that all hard disk drives (HDDs) work properly. Replace the bad HDDs with good ones.
4. System cooling: Check system cooling to make sure that all heatsink fans, and CPU/system fans, etc., work properly. Check Hardware Monitoring settings in the BIOS to make sure that the CPU and System temperatures are

within the normal range. Also check the front panel Overheat LED, and make sure that the Overheat LED is not on.

5. Adequate power supply: Make sure that the power supply provides adequate power to the system. Make sure that all power connectors are connected. Please refer to our website for more information on minimum power requirement. Also be sure to use a power supply that supports the specifications listed in the table on Page 2-3 or Page 2-6.
6. Proper software support: Make sure that the correct drivers are used.

B. When the system becomes unstable before or during OS installation, check the following:

1. Source of installation: Make sure that the devices used for installation are working properly, including boot devices such as CD/DVD disc, CD/DVD-ROM.
2. Cable connection: Check to make sure that all cables are connected and working properly.
3. Using minimum configuration for troubleshooting: Remove all unnecessary components (starting with add-on cards first), and use minimum configuration (with a CPU and a memory module installed) to identify the trouble areas. Refer to the steps listed in Section A above for proper troubleshooting procedures.
4. Identifying bad components by isolating them: If necessary, remove a component in question from the chassis, and test it in isolation to make sure that it works properly. Replace a bad component with a good one.
5. Check and change one component at a time instead of changing several items at the same time. This will help isolate and identify the problem.
6. To find out if a component is good, swap this component with a new one to see if the system will work properly. If so, then the old component is bad. You can also install the component in question in another system. If the new system works, the component is good and the old system has problems.

4-2 Technical Support Procedures

Before contacting Technical Support, please take the following steps. Also, please note that as a motherboard manufacturer, Supermicro also sells motherboards

through its channels, so it is best to first check with your distributor or reseller for troubleshooting services. They should know of any possible problem(s) with the specific system configuration that was sold to you.

1. Please go through the 'Troubleshooting Procedures' and 'Frequently Asked Question' (FAQ) sections in this chapter or see the FAQs on our website (<http://www.supermicro.com/>) before contacting Technical Support.
2. BIOS upgrades can be downloaded from our website (<http://www.supermicro.com>).
3. If you still cannot resolve the problem, include the following information when contacting Supermicro for technical support:
 - Motherboard model and PCB revision number
 - BIOS release date/version (This can be seen on the initial display when your system first boots up.)
 - System configuration
4. An example of a Technical Support form is on our website at (<http://www.supermicro.com>).
 - Distributors: For immediate assistance, please have your account number ready when placing a call to our technical support department. We can be reached by e-mail at www.support@supermicro.com.

4-3 Frequently Asked Questions

Question: What are the various types of memory that my motherboard can support?

Answer: The motherboard supports Registered ECC DDR3 1066/800 MHz SDRAM modules of up to 1 TB (per Intel's specs). It is strongly recommended that you do not mix memory modules of different speeds and sizes. Please follow all memory installation instructions given on Section 3-3 in Chapter 3.

Question: How do I update my BIOS?

It is recommended that you **do not** upgrade your BIOS if you are not experiencing any problems with your system. Updated BIOS files are located on our website at <http://www.supermicro.com>. Please check our BIOS warning message and the information on how to update your BIOS on our website. Select your motherboard model and download the BIOS file to your computer. Also, check the current BIOS

revision to make sure that it is newer than your BIOS before downloading. You can choose from the zip file and the .exe file. If you choose the zip BIOS file, please unzip the BIOS file onto a bootable USB device. Run the batch file using the format AMI.bat filename.rom from your bootable USB device to flash the BIOS. Then, your system will automatically reboot.

 **Warning:** Do not shut down or reset the system while updating the BIOS to prevent possible system boot failure!

 **Note:** The SPI BIOS chip used on this motherboard cannot be removed. Send your motherboard back to our RMA Department at Supermicro for repair. For BIOS Recovery instructions, please refer to the AMI BIOS Recovery Instructions posted at <http://www.supermicro.com>.

Question: What's on the CD that came with my motherboard?

Answer: The supplied compact disc has quite a few drivers and programs that will greatly enhance your system. We recommend that you review the CD and install the applications you need. Applications on the CD include chipset drivers for the Windows OS, security and audio drivers.

Question: How do I handle the used battery?

Answer: Please handle used batteries carefully. Do not damage the battery in any way; a damaged battery may release hazardous materials into the environment. Do not discard a used battery in the garbage or a public landfill. Please comply with the regulations set up by your local hazardous waste management agency to dispose of your used battery properly.

4-4 Returning Merchandise for Service

A receipt or copy of your invoice marked with the date of purchase is required before any warranty service will be rendered. You can obtain service by calling your vendor for a Returned Merchandise Authorization (RMA) number. When returning the motherboard to the manufacturer, the RMA number should be prominently displayed on the outside of the shipping carton, and the shipping package is mailed prepaid or hand-carried. Shipping and handling charges will be applied for all orders that must be mailed when service is complete. For faster service, You can also request a RMA authorization online (<http://www.supermicro.com>).

This warranty only covers normal consumer use and does not cover damages incurred in shipping or from failure due to the alternation, misuse, abuse or improper maintenance of products.

During the warranty period, contact your distributor first for any product problems.

Chapter 5

BIOS

5-1 Introduction

This chapter describes the AMI BIOS Setup Utility for the X8QB6-LF/X8QBE-LF. The AMI ROM BIOS is stored in a Flash EEPROM and can be easily updated. This chapter describes the basic navigation of the AMI BIOS Setup Utility setup screens.

Starting BIOS Setup Utility

To enter the AMI BIOS Setup Utility screens, press the <Delete> key while the system is booting up.



Note: In most cases, the <Delete> key is used to invoke the AMI BIOS setup screen. There are a few cases when other keys are used, such as <F1>, <F2>, etc.

Each main BIOS menu option is described in this manual. The Main BIOS setup menu screen has two main frames. The left frame displays all the options that can be configured. Grayed-out options cannot be configured. Options in blue can be configured by the user. The right frame displays the key legend. Above the key legend is an area reserved for text messages. When an option is selected in the left frame, it is highlighted in white. Often a text message will accompany it. (**Note:** AMI BIOS has default text messages built in. Supermicro retains the option to include, omit, or change any of these text messages.)

The AMI BIOS Setup Utility uses a key-based navigation system called "hot keys." Most of the AMI BIOS setup utility "hot keys" can be used at any time during the setup navigation process. These keys include <F1>, <F10>, <Enter>, <ESC>, arrow keys, etc.



Note: Options printed in **Bold** are default settings.

How To Change the Configuration Data

The configuration data that determines the system parameters may be changed by entering the AMI BIOS Setup utility. This Setup utility can be accessed by pressing at the appropriate time during system boot.

 **Note:** For BIOS Recovery, please refer to the UEFI BIOS Recovery Instructions posted on our website at <http://www.supermicro.com/support/manuals/>.

Starting the Setup Utility

Normally, the only visible Power-On Self-Test (POST) routine is the memory test. As the memory is being tested, press the <Delete> key to enter the main menu of the AMI BIOS Setup Utility. From the main menu, you can access the other setup screens. An AMI BIOS identification string is displayed at the left bottom corner of the screen below the copyright message.

 **Warning!** Do not upgrade the BIOS unless your system has a BIOS-related issue. Flashing the wrong BIOS can cause irreparable damage to the system. In no event shall Supermicro be liable for direct, indirect, special, incidental, or consequential damages arising from a BIOS update. If you have to update the BIOS, do not shut down or reset the system while the BIOS is updating to avoid possible boot failure.

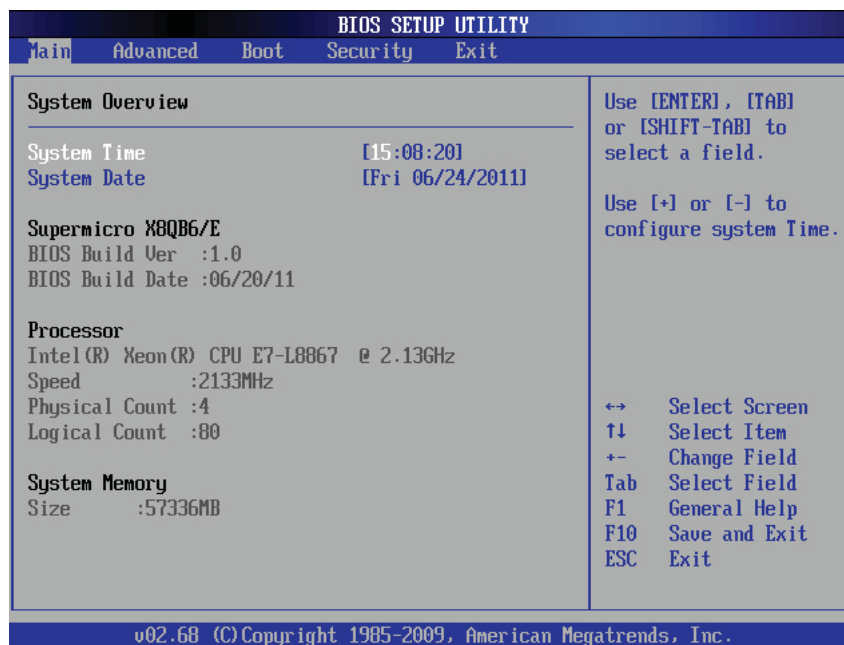

5-2 Main Setup

When you first enter the AMI BIOS Setup Utility, you will enter the Main setup screen. You can always return to the Main setup screen by selecting the Main tab on the top of the screen. The Main BIOS Setup screen is shown below.

System Overview: The following BIOS information will be displayed:

System Time/System Date

Use this option to change the system time and date. Highlight *System Time* or *System Date* using the arrow keys. Enter new values through the keyboard and press <Enter>. Press the <Tab> key to move between fields. The date must be entered in Day MM/DD/YY format. The time is entered in HH:MM:SS format. (**Note:** The time is in the 24-hour format. For example, 5:30 P.M. appears as 17:30:00.)

Supermicro X8QB6/E

- **BIOS Version:** This item displays the BIOS version used in your system.
- **BIOS Build Date:** This item displays the date when this BIOS was built.

Processor

The AMI BIOS will automatically display the status of the processor used in your system:

- **CPU Type:** This item displays the type of CPU used in the motherboard.
- **Speed:** This item displays the CPU speed as detected by the BIOS.
- **Physical Count:** This item displays the number of processors installed in your system as detected by BIOS.
- **Logical Count:** This item displays the number of CPU Cores detected in your system by BIOS.

System Memory

- **Size:** This displays the size of memory available in the system.

5-3 Advanced Setup Configurations

Use the arrow keys to select Advanced Settings and press <Enter> to access the submenu items.

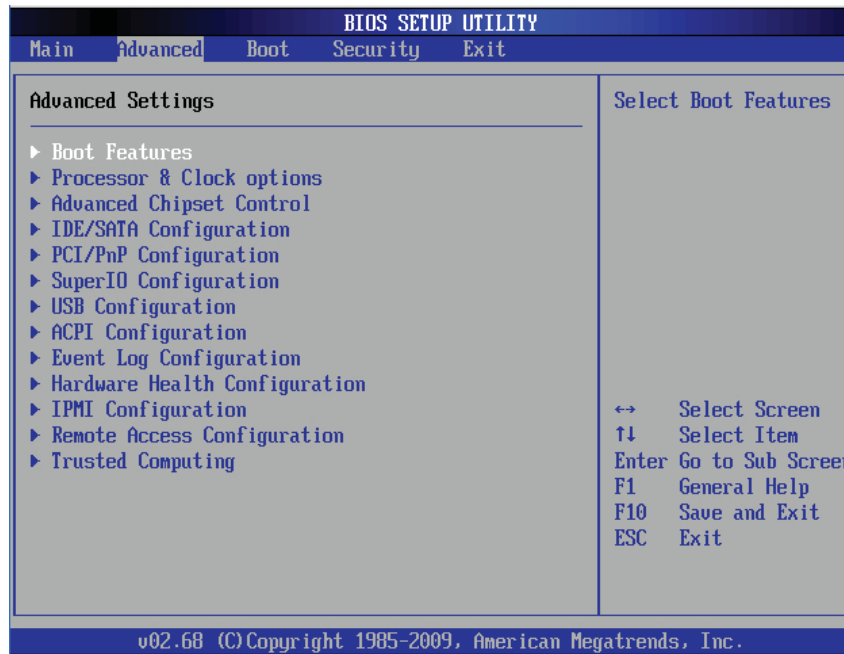

 **Warning:** Be sure to select the correct setting for each item in this section. A wrong setting selected may cause the system to malfunction.

► Boot Features

Quick Boot

If enabled, this feature will skip certain tests during POST to reduce the time needed for system boot. The options are **Enabled** and Disabled.

Quiet Boot

Use this feature to select the bootup screen display between POST messages or the OEM logo. Select Disabled to display the POST messages. Select Enabled to display the OEM logo instead of the normal POST messages. The options are **Enabled** and Disabled.

AddOn ROM Display Mode

This feature sets the display mode for the Option ROM. The options are **Force BIOS** and Keep Current.

Bootup Num-Lock

This feature is used to select the Power-on state for the Numlock key. The options are Off and **On**.

PS/2 Mouse Support

Select Enabled to enable PS/2 Mouse support. Select **Auto** to enable the onboard PS/2 mouse when a PS/2 mouse is detected. The options are Enable, Disabled, and **Auto**.

Wait For 'F1' If Error

This forces the system to wait until the 'F1' key is pressed when an error occurs. The options are Disabled and **Enabled**.

Hit 'Del' Message Display

Select Enabled to display "Press DEL to run Setup" during POST. The options are **Enabled** and Disabled.

Interrupt 19 Capture

Interrupt 19 is the software interrupt that handles boot disk functions. When this item is set to Enabled, the ROM BIOS of the host adaptors will "capture" Interrupt 19 at bootup and allow the drives that are attached to these host adaptors to function as bootable disks. If this item is set to Disabled, the ROM BIOS of the host adaptors will not capture Interrupt 19, and the drives attached to these adaptors will not function as bootable devices. The options are **Enabled** and Disabled.

Watch Dog Function

If enabled, the Watch Dog Timer will allow the system to reboot when it is inactive for more than 5 minutes. The options are Enabled and **Disabled**.

► Processor and Clock Options

This submenu displays the status of the processor used in the motherboard and allows the user to configure the Processor and Clock settings.

Clock Spread Spectrum

Select Enable to enable Clock Spectrum modulation support, which will allow BIOS to monitor and attempt to reduce the level of Electromagnetic Interference caused by the components whenever needed. The options are **Disabled** and Enabled.

Ratio CMOS Setting (Available when CPU Ratio is set to manual)

This option allows the user to set the ratio between the CPU Core Clock and the FSB Frequency. (**Note:** if an invalid ratio is entered, the AMI BIOS will restore the setting to the previous state.) The default setting depends on the type of CPU installed on the motherboard. The default setting for this motherboard is [16].

Hardware Prefetcher (Available when supported by the CPU)

If enabled, the hardware prefetcher will prefetch streams of data and instructions from the main memory to the L2 cache to improve CPU performance. The options are Disabled and **Enabled**.

Adjacent Cache Line Prefetch (Available when supported by the CPU)

If this feature is set to Disabled, the CPU prefetches the cache line for 64 bytes. If this feature is set to **Enabled**, the CPU prefetches both cache lines for 128 bytes as comprised. The options are Disabled and **Enabled**.

MPS and ACPI MADT Ordering

This feature allows the user to configure the MPS (Multi-Processor Specifications) and ACPI settings for your motherboard. Select Modern Ordering if XP or a newer version of Windows OS is used in the motherboard. Select Legacy Ordering if 2000 or an earlier version is used. The options are **Modern Ordering** and Legacy Ordering.

Max CPUID Value Limit

This feature allows the user to set the maximum CPU ID value. Enable this feature to boot the legacy operating systems that cannot support processors with extended CPUID functions. The options are Enabled and **Disabled** (for the Windows OS).

Intel® Virtualization Technology (Available when supported by the CPU)

Select Enabled to enable Virtualization Technology support which will allow one platform to run multiple operating systems and applications in independent partitions, creating multiple "virtual" systems in one physical computer. The options are **Enabled** and Disabled. **Note:** If there is any change to this setting, you will need to power off and restart the system for the change to take effect. Please refer to Intel's website for detailed information.

Execute-Disable Bit Capability (Available when supported by the OS and the CPU)

Select Enabled to enable the Execute Disable Bit support which will allow the processor to designate areas in the system memory where an application code can execute and where it cannot, thus preventing a worm or a virus from flooding illegal codes to overwhelm the processor or damaging the system during an attack. The default is **Enabled**. (Refer to Intel and Microsoft websites for more information.)

Intel AES-NI (Available when supported by the CPU)

Select **Enabled** to use Intel Advanced Encryption Standard (AES) Instructions to enhance system performance. The options are Disabled and **Enabled**.

Intel® HT (Hyper-Threading) Technology (Available when supported by the CPU)

Select Enabled to use Intel Hyper-Threading Technology which will allow the CPU to run multiple threads per CPU core and perform multiple tasks at the same time. The options are **Enabled** and Disabled.

CPU Multi-Core Enable/Disable (Available when supported by the CPU)

Select Enabled to enable the following CPU cores to enhance CPU performance. The options are Disabled and **Enabled**.

- Core 0 ~ Core 9

A20M

When the A20M# pin is enabled, it will force Address Bit #20 to zero (to be masked) to emulate the address wraparound for the real-address mode at 1 MB. Set this item to Enabled for the legacy operating systems and applications that require A20M support for the system to work properly. The options are Enabled and **Disabled**.

Intel® SpeedStep™ Technology

Intel EIST (Enhanced Intel SpeedStep Technology) allows the system to automatically adjust the processor voltage and core frequency in an effort to reduce power consumption and heat dissipation. Please refer to Intel's website for detailed information. The options are Disable (Disable GV3) and **Enable (Enable GV3)**.

Intel® TurboMode Tech (Available when Intel EIST Technology is enabled)

Select Enabled to use the TurboMode Technique to boost system performance. The options are **Enabled** and Disabled.

Intel® C-STATE Tech

If this feature is enabled, C-State is set by the system automatically to either C2, C3 or C4 state. The options are Disabled and **Enabled**. If this feature is set to Enabled, the following items will display.

C-State Package Limit Setting

If this feature is set to Auto, the AMI BIOS will automatically set the limit on the C-State package register. The options are **Auto**, C1, C3, C6 and C7.

C1 Auto Demotion

Select Enabled to allow the CPU to demote C3, C6, or C7 requests to C1 based on un-core auto-demote information. The options are Disabled and **Enabled**.

C3 Auto Demotion

If this feature is set to Enabled, the CPU will conditionally demote C6 or C7 requests to C3 based on un-core auto-demote information. The options are Disabled and **Enabled**.

ACPI T State

When this feature is enabled, CPU Throttling state will be reported in the ACPI (Advanced Configuration and Power Interface) protocol. The options are **Enabled** and Disabled.

► Advanced Chipset Control

The items included in the Advanced Settings submenu are listed below.

► CPU Bridge Configuration

► QPI Configuration

QuickPath Interconnect (QPI) is the connection between the CPU and the motherboard's I/O hub. This section displays the following QPI items.

MMConfigBase

This item is used to select the space-based address for memory_mapped configuration. The options are **0x8000 0000**, 0x4000 0000, and 0xC000 0000.

MMIOH Size Per IOH

Use this feature to select the memory_mapped IOH size to be allocated to each IOH. The options are **2G**, 4G, 6G, and 8G.

Logical Interrupt Mode

This item is used to select the logical interrupt mode. The options are **Flat Mode** and Cluster Mode.

Cluster Mode Check Sampling

Select Enabled to check if the APICID in an IntPriUpd message is not zero. The options are **Enabled** and Disabled.

QPI Debug Message Output Level

This feature allows the user to decide the level of an QPI debug message to be sent to the user. The options are **Err/Warn/Info0/1**, Err/Warn/Info0, and Err/Warn.

CRC Mode

Use this feature to select the QPI CRC (Cyclic Redundancy Check) mode, which will determine how often the raw computer data stored in a network or a hard disk device is checked for CRC. The options are **8Bit CRC** and 16Bit Rolling CRC.

QPI (Quick Path Interconnect) Links Speed

Use this feature to set the data transfer speed for QPI Link connections. The options are Slow and **Fast**.

QPI Frequency Select (Available if the item - QPI Link Speed is set to Fast)

This feature is used to set the desired QPI frequency. The options are 4.800 GT, 5.866GT, 6.400 GT and **Auto**.

QPI Scrambling

Select Enabled to enable Bit-Shuffling support which will allow bits in the data flow to be shifted around for CRC checking during data transmission and receiving between the CPUs or between a CPU and an IO hub (IOH). The options are **Enabled** and Disabled.

Tracker Mode 7

Select Enabled to use the graphics mode-Tracker Mode 7 to achieve 3D effect for the Westmere-EX platform. The options are **Enabled** and Disabled.

► Integrated Memory Controller Configuration**Interleave Type**

Use this feature to select memory interleaving mode. Select Intra-Socket Interleaving to enable memory interleaving between the blocks of memory modules installed in the same DIMM slot. Select Inter-Socket to enable memory interleaving between the blocks of memory modules installed in different DIMM slots. Select 2 Way Interleaving to support dual-channel Interleaving. Select 4 Way Interleaving to support 4-way memory interleaving. Select 8 Way Interleaving to support 8-way memory interleaving. The options are No Interleaving, **2 Way Interleaving, Intra Socket**; 4 Way Interleaving, Intra Socket; and 8 Way Interleaving, Inter Socket.

Interleave Order

Use this feature to set the order of memory interleaving. The options are High Only, High Low, **Low High 0**, and Low High 1.

Mirroring

Mirroring support allows data stored in one location to be copied into another location for data redundancy and security. The options are listed below:

- **No Mirroring** (Mirroring Disabled),
- Intra-Socket Mirrored Nx1 to Nx3 (Memory Controller 1 to Memory Controller 3 of the same DIMM socket),
- Intra-Socket Mirrored Nx3 to Nx1 (Memory Controller 3 to Memory Controller 1 of the same DIMM socket),
- Inter-Socket Mirrored S0 (Socket 0) to S1 (Socket 1), and S2 (Socket 2) to S3 (Socket 3),
- Inter-Socket Mirrored S0 (Socket 0) to S2 (Socket 2) and S1 (Socket 1) to S3 (Socket 3),
- Inter-Socket Mirrored S0 (Socket 0) to S3 (Socket 3) and S1 (Socket 1) to S2 (Socket 2).

Spare Enable

Select Enabled to enable spare support for all sockets, creating a spare drive for each socket. The options are Enabled and **Disabled**.

Mapper Mode

Use this feature to set the memory_mapper mode, which is used to translate local physical addresses presented by a media device into DRAM memory addresses (in terms of rank, bank, row and column). Select Open to maximize open_page hits. Select Close to minimize rank conflicts and to maximize simultaneous read/write bandwidth to boost performance. Select Adaptive to spread power dissipation over different DIMM modules to avoid memory overheat. The options are **Close**, Open and Adaptive.

Frequency Limit

This feature forces a DDR3 memory module to run at a frequency other than what the system has detected. The available options are **Auto**, 800 MHz, 978 MHz, 1067 MHz, and **Auto**.

Initialization Mode

Use this feature to select the memory initialization mode. The options are Serial and **Parallel**.

Hemisphere Mode

This feature is used to set the memory hemisphere mode. Select Enabled to prevent CPU's cache agent 1 from accessing cache agent 2 in an effort to reduce memory latency and maximize performance. This setting requires that both DIMM modules and DRAM sizes are configured in the same way. Select Disabled to allow a CPU's cache agent 1 to access cache agent 2. The options are Disabled and **Enabled**.

Page Policy

Use this feature to configure Page Policy settings, which determine how memory blocks are cached in a DRAM buffer and a memory module accesses memory resources. Select Open to optimize memory performance. Select Close to use memory safe mode. Select Adaptive to balance safety and performance. The options are Close, **Open** and Adaptive.

Scheduler Policy

Use this feature to configure Scheduler_Policy settings. The scheduler is used to translate memory read/write commands into memory sub-commands for easy execution. Select Static Trade_Off to balance read/write priority. Select Static Read_Priority to optimize read latency and bandwidth. Select Static Write_Priority to optimize write bandwidth to expedite command writing and command execution. Select Adaptive to minimize latency. The options are Static Trade_Off, Static Read_Priority, Static Write_Priority, and **Adaptive**.

ECC Check Time Interval

This feature is used to set the time interval between each ECC Memory checking. If an ECC error occurs, an error message will also be sent via IPMI. The options are 100 Msec, 1 Sec, 10 Sec, 1 Min, **5 Minutes**, and 10 Minutes.

►North Bridge Configuration

This feature allows the user to configure North Bridge settings.

Relaxed Ordering

Select Enabled to enable PCI-Express Relaxed_Ordering support which will allow certain transactions to be executed first by passing other transactions that were issued earlier, violating the strict PCI-E ordering rules. The options are **Auto**, Disabled and Enabled.

Maximum Payload Size

This feature is used to set the maximum payload size for a PCI-Express device. Please refer to your add-on card user guide for the desired setting. The options are **Auto**, 128 Bytes, 256 Bytes, 512 Bytes, 1024 Bytes, 2048 Bytes, 4096 Bytes,

and Maximum supported.

Extended Tag Field

Select Enabled to use the 8-bit Tag field of a device as a requester. The options are **Auto**, Disabled and Enabled.

No Snoop

If this feature is set to Enabled, No_Snoop option for a PCI-Express device will be enabled. The options are **Auto**, Disabled and Enabled.

Maximum Read Request Size

This feature is used to set the maximum read request size for a PCI-Express device. The options are **Auto**, 128 Bytes, 256 Bytes, 512 Bytes, 1024 Bytes, 2048 Bytes, 4096 Bytes, and Maximum supported.

Active State Power Management

Select Enabled to use the power management for signal transactions between the PCI Express L0 and L1 Links. Select Enabled to configure PCI-Exp. L0 and L1 Link power states. The options are **Disabled** and Enabled.

Extended Synch

Select Enabled to generate extended synchronization patterns. The options are **Auto**, Disabled and Enabled.

Intel VT-d

Select Enabled to enable Intel Virtualization Technology support for Direct I/O VT-d by reporting the I/O device assignments to VMM through the DMAR ACPI Tables. This feature offers fully-protected I/O resource-sharing across the Intel platforms, providing the user with greater reliability, security and availability in networking and data-sharing. The settings are Enabled and **Disabled**.

Thermal Sensor

Select Enabled to activate the thermal sensor. The options are **Disabled** and Enabled.

► South Bridge Configuration

This feature allows the user to configure Intel ICH South Bridge settings.

USB Functions

This feature allows the user to decide the number of onboard USB ports to be enabled. The Options are: Disabled, 2 USB Ports, 4 USB Ports, 6 USB Ports, 8 USB

Ports, 10 USB Ports, and **12 USB Ports**. (If this item is set to Enabled, USB 2.0 Controller will be enabled.)

USB Port Configuration

This feature is used to configure USB port settings. The Options are: **6x6 USB Ports** and 8x4 USB Ports.

USB 2.0 Controller

Select Enabled to activate the USB 2.0 Controller. The options are **Enabled** and Disabled. (**Note:** If the item - USB Functions is enabled, USB 2.0 Controller will always be enabled. When the item - USB Functions is set to Disabled, the user has the option to enable or disable USB 2.0 Controller.)

GPI09 Configuration

This feature is used to configure the GPI09 computer electronics meter settings. The Options are: **WOL (Wake-On-LAN) Enabled**, High, and Low.

HDA Controller

Select Enabled to enable the High-Definition Audio Controller. The settings are **Enabled** and Disabled.

SMBUS Controller

Select Enabled to enable the System_Management Bus Controller. The settings are **Enabled** and Disabled.

SLP_S4# Min. Assertion Width

This feature allows the user to set the minimum SLP_S4# Assertion Width to make sure that DRAMs have safe power cycles. The settings are **4 to 5 seconds**, 3 to 4 Seconds, 2 to 3 Seconds, and 1 to 2 Seconds.

Restore on AC Power Loss

Use this feature to set the power state after a power outage. Select Power-Off for the system power to remain off after a power outage. Select Power-On for the system power to be turned on after a power outage. Select Last State to allow the system to resume its last state before the power outage. The options are Power-On, Power-Off and **Last State**.

SATA Master Break Event

If this feature is set to Enabled, activities on the SATA master drive will break from the C3/C6 state. The settings are Enabled and **Disabled**.

PCIE Ports Configuration

PCIE Port 0 ~ PCIE Port 4

This feature is used to configure PCI-E port settings. Select Auto to allow a specified PCIE port to be enabled if a PCIE device is detected. The settings are **Auto**, **Enabled** and **Disabled**.

PCIE High Priority Port

This feature allows the user to select the PCIE High Priority port. The settings are **Disabled**, **Port 0**, **Port 1**, **Port 2**, **Port 3**, **Port 4**, and **Port 5**.

PCIE Port 0 IOxAPIC Enable ~ PCIE Port 5 IOxAPIC Enable

Select **Enable** to enable IOxAPIC support for a PCIE port specified. The settings are **Enabled** and **Disabled**.

►IDE/SATA Configuration

When this submenu is selected, the AMI BIOS will automatically detect the presence of the IDE/SATA devices, and displays the following items.

SATA#1 Configuration

If **Compatible** is selected, it sets SATA#1 to the legacy_compatible mode. Selecting **Enhanced** sets SATA#1 to the native SATA mode. The options are **Disabled**, **Compatible** and **Enhanced**.

Configure SATA#1 as (Not available when SATA#1 Configuration is disabled)

Use this feature to select the drive type for SATA#1. The options are **IDE**, **RAID** and **AHCI**. (When the option-RAID is selected, the item-ICH RAID Code Base will appear. When the option-AHCI is selected, the item-ICH AHCI Codebase will be available.)

ICH RAID Code Base (Available when the option-RAID is selected.)

Select **Intel** to use Intel's SATA RAID firmware to configure Intel's SATA RAID settings. Select **Adaptec** to use Adaptec's SATA RAID firmware to configure Adaptec's SATA RAID settings. The options are **Intel** and **Adaptec**.

ICH AHCI Codebase (Available when the option-AHCI is selected.)

Use this feature to select the AHCI Codebase for the ICH South Bridge. The options are **BIOS Native Module** and **Intel AHCI ROM**.

SATA#2 Configuration (Available when the option-IDE is selected.)

Select Enhanced to set SATA#2 to Native SATA mode. The options are Disabled and **Enhanced**.

Primary IDE Master/Slave, Secondary IDE Master/Slave, Third IDE Master, and Fourth IDE Master

These settings allow the user to set the parameters for the slots indicated above. Press <Enter> to activate the following submenu items. Set the correct configurations accordingly. The items included in the submenu are listed below.

Type

Use this item to select the type of device connected to the system. The options are Not Installed, **Auto**, CD/DVD and ARMD.

LBA/Large Mode

LBA (Logical Block Addressing) is a method of addressing data on a disk drive. In the LBA mode, the maximum drive capacity is 137 GB. For drive capacities over 137 GB, your system must support a 48-bit LBA mode. If not, contact your manufacturer or install an ATA/133 IDE controller card that supports 48-bit LBA mode. The options are Disabled and **Auto**.

Block (Multi-Sector Transfer)

Block Mode boosts the IDE drive performance by increasing the amount of data transferred. Only 512 bytes of data can be transferred per interrupt if Block Mode is not used. Block Mode supports transfers of up to 64 KB per interrupt. Select Disabled to allow data to be transferred from and to a device one sector at a time. Select Auto to allow data transfer from and to a device multiple sectors at a time if the device supports it. The options are **Auto** and Disabled.

PIO Mode

The IDE PIO (Programmable I/O) Mode programs timing cycles between the IDE drive and the programmable IDE controller. As the PIO mode increases, the cycle time decreases. The options are **Auto**, 0, 1, 2, 3, and 4.

Select Auto to allow AMI BIOS to automatically detect the PIO mode. Use this value if the IDE disk drive support cannot be determined.

Select 0 to allow AMI BIOS to use PIO mode 0. It has a data transfer rate of 3.3 MB/s.

Select 1 to allow AMI BIOS to use PIO mode 1. It has a data transfer rate of 5.2 MB/s.

Select 2 to allow AMI BIOS to use PIO mode 2. It has a data transfer rate of 8.3 MB/s.

Select 3 to allow AMI BIOS to use PIO mode 3. It has a data transfer rate of 11.1 MB/s.

Select 4 to allow AMI BIOS to use PIO mode 4. It has a data transfer bandwidth of 32-Bits. Select Enabled to enable 32-Bit data transfer.

Select UDMA5 to allow BIOS to use Ultra DMA mode 5. It has a data transfer rate of 133 MB/s.

Select UDMA6 to allow BIOS to use Ultra DMA mode 6. It has a data transfer rate of 133 MB/s. The options are **Auto**, SWDMA_n, MWDMA_n, and UDMA_n.

DMA Mode

Select Auto to allow BIOS to automatically detect IDE DMA mode when IDE disk drive support cannot be determined.

Select SWDMA0 to allow BIOS to use Single Word DMA mode 0. It has a data transfer rate of 2.1 MB/s.

Select SWDMA1 to allow BIOS to use Single Word DMA mode 1. It has a data transfer rate of 4.2 MB/s.

Select SWDMA2 to allow BIOS to use Single Word DMA mode 2. It has a data transfer rate of 8.3 MB/s.

Select MWDMA0 to allow BIOS to use Multi-Word DMA mode 0. It has a data transfer rate of 4.2 MB/s.

Select MWDMA1 to allow BIOS to use Multi-Word DMA mode 1. It has a data transfer rate of 13.3 MB/s.

Select MWDMA2 to allow BIOS to use Multi-Word DMA mode 2. It has a data transfer rate of 16.6 MB/s.

Select UDMA0 to allow BIOS to use Ultra DMA mode 0. It has a data transfer rate of 16.6 MB/s. It has the same transfer rate as PIO mode 4 and Multi-Word DMA mode 2.

Select UDMA1 to allow BIOS to use Ultra DMA mode 1. It has a data transfer rate of 25 MB/s.

Select UDMA2 to allow BIOS to use Ultra DMA mode 2. It has a data transfer rate of 33.3 MB/s.

Select UDMA3 to allow BIOS to use Ultra DMA mode 3. It has a data transfer rate of 44.4 MB/s.

Select UDMA4 to allow BIOS to use Ultra DMA mode 4. It has a data transfer rate of 66.6 MB/s.

Select UDMA5 to allow BIOS to use Ultra DMA mode 5. It has a data transfer rate of 100 MB/s.

Select UDMA6 to allow BIOS to use Ultra DMA mode 6. It has a data transfer rate of 133 MB/s. The options are **Auto**, SWDMA_n, MWDMA_n, and UDMA_n.

S.M.A.R.T. For Hard disk drives

Self-Monitoring Analysis and Reporting Technology (SMART) can help predict impending hard disk drive failures. Select Auto to allow AMI BIOS to automatically detect hard disk drive support. Select Disabled to prevent AMI BIOS from using the S.M.A.R.T. Select Enabled to allow AMI BIOS to use the S.M.A.R.T. to support hard drive disk. The options are Disabled, Enabled and **Auto**.

32Bit Data Transfer

Select Enabled to support 32-bit IDE data transfer. The options are **Enabled** and Disabled.

Hard Disk Write Protect

Select Enabled to support Hard Disk Write Protect to prevent data from being written to a hard drive. The options are Enabled or **Disabled**.

IDE Detect Timeout (sec)

Use this feature to set the timeout value to allow BIOS to detect the ATA, ATAPI devices installed in the system. The options are 0 (sec), 5, 10, 15, 20, 25, 30, and **35**.

►PCI/PnP Configuration

Clear NVRAM

Select Yes to clear Non-Volatile Random Access (Flash) Memory (NVRAM) during system boot. The options are **No** and Yes.

Plug & Play OS

Select Yes to allow the OS to configure Plug & Play devices. (This is not required for system boot if your system has an OS that supports Plug & Play.) Select **No** to allow AMI BIOS to configure all devices in the system.

PCI Latency Timer

This feature sets the PCI Latency Timer for each PCI device installed on a PCI bus. Select 64 to set the PCI Latency Timer to 64 PCI clock cycles. The options are 32, **64**, 96, 128, 160, 192, 224 and 248.

Palette Snooping

Select Enabled to allow BIOS to inform PCI-E devices that an ISA graphics device is installed in the system so that the ISA graphics card can function properly. The options are **Disabled** and Enabled.

SR-IOV Supported

Single Root I/O Virtualization is an industry-standard mechanism that allows devices to be shared simultaneously among several virtual machines. SR-IOV is capable of partitioning a PCI device into several virtual interfaces in order to share the resources of a PCI Express (PCIe) device under a virtual environment. The options are **Disabled** and Enabled.

Onboard VGA Device

Select Enabled to use VGA devices. The options are Disabled and **Enabled**.

Boot Graphic Adapter Priority

This feature selects the graphics adapter to be used as the primary boot device. The options are **Auto** and Onboard VGA Device.

Onboard SAS OPROM

Select Enabled to enable Onboard SAS Option ROM which will allow you to boot the computer using a SAS device. The options are **Enabled** and Disabled.

Onboard LAN Option ROM Select

Select iSCSI to use iSCSI Option ROMs to boot the computer. Select PXE to use PXE Option ROMs to boot the computer. The options are iSCSI and **PXE**.

LAN1 Option ROM

Select Enabled to enable the onboard LAN1 Option ROM to boot the computer using a network interface. The options are **Enabled** and Disabled.

LAN2 Option ROM

Select Enabled to enable the onboard LAN2 Option ROM to boot the computer using a network interface. The options are Enabled and **Disabled**.

► Super IO Device Configuration

Serial Port1 Address, Serial Port2 Address

This option specifies the base I/O port address and the Interrupt Request address for Serial Port 1 and Serial Port 2. Select Disabled to prevent the serial port from accessing any system resources. When this option is set to Disabled, the serial port physically becomes unavailable. Select 3F8/IRQ4 to allow the serial port to use 3F8 as its I/O port address and IRQ 4 for the interrupt address. The options for Serial Port1 are Disabled, **3F8/IRQ4**, 3E8/IRQ4, 2E8/IRQ3 and 2F8/IRQ3. The options for Serial Port2 are Disabled, **2F8/IRQ3**, 3E8/IRQ4, 3F8/IRQ4, and 2E8/IRQ3.

Serial Port2 Select

Select SOL for Serial Port 2 to be used for SOL (Serial-Over-LAN). Select COM to use Serial Port 2 for onboard COM2 connection. The options are **SOL** and **COM**.

►USB Configuration

This feature allows the user to configure USB settings for the motherboard.

Legacy USB Support

Select Enabled to use Legacy USB devices. If this item is set to Auto, Legacy USB support will be automatically enabled if a legacy USB device is installed on the motherboard, and vice versa. The settings are Disabled, **Enabled** and Auto.

Port60h/64h Emulation

Select Enabled to enable 60h/64h emulation so that a USB keyboard can be supported by an operating system that is not compatible with USB devices. The options are Enabled and **Disabled**.

USB 2.0 Controller Mode

This setting allows you to select USB 2.0 Controller mode. The options are **Hi-Speed (480 Mbps)** and Full Speed (12 Mbps).

BIOS EHCI Hand-Off

Select Enabled to support BIOS Enhanced Host Controller Interface to provide a workaround solution for an operating system that does not support EHCI Hand-Off technology. When this item is enabled, the EHCI Interface will be changed from the BIOS-controlled to the OS-controlled. The options are Disabled and **Enabled**.

Legacy USB1.1 HC Support

Select Enabled to enable Legacy USB 1.1 HC support. The settings are Disabled and **Enabled**.

Hot-Plug USB FDD Support

When this item is set to Enabled, a dummy Floppy Device Drive will be created as a Hot-Plug Floppy device in the system. When this item is set to **Auto**, a dummy floppy device will not be created if no USB FDD device is detected. The options are Disabled, Enabled, and **Auto**.

►ACPI Configuration

Use this feature to configure Advanced Configuration and Power Interface (ACPI) power management settings for your system.

► Advanced ACPI Configuration

This feature allows the user to configure Advanced ACPI (Advanced Configuration and Power Interface) settings.

ACPI Version Features

Use this feature to select the ACPI version to be used in the system. The options are ACPI v1.0, **ACPI v2.0** and ACPI v3.0. Please refer to ACPI's website for further explanation: <http://www.acpi.info/>.

ACPI APIC Support

Select Enabled to include the ACPI APIC Table Pointer in the RSDT (Root System Description Table) pointer list. The options are **Enabled** and Disabled.

AMI OEMB Table

Select Enabled to include the OEMB Table Pointer in the RSDT (Root System Description Table) pointer list. The options are **Enabled** and Disabled.

Headless Mode (Available ACPI Aware O/S='Yes')

This feature is used to enable system to function without a keyboard, monitor or mouse attached. The options are Enabled and **Disabled**.

NUMA Support

Select Enabled to enable Non-Uniform Memory Access support to improve CPU performance for a system that has an OS with NUMA support. The options are **Enabled** and Disabled.

► Chipset ACPI Configuration

This feature is used to configure Chipset ACPI (Advanced Configuration and Power Interface) settings.

Energy Lake Feature

Select Enabled to use Intel Energy Lake technology to enhance power efficiency. The options are **Disabled** and Enabled.

APIC ACPI SCI IRQ

When this item is set to Enabled, APIC ACPI SCI IRQ is supported by the system. The options are Enabled and **Disabled**.

USB Device Wakeup From S3/S4

Select Enable to wake up the system via a USB device when the system is in S3 or S4 State. The options are Enabled and **Disabled**.

High Precise Event Timer

Select Enabled to activate the High Precise Event Timer (HPET) to produce periodic interrupts at a much higher frequency than a Real-time Clock (RTC) does in synchronizing multimedia streams, providing smooth playback and reducing the dependency on other timestamp calculation devices, such as an x86 RDTSC Instruction embedded in the CPU. The High Performance Event Timer is used to replace the 8254 Programmable Interval Timer. The options are Enabled and **Disabled**.

► General WHEA Configuration

WHEA Support

Select Enabled to support the Windows Hardware Error Architecture (WHEA) platform and provide a common infrastructure for the system to handle hardware errors within the Windows OS environment to reduce system crashes and to enhance system recovery and health monitoring. The options are **Enabled** and Disabled.

► Event Log Configuration

View Event Log

Use this option to view the System Event Log.

Mark All Events as Read

This option marks all events as read. The options are **OK** and Cancel.

Clear Event Log

This option clears the Event Log memory of all messages. The options are **OK** and **Cancel**.

► Hardware Health Event Monitoring

This feature is used to monitor system health and review the status of each item as displayed.

CPU Overheat Alarm

This option allows the user to select the CPU Overheat Alarm setting which determines when the CPU OH alarm will be activated to provide warning of possible CPU overheat.



Warning! 1. Any temperature that exceeds the CPU threshold temperature predefined by the CPU manufacturer may result in CPU overheat or system instability. When the CPU temperature reaches this predefined threshold, the CPU and system cooling fans will run at full speed. 2. To

avoid possible system overheating, please be sure to provide adequate airflow to your system.

The options are:

- The Early Alarm: Select this setting if you want the CPU overheat alarm (including the LED and the buzzer) to be triggered as soon as the CPU temperature reaches the CPU overheat threshold as predefined by the CPU manufacturer.
- **The Default Alarm:** Select this setting if you want the CPU overheat alarm (including the LED and the buzzer) to be triggered when the CPU temperature reaches about 5°C above the threshold temperature as predefined by the CPU manufacturer to give the CPU and system fans additional time needed for CPU and system cooling. In both the alarms above, please take immediate action as shown below.

CPU 1 Temperature ~ CPU 4 Temperature/System Temperature 1 Reading~ System Temperature 4 Reading

This feature displays current temperature readings for the CPU and the System as specified above.

The following items will be displayed for your reference only:

CPU 1 Temperature ~ CPU 4 Temperature

The CPU thermal technology that reports absolute temperatures (Celsius/Fahrenheit) has been upgraded to a more advanced feature by Intel in its newer processors. The basic concept is each CPU is embedded by unique temperature information that the motherboard can read. This 'Temperature Threshold' or 'Temperature Tolerance' has been assigned at the factory and is the baseline on which the motherboard takes action during different CPU temperature conditions (i.e., by increasing CPU Fan speed, triggering the Overheat Alarm, etc). Since CPUs can have different 'Temperature Tolerances', the installed CPU can now send information to the motherboard what its 'Temperature Tolerance' is, and not the other way around. This results in better CPU thermal management.

Supermicro has leveraged this feature by assigning a temperature status to certain thermal conditions in the processor (Low, Medium and High). This makes it easier for the user to understand the CPU's temperature status, rather than by just simply seeing a temperature reading (i.e., 25°C). The CPU Temperature feature will display the CPU temperature status as detected by the BIOS:

Low – This level is considered as the 'normal' operating state. The CPU temperature is well below the CPU 'Temperature Tolerance'. The motherboard fans and CPU will run normally as configured in the BIOS (Fan Speed Control).

User intervention: No action required.

Medium – The processor is running warmer. This is a ‘precautionary’ level and generally means that there may be factors contributing to this condition, but the CPU is still within its normal operating state and below the CPU ‘Temperature Tolerance’. The motherboard fans and CPU will run normally as configured in the BIOS. The fans may adjust to a faster speed depending on the Fan Speed Control settings.

User intervention: No action is required. However, consider checking the CPU fans and the chassis ventilation for blockage.

High – The processor is running hot. This is a ‘caution’ level since the CPU’s ‘Temperature Tolerance’ has been reached (or has been exceeded) and may activate an overheat alarm.

User intervention: If the system buzzer and Overheat LED has activated, take action immediately by checking the system fans, chassis ventilation and room temperature to correct any problems.



Notes: 1. The system may shut down if it continues for a long period to prevent damage to the CPU.

2. The information provided above is for your reference only. For more information on thermal management, please refer to Intel’s _ at www.Intel.com.

System Temperature 1 Reading ~ System Temperature 4 Reading

The system temperature as specified above will be displayed (in degrees in Celsius and Fahrenheit) as it is detected by the BIOS.

Fan 1 Speed ~ Fan 11 Speed

This feature displays the fan speed readings from fan interfaces Fan 1 through Fan 10.

Fan Speed Control Modes

This feature allows the user to decide how the system controls the speeds of the onboard fans. The CPU temperature and the fan speed are correlative. When the CPU on-die temperature increases, the fan speed will also increase for effective system cooling. Select "Full Speed/FS" to allow the onboard fans to run at full speed for maximum cooling. The FS setting is recommended for special system configuration or debugging. Select "Performance/PF" for better system cooling. The PF setting is recommended for high-power-consuming and high-density systems. Select "Balanced/BL" for the onboard fans to run at a speed that will balance the needs between system cooling and power saving. The BL setting is recommended for regular systems with normal hardware configurations. Select "Energy Saving/ES" for best power efficiency and maximum quietness. The Options are: Full Speed/FS, Performance/PF, **Balanced/BL**, and Energy Saving/ES.

Voltage Monitoring

CPU1 Vcore, CPU2 Vcore, CPU3 Vcore, CPU4 Vcore, +1.0V, +1.2V, +1.8V, +1.1VSB, +12V, VDIMM, 3.3V V, 3.3VSB, Battery Voltage, and IOPV12.

► IPMI Configuration

Intelligent Platform Management Interface (IPMI) is a set of common interfaces that IT administrators uses to monitor system health and to manage the system as a whole. For more information on the IPMI specifications, please visit Intel's website at www.intel.com.

Status of BMC

The Baseboard Management Controller (BMC) manages the interface between system management software and platform hardware. This item displays the status of the current BMC controller.

IPMI Firmware Version

This item displays the current IPMI Firmware Version.

► View BMC System Event Log

This feature displays the BMC System Event Log (SEL). It shows the total number of entries of BMC System Events. To view an event, select an Entry Number and press <Enter> to display the information as shown in the screen.

- Total Number of Entries
- SEL Record ID
- SEL Record Type
- Event Timestamp
- Generator ID
- Event Message Format Ver.
- Event Sensor Type
- Event Sensor Number
- Event Dir Type
- Event Data.

Clear BMC System Event Log

Clear BMC System Log now

Select OK and press <Enter> to clear the BMC system log immediately. Select Cancel to keep the BMC System log. The options are **OK** and Cancel.

 **Caution:** Any cleared information is unrecoverable. Make absolutely sure that you will no longer need any data stored in the log before clearing the BMC Event Log.

► Set LAN Configuration

This feature allows the user to configure the IPMI LAN adapter with a network address as shown in the following graphics.

Channel Number - This feature displays the channel number.

Channel Number Status - This feature returns the channel status for the Channel Number selected above: "Channel Number is OK" or "Wrong Channel Number".

► IP Address

Parameter Selector

This item displays the status of the IP Address Parameter Selector.

IP Address Source

This feature allows the user to select how an IP address is assigned to a client computer or network device. Select DHCP (Dynamic Host Configuration Protocol) to allow a client (computer or device) to obtain an IP address from a DHCP server that manages a pool of IP addresses and network information on a "request and grant" basis. Upon timeout (or lease expiration), the IP address assigned to the client can be reassigned to a new client. Select Static (Static Allocation) to allow the host server to allocate an IP address based on a table containing MAC Address/IP Address pairs that are manually entered (probably by a network administrator). Only clients with a MAC address listed in the MAC/IP Address Table will be assigned an IP address. The IP Address allocated to the client is on a longer term basis than that assigned by the DHCP mentioned in the other option. The options are **DHCP** and Static.

IP Address

The BIOS will automatically enter the IP address for this machine; however it may be overwritten. The value of each three-digit number separated by dots should not exceed 255.

Current IP Address in BMC

The BIOS will automatically enter the current IP address in BMC for this machine; however it may be overwritten. The value of each three-digit number separated by dots should not exceed 255.

►MAC Address Configuration

Parameter Selector

This item displays the status of the MAC Address Parameter Selector.

Current Mac Address in BMC

The BIOS will automatically enter the current Mac address in BMC for this machine; however it may be overwritten. Mac addresses are 6 two-digit hexadecimal numbers (Base 16, 0 ~ 9, A, B, C, D, E, F) separated by dots. (i.e., 00.30.48.D0.D4.60).

►Subnet Mask Configuration

Parameter Selector

This item displays the status of the Parameter Selector.

Subnet Mask

This item displays the current subnet mask setting for your IPMI connection. The value of each three-digit number separated by dots should not exceed 255.

Current Subnet Mask in BMC

The BIOS will automatically enter the current subnet mask in BMC for this machine; however it may be overwritten. The value of each three-digit number separated by dots should not exceed 255.

►Gateway Address

Parameter Selector

This item displays the status of the Gateway Address Parameter Selector.

Gateway Address

The BIOS will automatically enter the Gateway address of this machine; however it may be overwritten. The value of each three-digit number separated by dots should not exceed 255.

Current IP Address in BMC

The BIOS will automatically enter the current IP address in BMC for this machine; however it may be overwritten. The value of each three-digit number separated by dots should not exceed 255.

► Remote Access Configuration

Remote Access

This allows the user to enable the Remote Access support. The options are Disabled and **Enabled**. If Remote Access is set to Enabled, the following items will display:

Serial Port Number

This feature allows the user to decide which serial port to use for Console Redirection. The options are COM 1 and **COM 2**.

Base Address, IRQ

This item displays the based address and IRQ of the serial port specified.

Serial Port Mode

Use this item to set the serial port mode for Console Redirection. The options are **115200 8, n 1**; 57600 8, n, 1; 38400 8, n, 1; 19200 8, n, 1; and 9600 8, n, 1.

Flow Control

This feature allows the user to set the flow control for Console Redirection. The options are **None**, Hardware, and Software.

Redirection After BIOS POST

Select Disabled to turn off Console Redirection after Power-On Self-Test (POST). Select Always to keep Console Redirection active all the time after POST. (**Note:** This setting may not be supported by some operating systems.) Select Boot Loader to keep Console Redirection active during POST and Boot Loader. The options are Disabled, Boot Loader, and **Always**.

Terminal Type

This feature allows the user to select the target terminal type for Console Redirection. The options are **ANSI**, VT100, and VT-UTF8.

VT-UTF8 Combo Key Support

A terminal keyboard definition that provides a way to send commands from a remote console. The options are **Enabled** and Disabled.

Sredir Memory Display Delay

This feature defines the length of time in seconds to display memory information. The options are **No Delay**, Delay 1 Sec, Delay 2 Sec, and Delay 4 Sec.

► Trusted Computing (Optional)

TCG/TPM Support

Select Yes on this item and enable the TPM jumper on the motherboard to enable TCG (TPM 1.1/1.2)/TPM support to improve data integrity and network security. The options are **No** and Yes. If this feature is set to Yes, the following items will display.

Indicate Physical (Available when TCG/TPM Support = 'Yes')

Select Yes for BIOS to detect the presence of TPM devices at system boot. Select No to hide the presence of TPM devices at system boot. The options are Yes and **No**.

TPM Deactivated (Available when TCG/TPM Support = 'Yes')

Select Set to disable TPM support at bootup. Select Clear to activate the TPM devices to at bootup. Select Don't Change to keep the current TPM support status. The options are Set, Clear, and **Don't Change**.

TPM Owner (Available when TCG/TPM Support = 'Yes')

This feature allows the user to configure TPM Owner settings. The options are **Don't Change**, Enable Install, Disable Install, and Clear.

Execute TPM Command (Available when TCG/TPM Support = 'Yes')

Select Enabled to execute TPM commands you've selected. Select Don't Change to keep the current TPM commands without making any changes. Select Disabled to abandon the changes you have made on TPM commands. The options are Enabled, Disabled and **Don't Change**.

TPM Enable/Disable Status

This item displays the status of TPM Support to indicate if TPM is currently enabled or disabled.

TPM Owner Status

This item displays the status of TPM Ownership.

5-4 Boot Configuration

Use this feature to configure boot settings.

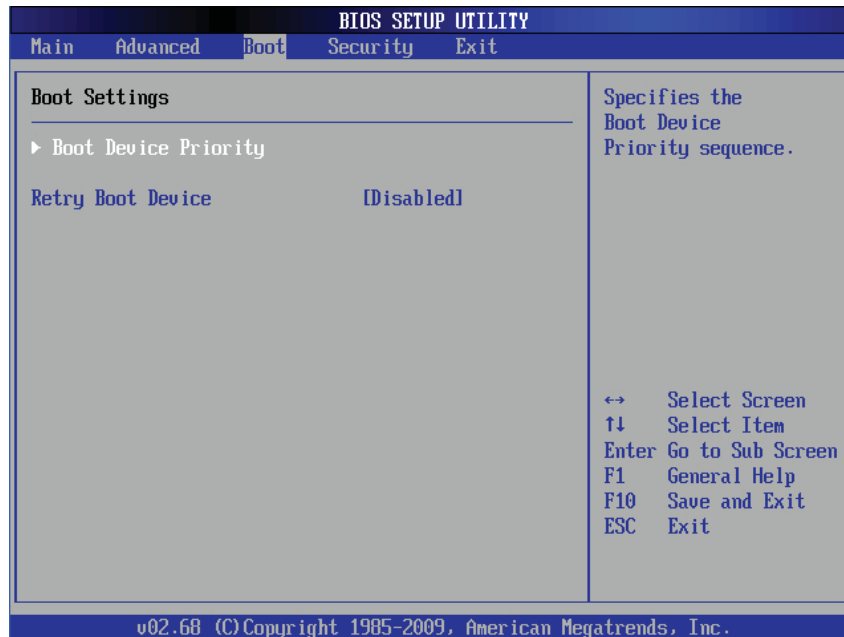

► Boot Device Priority

This feature allows the user to specify the sequence of priority for the Boot Device. The settings are 1st boot device, 2nd boot device, 3rd boot device, 4th boot device, 5th boot device and Disabled.

- 1st Boot Device - [SATA: XXXXXXXXXX]

► Hard Disk Drive, CD/DVD-ROM Drive, Removable Drive

This feature allows the user to specify the boot sequence from all available hard disk drives. The settings are Disabled and a list of all hard disk drives that have been detected (i.e., 1st Drive, 2nd Drive, 3rd Drive, etc).

- 1st Drive - [SATA: XXXXXXXXXX]

Retry Boot Devices

Select Enabled to enable Retry Boot Devices support to allow the system to attempt to boot from a specific boot device after a boot failure. The options are Enabled and **Disabled**.

5-5 Security Settings

The AMI BIOS provides a Supervisor and a User password. If you use both passwords, the Supervisor password must be set first.

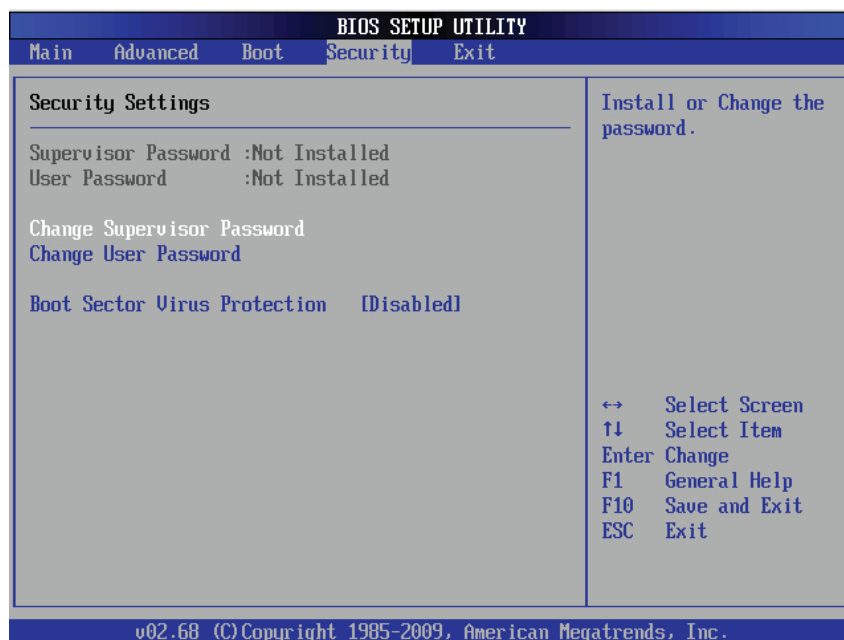

Supervisor Password

This item indicates if a Supervisor password has been entered for the system. "Not Installed" means a Supervisor password has not been used.

User Password

This item indicates if a user password has been entered for the system. "Not Installed" means that a user password has not been used.

Change Supervisor Password

Select this feature and press <Enter> to access the submenu, and then enter a new Supervisor Password.

User Access Level (Available when Supervisor Password is set as above)

Select **Full Access** to grant full User read and write access to the Setup Utility. Select View Only to allow the user to view the Setup Utility settings without changing the fields. Select Limited to allow the user to access and change limited fields such as Date and Time. Select No Access to prevent the user from accessing the Setup Utility.

Change User Password

Select this feature and press <Enter> to access the submenu and enter a new User Password.

Clear User Password (Available only when User Password has been set)

This item allows the user to clear a user password after it has been entered.

Password Check

Select Setup for the system to check for a password at Setup. Select Always for the system to check for a password at bootup. The options are **Setup** and Always.

Boot Sector Virus Protection

If this item is enabled, AMI BIOS displays a warning if any program (or virus) issues a Disk Format command or attempts to write to the boot sector of the hard disk drive. The options are Enabled and **Disabled**.

5-6 Exit Options

Select the Exit tab from the AMI BIOS Setup Utility screen to enter the Exit BIOS Setup screen.

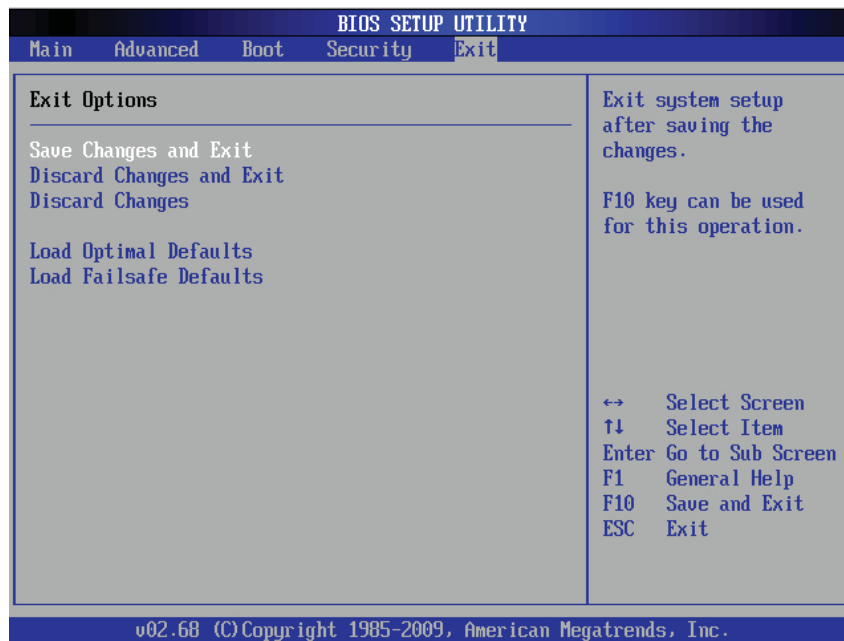

Save Changes and Exit

When you have completed the system configuration changes, select this option to leave the BIOS Setup Utility and reboot the computer so that the new system configuration parameters can take effect. Select Save Changes and Exit from the Exit menu and press <Enter>.

Discard Changes and Exit

Select this option to quit the BIOS Setup without making any permanent changes to the system configuration and reboot the computer. Select Discard Changes and Exit from the Exit menu and press <Enter>.

Discard Changes

Select this option and press <Enter> to discard all the changes and return to the AMI BIOS Utility Program.

Load Optimal Defaults

To set this feature, select Load Optimal Defaults from the Exit menu and press <Enter>. Then, select OK to allow the AMI BIOS to automatically load Optimal Defaults to the BIOS Settings. The Optimal settings are designed for maximum system performance but may not work best for all computer applications.

Load Fail-Safe Defaults

To set this feature, select Load Fail-Safe Defaults from the Exit menu and press <Enter>. The Fail-Safe settings are designed for maximum system stability but not for maximum performance.

Appendix A

BIOS Error Beep Codes

During the POST (Power-On Self-Test) routines, which are performed at each system boot, errors may occur.

Non-fatal errors are those which, in most cases, allow the system to continue to boot. The error messages normally appear on the screen.

Fatal errors will not allow the system to continue with bootup procedure. If a fatal error occurs, you should consult with your system manufacturer for possible repairs.

These fatal errors are usually communicated through a series of audible beeps. The numbers on the fatal error list correspond to the number of beeps for the corresponding error.

A-1 BIOS Error Beep Codes

BIOS Error Beep Codes		
Beep Code/LED	Error Message	Description
1 beep	Refresh	Circuits have been reset. (Ready to power up)
5 short beeps + 1 long beep	Memory error	No memory detected in the system
8 beeps	Display memory read/write error	Video adapter missing or with faulty memory
OH LED On	System OH	System Overheat

Notes

Appendix B

Software Installation Instructions

B-1 Installing Software Programs

After you've installed the operating system, a screen as shown below will appear. You are ready to install software programs and drivers that have not yet been installed. To install these programs, click the icons to the right of these items.

 **Note:** To install the Windows OS, please refer to the instructions posted on our Website at <http://www.supermicro.com/support/manuals/>.



Driver/Tool Installation Display Screen

 **Note 1.** Click the icons showing a hand writing on the paper to view the readme files for each item. Click a computer icon to the right of an item to install an item (from top to the bottom) one at a time. After installing each item, you must reboot the system before proceeding with the next item on the list. The bottom icon with a CD on it allows you to view the entire contents of the CD.

Note 2. When making a storage driver diskette by booting into a Driver CD, please set the SATA Configuration to "Compatible Mode" and configure SATA as IDE in the BIOS Setup. After making the driver diskette, be sure to change the SATA settings back to your original settings.

B-2 Configuring Supero Doctor III

The Supero Doctor III program is a web-based management tool that supports remote management capability. It includes Remote and Local Management tools. The local management is called the SD III Client. The Supero Doctor III program included on the CDROM that came with your motherboard allows you to monitor the environment and operations of your system. Supero Doctor III displays crucial system information such as CPU temperature, system voltages and fan status. See the Figure below for a display of the Supero Doctor III interface.



Note: 1 The default user name and password are ADMIN.

Note 2: In the Windows OS environment, the Supero Doctor III settings take precedence over the BIOS settings. When first installed, Supero Doctor III adopts the temperature threshold settings previously set in BIOS. Any subsequent changes to these thresholds must be made within Supero Doctor, since the SD III settings override the BIOS settings. For the Windows OS to adopt the BIOS temperature threshold settings, please change the SDIII settings to be the same as those set in BIOS.

Supero Doctor III Interface Display Screen-I (Health Information)



Supero Doctor III Interface Display Screen-II (Remote Control)



 **Note:** SD III Software Revision 1.0 can be downloaded from our website at: ftp://ftp.Supermicro.com/utility/Supero_Doctor_III/. You can also download SDIII User's Guide at: <http://www.supermicro.com/PRODUCT/Manuals/SDIII/UserGuide.pdf>. For Linux, we will still recommend that you use Supero Doctor II.

Notes

(Disclaimer Continued)

The products sold by Supermicro are not intended for and will not be used in life support systems, medical equipment, nuclear facilities or systems, aircraft, aircraft devices, aircraft/emergency communication devices or other critical systems whose failure to perform be reasonably expected to result in significant injury or loss of life or catastrophic property damage. Accordingly, Supermicro disclaims any and all liability, and should buyer use or sell such products for use in such ultra-hazardous applications, it does so entirely at its own risk. Furthermore, buyer agrees to fully indemnify, defend and hold Supermicro harmless for and against any and all claims, demands, actions, litigation, and proceedings of any kind arising out of or related to such ultra-hazardous use or sale.