

# SUPER<sup>®</sup>

SUPER P4SDA+  
SUPER P4SDM

USER'S MANUAL

Revision 1.0a

---

The information in this User's Manual has been carefully reviewed and is believed to be accurate. The vendor assumes no responsibility for any inaccuracies that may be contained in this document, makes no commitment to update or to keep current the information in this manual, or to notify any person or organization of the updates. **Please Note: For the most up-to-date version of this manual, please see our web site at [www.supermicro.com](http://www.supermicro.com).**

SUPERMICRO COMPUTER reserves the right to make changes to the product described in this manual at any time and without notice. This product, including software, if any, and documentation may not, in whole or in part, be copied, photocopied, reproduced, translated or reduced to any medium or machine without prior written consent.

IN NO EVENT WILL SUPERMICRO COMPUTER BE LIABLE FOR DIRECT, INDIRECT, SPECIAL, INCIDENTAL, OR CONSEQUENTIAL DAMAGES ARISING FROM THE USE OR INABILITY TO USE THIS PRODUCT OR DOCUMENTATION, EVEN IF ADVISED OF THE POSSIBILITY OF SUCH DAMAGES. IN PARTICULAR, THE VENDOR SHALL NOT HAVE LIABILITY FOR ANY HARDWARE, SOFTWARE, OR DATA STORED OR USED WITH THE PRODUCT, INCLUDING THE COSTS OF REPAIRING, REPLACING, INTEGRATING, INSTALLING OR RECOVERING SUCH HARDWARE, SOFTWARE, OR DATA.

Any disputes arising between manufacturer and customer shall be governed by the laws of Santa Clara County in the State of California, USA. The State of California, County of Santa Clara shall be the exclusive venue for the resolution of any such disputes. Supermicro's total liability for all claims will not exceed the price paid for the hardware product.

---

Unless you request and receive written permission from SUPER MICRO COMPUTER, you may not copy any part of this document.

Information in this document is subject to change without notice. Other products and companies referred to herein are trademarks or registered trademarks of their respective companies or mark holders.

Copyright © 2002 by SUPER MICRO COMPUTER INC.  
All rights reserved.

**Printed in the United States of America**

## Preface

### About This Manual

This manual is written for system integrators, PC technicians and knowledgeable PC users. It provides information for the installation and use of the SUPER P4SDA+/P4SDM motherboard. The SUPER P4SDA+/P4SDM supports single Intel Pentium® 4 1.50 - 2.20+ GHz processors at a system bus speed of 400 MHz. Please refer to the support section of our web site (<http://www.supermicro.com/TechSupport.htm>) for a complete listing of supported processors.

Single 478-pin Pentium 4 processors are housed in a 478-pin microPGA (Plastic Grid Array) package.

### Manual Organization

**Chapter 1** includes a checklist of what should be included in your mainboard box, describes the features, specifications and performance of the SUPER P4SDA+/P4SDM mainboard and provides detailed information about the chipset.

**Chapter 2** begins with instructions on handling static-sensitive devices. Read this chapter when you want to install the processor and DDR memory modules and when mounting the mainboard in the chassis. Also refer to this chapter to connect the floppy and hard disk drives, the IDE interfaces, the parallel and serial ports and the twisted wires for the power supply, the reset button, the keylock/power LED, the speaker and the keyboard.

If you encounter any problems, see **Chapter 3**, which describes troubleshooting procedures for the video, the memory and the setup configuration stored in CMOS. For quick reference, a general FAQ (Frequently Asked Questions) section is provided. Instructions are also included for contacting technical support. In addition, you can visit our web site at [www.supermicro.com/techsupport.htm](http://www.supermicro.com/techsupport.htm) for more detailed information.

**Chapter 4** includes an introduction to BIOS and provides detailed information on running the CMOS Setup utility.

**Appendix A** provides AwardBIOS POST Codes.

**Appendix B** lists AwardBIOS POST Messages.

**Appendix C** lists AwardBIOS Error Beep Codes.

---

---

## Table of Contents

### Preface

About This Manual .....	iii
Manual Organization .....	iii

### Chapter 1: Introduction

1-1 Overview .....	1-1
Checklist .....	1-1
Contacting Supermicro .....	1-2
SUPER P4SDA+ Image .....	1-4
SUPER P4SDM Image .....	1-5
SUPER P4SDA+ Layout .....	1-6
SUPER P4SDA+ Quick Reference .....	1-7
SUPER P4SDM Layout .....	1-8
SUPER P4SDM Quick Reference .....	1-9
845 Chipset: System Block Diagram .....	1-10
Motherboard Features .....	1-11
1-2 Chipset Overview .....	1-13
1-3 Special Features .....	1-14
1-4 PC Health Monitoring .....	1-14
1-5 ACPI/PC 99 Features .....	1-16
1-6 Power Supply .....	1-18
1-7 Super I/O .....	1-18

### Chapter 2: Installation

2-1 Static-Sensitive Devices .....	2-1
2-2 Processor and Heatsink Installation .....	2-2
2-3 Mounting the Motherboard in the Chassis .....	2-4
2-4 Installing DDR Memory .....	2-5
2-5 I/O Port/Front Control Panel Connector Locations .....	2-6
2-6 Connecting Cables .....	2-8
Power Supply Connector .....	2-8
IR Connector .....	2-9
PW_ON .....	2-9
Reset .....	2-9
IDE LED .....	2-9
Power_LED .....	2-10
Keylock .....	2-10
Speaker .....	2-10

---

Serial Ports .....	2-10
CD Headers .....	2-11
Fan Headers .....	2-11
Chassis Intrusion Header .....	2-11
Overheat LED .....	2-11
ATX PS/2 Keyboard/Mouse Ports .....	2-12
Universal Serial Bus .....	2-12
Wake-On-LAN .....	2-12
Wake-On-Ring .....	2-13
2-7 Jumper Settings .....	2-14
Explanation of Jumpers .....	2-14
CMOS Clear .....	2-14
AC'97 Enable/Disable .....	2-15
USB Wake-Up .....	2-15
Watch Dog Enable/Disable .....	2-15
Keyboard Wake-Up .....	2-16
2-8 Game Port, Parallel Port, Floppy/Hard Drive and AGP Connections ...	2-16
Game Port Connector .....	2-17
Parallel Port Connector .....	2-17
Floppy Connector .....	2-17
IDE Connectors .....	2-18
AGP Slot .....	2-18
2-9 Installing Software Drivers .....	2-19
 <b>Chapter 3: Troubleshooting</b>	
3-1 Troubleshooting Procedures .....	3-1
Before Power On .....	3-1
No Power .....	3-1
No Video .....	3-1
Memory Errors .....	3-2
Losing the System's Setup Configuration .....	3-2
3-2 Technical Support Procedures .....	3-2
3-3 Frequently Asked Questions .....	3-3
3-4 Returning Merchandise for Service .....	3-6
 <b>Chapter 4: AwardBIOS</b>	
4-1 Introduction .....	4-1
4-2 Running Setup .....	4-2
4-3 Main BIOS Setup .....	4-2

---

	Main BIOS Setup Menu .....	4-3
4-4	Advanced BIOS Setup .....	4-6
	4-4.1 Advanced BIOS Features .....	4-6
	4-4.2 Advanced Chipset Features .....	4-9
	4-4.3 Integrated Peripherals .....	4-15
	4-4.4 Hardware Monitors .....	4-18
	4-4.5 Processor Features .....	4-19
4-5	PCI/PnP Configurations .....	4-20
4-6	Power .....	4-22
4-7	Boot .....	4-25
4-8	Security .....	4-27
4-9	Exit .....	4-28

**Appendices:**

	Appendix A: AwardBIOS POST Messages .....	A-1
	Appendix B: AwardBIOS POST Codes .....	B-1
	Appendix C: AwardBIOS Error Beep Codes .....	C-1

# Chapter 1

## Introduction

### 1-1 Overview

#### Checklist

Congratulations on purchasing your computer motherboard from an acknowledged leader in the industry. Supermicro boards are designed with the utmost attention to detail to provide you with the highest standards in quality and performance.

Please check that the following items have all been included with your motherboard. If anything listed here is damaged or missing, contact your retailer.

One (1) Supermicro Mainboard

One (1) ATA66/100 ribbon cable for IDE devices

One (1) floppy ribbon cable for (1) 5.25-inch floppy and (2) 3.5-inch floppy drives

One (1) Supermicro CD or diskettes containing drivers and utilities

One (1) CPU heatsink fan and clips (retail only)

One (1) User's/BIOS Manual

One (1) CPU heat sink bracket

One (1) USB cable with one port (retail only)

## Contacting Supermicro

### Headquarters

Address: Super Micro Computer, Inc.  
980 Rock Ave.  
San Jose, CA 95131 U.S.A.

Tel: +1 (408) 503-8000

Fax: +1 (408) 503-8008

E-mail: [marketing@supermicro.com](mailto:marketing@supermicro.com) (General Information)  
[support@supermicro.com](mailto:support@supermicro.com) (Technical Support)

Web site: [www.supermicro.com](http://www.supermicro.com)

### European Office

Address: Super Micro Computer B.V.  
Het Sterrenbeeld 28, 5215 ML,  
's-Hertogenbosch, The Netherlands

Tel: +31 (0) 73-6400390

Fax: +31 (0) 73-6416525

E-mail: [sales@supermicro.nl](mailto:sales@supermicro.nl) (General Information)  
[support@supermicro.nl](mailto:support@supermicro.nl) (Technical Support)  
[rma@supermicro.nl](mailto:rma@supermicro.nl) (Customer Support)

### Asia-Pacific

Address: 3F, #753 Chung-Cheng Road  
Chung-Ho City, Taipei Hsien, Taiwan, R.O.C.

Tel: +886-(2) 8228-1366

Fax: +886-(2) 8221-2790

www: [www.supermicro.com.tw](http://www.supermicro.com.tw)

Email: [support@supermicro.com.tw](mailto:support@supermicro.com.tw)

Technical Support:  
Tel: 886-2-8228-1366, ext.132

## Notes

## SUPER P4SDA+

Figure 1-1. SUPER P4SDA+ Image

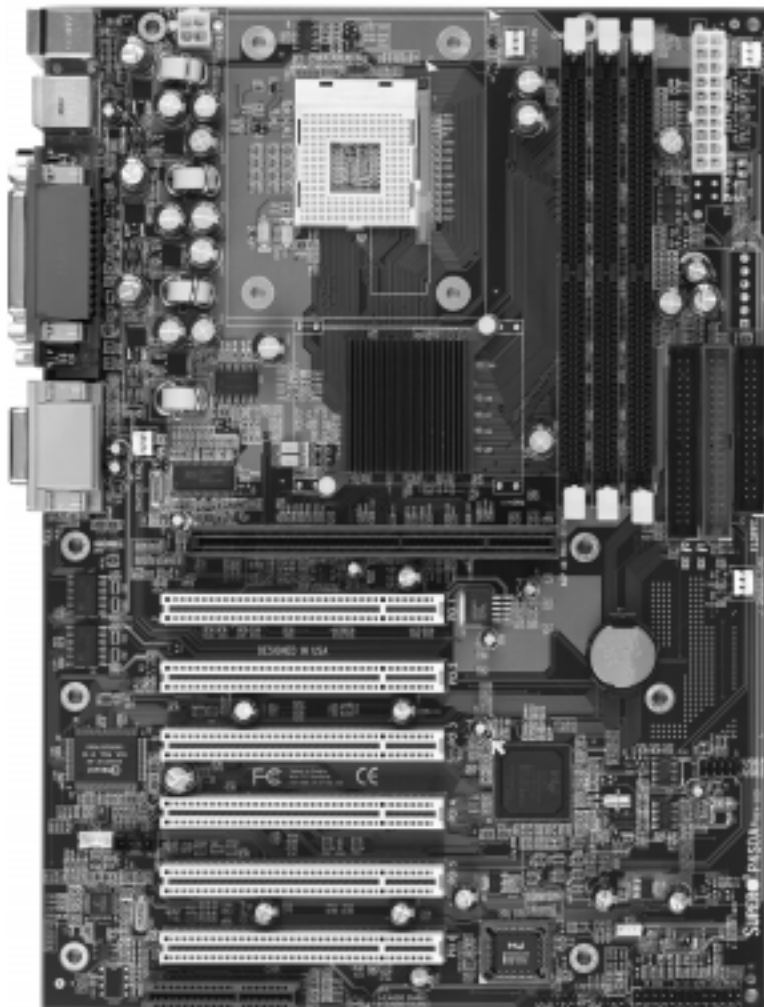

## SUPER P4SDM

Figure 1-2. SUPER P4SDM Image

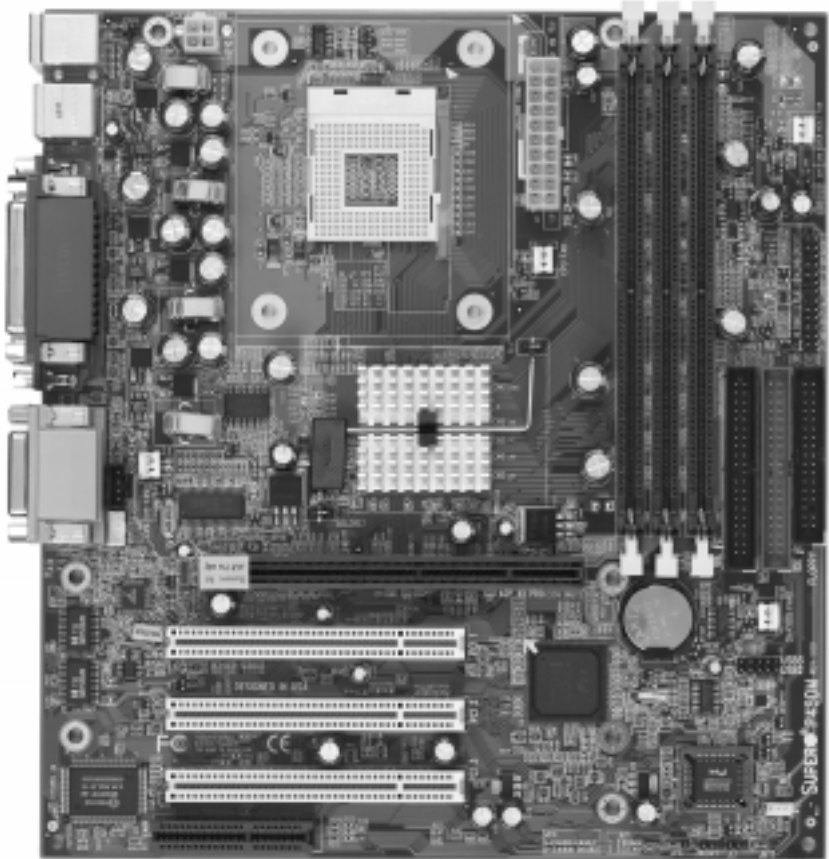

**Figure 1-3. SUPER P4SDA+ Layout**  
(not drawn to scale)

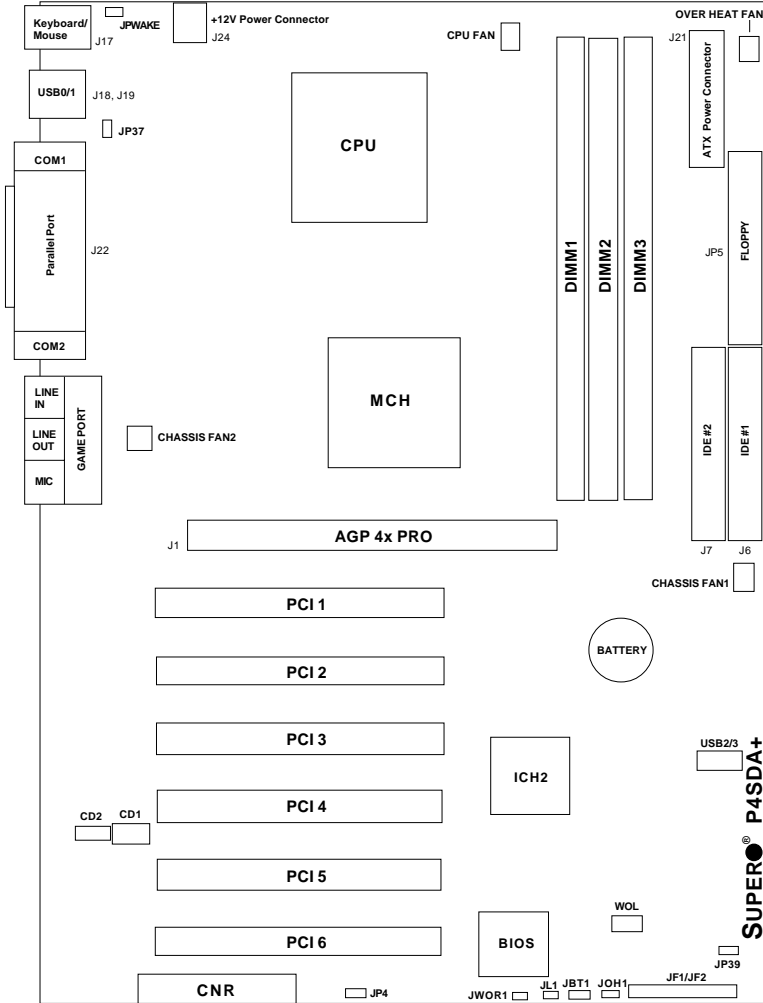

## P4SDA+ Quick Reference

<b><u>Jumpers</u></b>	<b><u>Description</u></b>	<b><u>Default Setting</u></b>
JBT1	CMOS Clear	Pins 1-2 (Normal)
JP4	AC97 Audio Enable	Pins 1-2 (Enabled)
JP37	USB Wake Up	Pins 1-2 (Disabled)
JP39	Watch Dog Enable	Open (Disabled)
JPWAKE	Keyboard Wake-Up	Pins 1-2 (Disabled)

<b><u>Connectors</u></b>	<b><u>Description</u></b>
CD1	Audio CD Input (large connector)
CD2	Audio CD Input (small connector)
CNR	Communications/Networking Riser
COM1/COM2	COM1/COM2 Serial Port Connector
CPU Fan	CPU Fan Header
Chassis Fan1/2	Chassis Fan Header
Over Heat Fan	Thermal Control Backup Fan Header
DIMM1/2/3	Memory (DIMM) Slots
J1	AGP 4xPRO
J6, J7	IDE Hard Disk Drive Connectors
J21, J24*	ATX 12V Power Connector (20-pin, 4pin)
J17	PS/2 Keyboard/Mouse
J18, J19	Universal Serial Bus Ports #0/#1
J22	Parallel Printer Port
JF1, JF2	Front Control Panel
JL1	Chassis Intrusion Header
JOH 1	Overheat LED
JP5	Floppy Disk Drive Connector
JWOR1	Wake-On-Ring Header
GAME PORT	Game Port
LINE IN	Audio In Connector
LINE OUT	Audio Out (Speaker) Connector
MIC	Microphone Input
USB2/3	Universal Serial Bus Port #2/#3
WOL	Wake-On-LAN

\* The 4-pin connector at J24 must be connected to meet the safety requirements of the ATX 12V specifications.

See Chapter 2 for detailed information on jumpers, I/O ports and JF1/JF2 Front Panel Connections. Jumpers not indicated are for test purposes only.

**Figure 1-4. SUPER P4SDM Layout**  
(not drawn to scale)

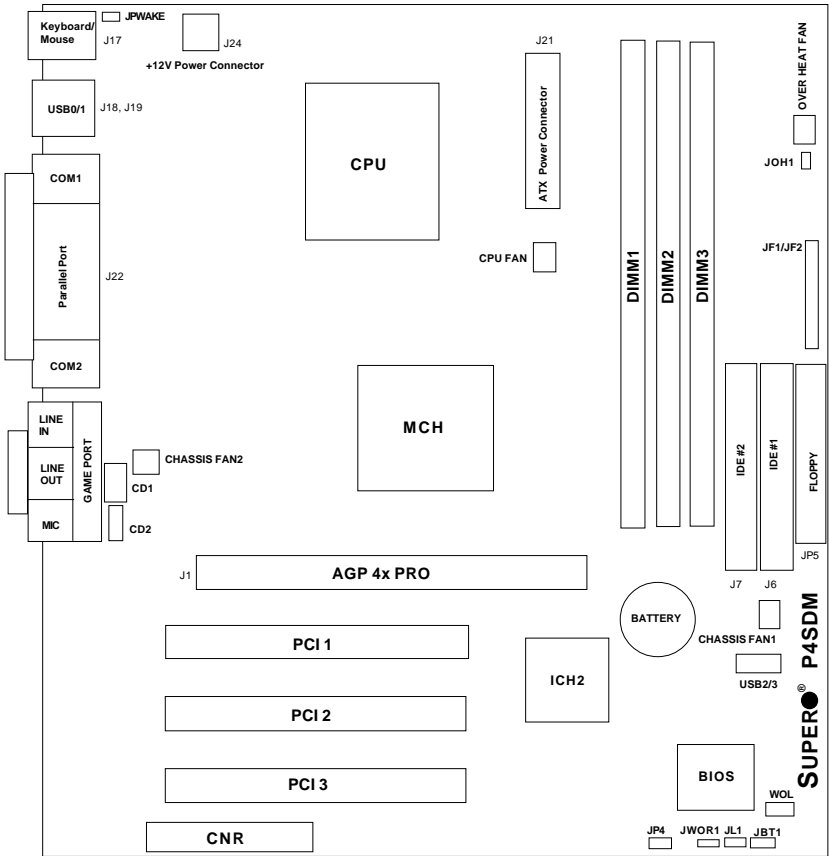

## P4SDM Quick Reference

<b><u>Jumpers</u></b>	<b><u>Description</u></b>	<b><u>Default Setting</u></b>
JBT1	CMOS Clear	Pins 1-2 (Normal)
JP4	AC97 Audio Enable	Pins 1-2 (Enabled)
JPWAKE	Keyboard Wake-Up	Pins 1-2 (Disabled)

<b><u>Connectors</u></b>	<b><u>Description</u></b>
CD1	Audio CD Input (large connector)
CD2	Audio CD Input (small connector)
CNR	Communications/Networking Riser
COM1/COM2	COM1/COM2 Serial Port Connector
CPU Fan	CPU Fan Header
Chassis Fan1/2	Chassis Fan Header
Over Heat Fan	Thermal Control Backup Fan Header
DIMM1/2/3	Memory (DIMM) Slots
J1	AGP 4xPRO
J6, J7	IDE Hard Disk Drive Connectors
J21, J24*	ATX 12V Power Connector (20-pin, 4pin)
J16	Parallel Printer Port
J17	PS/2 Keyboard/Mouse
J18, J19	Universal Serial Bus Ports #0/#1
JF1, JF2	Front Control Panel
JL1	Chassis Intrusion Header
JOH 1	Overheat LED
JP5	Floppy Disk Drive Connector
JWOR1	Wake-On-Ring Header
GAME PORT	Game Port
LINE IN	Audio In Connector
LINE OUT	Audio Out (Speaker) Connector
MIC	Microphone Input
USB2/3	Universal Serial Bus Port #2/#3
WOL	Wake-On-LAN

\* The 4-pin connector at J24 must be connected to meet the safety requirements of the ATX 12V specifications.

See Chapter 2 for detailed information on jumpers, I/O ports and JF1/JF2 Front Panel Connections. Jumpers not indicated are for test purposes only.

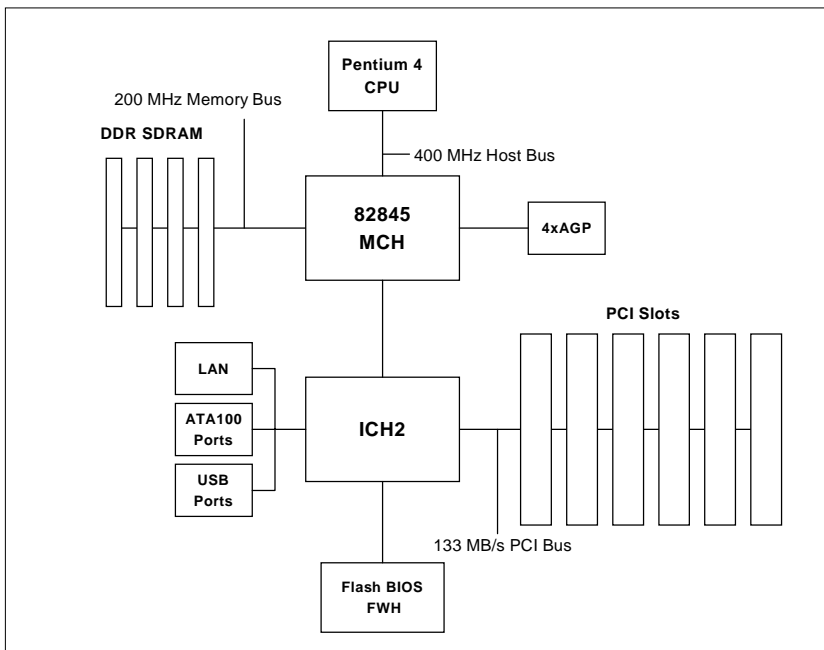

**Figure 1-5. 845 Chipset:  
System Block Diagram**

---

**Note:** This is a general block diagram and may not exactly represent the features on your motherboard. See the following pages for the actual specifications of each motherboard.

---

## Features of the P4SDA+/P4SDM Motherboard

### **CPU**

- Single Pentium® 4 478-pin micro FCPGA 1.50 to 2.20+ GHz processors at a 400 MHz system bus speed

### **Memory**

- Three 184-pin DDR DIMMs for up to 2 GB of unbuffered PC1600 and PC2100 SDRAM. Error Checking & Correction and Parity Checking are fully supported.

**Note:** See Section 2-4 for restrictions on installing memory.

### **Chipset**

- Intel 845 Chipset

### **Expansion Slots**

- Six 32-bit, 33 MHz PCI slots (P4SDA+)
- Three 32-bit, 33 MHz PCI slots (P4SDM)
- One 4xAGP Pro (1.5V only) slot
- One CNR (Communications and Network Riser Card) slot

### **BIOS**

- 4 Mb Firmware Hub AwardBIOS® Flash BIOS
- APM 1.2, DMI 2.3, PCI 2.2, ACPI 1.0, Plug and Play (PnP)

### **PC Health Monitoring**

- Onboard voltage monitors for CPU core, chipset voltage, +3.3V, +5V and  $\pm 12V$
- Three-fan status monitor with firmware/software on/off control
- Environmental temperature monitoring and control
- CPU fan auto-off in sleep mode
- Power-up mode control for recovery from AC power loss
- System overheat LED and control
- System resource alert
- Hardware BIOS virus protection
- Auto-switching voltage regulator for the CPU core

### **ACPI/PC98 Features**

- Microsoft OnNow
- Slow blinking LED for suspend state indicator

- BIOS support for USB keyboard
- Real-time clock wake-up alarm
- Main switch override mechanism
- External modem ring-on

### **Onboard I/O**

- Dual Ultra DMA 100 IDE Bus Masters
- 1 floppy port interface (up to 2.88 MB)
- 2 Fast UART 16550A compatible serial ports
- 1 EPP (Enhanced Parallel Port) and ECP (Extended Capabilities Port) supported parallel port
- PS/2 mouse and PS/2 keyboard ports
- 1 game port with audio
- Up to 4 USB (Universal Serial Bus) ports

### **Other**

- Internal/external modem ring-on
- Recovery from AC power loss control
- Wake-on-LAN (WOL)
- Multiple CPU clock frequency ratio selections (set in BIOS)

### **CD Utilities**

- BIOS flash upgrade utility
- Drivers for 845 chipset utilities

### **Dimensions**

- P4SDA+: ATX, 12" x 8.7" (305 x 220 mm)
- P4SDM: microATX: 9.6" x 8.9" (244 x 226 mm)

## 1-2 Chipset Overview

Intel's 845 chipset is made up of three main components:

The 82845 Memory Controller Hub (MCH) with an Accelerated Hub Architecture (AHA) bus, the 82801 BA I/O Controller Hub (ICH2) with an AHA bus and the 82802 AB Firmware Hub (FWH).

### **Memory Controller Hub (MCH)**

The MCH includes the host (CPU) interface, memory interface, ICH2 interface and 4xAGP interface for the 845 chipset. It contains advanced power management logic and supports three DIMMS for up to 2 GB of unbuffered DDR RAM. The AGP 2.0 interface supports 4x data transfers and operates at a peak bandwidth of 1056 GB. The MCH host (front side bus) interface bus runs at 400 MHz.

### **I/O Controller Hub (ICH2)**

The ICH2 is the I/O Controller Hub subsystem on the P4SDA/P4SDM, which integrates many of the input/output functions of the 845 chipset, including a two-channel ATA100 Bus Master IDE controller. It also provides the interface to the PCI Bus and communicates with the MCH over a dedicated hub interface bus -- the AHA. The P4SDA+/P4SDM features the ICH2, which includes a dual channel IDE controller plus two USB controllers that offer 24 Mbps of bandwidth across four ports. ICH2 also features an enhanced AC97 interface that supports full surround sound for the Dolby Digital Audio used on DVDs.

### **Firmware Hub (FWH)**

The FWH is a component that brings added security and manageability to the PC platform infrastructure. This device includes an integrated Random Number Generator (RNG) for stronger encryption, digital signing and security protocols. The FWH stores the system BIOS and video BIOS to eliminate a redundant nonvolatile memory component.

## **Recovery from AC Power Loss**

The BIOS provides a setting for you to determine how the system will respond when AC power is lost and then restored to the system. You can choose for the system to remain powered off (in which case you must hit the power switch to turn it back on) or for it to automatically return to a power on state. See the Power Lost Control setting in the BIOS chapter of this manual to change this setting. The default setting is Always OFF.

## **1-3 Special Features**

### **Communication and Networking Riser**

The CNR slot supports audio, modem and networking cards and provides interfaces that support multichannel audio, V.90 analog modems, home networking through a telephone line, 10/100 Ethernet-based networking and future technologies. Separating sound and communications systems from the motherboard makes them less sensitive to noise.

## **1-4 PC Health Monitoring**

This section describes the PC health monitoring features of the SUPER P4SDA+/P4SDM. Both have an onboard System Hardware Monitor chip that supports PC health monitoring.

### **Onboard Voltage Monitors for the CPU Core, Chipset Voltage, +3.3V, +5V and $\pm$ 12V**

The onboard voltage monitor will scan these voltages continuously. Once a voltage becomes unstable, it will give a warning or send an error message to the screen. Users can adjust the voltage thresholds to define the sensitivity of the voltage monitor.

### **Three-Fan Status Monitor with Firmware/Software On/Off Control**

The PC health monitor can check the RPM status of the cooling fans. The onboard 3-pin CPU and chassis fans are controlled by the power management functions. The thermal fan is controlled by the overheat detection logic.

### **Environmental Temperature Control**

The thermal control sensor monitors the CPU temperature in real time and will turn on the thermal control fan whenever the CPU temperature exceeds a user-defined threshold. The overheat circuitry runs independently from the CPU. It can continue to monitor for overheat conditions even when the CPU is in sleep mode. Once it detects that the CPU temperature is too high, it will automatically turn on the thermal control fan to prevent any overheat damage to the CPU. The onboard chassis thermal circuitry can monitor the overall system temperature and alert users when the chassis temperature is too high.

### **CPU Fan Auto-Off in Sleep Mode**

The CPU fan activates when the power is turned on. It can be turned off when the CPU is in sleep mode. When in sleep mode, the CPU will not run at full power, thereby generating less heat.

### **CPU Overheat LED and Control**

This feature is available when the user enables the CPU overheat warning function in the BIOS. This allows the user to define an overheat temperature. When this temperature is exceeded, both the overheat fan and the warning LED are turned on.

### **System Resource Alert**

This feature is available when used with Intel's LANDesk Client Manager (optional). It is used to notify the user of certain system events. For example, if the system is running low on virtual memory and there is insufficient hard drive space for saving the data, you can be alerted of the potential problem.

## Hardware BIOS Virus Protection

The system BIOS is protected by hardware so that no virus can infect the BIOS area. The user can only change the BIOS content through the flash utility provided by Supermicro. This feature can prevent viruses from infecting the BIOS area and destroying valuable data.

## Auto-Switching Voltage Regulator for the CPU Core

The 3-phase-switching voltage regulator for the CPU core can support up to 60A current and auto-sense voltage IDs ranging from 1.1V to 1.85V. This will allow the regulator to run cooler and thus make the system more stable.

## 1-5 ACPI/PC99 Features

ACPI is an acronym for Advanced Configuration and Power Interface. The ACPI specification defines a flexible and abstract hardware interface that provides a standard way to integrate power management features throughout a PC system, including its hardware, operating system and application software. This enables the system to turn on and off peripherals such as CD-ROMs, network cards, hard disk drives and printers automatically. This also includes consumer devices connected to the PC such as VCRs, TVs, telephones and stereos.

In addition to enabling operating system-directed power management, ACPI provides a generic system event mechanism for Plug and Play and an operating system-independent interface for configuration control. ACPI leverages the Plug and Play BIOS data structures while providing a processor architecture-independent implementation that is compatible with both Windows 98/2000 and Windows NT 4.0. **Note:** To utilize ACPI, you must reinstall Windows 98. To reinstall Windows 98 with ACPI, enter DOS and type "setup /p J" at the CDROM prompt (usually D:\) with the Windows 98 CD loaded. (Make sure you include the spaces after "setup" and "p".) Then press <Enter>. You can check to see if ACPI has been properly installed by looking for it in the Device Manager, which is located in the Control Panel in Windows.

## Microsoft OnNow

The OnNow design initiative is a comprehensive, system-wide approach to system and device power control. OnNow is a term for a PC that is always on but appears to be off and responds immediately to user or other re-

quests.

### **Slow Blinking LED for Suspend-State Indicator**

When the CPU goes into a suspend state, the chassis power LED will start blinking to indicate that the CPU is in suspend mode. When the user presses any key, the CPU will wake-up and the LED will automatically stop blinking and remain on.

### **BIOS Support for USB Keyboard**

If the USB keyboard is the only keyboard in the system, it keyboard will function like a normal keyboard during system boot-up.

### **Real Time Clock Wake-Up Alarm**

Although the PC may be perceived to be off when not in use, it is still capable of responding to preset wake-up events. In the BIOS, the user can set a timer to wake-up the system at a predetermined time.

### **Main Switch Override Mechanism**

When an ATX power supply is used, the power button can function as a system suspend button. When the user depresses the power button, the system will enter a SoftOff state. The monitor will be suspended and the hard drive will spin down. Depressing the power button again will cause the whole system to wake-up. During the SoftOff state, the ATX power supply provides power to keep the required circuitry in the system alive. In case the system malfunctions and you want to turn off the power, just depress and hold the power button for 4 seconds. The power will turn off and no power will be provided to the motherboard.

### **Wake-On-Ring Header**

Wake-up events can be triggered by a device such as the external modem ringing when the system is in the SoftOff state. Note that external modem ring-on can only be used with an ATX 2.01 (or above) compliant power supply.

## **Wake-On-LAN (WOL)**

Wake-On-LAN is defined as the ability of a management application to remotely power up a computer that is powered off. Remote PC setup, updates and asset tracking can occur after hours and on weekends so that daily LAN traffic is kept to a minimum and users are not interrupted. The motherboards have a 3-pin header (WOL) to connect to the 3-pin header on a Network Interface Card (NIC) that has WOL capability. Wake-On-LAN must be enabled in BIOS. Note that Wake-On-Lan can only be used with an ATX 2.01 (or above) compliant power supply.

## **1-6 Power Supply**

As with all computer products, a stable power source is necessary for proper and reliable operation. It is even more important for processors that have high CPU clock rates of 1.4+ GHz.

The SUPER P4SDA+/P4SDM accommodates 12V ATX power supplies. Although most power supplies generally meet the specifications required by the CPU, some are inadequate.

It is strongly recommended that you use a high quality power supply that meets 12V ATX power supply Specification 1.1 or above. Additionally, in areas where noisy power transmission is present, you may choose to install a line filter to shield the computer from noise. It is recommended that you also install a power surge protector to help avoid problems caused by power surges.

## **1-7 Super I/O**

The disk drive adapter functions of the Super I/O chip include a floppy disk drive controller that is compatible with industry standard 82077/765, a data separator, write pre-compensation circuitry, decode logic, data rate selection, a clock generator, drive interface control logic and interrupt and DMA logic. The wide range of functions integrated onto the Super I/O greatly reduces the number of components required for interfacing with floppy disk drives. The Super I/O supports four 360 K, 720 K, 1.2 M, 1.44 M or 2.88 M disk drives and data transfer rates of 250 Kb/s, 500 Kb/s or 1 Mb/s.

It also provides two high-speed, 16550 compatible serial communication ports (UARTs), one of which supports serial infrared communication. Each UART includes a 16-byte send/receive FIFO, a programmable baud rate generator, complete modem control capability and a processor interrupt system. Both UARTs provide legacy speed with baud rate of up to 115.2 Kbps as well as an advanced speed with baud rates of 250 K, 500 K, or 1 Mb/s, which support higher speed modems.

The Super I/O provides functions that comply with ACPI (Advanced Configuration and Power Interface), which includes support of legacy and ACPI power management through a SMI or SCI function pin. It also features auto power management to reduce power consumption.

The IRQs, DMAs and I/O space resources of the Super I/O can be flexibly adjusted to meet ISA PnP requirements, which support ACPI and APM (Advanced Power Management).

**Notes**

## Chapter 2 Installation

### 2-1 Static-Sensitive Devices

Electric Static Discharge (ESD) can damage electronic components. To prevent damage to your system board, it is important to handle it very carefully. The following measures are generally sufficient to protect your equipment from ESD.

#### Precautions

- Use a grounded wrist strap designed to prevent static discharge.
- Touch a grounded metal object before removing the board from the anti-static bag.
- Handle the board by its edges only; do not touch its components, peripheral chips, memory modules or gold contacts.
- When handling chips or modules, avoid touching their pins.
- Put the motherboard and peripherals back into their antistatic bags when not in use.
- For grounding purposes, make sure your computer chassis provides excellent conductivity between the power supply, the case, the mounting fasteners and the motherboard.

#### Unpacking

The motherboard is shipped in antistatic packaging to avoid static damage. When unpacking the board, make sure the person handling it is static protected.

#### Installation Procedures

Follow the procedures below for the installation of the motherboard and the system:

1. Installing the processor and the heat sink.
2. Installing the motherboard in the chassis.
3. Installing the memory and add-on cards.
4. Finally, installing the cables and drivers.

## 2-2 Processor and Heatsink Fan Installation



*When handling the processor package, avoid placing direct pressure on the label area of the fan.*

**IMPORTANT:** Always connect the power cord last and always remove it before adding, removing or changing any hardware components. Make sure that you install the processor into the CPU socket before you install the CPU heatsink.

### Installation of the Processor and Heatsink

1. Locate the following components, which are included in the shipping package.



**Note:** The CPU heatsink fan with clips is included only with the retail versions of the P4SDA+ and P4SDM. If you buy a boxed Intel Pentium 4 478/Northwood processor, it should include a heatsink, fan and retention mechanism. If you buy a processor separately, use only a Supermicro or Intel certified heatsink and fan.

2. Insert the white pegs into the black anchors. Do not force the white pegs all the way in - about 1/3 of the white pegs should be inside the black anchors. (These are for chassis that do not have four CPU retention holes.)



Bracket in position

3. Place a retention bracket in the proper position and secure it by pressing two pegs into the retention holes until you hear a \*click\*. The clicking sound indicates that the peg is locked and secured.

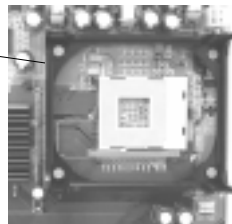

4. Secure the other retention bracket into position by repeating Step 3.

5. Lift the lever on the CPU socket.

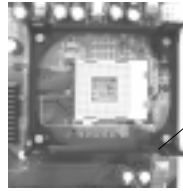

Socket Lever

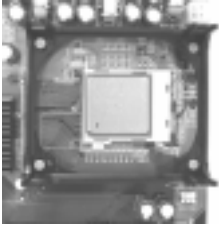

6. Install the CPU in the socket. Make sure that Pin 1 of the CPU is seated on Pin 1 of the socket (both corners are marked with a triangle).

7. Press the lever down until you hear it \*click\* into the locked position.

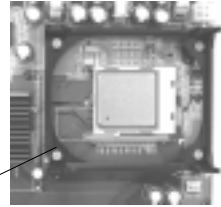

Socket lever in locked position

8. Apply the proper amount of thermal compound to the CPU die.

9. Place the heatsink on top of the CPU and press firmly downward - do not twist or slide the heatsink to seat thermal compound.

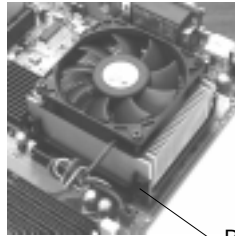

Retainer clip attachment point

10. Secure the heat sink by locking the retention clips into their proper position.

11. Connect the CPU fan cable to the proper CPU fan connector.



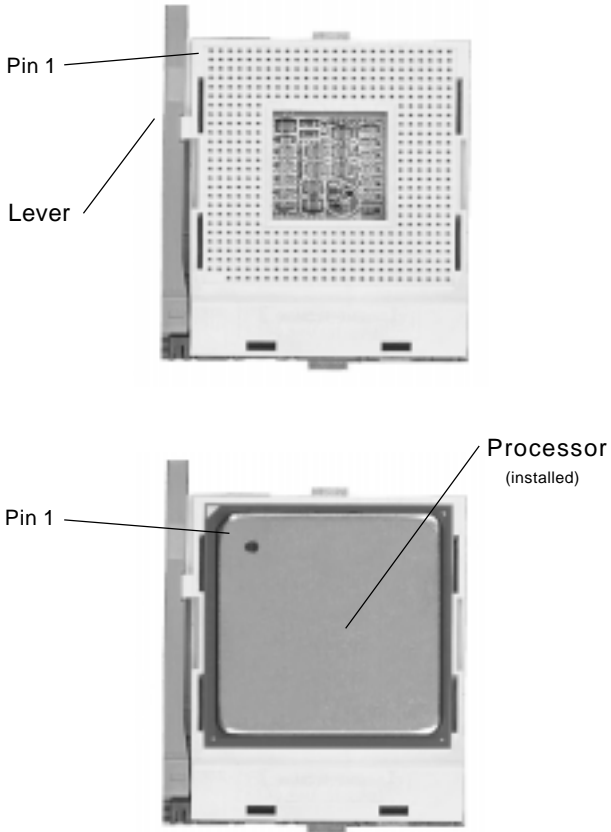

**Figure 2-1. 478-pin microPGA Socket: Empty and with Processor Installed**

### **2-3 Mounting the Motherboard in the Chassis**

All motherboards have standard mounting holes to fit different types of chassis. Chassis may include a variety of mounting fasteners made of metal or plastic.

## 2-4 Installing DDR Memory

### **CAUTION**

Exercise extreme care when installing or removing memory modules to prevent any possible damage.

### **Memory Module Installation (See Figure 2-2)**

1. Insert each DDR memory module vertically into its slot. Pay attention to the notch along the bottom of the module to prevent inserting the module incorrectly. (See support information below.)
2. Gently press down on the memory module until it snaps into place.
3. Three 184-pin memory sockets support up to 2 GB unbuffered PC1600 and PC2100 DDR SDRAM. ECC type memory is supported.

### **Support**

The P4SDA+/P4SDM supports both double-sided and single-sided unbuffered PC1600 and PC2100 DDR SDRAM memory modules. You should always populate DIMM1 first. DIMM1 can accept either a single or a double sided module. If you are using at least one double, put it into DIMM1. Then, if you are adding another double, it should go in DIMM2 and DIMM3 must remain empty. Or, you may populate both DIMM2 and DIMM3 with singles after DIMM1 is already populated.

**Figure 2-2a. Side View of DDR Module Installation into Slot**

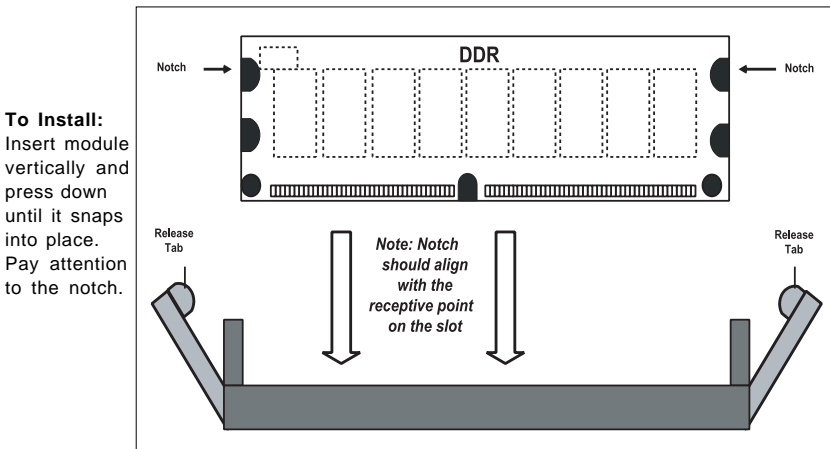

**Figure 2-2b. Release Tabs on DIMM Slot**

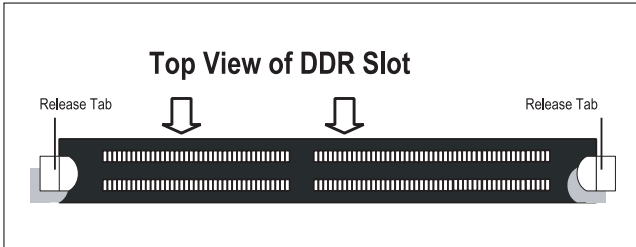

**To Remove:**

Use your thumbs gently to push each release tab outward to release the DIMM from the slot.

## 2-5 I/O Port/Control Panel Connector Locations

The I/O ports are color coded in conformance with the PC99 specification to make setting up your system easier. See Figure 2-3 below for the colors and locations of the various IO ports.

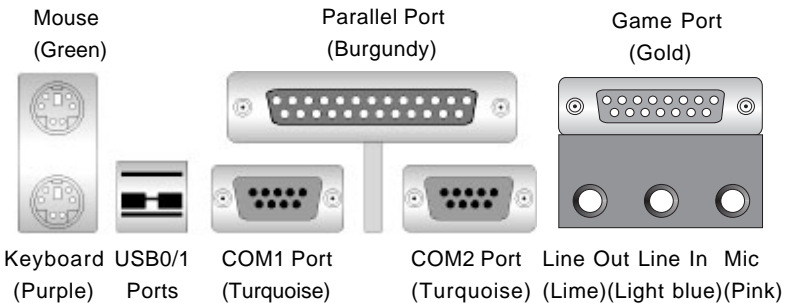

**Figure 2-3. I/O Port Locations and Definitions**

## Front Control Panel

JF1 and JF2 contain header pins for various front control panel connectors. See Figure 2-4 for the pin definitions of the speaker, keyboard lock, hard drive LED, infrared connector, and power on and reset button headers, which are all located on JF1 and JF2. Refer to Section 2-6 for details.

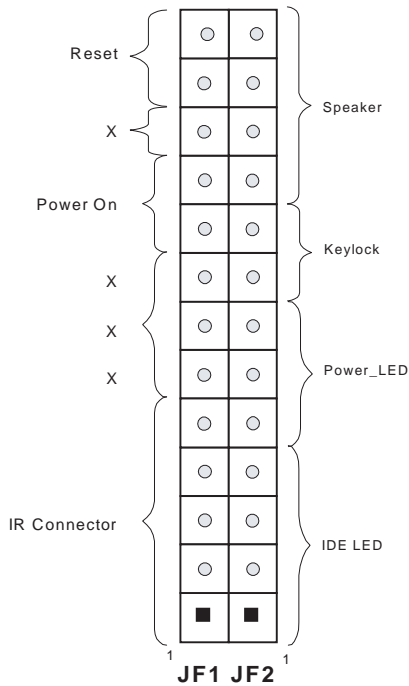
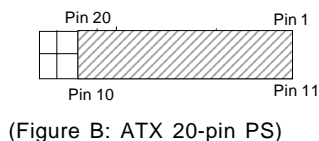
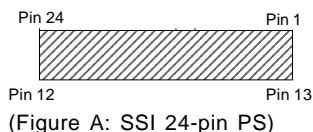

**Figure 2-4. Front Control Panel Connectors**

## 2-6 Connecting Cables

### Power Supply Connector

The primary power supply connector on the P4SDA+/P4SDM meets the SSI (Superset ATX) 24-pin specification, however it also supports ATX 20-pin connectors. Thus, both 20-pin ATX and 24-pin SSI connectors can be used as long as the PS connector is correctly oriented (make sure that pin 1 of the PS connector is seated on pin 1 of the J21 header). Refer to the tables on the right for the pin definitions of both 24 and 20-pin connectors. (Also see Figures A and B below for connector orientation.) Refer to the table below right for J24 (12V connector).



**ATX Power Supply 24-pin Connector  
Pin Definitions (J21)**

Pin Number	Definition	Pin Number	Definition
13	+3.3V	1	+3.3V
14	-12V	2	+3.3V
15	COM	3	COM
16	PS_ON#	4	+5V
17	COM	5	COM
18	COM	6	+5V
19	COM	7	COM
20	Res(NC)	8	PWR_OK
21	+5V	9	5VSB
22	+5V	10	+12V
23	+5V	11	+12V
24	COM	12	+3.3V

**ATX Power Supply 20-pin Connector  
(J21)**

Pin Number	Definition	Pin #	Definition
11	+3.3V	1	+3.3V
12	-12V	2	+3.3V
13	COM	3	COM
14	PS_ON	4	+5V
15	COM	5	COM
16	COM	6	+5V
17	COM	7	COM
18	-5V	8	PW-OK
19	+5V	9	5VSB
20	+5V	10	+12V

**+12V PWR Supply  
Connector  
(J24)**

**required  
connection**

Pins #	Definition
1 & 2 3 & 4	Ground +12 V

**PWR Supply  
Color Definition**

Color	Definition
Orange	+3.3V
Black	Com
Red	5V
White	Power OK
Yellow	+12V
Purple	5V standby
Brown	-5V

(For reference only)

## IR Connector

The infrared connector is located on pins 1-5 of JF1. See the table on the right for pin definitions. See the Technical Support section of our web page for information on the infrared devices you can connect to the system.

**Infrared Pin  
Definitions  
(JF1)**

Pin Number	Definition
1	+5V
2	Key
3	IRRX
4	Ground
5	IRTX

## PW\_ON Connector

The PW\_ON connector is located on pins 9 and 10 of JF1. Momentarily contacting both pins will power on/off the system. The user can also configure this button to function as a suspend button. (See the Power Button Mode setting in BIOS.) To turn off the power when set to suspend mode, hold down the power button for at least 4 seconds. See the table on the right for pin definitions.

**PW\_ON  
Pin Definitions  
(JF1)**

Pin Number	Definition
9	PW_ON
10	Ground

## Reset Connector

The reset connector is located on pins 12 and 13 of JF1. This connector attaches to the hardware reset switch on the computer case. See the table on the right for pin definitions.

**Reset Pin  
Definitions  
(JF1)**

Pin Number	Definition
12	Ground
13	Reset

## IDE LED

The IDE LED is located on pins 1 to 4 of JF2. This connection is used to display hard drive LED activity. See the table on the right for pin definitions.

**IDE LED  
Pin Definitions  
(JF2)**

Pin Number	Definition
1	+5V
2	HD Active
3	HD Active
4	+5V

## Power\_LED Connector

The Power LED connector is located on pins 5-7 of JF2. This connection is used to provide LED indication of power being supplied to the system. See the table on the right for pin definitions.

**Power\_LED  
Pin Definitions (JF2)**

Pin Number	Definition
5	+5V
6	Key
7	Ground

## Keylock Connector

The keylock connector is located on pins 8 and 9 of JF2. See the table on the right for pin definitions.

**Keylock  
Pin Definitions  
(JF2)**

Pin Number	Definition
8	+5V
9	Ground

## Speaker Connector

The speaker connector is located on pins 10 to 13 of JF2. See the table on the right for pin definitions.

**Speaker Pin  
Definitions (JF2)**

Pin Number	Function	Definition
10	+	Red wire, Speaker data
11	Key	No connection
12	Key	No connection
13	-	Speaker data

## Serial Ports

Two connectors, for the COM1 and COM2 serial ports, are provided on your board. See the table on the right for pin definitions.

**Serial Port Pin Definitions  
(COM1, COM2)**

Pin Number	Definition	Pin Number	Definition
1	DCD	6	CTS
2	DSR	7	DTR
3	Serial In	8	RI
4	RTS	9	Ground
5	Serial Out	10	NC

**WHICH IS CORRECT**

Pin Number	Definition	Pin Number	Definition
1	DCD	6	DSR
2	Serial In	7	RTS
3	Serial Out	8	CTS
4	DTR	9	RI
5	Ground	10	NC*

(Note: NC indicates no connection.)

## CD Headers

There are two CD headers of different sizes on the motherboard for audio CD playback. You must connect an audio cable from your CD player to the header that fits your cable's connector. Only one CD header can be used at any one time. See the tables on the right for pin definitions.

**Audio CD Header Pin Definitions (CD1)**

Pin Number	Definition
1	Left Stereo Signal
2	Ground
3	Ground
4	Right Stereo Signal

**Audio CD Header Pin Definitions (CD2)**

Pin Number	Definition
1	Right Stereo Signal
2	Ground
3	Left Stereo Signal
4	Ground

## Fan Headers

There are one CPU Fan, two Chassis Fan and one Overheat Fan headers on the motherboard. See the table on the right for pin definitions.

**Fan Header Pin Definitions (CPU, Chassis and Overheat)**

Pin Number	Definition
1	Ground (black)
2	+12V (red)
3	Tachometer

Caution: These fan headers are DC power.

## Chassis Intrusion

The Chassis Intrusion header is located on JL1. See the board layouts in Chapter 1 for its location. See the table on the right for pin definitions.

**Chassis Intrusion Pin Definitions (JL1)**

Pin Number	Definition
1	Intrusion Input
2	Ground

## Overheat LED (JOH1)

Connect an LED to the JOH1 header to provide warning of chassis overheating. See the table on the right for pin definitions.

**Overheat LED Pin Definitions (JOH1)**

Pin Number	Definition
1	12VDC
2	OH Active

## ATX PS/2 Keyboard and PS/2 Mouse Ports

The ATX PS/2 keyboard and the PS/2 mouse are located on J17. See the table on the right for pin definitions. (The mouse port is above the keyboard port. See the table on the right for pin definitions.

**PS/2 Keyboard and Mouse Port Pin Definitions (J17)**

Pin Number	Definition
1	Data
2	NC
3	Ground
4	VCC
5	Clock
6	NC

## Universal Serial Bus (USB)

Two Universal Serial Bus connectors (USB0 and USB1) are located on J18 and J19. See the table on the right (above) for pin definitions. The P4SDA+/P4SDM also provides two additional USB headers on the motherboard, which provide easy front side chassis access (cables are not included). See the tables on the right (below) for pin definitions.

**USB0/USB1 Port Pin Definitions (J18/J19)**

Pin#	Definition
1	+5V
2	PO-
3	PO+
4	Ground

**USB2**

Pin Number	Definition
1	+5V
2	PO-
3	PO+
4	Ground
5	Ground

**USB3**

Pin Number	Definition
1	+5V
2	PO-
3	PO+
4	Ground
5	Key

## Wake-On-LAN

The Wake-On-LAN header is located on WOL. See the table on the right for pin definitions. You must enable the LAN Wake-Up setting in BIOS to use this function. (You must also have a LAN card with a Wake-on-LAN connector and cable to use this feature.)

**Wake-On-LAN Pin Definitions (WOL)**

Pin Number	Definition
1	+5V Standby
2	Ground
3	Wake-up

## Wake-On-Ring

The Wake-On-Ring header is designated as JWOR on the P4SDA+. This function allows your computer to receive and be "awakened" by an incoming call when in the suspend state. See the table on the right for pin definitions. You must also have a WOR card and cable to use WOR.

**Wake-On-Ring Pin Definitions  
(JWOR1)**

Pin Number	Definition
1	Ground
2	Wake-up

## 2-7 Jumper Settings

### Explanation of Jumpers

To modify the operation of the motherboard, jumpers can be used to choose between optional settings. Jumpers create shorts between two pins to change the function of the connector. Pin 1 is identified with a square solder pad on the printed circuit board. See the motherboard layout pages for jumper locations.

**Note:** On a two-pin jumper, "Closed" means the jumper is on both pins and "Open" means the jumper is either on only one pin or completely off.

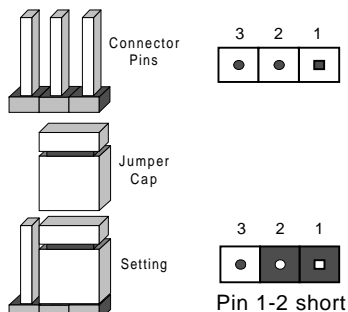

### CMOS Clear

Refer to the table on the right for instructions on how to clear CMOS. Always remove the AC power cord from the system before clearing CMOS.

**Note:** For an ATX power supply, you must completely shut down the system, remove the AC power cord, then use JBT1 to clear CMOS. Replace JBT1 back to the pin 1-2 position before powering up the system again. Do not use the PW\_ON connector to clear CMOS.

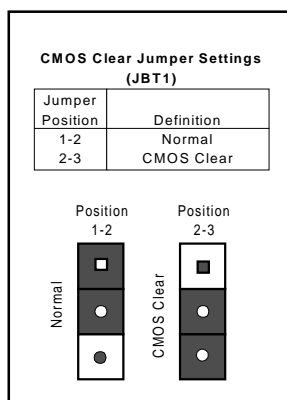

## AC'97

AC'97 brings high quality audio to PCs. When enabled with JP4, audio is processed onboard and the CNR slot will support modems only. The disabled setting should be selected when you wish to use an add-on card for audio either in the CNR or a PCI slot. See the table on the right for pin definitions.

**AC97 Enable/Disable  
Jumper Settings (JP4)**

Jumper Position	Definition
1-2	Enabled
2-3	Disabled

## USB Wake-Up

This jumper is used to enable or disable the USB Wake-Up function. This function allows you to wakeup the system by depressing a key on the keyboard or clicking the mouse when either is connected to a USB port. This jumper is used together with the USB Wake-Up function in BIOS. Enable both the jumper and the BIOS setting to allow the system to be awakened up by depressing a key on the keyboard. See the table on the right for pin definitions.

**USB Wake-Up  
Jumper Settings (JP37)**

Jumper Position	Definition
1-2	Disabled
2-3	Enabled

## Watch Dog Enable

This jumper is used to enable or disable the Watch Dog function. This jumper is used together with the Watch Dog enable function in BIOS. Enable both the jumper and the BIOS setting to use the Watch Dog feature. See the table on the right for pin definitions.

**Watch Dog Enable  
Jumper Settings (JP39)**

Jumper Position	Definition
Open	Disabled
Closed	Enabled

## Keyboard Wake-Up

The JPWAKE jumper is used together with the Keyboard Wake-Up function in BIOS. Enable both the jumper and the BIOS setting to allow the system to be awakened up by depressing a key on the keyboard. See the table on the right for pin definitions. Your power supply must meet ATX specification 2.01 or higher and supply 720 mA of standby power to use this feature.

Keyboard Wake-Up  
Jumper Settings  
(JPWAKE)

Jumper Position	Definition
1-2	Disabled
2-3	Enabled

## 2-8 Game Port, Parallel Port, Floppy Drive, Hard Drive and AGP Connections

Use the following information to connect the floppy and hard disk drive cables.

- The floppy disk drive cable has seven twisted wires.
- A red mark on a wire typically designates the location of pin 1.
- A single floppy disk drive ribbon cable has 34 wires and two connectors to provide for two floppy disk drives. The connector with twisted wires always connects to drive A, and the connector that does not have twisted wires always connects to drive B.
- The 80-wire ATA100/66 IDE hard disk drive cable that came with your system has two connectors to support two drives. This special cable should be used to take advantage of the speed this new technology offers. The blue connector connects to the onboard IDE connector interface and the other connector(s) to your hard drive(s). Consult the documentation that came with your disk drive for details on actual jumper locations and settings for the hard disk drive.

**Game Port Pin Definitions  
(GAME PORT)**

Pin Number	Function	Pin Number	Function
1	+5V fused	2	GP4 (JSBUTO)
3	GP0 (JSX1R)	4	Ground
5	Ground	6	GP1 (JSY1R)
7	GP5 (JSBUT1)	8	+5V fused
9	+5V fused	10	GP6 (JSBUT2)
11	GP2 (JSX2R)	12	MIDI-OUTR
13	GP3 (JSY2R)	14	GP7 (JSBUT3)
15	MIDI-INR		

## Game Port Connector

The game port is the gold port on the I/O backplane. See the table on the left for pin definitions.

**Parallel (Printer) Port Pin Definitions  
(J22)**

Pin Number	Function	Pin Number	Function
1	Strobe-	2	Auto Feed-
3	Data Bit 0	4	Error-
5	Data Bit 1	6	Init-
7	Data Bit 2	8	SLCT IN-
9	Data Bit 3	10	GND
11	Data Bit 4	12	GND
13	Data Bit 5	14	GND
15	Data Bit 6	16	GND
17	Data Bit 7	18	GND
19	ACK	20	GND
21	BUSY	22	GND
23	PE	24	GND
25	SLCT	26	NC

## Parallel Port Connector

The parallel port is located on J22. See the table on the left for pin definitions.

## Floppy Connector

The floppy connector is located on JP5. See the table on the right for pin definitions.

**Floppy Connector Pin Definitions (JP5)**

Pin Number	Function	Pin Number	Function
1	GND	2	FDHDIN
3	GND	4	Reserved
5	Key	6	FDDEDIN
7	GND	8	Index-
9	GND	10	Motor Enable
11	GND	12	Drive Select B-
13	GND	14	Drive Select A-
15	GND	16	Motor Enable
17	GND	18	DIR-
19	GND	20	STEP-
21	GND	22	Write Data-
23	GND	24	Write Gate-
25	GND	26	Track 00-
27	GND	28	Write Protect-
29	GND	30	Read Data-
31	GND	32	Side 1 Select-
33	GND	34	Diskette

**IDE Connector Pin Definitions  
(J6, J7)**

Pin Number	Function	Pin Number	Function
1	Reset IDE	2	GND
3	Host Data 7	4	Host Data 8
5	Host Data 6	6	Host Data 9
7	Host Data 5	8	Host Data 10
9	Host Data 4	10	Host Data 11
11	Host Data 3	12	Host Data 12
13	Host Data 2	14	Host Data 13
15	Host Data 1	16	Host Data 14
17	Host Data 0	18	Host Data 15
19	GND	20	Key
21	DRQ3	22	GND
23	I/O Write-	24	GND
25	I/O Read-	26	GND
27	IOCHRDY	28	BALE
29	DACK3-	30	GND
31	IRQ14	32	IOCS16-
33	Addr 1	34	GND
35	Addr 0	36	Addr 2
37	Chip Select 0	38	Chip Select 1-
39	Activity	40	GND

## IDE Connectors

There are no jumpers to configure the onboard IDE interfaces J6 and J7. See the table on the left for pin definitions. You must use the ATA100/66 cable included with your system to benefit from the ATA100/66 technology.

## AGP Pro/4xAGP Slot (1.5V only)

The AGP Pro slot is backward compatible with AGP Pro and 4xAGP graphics cards, which have fewer pins than AGP Pro cards. Because of this, care must be taken when installing a graphics card into this slot, as doing so incorrectly can damage your motherboard. For AGP Pro cards, you should remove the orange sticker covering one end of the slot. For other cards, leave this sticker in place and make sure your card does not plug into the section it covers. A general rule of thumb is to make sure your card fills the center section of pins first, then the end toward the edge of the motherboard if there are more. If the I/O shield of your card is flush with the edge of the motherboard, the card should be inserted correctly.



## 2-9 Installing Software Drivers

After all the hardware has been installed, you must install, first of all, the operating system, and then, the software drivers. The necessary drivers are all included on the Supermicro CD that came packaged with your motherboard. After inserting this CD into your CDROM drive, the display shown in Figure 2-5 should appear. (If this display does not appear, click on the My Computer icon and then on the icon representing your CDROM drive. Finally, double click on the S "Setup" icon.)

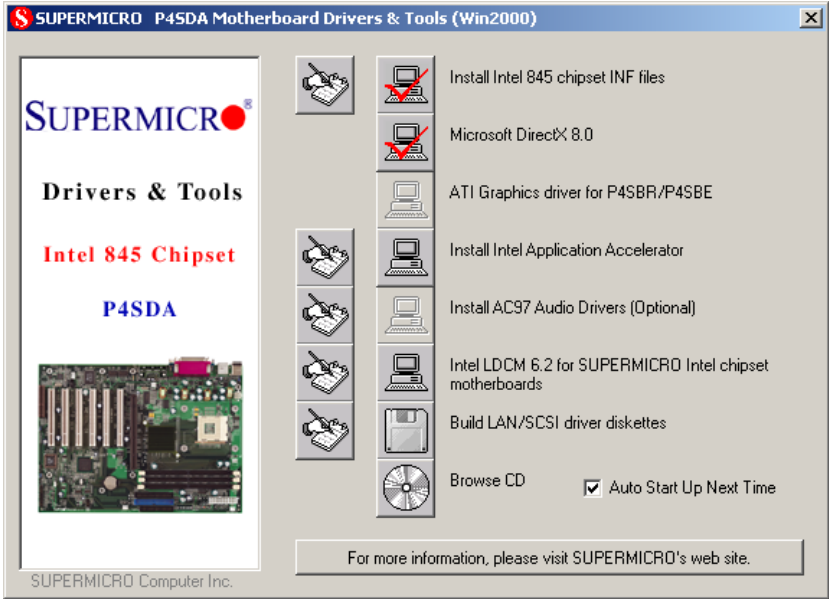

**Figure 2-5. Driver/Tool Installation Display Screen**

Click the icons showing a hand writing on paper to view the readme files for each item. Click the tabs to the right of these *in order from top to bottom* to install each item one at a time. **After installing each item, you must reboot the system before moving on to the next item on the list.** You should install everything here except for the SUPER Doctor utility, which is optional. The Security and Graphics Drivers support multiple languages. Click the arrows to pull down a menu of choices. The bottom icon with a CD on it allows you to view the entire contents of the CD.

**Note:** The memory size reported in the device manager may be less than expected because some is used by the onboard graphics. Higher screen resolutions will take up more of this memory.

**Notes**

## Chapter 3

# Troubleshooting

### 3-1 Troubleshooting Procedures

Use the following procedures to troubleshoot your system. If you have followed all of the procedures below and still need assistance, refer to the 'Technical Support Procedures' and/or 'Returning Merchandise for Service' section(s) in this chapter. **Note: Always disconnect the power cord before adding, changing or installing any hardware components.**

#### Before Power On

1. Make sure no short circuits exist between the motherboard and chassis.
2. Disconnect all ribbon/wire cables from the motherboard, including those for the keyboard and mouse.
3. Remove all add-on cards.
4. Install a CPU (making sure it is fully seated) and connect the chassis speaker and the power LED to the motherboard. (Check all jumper settings as well.)

#### No Power

1. Make sure no short circuits exist between the motherboard and the chassis.
2. Verify that all jumpers are set to their default positions.
3. Check that the 115V/230V switch on the power supply is properly set.
4. Turn the power switch on and off to test the system.
5. The battery on your motherboard may be old. Check to verify that it still supplies ~3VDC. If it does not, replace it with a new one.

#### No Video

1. If the power is on but you have no video, remove all the add-on cards and cables.
2. Use the speaker to determine if any beep codes exist. Refer to Appendix A for details on beep codes.

---

**NOTE**

If you are a system integrator, VAR or OEM, a POST diagnostics card is recommended. For I/O port 80h codes, refer to App. B.

---

### **Memory Errors**

1. Make sure the DIMM modules are properly and fully installed.
2. Determine if different speeds of DIMMs have been installed and verify that the BIOS setup is configured for the fastest speed of memory used. It is recommended to use the same memory speed for all DIMMs in the system. See Section 2-4 for memory limitations.
3. Check for bad DIMM modules or slots by swapping modules between slots and noting the results.
4. Check the power supply voltage 115V/230V switch.

### **Losing the System's Setup Configuration**

1. Check the setting of jumper JBT1. Ensure that you are using a high quality power supply. A poor quality power supply may cause the system to lose the CMOS setup information. Refer to Section 1-6 for details on recommended power supplies.
2. The battery on your motherboard may be old. Check to verify that it still supplies ~3VDC. If it does not, replace it with a new one.
3. If the above steps do not fix the Setup Configuration problem, contact your vendor for repairs.

## **3-2 Technical Support Procedures**

Before contacting Technical Support, please take the following steps. Also, note that as a motherboard manufacturer, Supermicro does not sell directly to end-users, so it is best to first check with your distributor or reseller for troubleshooting services. They should know of any possible problem(s) with the specific system configuration that was sold to you.

1. Please go through the 'Troubleshooting Procedures' and 'Frequently Asked Questions' (FAQs) sections in this chapter or see the FAQs on our web site (<http://www.supermicro.com/techsupport.htm>) before contacting

Technical Support.

2. BIOS upgrades can be downloaded from our web site at <http://www.supermicro.com/techsupport/download.htm>.

**Note: Not all BIOS can be flashed depending on the modifications to the boot block code.**

3. If you still cannot resolve the problem, include the following information when contacting Supermicro for technical support:
  - Motherboard model and PCB revision number
  - BIOS release date/version (this can be seen on the initial display when your system first boots up)
  - System configuration

An example of a Technical Support form is on our web site at [http://www.supermicro.com/techsupport/contact\\_support.htm](http://www.supermicro.com/techsupport/contact_support.htm).

4. Distributors: For immediate assistance, please have your account number ready when placing a call to our technical support department. We can be reached by e-mail at [support@supermicro.com](mailto:support@supermicro.com) or by fax at (408) 503-8019.

### 3-3 Frequently Asked Questions

**Question: What are the various types of memory that the P4SDA+/P4SDM motherboard can support?**

**Answer:** The P4SDA+/P4SDM has three 184-pin DDR (double data rate) DIMM slots that support up to 2 GB of PC1600 and PC2100 DDR SDRAM. ECC memory and Parity Checking are supported. **Important:** See Section 2-4 on rules to observe when installing DDR memory modules.

**Question: How do I update my BIOS?**

**Answer:** It is recommended that you not upgrade your BIOS if you are not experiencing problems with your system. Updated BIOS files are located on our web site at <http://www.supermicro.com>. Please check our BIOS warning message and the information on how to update your BIOS on our web site. Also, check the current BIOS revision and make sure it is newer than your current BIOS before downloading. Select your mainboard model and download the BIOS file to your computer. Unzip the BIOS update file and you will find the readme.txt (flash instructions), the awdf flash.exe (BIOS flash utility) and the BIOS image (xxxx.bin) files. Copy these files onto a bootable floppy and reboot your system. It is not necessary to set the BIOS

boot block protection jumpers on the mainboard. At the DOS prompt upon rebooting, enter the command "awdf flash." Then type in the BIOS file that you want to update (xxxx.bin).

**Question: After flashing the BIOS my system does not have video. How can I correct this?**

**Answer:** If the system does not have video after flashing your new BIOS, it indicates that the flashing procedure failed. To remedy this, first clear CMOS per the instructions in this manual and retry the BIOS flashing procedure. If you still do not have video, please use the following **BIOS Recovery Procedure**. First, make sure the JPWAKE jumper is disabled. Then, turn your system off and place the floppy disk with the saved BIOS image file (see above FAQ) in drive A. Press and hold <Alt> and <F2> at the same time, then turn on the power keeping these keys pressed until your floppy drive starts reading. Your screen will remain blank until the BIOS program is done. If the system reboots correctly, then the recovery was successful. The BIOS Recovery Procedure will not update the boot block in your BIOS.

**Question: What's in the CD that came with my motherboard?**

**Answer:** The supplied compact disc has quite a few drivers and programs that will greatly enhance your system. We recommend that you review the CD and install the applications you need. Applications on the CD include 850 chipset drivers for Windows and security and audio drivers.

**Question: Why can't I turn off the power using the momentary power on/off switch?**

**Answer:** The instant power off function is controlled in BIOS by the Power Button Mode setting. When the On/Off feature is enabled, the motherboard will have instant off capabilities as long as the BIOS has control of the system. When the Standby or Suspend feature is enabled or when the BIOS is not in control such as during memory count (the first screen that appears when the system is turned on), the momentary on/off switch must be held for more than four seconds to shut down the system. This feature is required to implement the ACPI features on the motherboard.

**Question:** I see some of my PCI devices sharing IRQs, but the system seems to be fine. Is this correct or not?

**Answer:** Some PCI Bus Mastering devices can share IRQs without performance penalties. These devices are designed to work correctly while sharing IRQs. See Table 3-1, below, for details on shared IRQs.

**Table 3-1. P4SDA+/P4SDM Shared IRQs**

PCI 1 shares an IRQ with AC97, CNR and the System Management bus
PCI 2 has a dedicated IRQ (does not share)
PCI 3 shares an IRQ with USB controller #1 (USB0 & USB1)
PCI 4 has a dedicated IRQ (does not share)*
PCI 5 has a dedicated IRQ (does not share)*
PCI 6 shares an IRQ with USB controller #2 (USB2 & USB3)*

\*PCI 4-6 do NOT apply to P4SDM

**Question:** I installed my microphone correctly but I can't record any sound. What should I do?

**Answer:** Go to <Start>, <Programs>, <Accessories>, <Entertainment> and then <Volume Control>. Under the Properties tab, scroll down the list of devices in the menu and check the box beside "Microphone".

**Question:** How do I connect the ATA100/66 cable to my IDE device(s)?

**Answer:** The 80-wire/40-pin high-density ATA100/66 IDE cable that came with your system has two connectors to support two drives. This special cable must be used to take advantage of the speed the ATA100/66 technology offers. **Connect the blue connector to the onboard IDE header and the other connector(s) to your hard drive(s).** Consult the documentation that came with your disk drive for details on actual jumper locations and settings.

### **3-4 Returning Merchandise for Service**

A receipt or copy of your invoice marked with the date of purchase is required before any warranty service will be rendered. You can obtain service by calling your vendor for a Returned Merchandise Authorization (RMA) number. When returning to the manufacturer, the RMA number should be prominently displayed on the outside of the shipping carton, and mailed prepaid or hand-carried. Shipping and handling charges will be applied for all orders that must be mailed when service is complete.

This warranty only covers normal consumer use and does not cover damages incurred in shipping or from failure due to the alteration, misuse, abuse or improper maintenance of products.

During the warranty period, contact your distributor first for any product problems.

# Chapter 4

## AwardBIOS

### 4-1 Introduction

This chapter describes the AwardBIOS for the P4SDA+/P4SDM. The Award ROM BIOS is stored in a Flash chip and can be easily upgraded using a floppy disk-based program.

**Note:** Due to periodic changes to the BIOS, some settings may have been added or deleted and might not yet be recorded in this manual. Refer to the Manual Download area of our web site for any changes to BIOS that are not reflected in this manual.

#### System BIOS

The BIOS is the Basic Input Output System used in all IBM® PC, XT™, AT®, and PS/2® compatible computers. The AwardBIOS Flash chip stores the system parameters, such as amount of memory, type of disk drives and video displays, etc. CMOS requires very little power. When the computer is turned off, a back-up battery provides power to the BIOS Flash chip, enabling it to retain the system parameters. Each time the computer is powered-on, the computer is then configured with the values stored in the BIOS ROM by the system BIOS, which gains control when the computer is powered on.

#### How To Change the Configuration Data

The CMOS information that determines the system parameters may be changed by entering the BIOS Setup utility. This Setup utility can be accessed by pressing <Del> at the appropriate time during system boot.

#### Starting the Setup Utility

Normally, the only visible POST (Power On Self Test) routine is the memory test. As the memory is being tested, press the <Delete> key to enter the main menu of the BIOS Setup utility. From the main menu, you can access the other setup screens, such as the Chipset and Power menus. Section 4-3 gives detailed descriptions of each parameter setting in the Setup utility.

## 4-2 Running Setup

*\*Optimal default settings are in bold text unless otherwise noted.*

The BIOS setup options described in this section are selected by choosing the appropriate text from the Main BIOS Setup screen. All displayed text is described in this section, although the screen display is often all you need to understand how to set the options (see on next page).

When you first power on the computer, the AwardBIOS™ is immediately activated.

While the BIOS is in control, the Setup program can be activated in one of two ways:

1. By pressing <Del> immediately after turning the system on, or
2. When the following message appears briefly at the bottom of the screen during the POST (Power On Self-Test), press the <Del> key to activate the Main Setup Menu.

**Press DEL to enter SETUP**

## 4-3 Main BIOS Setup

All Main Setup options are described in this section. The Main BIOS Setup screen is displayed below.

Use the <Up> <Down> arrow keys or the <Tab> key to move among the different settings in the above menu.

Press the <Esc> key to exit the CMOS Setup Menu and use the <Left> <Right> arrow keys to enter the the other categories of BIOS settings. The next section is described in detail to illustrate how to navigate through the menus.

## Main BIOS Setup Menu

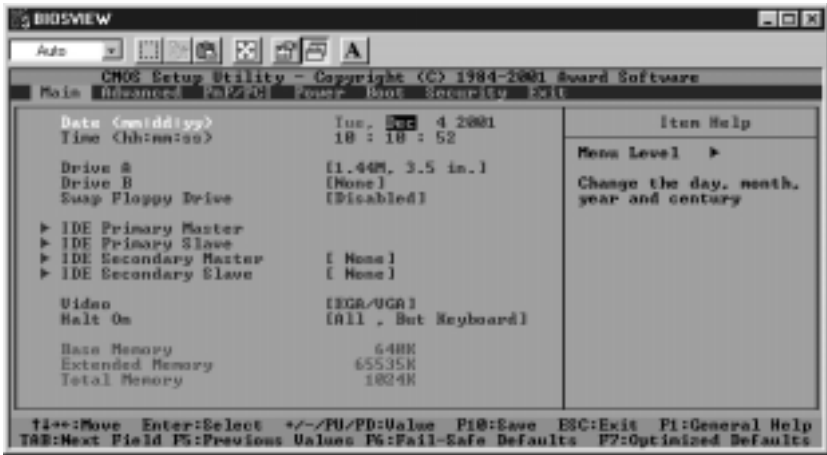

### Date/Time

Set the system date and time. Key in the correct information in the "mm", "dd" and "yy" fields. Press the "Enter" key to save the data.

### Drive A/Drive B

These settings allow the user to set the type of floppy disk drive installed in the system. The options are "None", "360K, 5.25 in", "1.2M, 5.25 in", "720K, 3.5 in", "1.44M, 3.5 in" and "2.88M, 3.5 in". Default settings are "1.44, 3.5" in for Drive A and "None" for Drive B.

### Swap Floppy Drive

This setting allows the user to swap the designation (A and B) of the floppy disk drives installed in the system (if there are two floppy disk drives installed on the mainboard). The options are "**Disabled**" and "Enabled".

### IDE Primary Master/IDE Primary Slave/IDE Secondary Master/IDE Secondary Slave

These options allow the user to set the parameters of the IDE Primary Master/Slave and IDE Secondary Master/Slave slots. Press "Enter" to activate the following sub-menu screen for detailed options of these items. Set the correct configurations accordingly. The items included in the sub-menu are listed below:

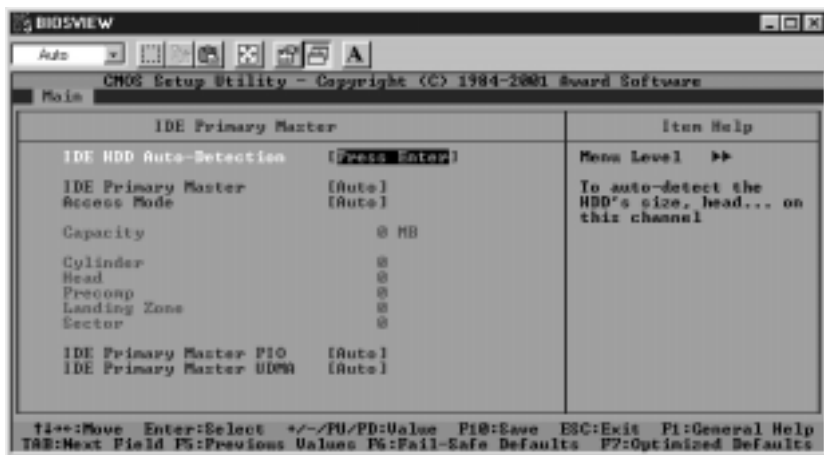

## IDE HDD Auto-Detection

Press the <Enter> key to activate the "IDE HDD Auto-Detection" function, which will allow BIOS to automatically detect the status of the IDE HDD installed in the system, such as the size and number of cylinders.

## IDE Primary Master

This option allows the user to determine the manner in which the AwardBIOS sets the settings for the IDE Primary Master Device. The options are "None", "**Auto**" and "Manual."

## Access Mode

This item determines the location through which the AwardBIOS accesses the IDE Primary Master Device. The settings are "CHS", "LBA", "Large", and "**Auto**".

## IDE Primary Slave PIO

See the previous setting for description. The options for this setting are "**Auto**", "Mode 0", "Mode 1", "Mode 2", "Mode 3" and "Mode 4".

## IDE Primary Master UDMA

This is available only when your IDE drive supports UDMA and the operating environment also includes a UDMA drive. If your IDE hard drive and your system software both support UDMA, select Auto to enabled BIOS support. The options for this setting are "**Auto**" and "Disabled".

## Video

Use this setting to specify the type of display you are using with the system. Options are "**EGA/VGA**", "CGA 40", "CGA 80" and "MONO".

## Halt On

If the system encounters a non-specified error during boot-up, it will come to a halt as directed by these settings. You can tell the system to halt on "All Errors", "No Errors", "**All, But Keyboard**", "All, But Diskette" or "All, But Disk/Key".

## Base Memory/Extended Memory/Total Memory

These are displays that inform you how much of each type of memory is recognized as being present in the system.

## 4-4 Advanced BIOS Setup

Choose Advanced BIOS Setup from the Award BIOS main menu with the Left/ Right arrow keys. You should see the following display. Select one of the items in the left frame of the screen to go to the sub screen for that item. Advanced BIOS Setup options are displayed by highlighting the option using the arrow keys. All Advanced BIOS Setup options are described in this section.

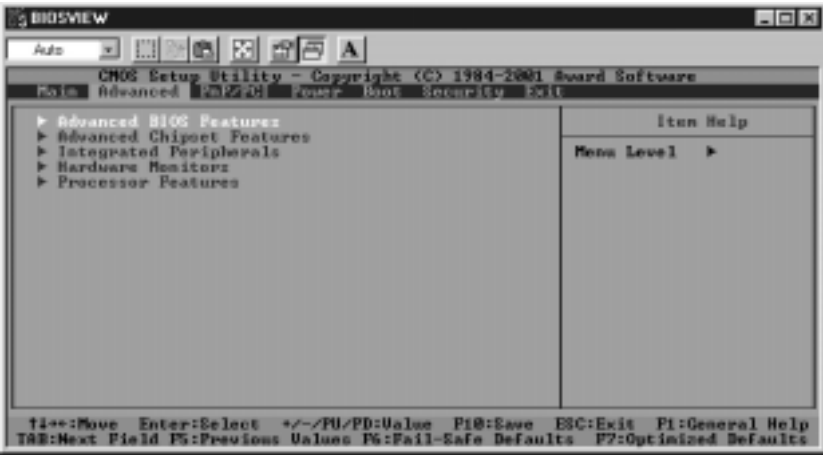

### 4-4.1 Advanced BIOS Features

When the item of Advanced BIOS Features is highlighted, press the <Enter> key to activate the screen below:

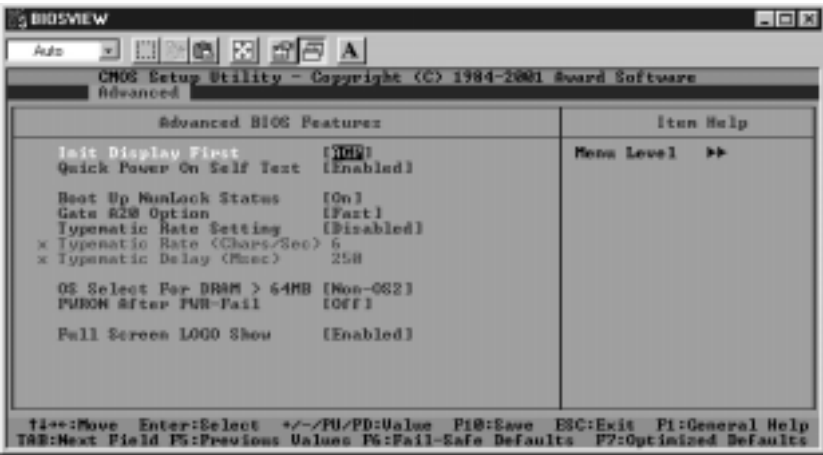

## **Init Display First**

This setting allows the user to determine which device will be first displayed when the system boots up - a device installed in the PCI slot or a device installed in the AGP slot. The options are "PCI slot" and "**AGP**".

## **Quick Power-On Self Test**

If enabled, this feature will speed up the POST (Power On Self Test) routine after the computer is switched on. The settings are "**Enabled**" and "Disabled". If "Disabled", the POST will run at normal speed.

## **Boot Up NumLock Status**

This option enables the system to check the status of the NumLock key during boot-up. The settings are "**On**" and "Off".

## **Gate A20 Option**

This option allows the user to determine if the chipset or the keyboard controller should have the control over Gate A20. The settings are "Normal" or "Fast." If set to "Normal", a pin in the keyboard controller controls Gate A20. If "Fast" is selected, the chipset will have the control over Gate A20. The default setting is "Fast."

## **Typematic Rate Setting**

If enabled, the option allows the user to set the number of times a key stroke repeats itself in a second when the key is held down. If disabled, the keyboard controller sets the rate.

### **Typematic Rate (Chars/Sec)**

You may change this setting only if the Typematic Rate Setting is enabled. This setting allows the user to set the number of times a key stroke repeats itself in a second when the key is held down. The options are: "**6**", "8", "10", "12", "15", "20", "24" and "30."

### **Typematic Delay**

You may change this setting only if the Typematic Rate Setting is

---

enabled. This setting sets the delay time after a key is held down before it begins to repeat the keystroke. The settings are: "**250**", "500", "750" and "1000."

### **OS Select For DRAM > 64MB**

This setting should be changed only if using OS2 and your system has more than 64 MB of RAM. The options are "OS2" and "**Non-OS2**".

### **PWRON After PWR-Fail**

This setting allows the user to specify how the system will respond when power is reapplied after the system has gone down due to a power failure. The options are "**Off**", "On" and "Former-Sts".

### **Full Screen Logo Show**

The options for this setting are "**Enabled**" and "Disabled".

## 4-4.2 Advanced Chipset Features

This section covers the functions used for configuring the system based upon the special features offered by the Plumas chipset. The chipset manages the operations of major components of the board. Normally, the default settings for the Advanced Chipset Features listed in the section are pre-configured by the manufacturer for the optimal performance of the system. It is recommended that the user does not alter the default settings. This section is provided as an emergency measure for the user to restore the functions of the system when the critical data stored in the BIOS is lost.

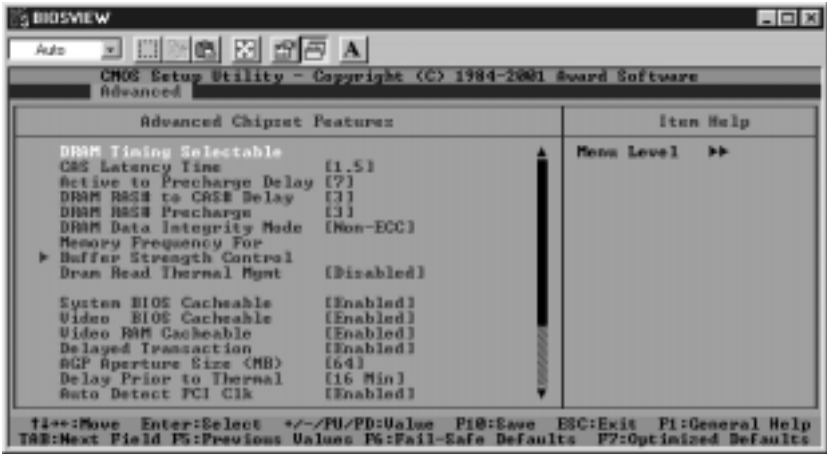

### DRAM Timing Selectable

This item regulates dynamic random access memory (DRAM) timing. The options are "Manual" and "By SPD".

### CAS Latency Time

This item regulates memory column address strobe (CAS) timing. The settings are "1.5", "2", "2.5" and "3".

### **Active to Precharge Delay**

This item regulates the number of memory clock cycles allowed for memory refresh charging. The options are "7", "6" and "5". Shorter timings increase system memory throughput at the risk of lacking sufficient refresh charge.

### **DRAM RAS# to CAS# Delay**

This item regulates the number of memory clock cycles between strobing a row address (RAS) and a column address (CAS). Shorter numbers of clock cycles improve system memory performance at the risk of missing data. The options are "3" and "2".

### **DRAM RAS Precharge**

This item regulates the number of system memory clock cycles for RAS precharging. The options are "3" and "2".

### **DRAM Data Integrity Mode**

This item regulates CPU access to the data stored in the protected area of dynamic random access memory (DRAM) on the motherboard. To preserve its integrity, critical system information is usually stored in a protected area of memory. If set to the "ECC" mode, the CPU will have access to data stored in the area when performing ECC (Error Correction/Checking) activities. The options are "ECC" and "**Non-ECC**".

### **Memory Frequency For**

This item regulates system memory frequency. The options are "PC100", "PC133" and "**Auto**".

### **Buffer Strength Control**

Highlight this field and press <Enter> to bring up the following settings relating to buffer strength control. It is recommended that you do not make changes to these settings.

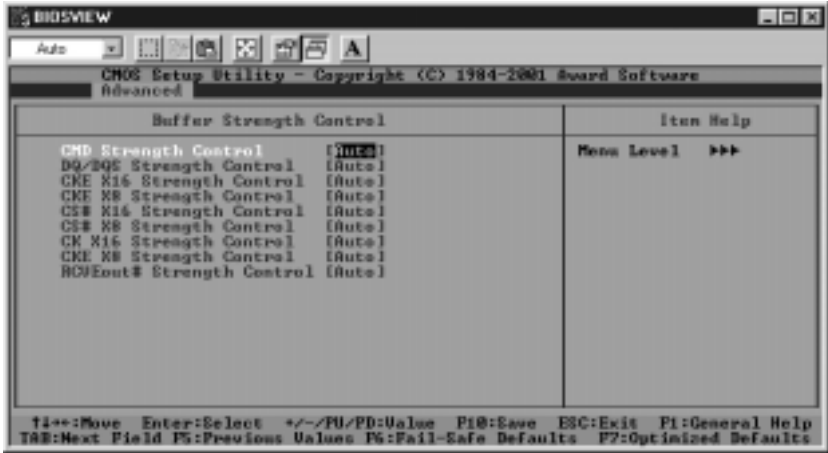

### CMD Strength Control

The options for this setting are **Auto**, "0.75 X", "1.00 X", "1.25 X", "1.50 X", "2.00 X", "2.50 X", "3.00 X" and "4.00 X".

### DQ/DQS Strength Control

The options for this setting are **Auto**, "0.75 X", "1.00 X", "1.25 X", "1.50 X", "2.00 X", "2.50 X", "3.00 X" and "4.00 X".

### CKE X16 Strength Control

The options for this setting are **Auto**, "0.75 X", "1.00 X", "1.25 X", "1.50 X", "2.00 X", "2.50 X", "3.00 X" and "4.00 X".

### CKE X8 Strength Control

The options for this setting are **Auto**, "0.75 X", "1.00 X", "1.25 X", "1.50 X", "2.00 X", "2.50 X", "3.00 X" and "4.00 X".

### CS# X16 Strength Control

The options for this setting are **Auto**, "0.75 X", "1.00 X", "1.25 X", "1.50 X", "2.00 X", "2.50 X", "3.00 X" and "4.00 X".

### **CS# X8 Strength Control**

The options for this setting are "**Auto**", "0.75 X", "1.00 X", "1.25 X", "1.50 X", "2.00 X", "2.50 X", "3.00 X" and "4.00 X".

### **CK X16 Strength Control**

The options for this setting are "**Auto**", "0.75 X", "1.00 X", "1.25 X", "1.50 X", "2.00 X", "2.50 X", "3.00 X" and "4.00 X".

### **CKE X8 Strength Control**

The options for this setting are "**Auto**", "0.75 X", "1.00 X", "1.25 X", "1.50 X", "2.00 X", "2.50 X", "3.00 X" and "4.00 X".

### **RCVEout# Strength Control**

The options for this setting are "**Auto**", "0.75 X", "1.00 X", "1.25 X", "1.50 X", "2.00 X", "2.50 X", "3.00 X" and "4.00 X".

## **DRAM Read Thermal Management**

This item regulates the system's ability to read system thermal data. The options are "**Disabled**" and "Enabled".

## **System BIOS Cacheable**

If enabled, the system BIOS information stored in the BIOS ROM (Read Only Memory) chip will be written and temporarily stored in the "cacheable" memory section of the CPU, giving the CPU faster access to the information. The options are "Disabled" and "**Enabled**".

## **Video BIOS Cacheable**

If enabled, the information regarding the Video BIOS stored in the BIOS ROM (Read Only Memory) chip will be written and temporarily stored in the "cacheable" memory section of the CPU, giving the CPU faster access to the information. The options are "Disabled" and "**Enabled**".

### **Video RAM Cacheable**

If enabled, the information regarding the Video card stored in the RAM chip (Random Access Memory) will be written and temporarily stored in the "cacheable" memory section of the CPU, giving the CPU faster access to the information. The options are "Disabled" and "**Enabled**".

### **Delayed Transaction**

This setting compensates for the slower speed of ISA cards on a PCI interface and so is only relevant if ISA cards are present on the motherboard. The options are "**Enabled**" and "Disabled".

### **AGP Aperture size (MB)**

This setting allows the user to set the aperture size for the Accelerated Graphics Port (AGP). The options are "4M", "8M", "16M", "32M", "**64M**", "128M" and "256M".

### **Delay Prior to Thermal**

The options for this setting are "4 Min", "8 Min", "**16 Min**" and "32 Min".

### **Auto Detect PCI Clk**

This setting allows the PCI clock rate to be automatically determined. The options for this setting are "**Enabled**" and "Disabled".

### **On-Chip Primary PCI IDE**

The integrated peripheral controller contains an IDE interface with support for two IDE channels. Select Enabled to activate each channel separately. The options for this setting are "**Enabled**" and "Disabled".

### **On-Chip Secondary PCI IDE**

The integrated peripheral controller contains an IDE interface with support for two IDE channels. Select Enabled to activate each channel separately. The options for this setting are "**Enabled**" and "Disabled".

## USB Controller

You should Enable this setting if your system contains a Universal Serial Bus (USB) controller (it does) and you have USB peripherals. The options for this setting are "**Enabled**" and "Disabled".

## USB Keyboard Support

If enabled, this setting allows the user to activate the BIOS support of the On-Chip USB Keyboard Controller. The options are "**Disabled**" and "Enabled".

## AC 97 Audio

This setting allows the user to activate BIOS support for AC'97 audio. The options for this setting are "**Auto**" and "Disabled".

## AC 97 Modem

This setting allows the user to activate BIOS support for the AC'97 modem. The options for this setting are "**Auto**" and "Disabled". (Requires the use of a CNR add-on card.)

## 4-4.3 Integrated Peripherals

When the item "Integrated Peripherals" is highlighted, press the <Enter> key to activate the following sub-menu screen.

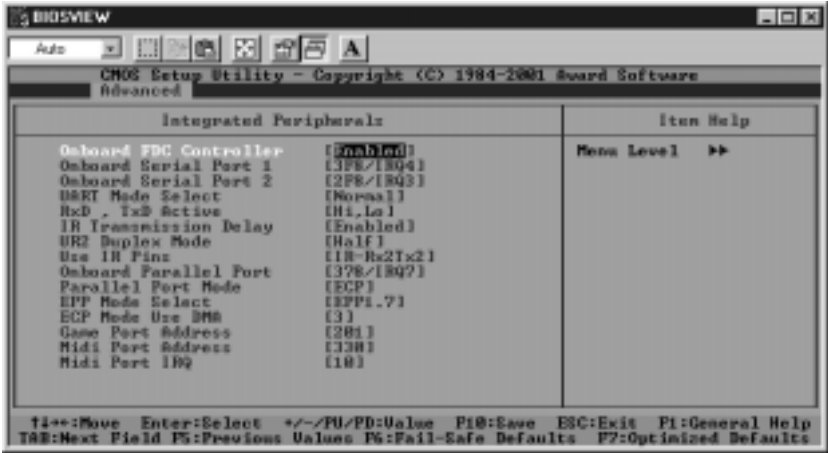

### Onboard FDC Controller

Select "Enabled", if your system has a floppy disk controller (FDC) installed on the main board and you wish to use it. The settings are "Enabled" and "Disabled".

### Onboard Serial Port 1/Port 2

This setting allows the user to set the address and the corresponding IRQ for the Serial Port1 and Serial Port 2. The options are "Disabled", "3F8/IRQ4", "2F8/IRQ3", "3E8/IRQ4", "2E8/IRQ3", and "Auto". The default setting for Serial Port1 is "3F8/IRQ4" and the default for Port 2 is "2F8/IRQ3".

### UART Mode Select

This setting allows the user to select the UART mode for BIOS. The options are "IrDA", "ASKIR" and "Normal".

### **RxD, TxD Active**

This setting allows the user to set the settings for the function of "RxD, TxD Active." The options are "Hi, Hi", "**Hi, Lo**", "Lo, Hi", and "Lo, Lo".

### **IR Transmission Delay**

If "Enabled", the transmission of IR (infrared) signals will be delayed. The options are "**Enabled**" and "Disabled".

### **UR2 Duplex Mode**

This setting set the mode for the UR2 Duplex Mode. The options are "Full" and "**Half**".

### **Use IR Pins**

This item sets the usage of IR pins. The options are "RxD2, TxD2" and "**IR-Rx2Tx2**".

### **Onboard Parallel Port**

This setting allows the user to set the address and the corresponding IRQ for the onboard parallel port. The options are "Disabled", "**378/IRQ7**", "278/IRQ5" and "3BC/IRQ7".

### **Parallel Port Mode**

This setting sets the mode for the onboard Parallel port. The options are "SPP," "EPP", "**ECP**" and "ECP+EPP".

### **EPP Mode Select**

This setting allows the user to select the EPP port type. The options are "EPP 1.9" and "**EPP 1.7**".

### **ECP Mode Use DMA**

This setting allows the user to select the DMA channel for the ECP mode (port) to use. The options are "1" and "**3**".

### **Game Port Address**

This setting allows the user to set the Game Port address. The options are "Disabled", "**201**" and "209."

### **Midi Port Address**

This setting allows the user to set the Midi Port address. The options are "Disabled", "**330**", "300" and "290".

### **Midi Port IRQ**

This setting allows the user to set the Midi Port IRQ. The options are "5" and "**10**".

## 4-4.4 Hardware Monitors

When the item "Hardware Monitors" is highlighted, press the <Enter> key to activate the following sub-menu screen.

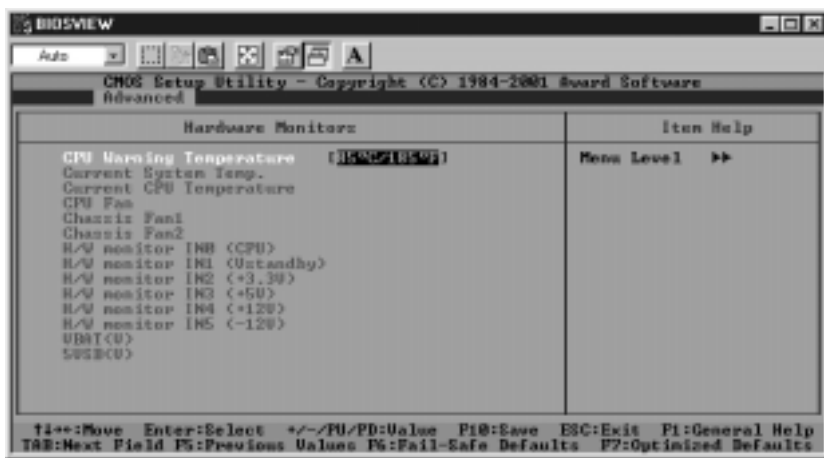

There is only one setting on this menu (below). The rest of this menu shows various temperatures and voltage levels.

### CPU Warning Temperature

This item allows the user to set the CPU temperature threshold. When the CPU temperature reaches the threshold temperature set by the user, the alarm will be set off and a warning message will be displayed on the screen. The options are "Disabled", "50°C/122°F", "60°C/140°F", "65°C/149°F", "70°C/167°F", "75°C/167°F", "80°C/176°F" and **"85°C/185°F"**.

## 4-4.5 Processor Features

When the item "Processor Features" is highlighted, hit the <Enter> key to activate the sub-menu shown below:

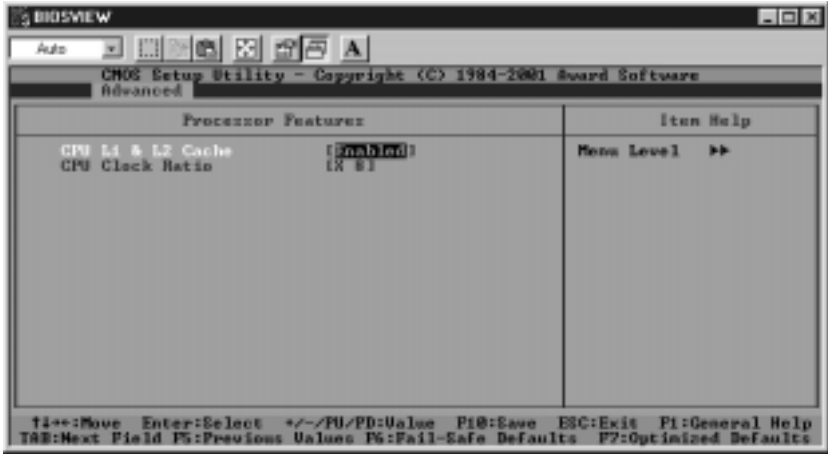

### CPU L1 & L2 Cache

Set this option to "Enable" to activate the function of CPU L1 and L2 cache. The settings are "Disabled", and "**Enabled**".

### CPU Clock Ratio

This item allows the user to change the CPU/Clock ratio. You can key in any whole number between (and including) 8 and 50. The default setting is **8** (meaning x8).

## 4-5 PCI/PnP Configurations

Choose PCI/PnP Configurations from the Award BIOS main menu with the Left/Right arrow keys. You should see the following display:

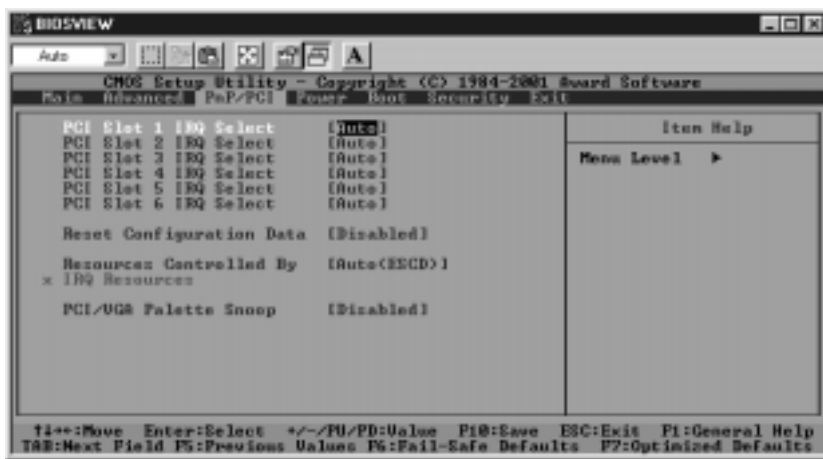

### PCI Slot 1 IRQ Select

Use this setting to select the IRQ (interrupt request) for PCI slot 1. The options are **"Auto"**, "3", "4", "5", "7", "9", "10", "11", "12", "14" and "15".

### PCI Slot 2 IRQ Select

Use this setting to select the IRQ (interrupt request) for PCI slot 2. The options are **"Auto"**, "3", "4", "5", "7", "9", "10", "11", "12", "14" and "15".

### PCI Slot 3 IRQ Select

Use this field setting to select the IRQ (interrupt request) for PCI slot 3. The options are **"Auto"**, "3", "4", "5", "7", "9", "10", "11", "12", "14" and "15".

### PCI Slot 4 IRQ Select

Use this setting to select the IRQ (interrupt request) for PCI slot 4. The options are **"Auto"**, "3", "4", "5", "7", "9", "10", "11", "12", "14" and "15".

### **PCI Slot 5 IRQ Select**

Use this setting to select the IRQ (interrupt request) for PCI slot 5. The options are "Auto", "3", "4", "5", "7", "9", "10", "11", "12", "14" and "15".

### **PCI Slot 6 IRQ Select**

Use this setting to select the IRQ (interrupt request) for PCI slot 6. The options are "Auto", "3", "4", "5", "7", "9", "10", "11", "12", "14" and "15".

### **Reset Configuration Data**

When Enabled, this setting resets the extended system configuration data when you exit setup. Do this when you have installed a new add-on and the system reconfiguration has caused such a serious conflict that the OS cannot reboot the system. The options for this setting are "Enabled" and "Disabled".

### **Resources Controlled By**

This setting allows BIOS to automatically configure all boot and Plug and Play compatible devices. If you choose Auto, you cannot select the IRQ, DMA and memory base address fields, because BIOS automatically assigns them. The options are "Auto <ESCD>" and "Manual".

### **PCI/VGA Palette Snoop**

For best system performance, this item has been pre-set to "Disabled" by the manufacturer. The settings are "Enabled" and "Disabled".

## 4-6 Power

Choose Power from the Award BIOS main menu with the Left/Right arrow keys. You should see the following display:

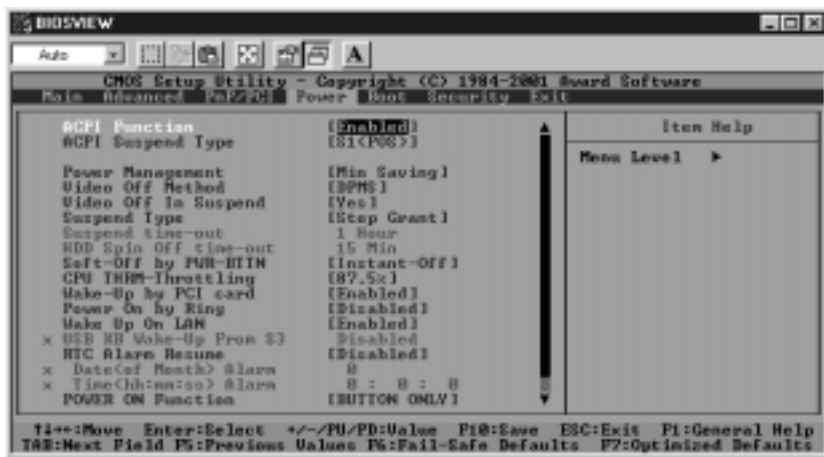

### ACPI Function

This item allows you to enable and disable the ACPI (Advanced Configuration and Power Management) program. The options are "**Enabled**" and "Disabled".

### ACPI Suspend Type

This item allows the user to determine the ACPI Suspend type. The options are "**S1 (POS)**" and "S3 (STR)".

### Power Management

This setting sets the degree of power saving for the system, especially for HDD Power Down, Doze Mode and Suspend Mode. The options are "User Define", "**Min Saving**" and "Max Saving".

### Video Off Method

This item determines the manner in which the monitor is turned off. The options are "Blank Screen", "**V/H SYNC+Blank**" and "DPMS". Select "V/H

SYNC+Blank" to turn off the vertical and horizontal synchronization ports and the monitor. Select "Blank Screen" to turn off the video buffer and the monitor. Select "DPMS" to initiate display power management signals.

### **Video Off in Suspend**

This setting determines whether the display turns off when the system is in the Suspend Mode. The settings are "**Yes**" and "No".

### **Suspend Type**

This item sets the system suspend Mode. The options are "**Stop Grant**" and "PWR On Suspend".

### **Soft-Off by PWR-BTTN**

This item determines the system's "Soft-off" mode when the user presses the power-button. The options for this setting are "**Instant-Off**" and "Delay 4 sec".

### **CPU THRM-Throttling**

THRM throttling is used to lower power consumption and reduce the heat generated by the CPU. The options for this setting are "87.5%", "75%", "62.5%", "**50%**", "37.5%", "25%" and "12.5%".

### **Wake-Up by PCI Card**

If Enabled, the user is able to "wake up" the system via a PCI card. The settings are "Enabled" and "**Disabled**".

### **Power On by Ring**

If Enabled, the user is able to "wake up" the system via the modem. The options for this setting are "**Enabled**" and "Disabled".

### **Wake Up on LAN**

If Enabled, the user is able to "wake up" the system via the LAN. The options for this setting are "**Enabled**" and "Disabled".

### **Resume by Alarm**

If Enabled, this setting will allow the AwardBIOS to turn on the system via the real-time clock (RTC). The options are "Enabled" and "**Disabled**".

### **Date (of Month) Alarm**

Set the date for RTC alarm wake up in this field.

### **Time (hh:mm:s) Alarm**

Set the time for RTC alarm wake up in this field.

### **POWER ON Function**

This setting allows the user to determine the method by which the system power is activated. The options are "Password", "Hot Key", "Mouse Left", "Mouse Right", "Any Key", "**Button Only**" and "Keyboard 98".

### **KB Power On Password**

This setting allows the user to set the password to activate the Power On function through the keyboard. Press <Enter> to enter the password.

### **Hot Key Power On**

This option allows the user to set the hot key to activate the power on function. The settings are "**Ctrl F1**", "Ctrl F2", "Ctrl F3", "Ctrl F4", "Ctrl F5", "Ctrl F6", "Ctrl F7", "Ctrl F8", "Ctrl F9", "Ctrl F10", "Ctrl F11" and "Ctrl F12".

## 4-7 Boot

Choose Boot from the Award BIOS main menu with the Left/Right arrow keys. You should see the following display:

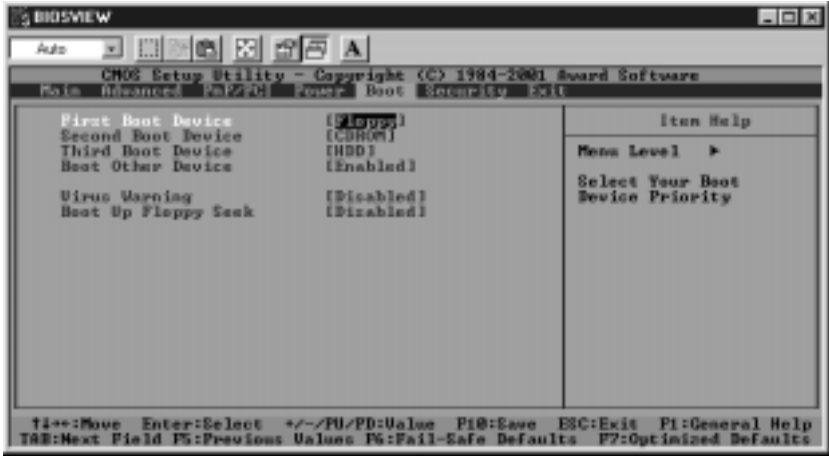

Award BIOS attempts to load the operating system from devices specified by the users in a user-specified sequence.

### First Boot Device

This item allows the user to set the first boot-up device. The options are "Floppy", "LS120", "HDD", "SCSI", "CDROM", "ZIP100", "USB-FDD", "USB-ZIP", "USB-CDROM", "USB-HDD", "LAN" and "Disabled".

### Second Boot Device

This item allows the user to set the second boot-up device. The options are "Floppy", "LS120", "HDD", "SCSI", "CDROM", "ZIP100", "USB-FDD", "USB-ZIP", "USB-CDROM", "USB-HDD", "LAN" and "Disabled".

### Third Boot Device

This item allows the user to set the third boot-up device. The options are "Floppy", "LS120", "HDD", "SCSI", "CDROM", "ZIP100", "USB-FDD", "USB-ZIP", "USB-CDROM", "USB-HDD", "LAN" and "Disabled".

### **Boot Other Device**

If enabled, this option enables the BIOS to load the OS from another device rather than the ones that have been specified as the first, second and third boot up devices. The settings are "**Enabled**" and "Disabled".

### **Virus Warning**

This item allows the user to choose the VIRUS Warning feature for IDE Hard Drive Disk boot sector protection. If this function is enabled and someone attempts to write data into this area, the BIOS will display a warning message and an alarm will sound. The settings are "Enabled", and "**Disabled**".

### **Boot Up Floppy Seek**

Set this option to "Enabled" to allow the BIOS to test floppy drives to determine whether they have 40 tracks or 80 tracks. The settings are "Enabled" or "**Disabled**".

## 4-8 Security

Choose Security from the Award BIOS main menu with the Left/Right arrow keys. You should see the following display:

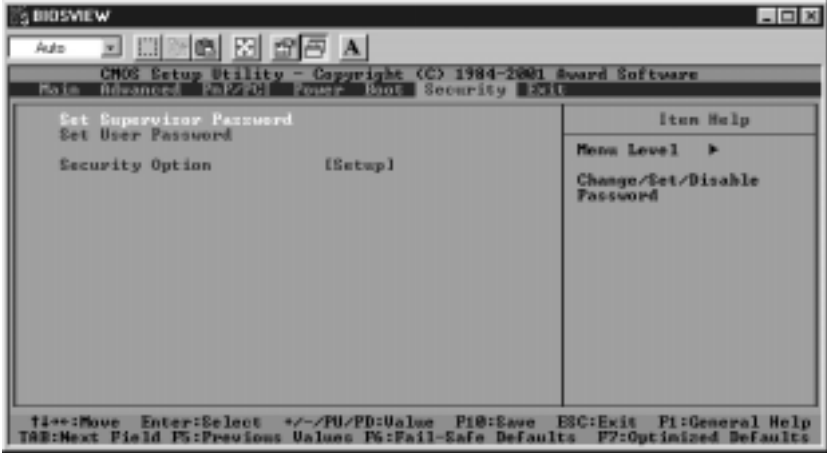

### Set Supervisor Password

When the item "Set Supervisor Password" is highlighted on the above screen, press the <Enter> key. When prompted, type the Supervisor Password in the dialogue box to set or to change the Supervisor Password.

### Set User Password

When the item "Set User Password" is highlighted on the above screen, press the <Enter> key. When prompted, type the User Password in the dialogue box to set or to change the User Password.

### Security Option

This setting allows the user to determine if the password is required every time when the system boots up or if the password is required only when you enter the CMOS setup. The options are "System" and "**Setup**".

## 4-9 Exit

Choose Exit from the Award BIOS main menu with the Left/Right arrow keys. You should see the following display:

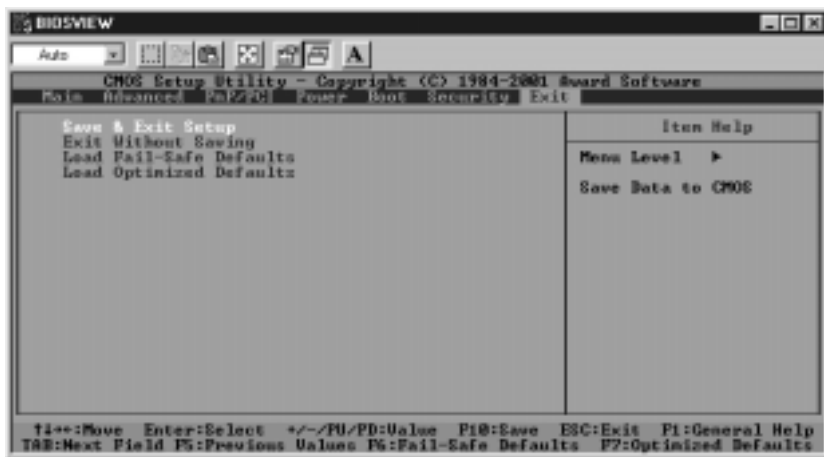

### Save & Exit Setup

When the item "Save & Exit Setup" is highlighted, press <Enter> to save the changes you've made in the BIOS program (CMOS) and exit. Your system should, then, continue with the boot-up procedure.

### Exit without Saving

When the item "Exit without Saving" is highlighted, press <Enter> to exit the Setup routine without saving any changes you may have made. Your system should then continue with the boot-up procedure.

### Load Fail-Safe Defaults

Highlight this item and hit <Enter> to load the default settings for all items in the BIOS Setup. These are the safest settings to use.

### Load Optimized Defaults

Highlight this item and hit <Enter> to load the optimized settings for all items in the BIOS Setup. These settings provide you with optimal system performance.

## Appendix A

# AwardBIOS POST Messages

During the Power-On Self-Test (POST), the BIOS will check for errors. If an error is found and a correction is needed, the BIOS will activate an alarm or display a message.

If a message is displayed, it will be accompanied by the following:

PRESS F1 TO CONTINUE, CTRL-ALT-ESC OR DEL TO ENTER SETUP

### POST Beep Codes

Currently, there are two kinds of beep codes used in AwardBIOS. One code indicates that a video error has occurred and that the BIOS cannot initialize the video screen to display any additional information. This beep code consists of a single long beep followed by two short beeps. The other code indicates that a Rambus error has occurred. This beep code consists of a single long beep that sounds repeatedly.

### Error Messages

One or more of the following messages may be displayed if the BIOS detects an error during the POST. This list includes messages for both the ISA and the EISA BIOS.

#### **CMOSBATTERYHASFAILED**

The CMOS battery is no longer functional. It should be replaced.

#### **CMOSCHECKSUMERROR**

The CMOS checksum is incorrect. This can indicate that CMOS has been corrupted. This error may have been caused by a weak battery. Check the battery and replace if necessary.

#### **DISKBOOTFAILURE,INSERTSYSTEMDISKANDPRESSEENTER**

No boot device was found. This could mean that either a boot drive was not detected or the drive does not contain the proper system boot files. Insert a system disk into Drive A: and press <Enter>. If you assumed the system would boot from the hard drive, make sure the controller is inserted correctly and all cables are properly attached. Also make sure the disk has been formatted as a boot device. Then reboot the system.

## **DISKETTE DRIVES OR TYPES MISMATCH ERROR - RUN SETUP**

The type of diskette drive installed in the system is different from the CMOS definition. Run Setup to reconfigure the drive type correctly.

## **DISPLAY SWITCH IS SET INCORRECTLY**

The display switch on the motherboard can be set to either monochrome or color. This indicates that the switch is set to a different setting than indicated in Setup. Determine which setting is correct, and then either turn off the system and change the jumper or enter Setup and change the VIDEO selection.

## **DISPLAY TYPE HAS CHANGED SINCE LAST BOOT**

Since last powering off the system, the display adapter has been changed. You must configure the system for the new display type.

## **ERROR ENCOUNTERED INITIALIZING HARD DRIVE**

The hard drive cannot be initialized. Be sure the adapter is installed correctly and all cables are correctly and firmly attached. Also be sure the correct hard drive type is selected in Setup.

## **ERROR INITIALIZING HARD DISK CONTROLLER**

Cannot initialize the controller. Make sure the cord is correctly and firmly installed in the bus. Be sure the correct hard drive type is selected in Setup. Also check to see if any jumper needs to be set correctly on the hard drive.

## **FLOPPY DISK CNTRLR ERROR OR NO CNTRLR PRESENT**

Cannot find or initialize the floppy drive controller. Make sure the controller is installed correctly and firmly. If there are no floppy drives installed, be sure the Diskette Drive selection in Setup is set to NONE.

## **KEYBOARD ERROR OR NO KEYBOARD PRESENT**

Cannot initialize the keyboard. Make sure the keyboard is attached correctly and no keys are being pressed during boot up.

If you are intentionally configuring the system without a keyboard, set the error halt condition in Setup to HALT ON ALL, BUT KEYBOARD. This will cause the BIOS to ignore the missing keyboard and continue the boot.

### **Memory Address Error at ...**

Indicates a memory address error at a specific location. You can use this location along with the memory map for your system to find and replace the bad memory chips.

### **Memory parity Error at ...**

Indicates a memory parity error at a specific location. You can use this location along with the memory map for your system to find and replace the bad memory chips.

### **Memory Verify Error at ...**

Indicates an error verifying a value already written to memory. Use the location along with your system's memory map to locate the bad chip.

### **OFFENDING ADDRESS NOT FOUND**

This message is used in conjunction with the I/O CHANNEL CHECK and RAM PARITY ERROR messages when the segment that has caused the problem cannot be isolated.

### **OFFENDING SEGMENT:**

This message is used in conjunction with the I/O CHANNEL CHECK and RAM PARITY ERROR messages when the segment that has caused the problem has been isolated.

### **PRESS A KEY TO REBOOT**

This will be displayed at the bottom screen when an error occurs that requires you to reboot. Press any key and the system will reboot.

### **PRESS F1 TO DISABLE NMI, F2 TO REBOOT**

When BIOS detects a Non-maskable Interrupt condition during boot, this will allow you to disable the NMI and continue to boot, or you can reboot the system with the NMI enabled.

### **RAM PARITY ERROR - CHECKING FOR SEGMENT ...**

Indicates a parity error in Random Access Memory.

### **SYSTEM HALTED, (CTRL-ALT-DEL) TO REBOOT ...**

Indicates the present boot attempt has been aborted and the system must be rebooted. Press and hold down the CTRL and ALT keys and press DEL.

**FLOPPY DISK(S) fail (80) ® Unable to reset floppy subsystem.**

**FLOPPY DISK(S) fail (40) ® Floppy Type mismatch.**

**Hard Disk(s) fail (80) ® HDD reset failed**

**Hard Disk(s) fail (40) ® HDD controller diagnostics failed.**

**Hard Disk(s) fail (20) ® HDD initialization error.**

**Hard Disk(s) fail (10) ® Unable to recalibrate fixed disk.**

**Hard Disk(s) fail (08) ® Sector Verify failed.**

**Keyboard is locked out - Unlock the key.**

BIOS detect the keyboard is locked. P17 of the keyboard controller is pulled low.

**Keyboard error or no keyboard present.**

Cannot initialize the keyboard. Make sure that the keyboard is attached correctly and no keys are being pressed during the boot.

**Manufacturing POST loop.**

System will repeat POST procedure infinitely while the P15 of keyboard controller is pulled low. This is also used for M/B burn in testing.

**BIOS ROM checksum error - System halted.**

The checksum of ROM address F0000H-FFFFFFH is bad.

**Memory test fail..**

BIOS reports the a memory test fail if the onboard memory has an error.

## Appendix B

### AwardBIOS POST Codes

This section lists the POST (Power On Self Testing) Codes for the Award BIOS.

POST (hex)	Description
CFh	Test CMOS R/W functionality.
C0h	Early chipset initialization: -Disable shadow RAM -Disable L2 cache (socket 7 or below) -Program basic chipset registers
C1h	Detect memory -Auto-detection of DRAM size, type and ECC. -Auto-detection of L2 cache (socket 7 or below)
C3h	Expand compressed BIOS code to DRAM
C5h	Call chipset hook to copy BIOS back to E000 & F000 shadow RAM.
0h1	Expand the Xgroup codes locating in physical address 1000:0
02h	Reserved
03h	Initial Superio_Early_Init switch.
04h	Reserved
05h	1. Blank out screen 2. Clear CMOS error flag
06h	Reserved
07h	1. Clear 8042 interface 2. Initialize 8042 self-test
08h	1. Test special keyboard controller for Winbond 977 series Super I/O chips. 2. Enable keyboard interface.
09h	Reserved
0Ah	<ul style="list-style-type: none"> <li>● Disable PS/2 mouse interface (optional).</li> <li>● Auto detect ports for keyboard &amp; mouse followed by a port &amp; interface swap (optional).</li> <li>● Reset keyboard for Winbond 977 series Super I/O chips.</li> </ul>
0Bh	Reserved
0Ch	Reserved
0Dh	Reserved
0Eh	Test F000h segment shadow to see whether it is R/W-able or not. If test fails, keep beeping the speaker.

### Debuggig LED Encoding

Post Code	Encoded LED	Task
C1h	001b	Memory Detection
05h	010b	BIOS Shadowing
07h	011b	KBC Initialization
0Eh	100b	Shadow RAM test
14h	101b	Chipset defaults loaded
26h	110b	Clock generator configured
2Bh	111b	Video initialization
52h	000b	Just clear LEDs

**POST (hex)                      Description**

0Fh	Reserved
10h	Auto detect flash type to load appropriate flash R/W codes into the run time area in F000 for ESCD & DMI support.
11h	Reserved
12h	Use walking 1's algorithm to check out interface in CMOS circuitry. Also set real-time clock power status, and then check for override.
13h	Reserved
14h	Program chipset default values into chipset. Chipset default values are MODBINable by OEM customers.
15h	Reserved
16h	Initial Early_Init_Onboard_Generator switch.
17h	Reserved
18h	Detect CPU information including brand, SMI type (Cyrix or Intel) and CPU level (586 or 686).
19h	Reserved
1Ah	Reserved
1Bh	Initial interrupts vector table. If no special specified, all H/W interrupts are directed to SPURIOUS_INT_HDLR & S/W interrupts to SPURIOUS_soft_HDLR.
1Ch	Reserved
1Dh	Initial EARLY_PM_INIT switch.
1Eh	Reserved
1Fh	Load keyboard matrix (notebook platform)
20h	Reserved
21h	HPM initialization (notebook platform)
22h	Reserved
23h	<ol style="list-style-type: none"> <li>1. Check validity of RTC value: e.g. a value of 5Ah is an invalid value for RTC minute.</li> <li>2. Load CMOS settings into BIOS stack. If CMOS checksum fails, use default value instead.</li> <li>3. Prepare BIOS resource map for PCI &amp; PnP use. If ESCD is valid, take into consideration of the ESCD's legacy information.</li> <li>4. Onboard clock generator initialization. Disable respective clock resource to empty PCI &amp; DIMM slots.</li> <li>5. Early PCI initialization: <ul style="list-style-type: none"> <li>-Enumerate PCI bus number</li> <li>-Assign memory &amp; I/O resource</li> <li>-Search for a valid VGA device &amp; VGA BIOS, and put it into C000:0.</li> </ul> </li> </ol>
24h	Reserved
25h	Reserved
26h	Reserved
27h	Initialize INT 09 buffer
28h	Reserved
29h	<ul style="list-style-type: none"> <li>● Program CPU internal MTRR (P6 &amp; PII) for 0-640K memory address.</li> <li>● Initialize the APIC for Pentium class CPU.</li> <li>● Program early chipset according to CMOS setup. Example: onboard IDE controller.</li> <li>● Measure CPU speed.</li> <li>● Invoke video BIOS.</li> </ul>
2Ah	Reserved
2Bh	Reserved
2Ch	Reserved

POST (hex)	Description
2Dh	1. Initialize multi-language 2. Put information on screen display, including Award title, CPU type, CPU speed ....
2Eh	Reserved
2Fh	Reserved
30h	Reserved
31h	Reserved
32h	Reserved
33h	Reset keyboard except Winbond 977 series Super I/O chips.
34h	Reserved
35h	Reserved
36h	Reserved
37h	Reserved
38h	Reserved
39h	Reserved
3Ah	Reserved
3Bh	Reserved
3Ch	Test 8254
3Dh	Reserved
3Eh	Test 8259 interrupt mask bits for channel 1.
3Fh	Reserved
40h	Test 8259 interrupt mask bits for channel 2.
41h	Reserved
42h	Reserved
43h	Test 8259 functionality.
44h	Reserved
45h	Reserved
46h	Reserved
47h	Initialize EISA slot
48h	Reserved
49h	1. Calculate total memory by testing the last double word of each 64K page. 2. Program writes allocation for AMD K5 CPU.
4Ah	Reserved
4Bh	Reserved
4Ch	Reserved
4Dh	Reserved
4Eh	1. Program MTRR of M1 CPU 2. Initialize L2 cache for P6 class CPU & program CPU with proper cacheable range. 3. Initialize the APIC for P6 class CPU. 4. On MP platform, adjust the cacheable range to smaller one in case the cacheable ranges between each CPU are not identical.
4Fh	Reserved
50h	Initialize USB
51h	Reserved
52h	Test all memory (clear all extended memory to 0)
53h	Reserved
54h	Reserved
55h	Display number of processors (multi-processor platform)
56h	Reserved
57h	1. Display PnP logo 2. Early ISA PnP initialization -Assign CSN to every ISA PnP device.

POST (hex)	Description
58h	Reserved
59h	Initialize the combined Trend Anti-Virus code.
5Ah	Reserved
5Bh	(Optional Feature) Show message for entering AWDFLASH.EXE from FDD (optional)
5Ch	Reserved
5Dh	1. Initialize Init_Onboard_Super_IO switch. 2. Initialize Init_Onboard_AUDIO switch.
5Eh	Reserved
5Fh	Reserved
60h	Okay to enter Setup utility; i.e. not until this POST stage can users enter the CMOS setup utility.
61h	Reserved
62h	Reserved
63h	Reserved
64h	Reserved
65h	Initialize PS/2 Mouse
66h	Reserved
67h	Prepare memory size information for function call: INT 15h ax=E820h
68h	Reserved
69h	Turn on L2 cache
6Ah	Reserved
6Bh	Program chipset registers according to items described in Setup & Auto-configuration table.
6Ch	Reserved
6Dh	1. Assign resources to all ISA PnP devices. 2. Auto assign ports to onboard COM ports if the corresponding item in Setup is set to "AUTO".
6Eh	Reserved
6Fh	1. Initialize floppy controller 2. Set up floppy related fields in 40:hardware.
70h	Reserved
71h	Reserved
72h	Reserved
73h	(Optional Feature) Enter AWDFLASH.EXE if : -AWDFLASH is found in floppy drive. -ALT+F2 is pressed
74h	Reserved
75h	Detect & install all IDE devices: HDD, LS120, ZIP, CDROM.....
76h	Reserved
77h	Detect serial ports & parallel ports.
78h	Reserved
79h	Reserved
7Ah	Detect & install co-processor
7Bh	Reserved
7Ch	Reserved
7Dh	Reserved
7Eh	Reserved
7Fh	1. Switch back to text mode if full screen logo is supported. -If errors occur, report errors & wait for keys -If no errors occur or F1 key is pressed to continue: •Clear EPA or customization logo.

POST (hex)	Description
80h	Reserved
81h	Reserved
82h	<ol style="list-style-type: none"> <li>1. Call chipset power management hook.</li> <li>2. Recover the text font used by EPA logo (not for full screen logo)</li> <li>3. If password is set, ask for password.</li> </ol>
83h	Save all data in stack back to CMOS
84h	Initialize ISA PnP boot devices
85h	<ol style="list-style-type: none"> <li>1. USB final Initialization</li> <li>2. NET PC: Build SYSID structure</li> <li>3. Switch screen back to text mode</li> <li>4. Set up ACPI table at top of memory.</li> <li>5. Invoke ISA adapter ROMs</li> <li>6. Assign IRQs to PCI devices</li> <li>7. Initialize APM</li> <li>8. Clear noise of IRQs.</li> </ol>
86h	Reserved
87h	Reserved
88h	Reserved
89h	Reserved
90h	Reserved
91h	Reserved
92h	Reserved
93h	Read HDD boot sector information for Trend Anti-Virus code
94h	<ol style="list-style-type: none"> <li>1. Enable L2 cache</li> <li>2. Program boot up speed</li> <li>3. Chipset final initialization.</li> <li>4. Power management final initialization</li> <li>5. Clear screen &amp; display summary table</li> <li>6. Program K6 write allocation</li> <li>7. Program P6 class write combining</li> </ol>
95h	<ol style="list-style-type: none"> <li>1. Program daylight saving</li> <li>2. Update keyboard LED &amp; typematic rate</li> </ol>
96h	<ol style="list-style-type: none"> <li>1. Build MP table</li> <li>2. Build &amp; update ESCD</li> <li>3. Set CMOS century to 20h or 19h</li> <li>4. Load CMOS time into DOS timer tick</li> <li>5. Build MSIRQ routing table.</li> </ol>
FFh	Boot attempt (INT 19h)

## Notes

---

---

## Appendix C

### AwardBIOS Error Beep Codes

This section lists the Award BIOS Error Beep Codes.

<b>Beep Code</b>	<b>Error Message Description</b>
1 short beep	System boot.
2 short beeps	Incorrect CMOS setting.
1 long + 1 short	DRAM error.
1 long + 2 short	VGA error.
1 long + 3 short	Keyboard error.
1 long + 9 short	ROM error.
Long beeps	Memory module error.
High beeps	Power error.

## Notes