

SUPER ●[®]

C7B250-CB-ML

USER'S MANUAL

Revision 1.0a

The information in this User's Manual has been carefully reviewed and is believed to be accurate. The vendor assumes no responsibility for any inaccuracies that may be contained in this document, makes no commitment to update or to keep current the information in this manual, or to notify any person or organization of the updates. **Please Note: For the most up-to-date version of this manual, please see our website at www.supermicro.com.**

Super Micro Computer, Inc. ("Supermicro") reserves the right to make changes to the product described in this manual at any time and without notice. This product, including software and documentation, is the property of Supermicro and/or its licensors, and is supplied only under a license. Any use or reproduction of this product is not allowed, except as expressly permitted by the terms of said license.

IN NO EVENT WILL SUPERMICRO BE LIABLE FOR DIRECT, INDIRECT, SPECIAL, INCIDENTAL, SPECULATIVE OR CONSEQUENTIAL DAMAGES ARISING FROM THE USE OR INABILITY TO USE THIS PRODUCT OR DOCUMENTATION, EVEN IF ADVISED OF THE POSSIBILITY OF SUCH DAMAGES. IN PARTICULAR, SUPERMICRO SHALL NOT HAVE LIABILITY FOR ANY HARDWARE, SOFTWARE, OR DATA STORED OR USED WITH THE PRODUCT, INCLUDING THE COSTS OF REPAIRING, REPLACING, INTEGRATING, INSTALLING OR RECOVERING SUCH HARDWARE, SOFTWARE, OR DATA.

Any disputes arising between manufacturer and customer shall be governed by the laws of Santa Clara County in the State of California, USA. The State of California, County of Santa Clara shall be the exclusive venue for the resolution of any such disputes. Super Micro's total liability for all claims will not exceed the price paid for the hardware product.

FCC Statement: This equipment has been tested and found to comply with the limits for a class B digital device, pursuant to Part 15 of the FCC Rules. These limits are designed to provide reasonable protection against harmful interference in a residential installation. This equipment generates, uses, and can radiate radio frequency energy and, if not installed and used in accordance with the instructions, may cause harmful interference to radio communications. However, there is no guarantee that interference will not occur in a particular installation. If this equipment does cause harmful interference to radio or television reception, which can be determined by turning the equipment off and on, the user is encouraged to try to correct the interference by one or more of the following measures:

- Reorient or relocate the receiving antenna.
- Increase the separation between the equipment and receiver.
- Connect the equipment to an outlet on a circuit different from that to which the receiver is connected.
- Consult the authorized dealer or an experienced radio/TV technician for help.

California Best Management Practices Regulations for Perchlorate Materials: This Perchlorate warning applies only to products containing CR (Manganese Dioxide) Lithium coin cells. "Perchlorate Material-special handling may apply. See www.dtsc.ca.gov/hazardouswaste/perchlorate"



WARNING: This product can expose you to chemicals including lead, known to the State of California to cause cancer and birth defects or other reproductive harm. For more information, go to www.P65Warnings.ca.gov.

Manual Revision 1.0a
Release Date: June 25, 2019

Unless you request and receive written permission from Super Micro Computer, Inc., you may not copy any part of this document.

Information in this document is subject to change without notice. Other products and companies referred to herein are trademarks or registered trademarks of their respective companies or mark holders.

Copyright © 2019 by Super Micro Computer, Inc. All rights reserved.
Printed in the United States of America

Preface

This manual is written for system integrators, PC technicians and knowledgeable PC users. It provides information for the installation and use of the **SUPER** C7B250-CB-ML motherboard.

Manual Organization

Chapter 1 describes the features, specifications and performance of the motherboard, and provides detailed information on the Intel B250 Express chipset.

Chapter 2 provides hardware installation instructions. Read this chapter when installing the processor, memory modules and other hardware components into the system.

If you encounter any problems, see **Chapter 3**, which describes troubleshooting procedures for video, memory and system setup stored in the CMOS.

Chapter 4 includes an introduction to the BIOS, and provides detailed information on running the CMOS Setup utility.

Appendix A provides BIOS Error Beep Codes.

Appendix B lists software program installation instructions.

Appendix C contains BIOS Recovery instructions.

Appendix D contains an introduction and instructions regarding the Dual Boot Block feature of this motherboard.

Checklist

Congratulations on purchasing your computer motherboard from an acknowledged leader in the industry. Supermicro boards are designed with the utmost attention to detail to provide you with the highest standards in quality and performance.

Please check that the following items have all been included with your motherboard. If anything listed here is damaged or missing, contact your retailer.

The following items are included in the retail box:

- One (1) Supermicro Motherboard
- Two (2) SATA Cables
- One (1) I/O Shield
- One (1) Quick Reference Guide
- One (1) Driver CD

Conventions Used in the Manual

Special attention should be given to the following symbols for proper installation and to prevent damage done to the components or injury to yourself:



Attention! Critical information to prevent damage to the components or injury to yourself.



Important: Important information given to ensure proper system installation or to relay safety precautions.



Note: Additional Information given to differentiate various models or provides information for correct system setup.

Standardized Warning Statements

The following statements are industry-standard warnings, provided to warn the user of situations which have the potential for bodily injury. Should you have questions or experience difficulty, contact Supermicro's Technical Support department for assistance. Only certified technicians should attempt to install or configure components.

Read this section in its entirety before installing or configuring components in the Supermicro chassis.

Battery Handling



Warning!

There is a danger of explosion if the battery is replaced incorrectly. Replace the battery only with the same or equivalent type recommended by the manufacturer. Dispose of used batteries according to the manufacturer's instructions

電池の取り扱い

電池交換が正しく行われなかった場合、破裂の危険性があります。交換する電池はメーカーが推奨する型、または同等のものを使用下さい。使用済電池は製造元の指示に従って処分して下さい。

警告

電池更換不當會有爆炸危險。請只使用同類電池或製造商推薦的功能相當的電池更換原有電池。請按製造商的說明處理廢舊電池。

警告

電池更換不當會有爆炸危險。請使用製造商建議之相同或功能相當的電池更換原有電池。請按照製造商的說明指示處理廢棄舊電池。

Warnung

Bei Einsetzen einer falschen Batterie besteht Explosionsgefahr. Ersetzen Sie die Batterie nur durch den gleichen oder vom Hersteller empfohlenen Batterietyp. Entsorgen Sie die benutzten Batterien nach den Anweisungen des Herstellers.

Attention

Danger d'explosion si la pile n'est pas remplacée correctement. Ne la remplacer que par une pile de type semblable ou équivalent, recommandée par le fabricant. Jeter les piles usagées conformément aux instructions du fabricant.

iAdvertencia!

Existe peligro de explosión si la batería se reemplaza de manera incorrecta. Reemplazar la batería exclusivamente con el mismo tipo o el equivalente recomendado por el fabricante. Desechar las baterías gastadas según las instrucciones del fabricante.

אזהרה!

קיימת סכנת פיצוץ של הסוללה במידה והוחלפה בדרך לא תקינה. יש להחליף את הסוללה בסוג התואם מחברת יצרן מומלצת.

סילוק הסוללות המשומשות יש לבצע לפי הוראות היצרן.

هناك خطر من انفجار في حالة استبدال البطارية بطريقة غير صحيحة فعليك استبدال البطارية فقط بنفس النوع أو ما يعادلها كما أوصت به الشركة المصنعة تخلص من البطاريات المستعملة وفقا لتعليمات الشركة الصانعة

경고!

배터리가 올바르게 교체되지 않으면 폭발의 위험이 있습니다. 기존 배터리와 동일하거나 제조사에서 권장하는 동등한 종류의 배터리로만 교체해야 합니다. 제조사의 안내에 따라 사용된 배터리를 처리하여 주십시오.

Waarschuwing

Er is ontploffingsgevaar indien de batterij verkeerd vervangen wordt. Vervang de batterij slechts met hetzelfde of een equivalent type die door de fabrikant aanbevolen wordt. Gebruikte batterijen dienen overeenkomstig fabrieksvoorschriften afgevoerd te worden.

Product Disposal



Warning!

Ultimate disposal of this product should be handled according to all national laws and regulations.

製品の廃棄

この製品を廃棄処分する場合、国の関係する全ての法律・条例に従い処理する必要があります。

警告

本产品的废弃处理应根据所有国家的法律和规章进行。

警告

本產品的廢棄處理應根據所有國家的法律和規章進行。

Warnung

Die Entsorgung dieses Produkts sollte gemäß allen Bestimmungen und Gesetzen des Landes erfolgen.

iAdvertencia!

Al deshacerse por completo de este producto debe seguir todas las leyes y reglamentos nacionales.

Attention

La mise au rebut ou le recyclage de ce produit sont généralement soumis à des lois et/ou directives de respect de l'environnement. Renseignez-vous auprès de l'organisme compétent.

סילוק המוצר

אזהרה!

סילוק סופי של מוצר זה חייב להיות בהתאם להנחיות וחוקי המדינה.

عند التخلص النهائي من هذا المنتج ينبغي التعامل معه وفقا لجميع القوانين واللوائح الوطنية

경고!

이 제품은 해당 국가의 관련 법규 및 규정에 따라 폐기되어야 합니다.

Waarschuwing

De uiteindelijke verwijdering van dit product dient te geschieden in overeenstemming met alle nationale wetten en reglementen.

Contacting Supermicro

Headquarters

Address: Super Micro Computer, Inc.
980 Rock Ave.
San Jose, CA 95131 U.S.A.

Tel: +1 (408) 503-8000

Fax: +1 (408) 503-8008

Email: marketing@supermicro.com (General Information)
support@supermicro.com (Technical Support)

Website: www.supermicro.com

Europe

Address: Super Micro Computer B.V.
Het Sterrenbeeld 28, 5215 ML
's-Hertogenbosch, The Netherlands

Tel: +31 (0) 73-6400390

Fax: +31 (0) 73-6416525

Email: sales@supermicro.nl (General Information)
support@supermicro.nl (Technical Support)
rma@supermicro.nl (Customer Support)

Website: www.supermicro.nl

Asia-Pacific

Address: Super Micro Computer, Inc.
3F, No. 150, Jian 1st Rd.
Zhonghe Dist., New Taipei City 235
Taiwan (R.O.C)

Tel: +886-(2) 8226-3990

Fax: +886-(2) 8226-3992

Email: support@supermicro.com.tw

Website: www.supermicro.com.tw

Where to Find More Information

For your system to work properly, please follow the links below to download all necessary drivers/utilities and the user's manual for your motherboard.

SMCI product manuals: <http://www.supermicro.com/support/manuals/>

Product Drivers and utilities: <https://www.supermicro.com/wftp/driver/>

If you have any questions, please contact our support team at support@supermicro.com.

Table of Contents

Preface

Manual Organization	iii
Checklist	iv
Conventions Used in the Manual	iv
Standardized Warning Statements	v
Battery Handling.....	v
Product Disposal.....	vi
Contacting Supermicro.....	viii
Where to Find More Information.....	ix

Chapter 1 Introduction

1-1 Overview	1-1
About this Motherboard	1-1
1-2 Chipset Overview	1-1
Intel B250 Express Chipset Features	1-1
1-3 Motherboard Features.....	1-2
1-4 Special Features	1-4
Recovery from AC Power Loss	1-4
1-5 PC Health Monitoring.....	1-4
Fan Status Monitor and Control	1-4
Environmental Temperature Control	1-4
System Resource Alert	1-5
1-6 ACPI Features	1-5
Slow Blinking LED for Suspend-State Indicator.....	1-5
1-7 Power Supply	1-6
1-8 Super I/O	1-6

Chapter 2 Installation

2-1 Installation Components and Tools Needed	2-1
2-2 Static-Sensitive Devices.....	2-2
Precautions	2-2
Unpacking.....	2-2
2-3 Processor and Heatsink Installation.....	2-3
Installing the LGA1151 Processor	2-3
Installing an Active CPU Heatsink with Fan	2-6
Removing the Heatsink.....	2-8
2-4 Installing DDR4 Memory	2-9
DIMM Installation	2-9

	Removing Memory Modules.....	2-9
	Memory Support.....	2-10
	Memory Population Guidelines.....	2-11
2-5	Motherboard Installation.....	2-12
	Tools Needed.....	2-12
	Location of Mounting Holes.....	2-12
	Installing the Motherboard.....	2-13
2-6	Connector and I/O Ports.....	2-14
	I/O Back Panel.....	2-14
	Universal Serial Bus (USB).....	2-15
	Ethernet Port.....	2-16
	Back Panel High Definition Audio (HD Audio).....	2-16
	ATX PS/2 Keyboard/Mouse Port.....	2-17
	VESA® DisplayPort™.....	2-17
	HDMI Port.....	2-17
	DVI Port.....	2-17
	Front Control Panel.....	2-18
	Front Control Panel Pin Definitions.....	2-19
	Power LED.....	2-19
	HDD LED.....	2-19
	NIC1 (LAN).....	2-19
	Overheat (OH)/Fan Fail.....	2-19
	Reset Button.....	2-20
	Power Button.....	2-20
2-7	Connecting Cables.....	2-21
	ATX Main PWR & CPU PWR Connectors.....	2-21
	Fan Headers.....	2-22
	Chassis Intrusion.....	2-22
	COM Connection.....	2-23
	Speaker.....	2-23
	DOM PWR Connector.....	2-24
	SPDIF OUT.....	2-24
	Standby Power Header.....	2-25
	PCI-E M.2 Connector.....	2-25
	Front Panel Audio Header (AUDIO FP).....	2-26
	TPM Header/Port 80.....	2-26
2-8	Jumper Settings.....	2-27
	Explanation of Jumpers.....	2-27
	Manufacturing Mode.....	2-27

JCMOS & JBT1	2-28
PCI-E Slot SMB Enable (I2C1/I2C2).....	2-28
Watch Dog Timer Enable/Disable	2-29
BIOS Recovery Jumper	2-29
USB Wake Up	2-30
2-9 Onboard Indicators.....	2-31
LAN LEDs.....	2-31
Onboard Power LED	2-31
2-10 Hard Drive Connections.....	2-32
SATA Connections (I-SATA0~I-SATA5)	2-32

Chapter 3 Troubleshooting

3-1 Troubleshooting Procedures.....	3-1
Before Power On.....	3-1
No Power.....	3-1
No Video	3-2
Memory Errors	3-2
When the System is Losing the Setup Configuration	3-2
3-2 Technical Support Procedures	3-3
3-3 Frequently Asked Questions	3-4
3-4 Battery Removal and Installation	3-5
Battery Removal.....	3-5
Proper Battery Disposal	3-5
3-5 Returning Motherboard for Service.....	3-6
Battery Installation	3-6

Chapter 4 BIOS

4-1 Introduction	4-1
Starting BIOS GUI Setup Utility.....	4-1
How To Change the Configuration Data	4-2
How to Start the Setup Utility	4-2
4-2 System Information	4-3
System Date	4-3
System Time	4-3
4-3 CPU	4-4
CPU Configuration.....	4-5
SW Guard Extension (SGX)	4-6
CPU Flex Ratio Override.....	4-6
CPU Flex Ratio Settings	4-6
Hardware Prefetcher	4-6

	Adjacent Cache Line Prefetch	4-6
	Intel® (VMX) Virtualization Technology	4-6
	Active Processor Cores.....	4-6
	Hyper-Threading	4-7
	BIST.....	4-7
	AES.....	4-7
	Machine Check.....	4-7
	MonitorMWait.....	4-7
	Intel® Trusted Executed Technology.....	4-7
	Alias Check Request	4-7
	Reset AUX Content.....	4-7
	FCLK Frequency for Early Power On	4-8
	Power and Performance.....	4-8
	CPU - Power Management Control	4-8
	Boot performance Mode	4-8
	Intel(R) SpeedStep(tm)	4-8
	Turbo Mode	4-9
	Platform PL1 Enable	4-9
	Platform PL2 Enable	4-9
	Power Limit 4 Override	4-9
	C states.....	4-9
	Enhanced C-states	4-9
	C-State Auto Demotion	4-9
	C-State Un-demotion	4-9
	Package C-State Demotion	4-10
	Package C-State Un-Demotion	4-10
	IO MWAIT Redirection.....	4-10
	Package C State Limit.....	4-10
	Package C State Workaround.....	4-10
	GT-Power Management.....	4-10
4-4	Memory	4-11
	Memory Scrambler	4-12
	Force ColdReset	4-12
	Channel A DIMM Control	4-12
	Channel B DIMM Control	4-12
	Force Single Rank	4-12
	MRC Fast Boot.....	4-12
4-5	Advanced.....	4-13
	Boot Feature	4-13

Quiet Boot	4-13
Bootup Num-Lock	4-13
Wait for "F1" If Error	4-13
Re-try Boot	4-13
Watch Dog Function	4-13
Power Button Function	4-14
AC Loss Policy Depend On.....	4-14
EuP Support	4-14
NCT6792D Super IO Configuration	4-14
SuperIO Chip NCT6792D.....	4-15
Serial Port 1 Configuration	4-15
Serial Port.....	4-15
Device Settings.....	4-15
Change Settings	4-15
Serial Port Console Redirection	4-15
COM 1	4-15
Console Redirection	4-15
System Agent (SA) Configuration.....	4-19
GMM Device (B0:D8:F0)	4-21
X2APIC Opt Out.....	4-21
Graphics Configuration	4-21
Graphics Turbo IMON Current	4-22
Skip Scanning of External Gfx Card.....	4-22
Primary Display	4-22
Select PCIE Card.....	4-22
External Gfx Card Primary Display Configuration.....	4-22
Internal Graphics	4-22
GTT Size	4-22
Aperture Size	4-22
DVMT Pre-Allocated	4-23
DVMT Total Gfx Mem	4-23
Gfx Low Power Mode	4-23
VDD Enable.....	4-23
HDCP Support	4-23
Algorithm.....	4-23
PM Support	4-23
PAVP Enable.....	4-23
Cdynmax Clamping Enable.....	4-23

Graphics Clock Frequency	4-23
PCH-IO Configuration	4-24
SATA and RST Configuration.....	4-25
SATA Controllers	4-25
SATA Mode Selection	4-25
SATA Controller Speed	4-25
SATA Frozen	4-25
Serial ATA Port.....	4-26
Hot Plug	4-26
Configured as eSATA	4-26
Spin Up Device	4-26
SATA Device Type	4-26
PCH FW Configuration	4-26
ME FW Image Re-Flash.....	4-27
USB Configuration.....	4-28
Legacy USB Support.....	4-28
XHCI Hand-Off.....	4-28
PCIe/PCI/PnP Configuration.....	4-30
Security.....	4-32
Administrator Password.....	4-32
User Password	4-32
Secure Boot	4-33
Attempt Secure Boot	4-33
Secure Boot Mode	4-33
CSM Support	4-33
Key Management	4-34
Provision Factory Default Keys.....	4-34
Install Factory Default Keys.....	4-34
Enroll Efi Image	4-34
Save All Secure Boot Variables	4-34
Platform Key (PK)	4-34
Delete Key Exchange Key.....	4-35
Key Exchange Keys	4-35
Append Key Exchange Key	4-35
Delete Authorized Signature	4-35
Authorized Signatures.....	4-35
Append Authorized Signature.....	4-35
Delete Forbidden Signature	4-36
Forbidden Signatures.....	4-36

	Append Forbidden Signature.....	4-36
	Delete Authorized TimeStamps	4-36
	Authorized TimeStamps	4-36
	Append Authorized TimeStamp	4-36
	Delete OSRecovery Signatures.....	4-37
	OsRecovery Signatures	4-37
	Append OsRecovery Signature	4-37
4-6	Thermal & Fan.....	4-38
	Fan Control.....	4-39
	Fan Speed Control Mode	4-39
4-7	Save & Exit.....	4-40
	Boot mode select	4-40
	FIXED BOOT ORDER Priorities.....	4-40
	Legacy Boot Option #1~#8.....	4-40
	USB Key Drive BBS Priorities.....	4-40
	NETWORK Drive BBS Priorities.....	4-40
	Boot Override	4-40
	SMI USB DISK 1100.....	4-41
	Launch EFI Shell from filesystem device	4-41
4-8	BIOS Update	4-42
	Start Update	4-42

Appendix A BIOS Error Beep Codes

A-1	BIOS Error Beep Codes	A-1
-----	-----------------------------	-----

Appendix B Software Installation Instructions

B-1	Installing Drivers	B-1
B-2	Configuring SuperDoctor® 5	B-2

Appendix C BIOS Recovery Instructions

C-1	An Overview to the BIOS.....	C-1
C-2	How to Recover the BIOS Image (-the Main BIOS Block).....	C-1
C-3	To Recover the Main BIOS Block Using a USB-Attached Device....	C-2

Appendix D Dual Boot Block

D-1	Introduction	D-1
	BIOS Boot Block	D-1
	BIOS Boot Block Corruption Occurrence	D-1
D-2	Steps to Reboot the System by switch JBR1	D-2

Chapter 1

Introduction

1-1 Overview

About this Motherboard

The C7B250-CB-ML motherboard supports a single 6th and 7th Generation Intel® Core™ i7/i5/i3, Pentium®/Celeron® processor in an LGA 1151 (H4) socket. With the Intel B250 Express chipset built in, the C7B250-CB-ML motherboard offers substantial system performance and storage capability for overclocking platforms in a small form factor. Please refer to our website (<http://www.supermicro.com/products/>) for processor and memory support updates.

1-2 Chipset Overview

Intel B250 Express Chipset Features

- Direct Media Interface (up to 10 Gb/s transfer, Full Duplex)
- Intel Matrix Storage Technology and Intel Rapid Storage Technology
- Intel Optane technology support
- Intel I/O Virtualization (VT-d) Support
- Intel Trusted Execution Technology Support
- PCI Express 3.0 Interface (up to 8 GT/s)
- SATA Controller (up to 6Gb/sec)
- Advanced Host Controller Interface (AHCI)

1-3 Motherboard Features

CPU	Single 6th and 7th Generation Intel Core i7/i5/i3, Pentium/Celeron processor in an LGA1151 type socket, up to 65W TDP	
Memory	Four (4) slots support up to 64GB of unbuffered, non-ECC, 2400MHz DDR4 memory*	
	Dual-channel memory	
	DIMM sizes	
	UDIMM	4GB, 8GB, 16GB
Chipset	Intel B250 Express	
Expansion Slots	One (1) PCH PCI-E 3.0 x1 slot	
	One (1) PCH PCI-E 3.0 x4 slot	
	One (1) CPU PCI-E 3.0 x16 slot	
	One (1) NVMe PCI-E x4 M.2	
Network Connections	One (1) Gigabit Ethernet Controller	
	One (1) RJ-45 rear I/O panel connector with Link and Activity LEDs	
I/O Devices	Hard Drive Connections	
	SATA 3.0 (6Gb/s)	Six (6) I-SATA 0~5
	USB Devices	
	Four (4) USB 3.0 and two (2) USB 2.0 ports on the I/O back panel	
	Two (2) front accessible USB 2.0 ports on one header	
	Two (2) front accessible USB 3.0 ports on one header	
	Keyboard/Mouse	
	One shared PS/2 Keyboard/Mouse port on the I/O back panel	
	Other I/O Ports	
	One (1) VESA DisplayPort, One (1) DVI-D Port	
	One (1) HDMI 1.4 Port	
	One (1) Serial header (COM1)	
	Audio	
	One set of High Definition Audio 7.1 channel connectors supported by Realtek ALC888S on the back panel	
One (1) Front Panel Audio Header		
One (1) S/PDIF Out on the rear side of the chassis		

	Super I/O
	Nuvoton NCT6792D-B
BIOS	128 Mb AMI BIOS® SPI Flash BIOS
	Plug and Play (PnP), DMI 2.8, PCI 2.3, ACPI 1.0/2.0/3.0, and USB Keyboard
Power Configuration	ACPI/ASPM Power Management
	Main Switch Override Mechanism
	Internal/External Modem Ring-On
	Power-on mode for AC power recovery
Health Monitoring	CPU Monitoring
	Onboard monitors: CPU core, +3.3V, +5V, +/- 12V, +3.3V Stby, VBAT, HT, Memory PCH Temperature, System Temperature, and CPU Temperature
	CPU 3+2 phase switching voltage regulator
	CPU/System overheat LED and control
	CPU Thermal Trip support
	Thermal Monitor support
	Fan Control
	Fan status monitoring with 4-pin fan speed control
	Low noise fan speed control
	System Management
System resource alert via SuperDoctor® 5	
SuperDoctor 5	
Chassis Intrusion header and detection	
CD Utilities	BIOS flash upgrade utility
	Drivers and software for Intel B250 Express chipset utilities
Other	ROHS 6/6 (Full Compliance, Lead Free)
Dimensions	Micro ATX form factor (9.6" x 9.6") (243.84 mm x 243.84 mm)



Note: Memory modules having frequency of more than 2400MHz is not the JEDEC memory standard. Compatibility and stability of these memory modules depend on varying factors including the processor's capabilities and other devices installed.

1-4 Special Features

Recovery from AC Power Loss

Basic I/O System (BIOS) provides a setting for you to determine how the system will respond when AC power is lost and then restored to the system. You can choose for the system to remain powered off, (in which case you must press the power switch to turn it back on), or for it to automatically return to a power-on state. Refer to the Advanced BIOS Setup section to change this setting. The default setting is **Last State**.

1-5 PC Health Monitoring

This section describes the PC health monitoring features of the board. All have an onboard System Hardware Monitoring chip that supports PC health monitoring. An onboard voltage monitor will scan these onboard voltages continuously: CPU core, +3.3V, +5V, +/- 12V, +3.3V Stby, +5V Stby, VBAT, HT, Memory PCH Temperature, System Temperature, and CPU Temperature. Once a voltage becomes unstable, a warning is given, or an error message is sent to the screen. The user can adjust the voltage thresholds to define the sensitivity of the voltage monitor.

Fan Status Monitor and Control

PC health monitoring in the BIOS can check the RPM status of the cooling fans. The onboard CPU and chassis fans are controlled by Thermal Management via SIO.

Environmental Temperature Control

The thermal control sensor monitors the CPU temperature in real time and will turn on the thermal control fan whenever the CPU temperature exceeds a user-defined threshold. The overheat circuitry runs independently from the CPU. Once the thermal sensor detects that the CPU temperature is too high, it will automatically turn on the thermal fans to prevent the CPU from overheating. The onboard chassis thermal circuitry can monitor the overall system temperature and alert the user when the chassis temperature is too high.



Note: To avoid possible system overheating, please be sure to provide adequate airflow to your system.

System Resource Alert

This feature is available when the system is used with SuperDoctor 5 in the Windows OS environment or used with SuperDoctor II in Linux. SuperDoctor is used to notify the user of certain system events. For example, you can configure SuperDoctor to provide you with warnings when the system temperature, CPU temperatures, voltages and fan speeds go beyond predefined thresholds.

1-6 ACPI Features

ACPI stands for Advanced Configuration and Power Interface. The ACPI specification defines a flexible and abstract hardware interface that provides a standard way to integrate power management features throughout a PC system, including its hardware, operating system and application software. This enables the system to automatically turn on and off peripherals such as CD-ROMs, network cards, hard disk drives and printers.

In addition to enabling operating system-directed power management, ACPI also provides a generic system event mechanism for Plug and Play, and an operating system-independent interface for configuration control. ACPI leverages the Plug and Play BIOS data structures, while providing a processor architecture-independent implementation that is compatible with Windows 7, Windows 8, and Windows 2008 Operating Systems.

Slow Blinking LED for Suspend-State Indicator

When the CPU goes into a suspend state, the chassis power LED will start to blink to indicate that the CPU is in suspend mode. When the user presses any key, the CPU will "wake up", and the LED will automatically stop blinking and remain on.

1-7 Power Supply

As with all computer products, a stable power source is necessary for proper and reliable operation. It is even more important for processors that have high CPU clock rates.

This motherboard accommodates 24-pin ATX power supplies. Although most power supplies generally meet the specifications required by the CPU, some are inadequate. In addition, the 12V 8-pin power connector located at JPW2 is also required to ensure adequate power supply to the system. Also your power supply must supply 1.5A for the Ethernet ports.

! Attention! To prevent damage to the power supply or motherboard, please use a power supply that contains a 24-pin and a 8-pin power connectors. Be sure to connect these connectors to the 24-pin (JPW1) and the 8-pin (JPW2) power connectors on the motherboard.

It is strongly recommended that you use a high quality power supply that meets ATX power supply Specification 2.02 or above. It must also be SSI compliant. (For more information, please refer to the website at <http://www.ssiforum.org/>). Additionally, in areas where noisy power transmission is present, you may choose to install a line filter to shield the computer from noise. It is recommended that you also install a power surge protector to help avoid problems caused by power surges.

1-8 Super I/O

The Super I/O supports two high-speed, 16550 compatible serial communication ports (UARTs). Each UART includes a 16-byte send/receive FIFO, a programmable baud rate generator, complete modem control capability and a processor interrupt system. Both UARTs provide legacy speed with baud rate of up to 115.2 Kbps as well as an advanced speed with baud rates of 250 K, 500 K, or 1 Mb/s, which support higher speed modems.

The Super I/O provides functions that comply with ACPI (Advanced Configuration and Power Interface), which includes support of legacy and ACPI power management through an SMI or SCI function pin. It also features auto power management to reduce power consumption.

C7B250-CB-ML Motherboard Image

Note: All graphics shown in this manual were based upon the latest PCB Revision available at the time of publishing of the manual. The motherboard you've received may or may not look exactly the same as the graphics shown in this manual.

C7B250-CB-ML Block Diagram

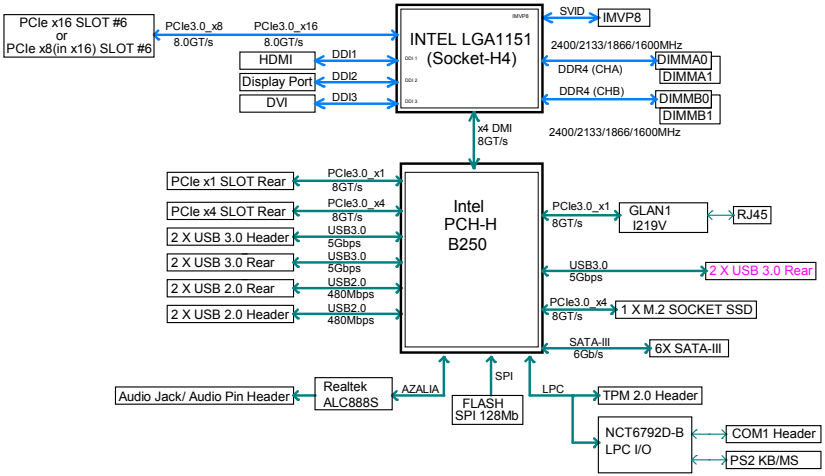

C7B250-CB-ML Quick Reference

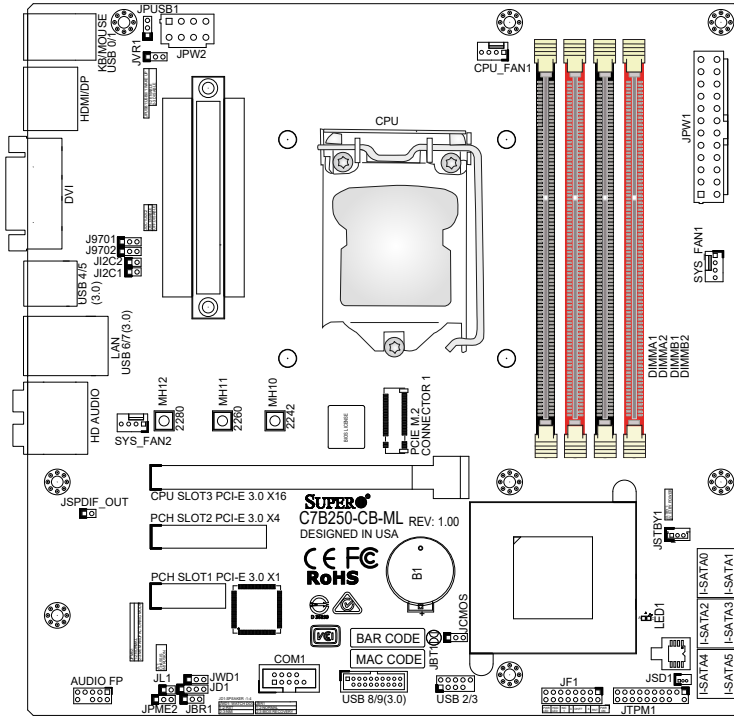

Jumper	Description	Default
JBR1	BIOS Recovery	Pins 1-2: Normal
JBT1	Clear CMOS (onboard)	Short pads to clear CMOS
JCMOS	Clear CMOS	Pins 1-2: Normal
J12C1/J12C2	SMB to PCI-E Slots	On: Enable
JPME2	Intel Manufacturing Mode	Pins 1-2: Normal
JPUSB1	USB Wake Up Enable (Back Panel USB 0/1)	Pins 1-2: Enable
JWD1	Watch Dog Function Enable	Pins 1-2: RST

Connector	Description
AUDIO FP	Front Panel Audio Header
BT1	Onboard Battery
COM1	COM1 Header
CPU_FAN1	CPU Fan Header
DVI	Digital Video Interface Port
HD AUDIO	Back Panel HD Audio Ports
HDMI/DP	High Definition Multimedia Interface/DisplayPort
I-SATA0~5	Intel PCH Serial ATA (SATA) 3.0 Ports 0~5 (6Gb/sec)
JD1	Pins 1~4: External Speaker
JF1	Front Control Panel Header
JL1	Chassis Intrusion Header
JPW1	24-pin ATX Power Connector (Required)
JPW2	8-pin CPU Power Connector (Required)
JSD1	SATA DOM (Disk On Module) Power Connector
JSPDIF_OUT	Sony/Philips Digital Interface (S/PDIF) Out Header
JSTBY1	Standby Power Header
JTPM1	Trusted Platform Module (TPM)/Port 80 Connector
KB/MOUSE	Keyboard/Mouse
LAN	RJ45 Gigabit Ethernet Port
PCI-E M.2 CONNECTOR 1	PCI-E M.2 Connector 1. Small form factor devices and other portable devices for high speed NVMe SSDs
SYS_FAN1/SYS_FAN2	System Fan Headers
USB 0/1	Back Panel USB 2.0 Ports
USB 2/3	Front Panel Accessible USB 2.0 Header
USB 4/5, USB 6/7	Back Panel USB 3.0 Ports
USB 8/9	Front Panel Accessible USB 3.0 Header

LED	Description	Color/State	Status
LED1	Power On S3 (Suspend to RAM) LED	Power On: Green On S3: Green Blinking	See page 2-31

Notes

Chapter 2

Installation

2-1 Installation Components and Tools Needed

Screws

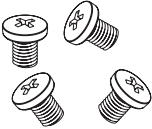

Phillips-Head Screwdriver

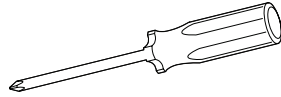

Intel LGA 1151 Processor

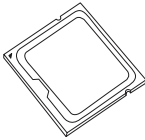

DDR4 DIMMs

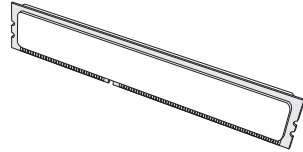

PC Chassis



Heatsink with Fan

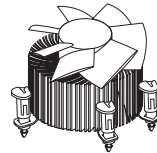

Power Supply

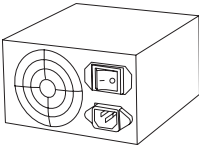

Video Card (Optional)

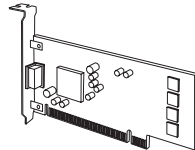

SATA/USB Optical Drive (Optional)

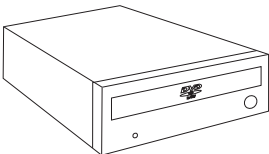

SATA Hard Disk Drive

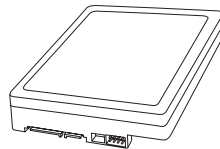

2-2 Static-Sensitive Devices

Electrostatic-Discharge (ESD) can damage electronic components. To avoid damaging your system board, it is important to handle it very carefully. The following measures are generally sufficient to protect your equipment from ESD.

Precautions

- Use a grounded wrist strap designed to prevent static discharge.
- Touch a grounded metal object before removing the board from the antistatic bag.
- Handle the board by its edges only; do not touch its components, peripheral chips, memory modules or gold contacts.
- When handling chips or modules, avoid touching their pins.
- Put the motherboard and peripherals back into their antistatic bags when not in use.
- For grounding purposes, make sure your computer chassis provides excellent conductivity between the power supply, the case, the mounting fasteners and the motherboard.
- Use only the correct type of onboard CMOS battery. Do not install the onboard battery upside down to avoid possible explosion.

Unpacking

The motherboard is shipped in antistatic packaging to avoid static damage. When unpacking the board, make sure that the person handling it is static protected.

2-3 Processor and Heatsink Installation

! **Attention!** When handling the processor package, avoid placing direct pressure on the label area of the fan.



Important:

Always connect the power cord last, and always remove it before adding, removing or changing any hardware components. Make sure that you install the processor into the CPU socket before you install the CPU heatsink.

If you buy a CPU separately, make sure that you use an Intel-certified multi-directional heatsink only.

Make sure to install the system board into the chassis before you install the CPU heatsink.

When receiving a server board without a processor pre-installed, make sure that the plastic CPU socket cap is in place and none of the socket pins are bent; otherwise, contact your retailer immediately.

Refer to the Supermicro website for updates on CPU support.

Installing the LGA1151 Processor

1. Press the load lever to release the load plate, which covers the CPU socket, from its locking position.

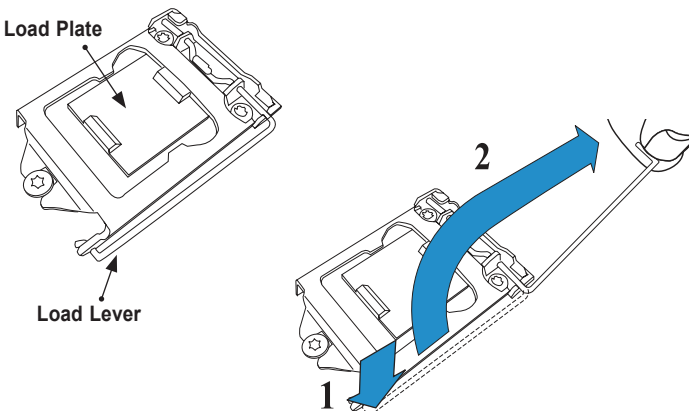

2. Gently lift the load lever to open the load plate. Remove the plastic cap.

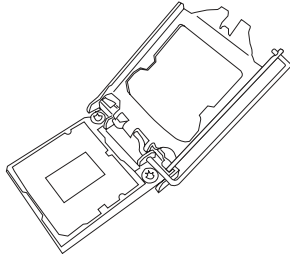

3. Use your thumb and your index finger to hold the CPU at the North center edge and the South center edge of the CPU.

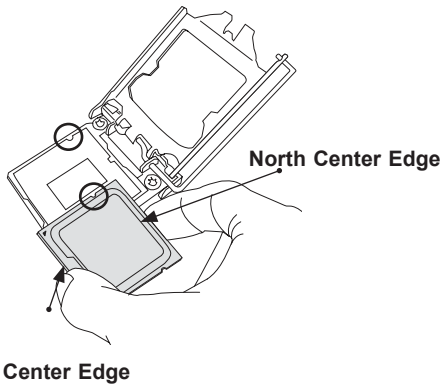

4. Align the CPU key that is the semi-circle cutouts against the socket keys. Once it is aligned, carefully lower the CPU straight down into the socket. Do not drop the CPU on the socket. Do not move the CPU horizontally or vertically.

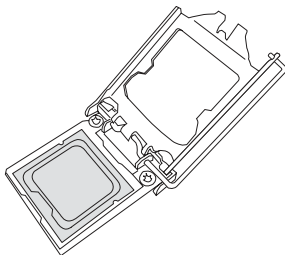

5. Do not rub the CPU against the surface or against any pins of the socket to avoid damaging the CPU or the socket.

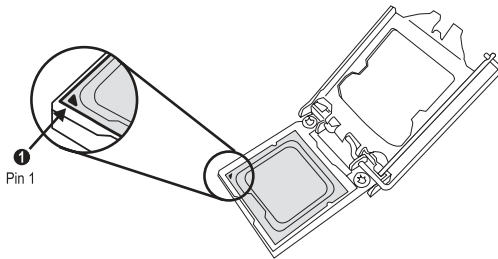

6. With the CPU inside the socket, inspect the four corners of the CPU to make sure that the CPU is properly installed.
7. Use your thumb to gently push the load lever down to the lever lock.

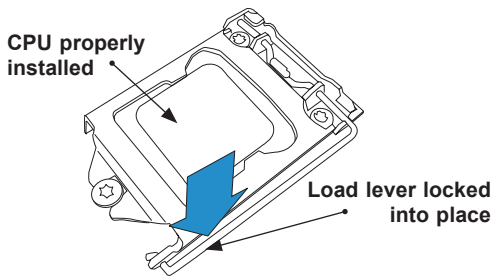

! Attention! You can only install the CPU inside the socket only in one direction. Make sure that it is properly inserted into the CPU socket before closing the load plate. If it doesn't close properly, do not force it as it may damage your CPU. Instead, open the load plate again and double-check that the CPU is aligned properly.

Installing an Active CPU Heatsink with Fan

1. Locate the CPU Fan power connector on the motherboard.
2. Position the heatsink so that its fan wires are closest to the CPU fan power connector and are not interfered with other components.
3. Inspect the CPU fan wires to make sure that the wires are routed through the bottom of the heatsink.
4. Remove the thin layer of the protective film from the heat-sink.

! Attention! CPU overheating may occur if the protective film is not removed from the heatsink.

5. Apply the proper amount of thermal grease on the CPU.

Note: if your heatsink came with a thermal pad, please ignore this step.

6. If necessary, rearrange the wires to make sure that the wires are not pinched between the heatsink and the CPU. Also make sure to keep clearance between the fan wires and the fans of the heatsink.

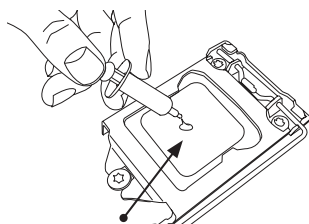

Thermal Grease

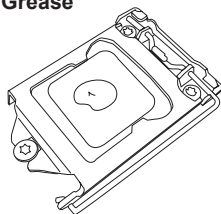

Heatsink Fans

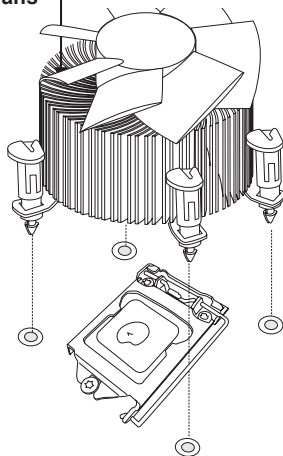

**Recommended Supermicro heatsink:
SNK-P0046A4 active heatsink**

- 7. Align the four heatsink fasteners with the mounting holes on the motherboard. Gently push the pairs of diagonal fasteners (#1 & #2, and #3 & #4) into the mounting holes until you hear a click. Also, make sure to orient each fastener so that the narrow end of the groove is pointing outward.

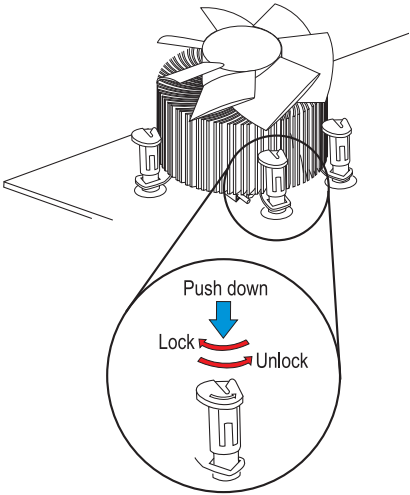

- 8. Repeat Step 7 to insert all four heatsink fasteners into the mounting holes.
- 9. Once all four fasteners are securely inserted into the mounting holes, and the heatsink is properly installed on the motherboard, connect the heatsink fan wires to the CPU fan connector.

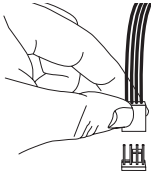

Removing the Heatsink

! Attention! We do not recommend that the CPU or the heatsink be removed. However, if you do need to remove the heatsink, please follow the instructions below to remove the heatsink and to prevent damage done to the CPU or other components.

Active Heatsink Removal

1. Unplug the power cord from the power supply.
2. Disconnect the heatsink fan wires from the CPU fan header.
3. Use your finger tips to gently press on the fastener cap and turn it counterclockwise to make a 1/4 (90°) turn, and pull the fastener upward to loosen it.
4. Repeat step 3 to loosen all fasteners from the mounting holes.
5. With all fasteners loosened, remove the heatsink from the CPU.

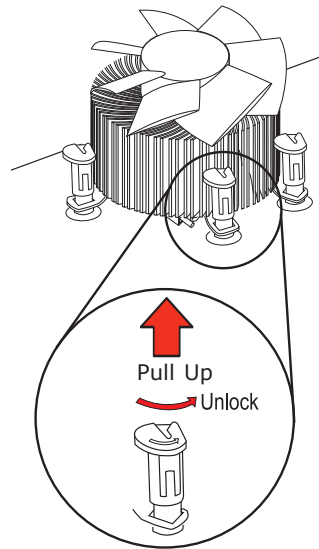
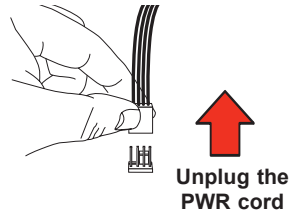

2-4 Installing DDR4 Memory



Note: Check the Supermicro website for recommended memory modules.



Attention! Exercise extreme care when installing or removing DIMM modules to prevent any possible damage.

DIMM Installation

1. Insert the desired number of DIMMs into the memory slots, starting with DIMMB2 (refer to the next page for the location). For the system to work properly, please use the memory modules of the same type and speed.
2. Align the DIMM module key with the receptive point on the single-latch DIMM slot.
3. Push the release tab outwards to unlock the slot.
4. Align the notch on the end of the module against the receptive point on the end of the slot.
5. Press both ends of the module straight down into the slot until the module snaps into place.
6. Push the release tab to the lock position to secure the module into the slot.

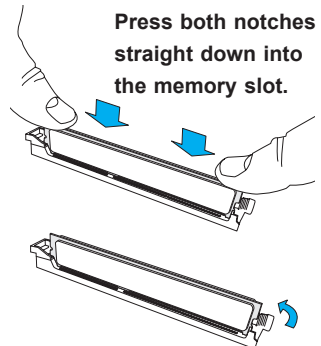
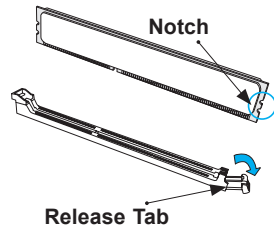
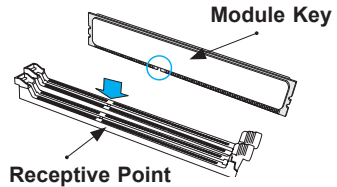
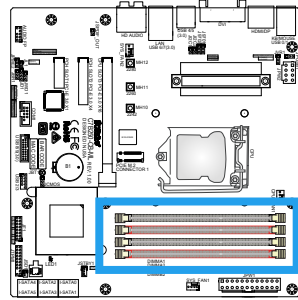

Removing Memory Modules

Reverse the steps above to remove the DIMM modules from the motherboard.

Memory Support

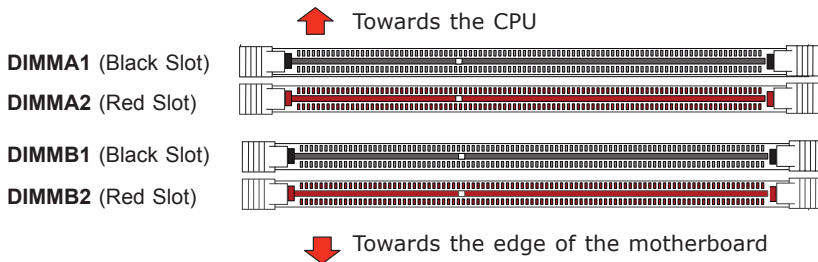

The C7B250-CB-ML supports up to 64GB of Unbuffered (UDIMM) non-ECC DDR4 memory, up to 2400MHz in four 288-pin memory slots. Populating these DIMM modules with a pair of memory modules of the same type and size will result in interleaved memory, which will improve memory performance.



Notes:

Be sure to use memory modules of the same type, speed, and frequency on the motherboard. Mixing of memory modules of different types and speeds is not allowed.

Due to memory allocation to system devices, the amount of memory that remains available for operational use will be reduced when 4 GB of RAM is used. The reduction in memory availability is disproportional. Refer to the following table for details.

Possible System Memory Allocation & Availability		
System Device	Size	Physical Memory Remaining (-Available) (4 GB Total System Memory)
Firmware Hub flash memory (System BIOS)	1 MB	3.99
Local APIC	4 KB	3.99
Area Reserved for the chipset	2 MB	3.99
I/O APIC (4 Kbytes)	4 KB	3.99
PCI Enumeration Area 1	256 MB	3.76
PCI Express (256 MB)	256 MB	3.51
PCI Enumeration Area 2 (if needed) -Aligned on 256-MB boundary-	512 MB	3.01
VGA Memory	16 MB	2.85
TSEG	1 MB	2.84
Memory available to OS and other applications		2.84

Memory Population Guidelines

When installing memory modules, the DIMM slots should be populated in the following order: DIMMB2, DIMMA2, then DIMMA1, DIMMB1.

- Always use DDR4 DIMM modules of the same size, type, and speed.
- Mixed DIMM speeds can be installed. However, all DIMMs will run at the speed of the slowest DIMM.

Recommended Population (Balanced)				
DIMMB2	DIMMA2	DIMMB1	DIMMA1	Total System Memory
4GB	4GB			8GB
4GB	4GB	4GB	4GB	16GB
8GB	8GB			16GB
8GB	8GB	8GB	8GB	32GB
16GB	16GB			32GB
16GB	16GB	16GB	16GB	64GB

2-5 Motherboard Installation

All motherboards have standard mounting holes to fit different types of chassis. Make sure that the locations of all the mounting holes for both motherboard and chassis match. Although a chassis may have both plastic and metal mounting fasteners, metal ones are highly recommended because they ground the motherboard to the chassis. Make sure that the metal standoffs click in or are screwed in tightly. Then use a screwdriver to secure the motherboard onto the motherboard tray.



Philips Screwdriver (1)



Philips Screws (8)



Standoffs (8)
Only if Needed

Tools Needed

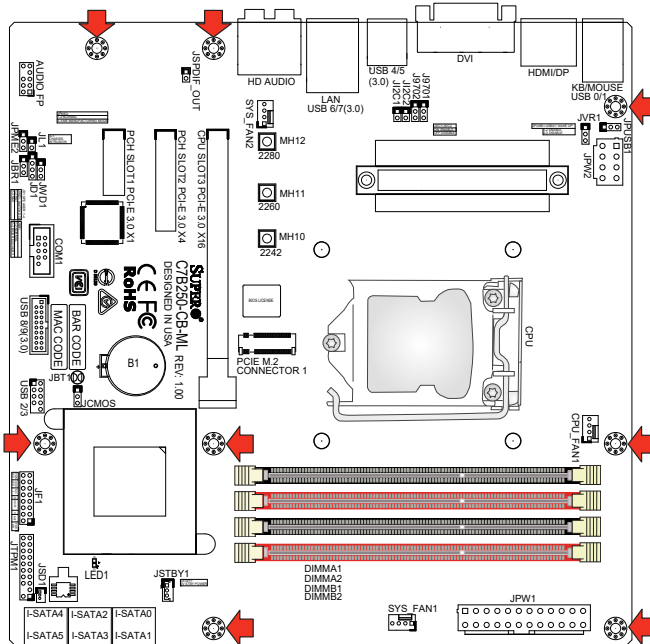

Location of Mounting Holes

- Attention!** 1) To avoid damaging the motherboard and its components, please do not use a force greater than 8 lb/inch on each mounting screw during motherboard installation. 2) Some components are very close to the mounting holes. Please take precautionary measures to avoid damaging these components when installing the motherboard to the chassis.

Installing the Motherboard

1. Install the I/O shield into the back of the chassis.

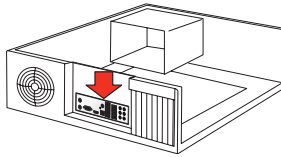

2. Locate the mounting holes on the motherboard. Refer to the previous page.
3. Locate the matching mounting holes on the chassis. Align the mounting holes on the motherboard against the mounting holes on the chassis.

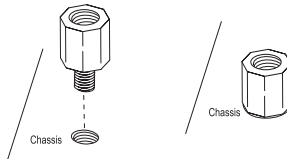

4. Install standoffs in the chassis as needed.
5. Install the motherboard into the chassis carefully to avoid damaging other motherboard components.

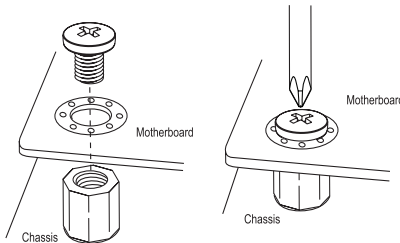

6. Using the Phillips screwdriver, insert a Phillips head #6 screw into a mounting hole on the motherboard and its matching mounting hole on the chassis.
7. Repeat Step 5 to insert #6 screws into all mounting holes.
8. Make sure that the motherboard is securely placed in the chassis.



Note: Images displayed are for illustration only. Your chassis or components might look different from those shown in this manual.

2-6 Connector and I/O Ports

The I/O ports are color coded in conformance with the industry standards. Refer to the figure below for the colors and locations of the various I/O ports.

I/O Back Panel

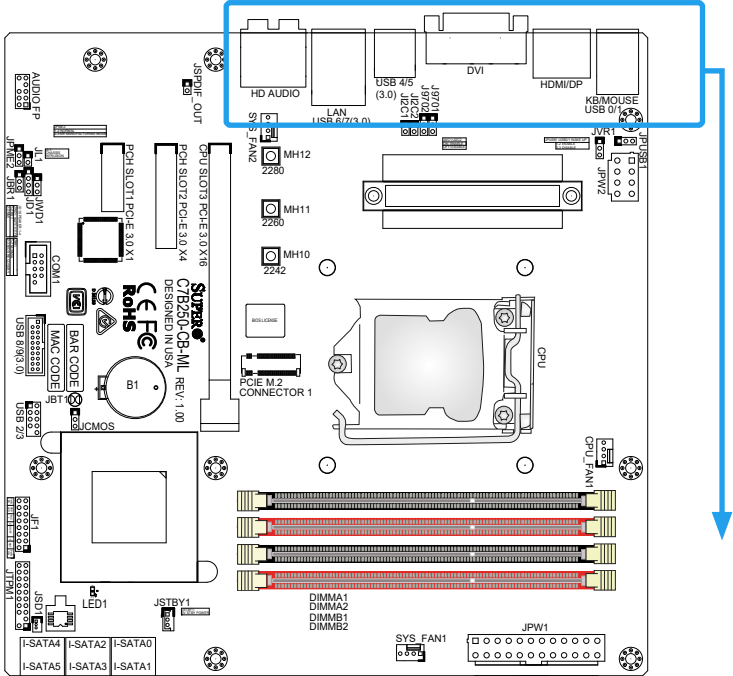

A. PS/2 Keyboard/Mouse Port	G. USB 3.0 Port 4	L. Center/LFE Out
B. USB 2.0 Port 0	H. USB 3.0 Port 5	M. Surround Out
C. USB 2.0 Port 1	I. RJ-45 Gigabit Ethernet Port	N. SPDIF Out
D. DisplayPort	J. USB 3.0 Port 6	O. Line In
E. HDMI Port	K. USB 3.0 Port 7	P. Line Out
F. DVI-D Port		Q. Mic In

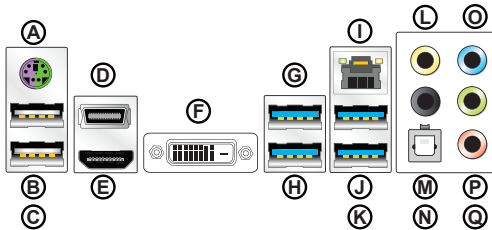

Universal Serial Bus (USB)

Four Universal Serial Bus 3.0 ports (#4, 5, 6 ,7) and two (2) USB 2.0 ports (#0, 1) are located on the I/O back panel. In addition, one USB 3.0 header (two ports: #8/9), and one USB 2.0 header (two ports: #2/3) are also located on the motherboard to provide front chassis access using USB cables (not included). Refer to the tables below for pin definitions.

Front Panel USB (2.0) Header Pin Definitions			
Pin #	Definition	Pin #	Definition
1	+5V	2	+5V
3	USB_PN2	4	USB_PN3
5	USB_PP2	6	USB_PP3
7	Ground	8	Ground
9	Key	10	Ground

Back Panel USB (2.0) , USB (3.0) Pin Definitions			
Pin#	Definition	Pin#	Definition
1	+5V	5	+5V
2	USB_PN1	6	USB_PN0
3	USB_PP1	7	USB_PP0
4	Ground	8	Ground

Front Panel USB (3.0/2.0) Pin Definitions			
Pin#	Definition	Pin#	Definition
1	VBUS	11	IntA_P2_D+
2	IntA_P1_SSRX-	12	IntA_P2_D-
3	IntA_P1_SSRX+	13	GND
4	GND	14	IntA_P2_SSTX-
5	IntA_P1_SSTX-	15	IntA_P2_SSTX+
6	IntA_P1_SSTX+	16	GND
7	GND	17	IntA_P2_SSRX+
8	IntA_P1_D-	18	IntA_P2_SSRX+
9	IntA_P1_D+	19	VBUS
10	Ground		

- A. Back Panel USB 2.0 Port 0
- B. Back Panel USB 2.0 Port 1
- C. Back Panel USB 3.0 Port 4
- D. Back Panel USB 3.0 Port 5
- E. Back Panel USB 3.0 Port 6
- F. Back Panel USB 3.0 Port 7
- G. USB 2.0 Header (USB2/3)
- H. USB 3.0 Header (USB8/9)

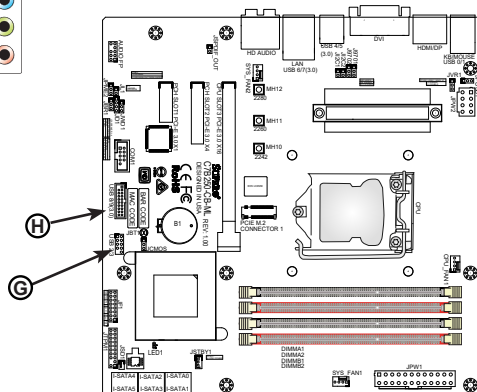
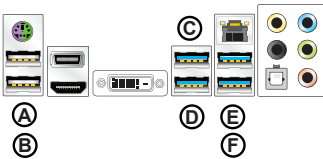

Ethernet Port

One Gigabit Ethernet port (LAN) is located next to the USB 3.0 ports on the I/O back panel to provide network connections. This port accepts RJ45 type cables.



Note: Please refer to the Section 2-9 Onboard Indicators for LAN LED information.

LAN Ports Pin Definition			
Pin#	Definition		
1	P2V5SB	10	SGND
2	TD0+	11	Act LED
3	TD0-	12	P3V3SB
4	TD1+	13	Link 100 LED (Green, +3V3SB)
5	TD1-	14	Link 1000 LED (Yellow, +3V3SB)
6	TD2+	15	Ground
7	TD2-	16	Ground
8	TD3+	17	Ground
9	TD3-	88	Ground

Back Panel High Definition Audio (HD Audio)

This motherboard features a 7.1+2 Channel High Definition Audio (HDA) codec that provides 10 DAC channels. The HD Audio connections simultaneously supports multiple-streaming 7.1 sound playback with two channels of independent stereo output through the front panel stereo out for front, rear, center and subwoofer speakers. Use the Advanced software included in the CD-ROM with your motherboard to enable this function.

Port	Headset, 2 Channels	4.1 Channels	5.1 Channels	7.1 Channels
Light Blue	Line In	Line In	Line In	Line In
Lime	Line Out	Front Speaker Out	Front Speaker Out	Front Speaker Out
Pink	Mic In	Mic In	Mic In	Mic In
Orange			Center/Subwoofer	Center/Subwoofer
Optical S/PDIF Out				Side Speaker Out
Black		Rear Speaker Out	Rear Speaker Out	Rear Speaker Out

Audio 2, 4.1, 5.1 or 7.1 channel configuration chart

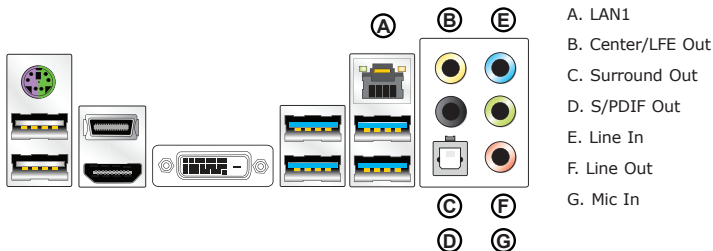

ATX PS/2 Keyboard/Mouse Port

The shared ATX PS/2 keyboard/mouse port is located above the back panel USB Ports 0/1 on the motherboard.

VESA® DisplayPort™

DisplayPort, developed by the VESA consortium, delivers digital display at a fast refresh rate. It can connect to virtually any display device using a DisplayPort adapter for devices such as VGA, DVI, or HDMI.

HDMI Port

One HDMI (High-Definition Multimedia Interface) is located on the I/O back panel. This connector is used to display both high definition video and digital sound through an HDMI capable display, using a single HDMI cable (not included).

DVI Port

A DVI (video only) port is located on the I/O back panel. Use this port to connect to a compatible DVI (Digital Visual Interface) display.

- A. PS/2 Keyboard/Mouse Port
- B. VESA DisplayPort
- C. HDMI Port
- D. DVI-D Port

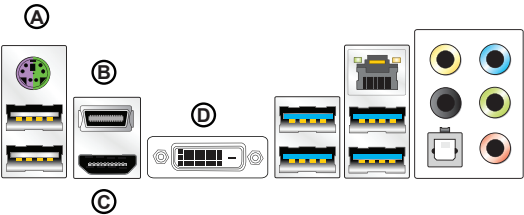

Front Control Panel

JF1 contains header pins for various buttons and indicators that are normally located on a control panel at the front of the chassis. These connectors are designed specifically for use with Supermicro chassis. Refer to the figure below for the descriptions of the front control panel buttons and LED indicators. Refer to the following section for descriptions and pin definitions.

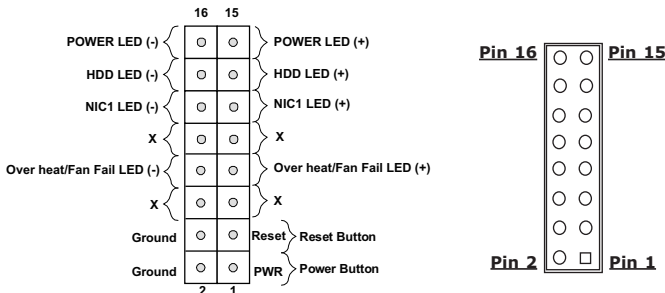
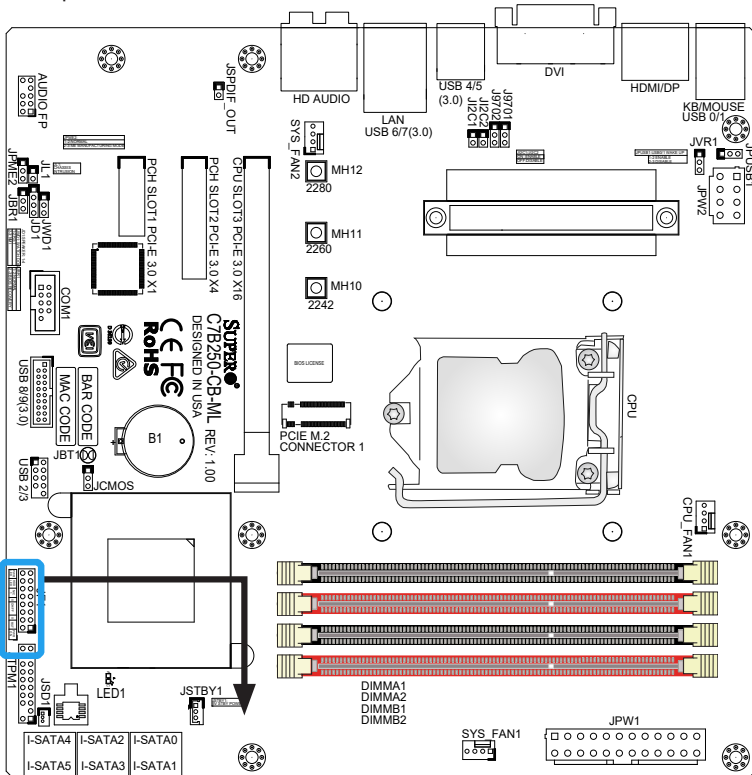

JF1 Header Pins

Front Control Panel Pin Definitions

Power LED

The Power LED connection is located on pins 15 and 16 of JF1. Refer to the table on the right for pin definitions.

Power LED Pin Definitions (JF1)	
Pin#	Definition
15	+5V
16	Ground

HDD LED

The HDD LED connection is located on pins 13 and 14 of JF1. Attach a cable here to indicate the status of HDD-related activities, including IDE, SATA activities. Refer to the table on the right for pin definitions.

HDD LED Pin Definitions (JF1)	
Pin#	Definition
13	+5V
14	HD Active

NIC1 (LAN)

The NIC (Network Interface Controller) LED connection for LAN port 1 is located on pins 11 and 12 of JF1. Attach an LED indicator to this header to display network activity. Refer to the table on the right for pin definitions.

LAN LED Pin Definitions (JF1)	
Pin#	Definition
11	Vcc
12	Ground

Overheat (OH)/Fan Fail

Connect an LED cable to OH/Fan Fail connections on pins 7 and 8 of JF1 to provide warnings for chassis overheat/fan failure. Refer to the table on the right for pin definitions.

OH/Fan Fail LED Pin Definitions (JF1)	
Pin#	Definition
7	Vcc/Blue UID LED
8	OH/Fan Fail LED

OH/Fan Fail Indicator Status	
State	Definition
Off	Normal
On	Overheat
Flashing	Fan Fail

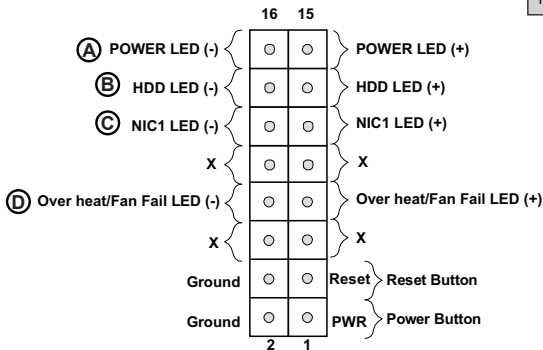

- A. PWR LED
- B. HDD LED
- C. NIC1 LED
- D. OH/Fan Fail

Reset Button

The Reset Button connection is located on pins 3 and 4 of JF1. Attach it to a hardware reset switch on the computer case to reset the system. Refer to the table on the right for pin definitions.

Reset Button Pin Definitions (JF1)	
Pin#	Definition
3	Reset
4	Ground

Power Button

The Power Button connection is located on pins 1 and 2 of JF1. Momentarily contacting both pins will power on/off the system. This button can also be configured to function as a suspend button (with a setting in the BIOS - refer to Chapter 4 BIOS). To turn off the power in the suspend mode, press the button for at least 4 seconds. Refer to the table on the right for pin definitions.

Power Button Pin Definitions (JF1)	
Pin#	Definition
1	PWRBTN
2	GND

- A. Reset Button
- B. PWR Button

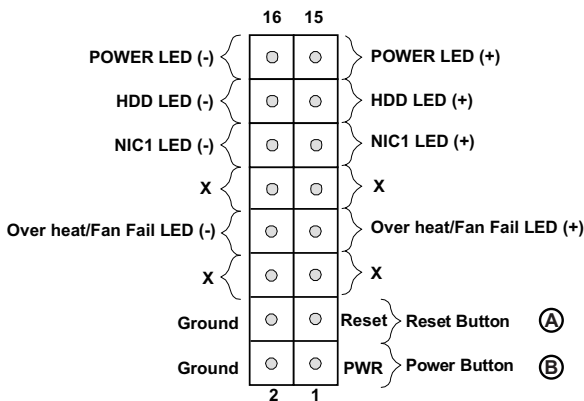

2-7 Connecting Cables

This section provides brief descriptions and pinout definitions for onboard headers and connectors. Be sure to use the correct cable for each header or connector.

ATX Main PWR & CPU PWR Connectors

The 24-pin main power connector (JPW1) is used to provide power to the motherboard. The 8-pin CPU PWR connector (JPW2) is also required for the processor. These power connectors meet the SSI EPS 12V specification. Refer to the table on the right for pin definitions.

ATX Power 24-pin Connector Pin Definitions (JPW1)			
Pin#	Definition	Pin #	Definition
13	+3.3V	1	+3.3V
14	-12V	2	+3.3V
15	COM	3	COM
16	PS_ON	4	+5V
17	COM	5	COM
18	COM	6	+5V
19	COM	7	COM
20	Res (NC)	8	PWR_OK
21	+5V	9	5VSB
22	+5V	10	+12V
23	+5V	11	+12V
24	COM	12	+3.3V

12V 8-pin Power Connector Pin Definitions	
Pins	Definition
1 through 4	Ground
5 through 8	+12V

(Required)

A. 24-Pin ATX Main PWR

B. 8-Pin PWR

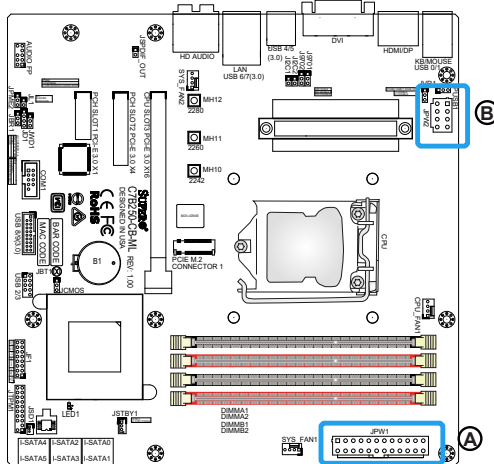

Fan Headers

Your motherboard has three fan headers (SYS_FAN 1~2, CPU_FAN1). These fans are 4-pin fan headers. Although pins 1-3 of the fan headers (SYS_FAN 1~2) are backward compatible with the traditional 3-pin fans, we recommend the use 4-pin fans to take advantage of the fan speed control. This allows the fan speeds to be automatically adjusted based on the motherboard temperature. Refer to the table on the right for pin definitions.

Fan Header Pin Definitions	
Pin#	Definition
1	Ground (Black)
2	2.5A/+12V (Red)
3	Tachometer
4	PWM_Control

Chassis Intrusion

A Chassis Intrusion header is located at JL1 on the motherboard. Attach the appropriate cable from the chassis to inform you of a chassis intrusion when the chassis is opened.

Chassis Intrusion Pin Definitions (JL1)	
Pin#	Definition
1	Intrusion Input
2	Ground

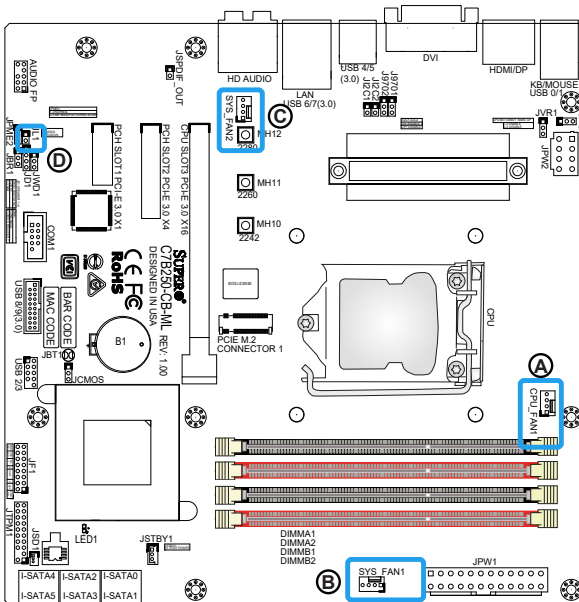

- A. CPU Fan Header
- B. System Fan Header 1
- C. System Fan Header 2
- D. Chassis Intrusion

COM Connection

There is one COM header on the motherboard. Refer to the table on the right for pin definitions.

Serial/COM Header Pin Definitions			
Pin#	Definition	Pin#	Definition
1	DCD	6	DSR
2	RXD	7	RTS
3	TXD	8	CTS
4	DTR	9	RI
5	Ground	10	N/A

Speaker

If you wish to use an external speaker, close pins 1~4 with a cable. Refer to the table on the right for pin definitions.

Speaker Connector Pin Definitions	
Pin Setting	Definition
Pins1~4	External Speaker

A. COM1

B. Speaker Header

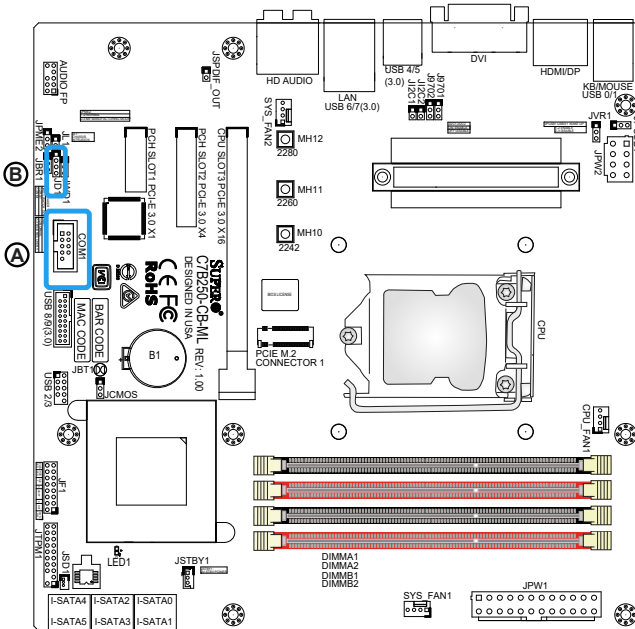

Front Panel Audio Header (AUDIO FP)

A 10-pin Audio header is supported on the motherboard. This header allows you to connect the motherboard to a front control audio panel, if needed. Connect an audio cable to the audio header to use this feature (not supplied). Refer to the table on the right for pin definitions for the header.

10-in Audio Pin Definitions	
Pin#	Signal
1	Microphone_Left
2	Audio_Ground
3	Microphone_Right
4	Audio_Detect
5	Line_2_Right
6	Ground
7	Jack_Detect
8	Key
9	Line_2_Left
10	Ground

TPM Header/Port 80

A Trusted Platform Module/Port 80 header is located at JTPM1 to provide TPM support and Port 80 connection. Use this header to enhance system performance and data security. Refer to the table on the right for pin definitions.

TPM/Port 80 Header Pin Definitions			
Pin #	Definition	Pin #	Definition
1	LCLK	2	GND
3	LFRAME#	4	<(KEY)>
5	LRESET#	6	+5V (X)
7	LAD 3	8	LAD 2
9	+3.3V	10	LAD1
11	LAD0	12	GND
13	SMB_CLK4	14	SMB_DAT4
15	+3V_DUAL	16	SERIRQ
17	GND	18	CLKRUN# (X)
19	LPCPD#	20	LDRQ# (X)

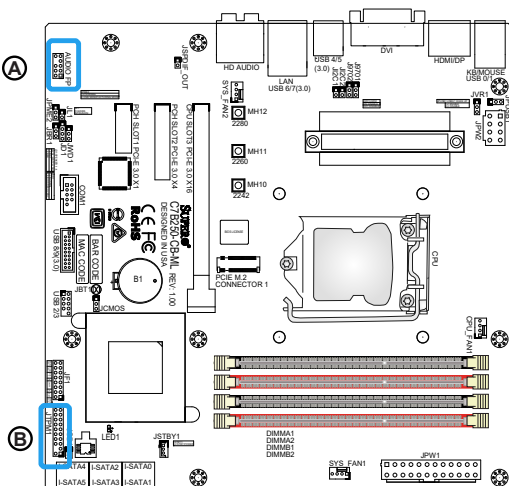

- A. AUDIO FP
- B. TPM Header

2-8 Jumper Settings

Explanation of Jumpers

To modify the operation of the motherboard, jumpers can be used to choose between optional settings. Jumpers create shorts between two pins to change the function of the connector. Pin 1 is identified with a square solder pad on the printed circuit board.



Note: On two-pin jumpers, "Closed" means the jumper is on, and "Open" means the jumper is off the pins.

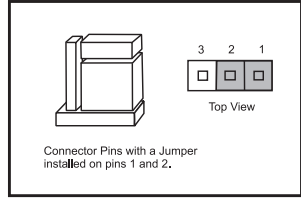
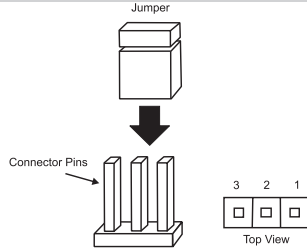

Manufacturing Mode

Close pins 2-3 of JPME2 to bypass SPI flash security and force the system to operate in Manufacturing Mode, allowing the user to flash the system firmware from a host server for system setting modifications. Refer to the table on the right for jumper settings.

Manufacture Mode (JPME2) Jumper Settings	
Pin#	Definition
1-2	Normal (Default)
2-3	Manufacture Mode

A. Manufacturing Mode

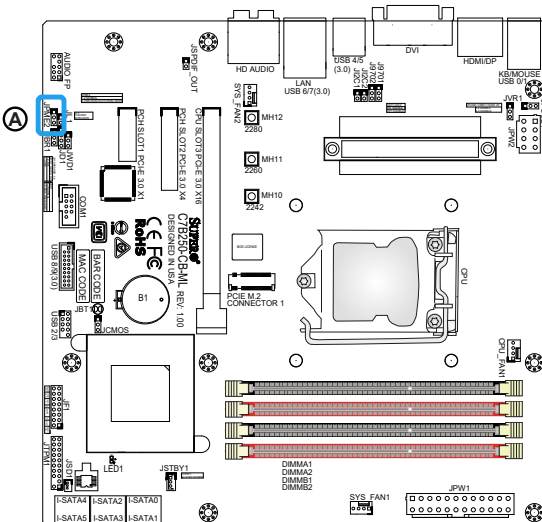

Watch Dog Timer Enable/Disable

Watch Dog (JWD1) is a system monitor that can reboot the system when a software application hangs. Close pins 1-2 to reset the system if an application hangs. Close pins 2-3 to generate a non-maskable interrupt signal for the application that hangs. Refer to the table on the right for jumper settings.

Watch Dog Jumper Settings	
Jumper Setting	Definition
Pins 1-2	Reset (default)
Pins 2-3	NMI
Open	Disabled

BIOS Recovery Jumper

The BIOS Recovery Jumper (JBR1) is a slide switch that is used to enable or disable the BIOS Recovery feature of the motherboard. Refer to Appendix D for details.

BIOS Recovery (JBR1) Switch Settings	
State	Definition
Pin 1-2	Normal (Default)
Pin 2-3	BIOS Recovery

- A. Watch Dog Timer
- B. BIOS Recovery Switch

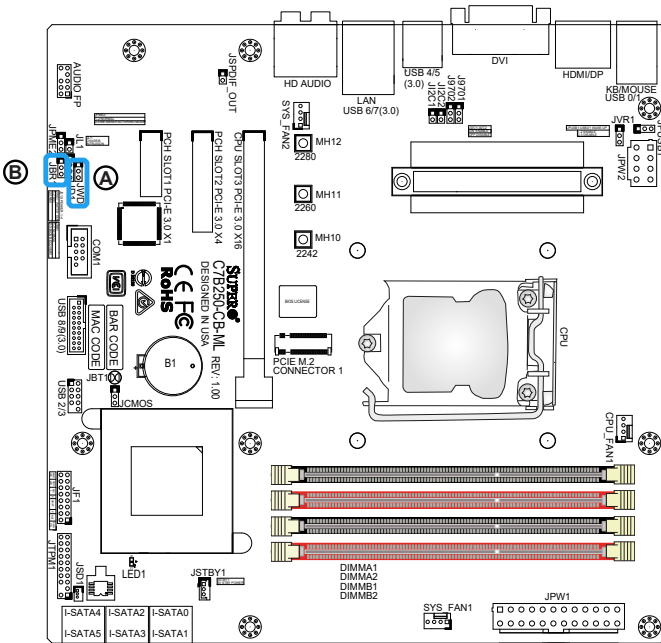

USB Wake Up

Use jumper JUSB to activate the "wake up" function of the USB ports by pressing a key on a USB keyboard or clicking the USB mouse connected. This jumper is used together with a USB Wake Up feature in the BIOS. Enable this jumper and the USB support in the BIOS to wake up your system via USB devices.

USB Wake Up Jumper Settings	
Jumper Setting	Definition
Pins 1-2	Enabled
Pins 2-3	Disabled (Default)

A. USB Wake Up

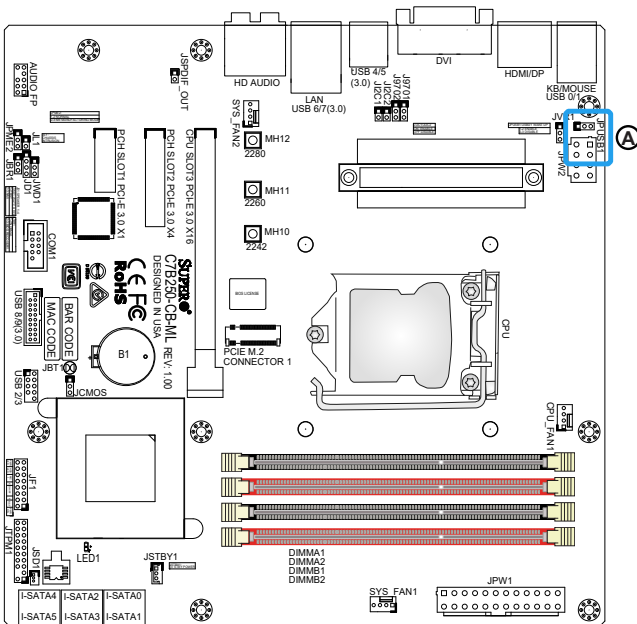

2-9 Onboard Indicators

LAN LEDs

One LAN port is located on the I/O back panel of the motherboard. This Ethernet LAN port has two LEDs (Light Emitting Diode). The yellow LED indicates activity, while the Link LED may be green, amber, or off to indicate the speed of the connections. Refer to the tables at right for more information.

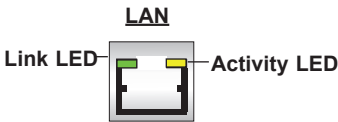

GLAN Activity Indicator LED Settings		
Color	Status	Definition
Yellow	Flashing	Active

GLAN Link Indicator LED Settings	
LED Color	Definition
Off	No Connection/10 Mbps/100 Mbps
Amber	1 Gbps
Green	10 Gbps

Onboard Power LED

An Onboard Power LED is located at LED1 on the motherboard. When LED1 is on, the AC power cable is connected and the system is on. When LED1 is blinking, it is in Stand By (S3, Suspend to RAM).

Onboard PWR LED Indicator LED Status	
Status	Definition
Off	System Off
On	System On
Blinking	S3, Suspend to RAM

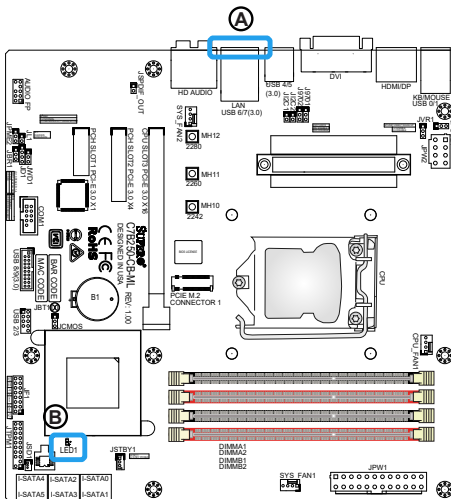

- A. LAN LEDs
- B. PWR LED

2-10 Hard Drive Connections

SATA Connections (I-SATA0~I-SATA5)

Six SATA 3.0 connectors (I-SATA 0~5) are supported on the motherboard. Refer to the table on the right for pin definitions.

SATA 2.0/3.0 Connectors Pin Definitions	
Pin#	Signal
1	Ground
2	SATA_TXP
3	SATA_TXN
4	Ground
5	SATA_RXN
6	SATA_RXP
7	Ground

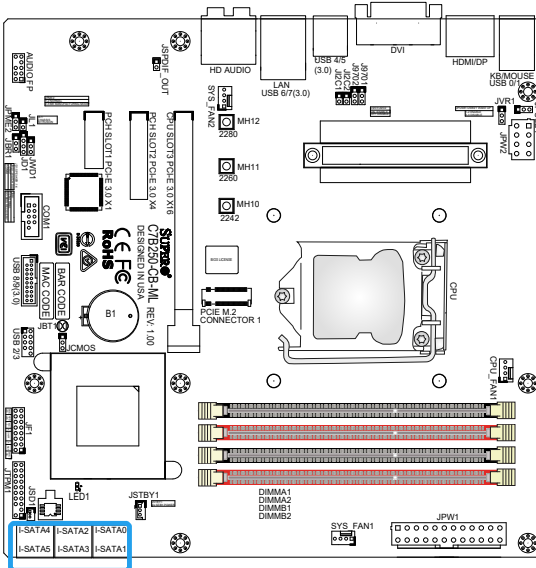

Top

- A. I-SATA 3.0 #4
- B. I-SATA 3.0 #2
- C. I-SATA 3.0 #0

Bottom

- D. I-SATA 3.0 #5
- E. I-SATA 3.0 #3
- F. I-SATA 3.0 #1

- (A) (B) (C) (Top)
- (D) (E) (F) (Bottom)

Chapter 3

Troubleshooting

3-1 Troubleshooting Procedures

Use the following procedures to troubleshoot your system. If you have followed all of the procedures below and still need assistance, refer to the 'Technical Support Procedures' and/or 'Returning Merchandise for Service' section(s) in this chapter. Always disconnect the AC power cord before adding, changing or installing any hardware components.

Before Power On

1. Make sure that the Standby PWR LED is not on. (**Note:** If it is on, the onboard power is on. Be sure to unplug the power cable before installing or removing the components.)
2. Make sure that there are no short circuits between the motherboard and chassis.
3. Disconnect all ribbon/wire cables from the motherboard, including those for the keyboard and mouse. Also, be sure to remove all add-on cards.
4. Install a CPU and heatsink (be sure that it is fully seated) and then connect the chassis speaker and the power LED to the motherboard. Check all jumper settings as well.

No Power

1. Make sure that there are no short circuits between the motherboard and chassis.
2. Make sure that all jumpers are set to their default positions.
3. Check if the 115V/230V switch on the power supply is properly set.
4. Turn the power switch on and off to test the system.

5. The battery on your motherboard may be old. Check to make sure that it still supplies ~3VDC. If it does not, replace it with a new one.

No Video

1. If the power is on, but you have no video--in this case, you will need to remove all the add-on cards and cables first.
2. Use the speaker to determine if any beep codes exist. (Refer to Appendix A for details on beep codes.)
3. Remove all memory modules and turn on the system. (If the alarm is on, check the specifications of memory modules, reset the memory or try a different one.)

Memory Errors

1. Make sure that the DIMM modules are properly installed and fully seated in the slots.
2. You should be using unbuffered Non-ECC DDR4 (up to 2400) MHz memory recommended by the manufacturer. Also, it is recommended that you use the memory modules of the same type and speed for all DIMMs in the system. Do not use memory modules of different sizes, different speeds and different types on the same motherboard.
3. Check for bad DIMM modules or slots by swapping modules between slots to see if you can locate the faulty ones.
4. Check the switch of 115V/230V power supply.

When the System is Losing the Setup Configuration

1. Please be sure to use a high quality power supply. A poor quality power supply may cause the system to lose CMOS setup information. Refer to Section 1-5 for details on recommended power supplies.
2. The battery on your motherboard may be old. Check to verify that it still supplies ~3VDC. If it does not, replace it with a new one.

3. If the above steps do not fix the Setup Configuration problem, contact your vendor for repairs.

3-2 Technical Support Procedures

Before contacting Technical Support, please make sure that you have followed all the steps listed below. Also, Note that as a motherboard manufacturer, Supermicro does not sell directly to end users, so it is best to first check with your distributor or reseller for troubleshooting services. They should know of any possible problem(s) with the specific system configuration that was sold to you.

1. Please go through the 'Troubleshooting Procedures' and 'Frequently Asked Question' (FAQ) sections in this chapter or refer to the FAQs on our website (<http://www.supermicro.com/support/faqs/>) before contacting Technical Support.
2. BIOS upgrades can be downloaded from our website at (<http://www.supermicro.com/support/bios/>).



Note: Not all BIOS can be flashed. Some cannot be flashed; it depends on the boot block code of the BIOS.

3. If you've followed the instructions above to troubleshoot your system, and still cannot resolve the problem, then contact Supermicro's technical support and provide them with the following information:
 - Motherboard model and PCB revision number
 - BIOS release date/version (this can be seen on the initial display when your system first boots up)
 - System configuration
 - An example of a Technical Support form is on our website at (<http://www.supermicro.com/support/contact.cfm>).
4. Distributors: For immediate assistance, please have your account number ready when placing a call to our technical support department. We can be reached by e-mail at support@supermicro.com, by phone at: (408) 503-8000, option 2, or by fax at (408)503-8019.

3-3 Frequently Asked Questions

Question: What type of memory does my motherboard support?

Answer: The C7B250-CB-ML supports up to 64GB of unbuffered Non-ECC DDR4. Refer to Section 2-4 for details on installing memory.

Question: How do I update my BIOS?

Answer: We do NOT recommend that you upgrade your BIOS if you are not experiencing any problems with your system. Updated BIOS files are located on our website at <http://www.supermicro.com/support/bios/>. Please check our BIOS warning message and the information on how to update your BIOS on our website. Select your motherboard model and download the BIOS ROM file to your computer. Also, check the current BIOS revision to make sure that it is newer than your BIOS before downloading. You may choose the zip file or the .exe file. If you choose the zipped BIOS file, please unzip the BIOS file onto a bootable device or a USB pen/thumb drive. To flash the BIOS, run the batch file named "ami.bat" with the new BIOS ROM file from your bootable device or USB pen/thumb drive. Use the following format:

```
F:\> ami.bat BIOS-ROM-filename.xxx <Enter>
```



Note: Always use the file named "ami.bat" to update the BIOS, and insert a space between "ami.bat" and the filename. The BIOS-ROM-filename will bear the motherboard name (e.g., C7B250) and build version as the extension. For example, "C7B250.115". When completed, your system will automatically reboot.

If you choose the .exe file, please run the .exe file under Windows to create the BIOS flash disk. Insert the flash disk into the system you wish to flash the BIOS. Then, boot the system to the flash disk. The BIOS utility will automatically flash the BIOS without any prompts. Please note that this process may take a few minutes to complete. Do not be concerned if the screen is paused for a few minutes.

When the BIOS flashing screen is completed, the system will reboot and will show "Press F1 or F2". At this point, you will need to load the BIOS defaults. Press <F1> to go to the BIOS setup screen, and press <F9> to load the default settings. Next, press <F10> to save and exit. The system will then reboot.



Attention! Do not shut down or reset the system while updating the BIOS to prevent possible system boot failure!

Question: I think my BIOS is corrupted. How can I recover my BIOS?

Answer: Please refer to Appendix C-BIOS Recovery for detailed instructions.

3-4 Battery Removal and Installation

Battery Removal

To remove the onboard battery, follow the steps below:

1. Power off your system and unplug your power cable.
2. Locate the onboard battery as shown below.
3. Using a tool such as a pen or a small screwdriver, push the battery lock outwards to unlock it. Once unlocked, the battery will pop out from the holder.
4. Remove the battery.

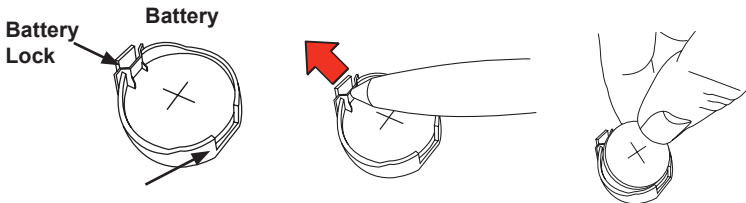

Proper Battery Disposal

! Attention! Please handle used batteries carefully. Do not damage the battery in any way; a damaged battery may release hazardous materials into the environment. Do not discard a used battery in the garbage or a public landfill. Please comply with the regulations set up by your local hazardous waste management agency to dispose of your used battery properly.

Battery Installation

1. To install an onboard battery, follow the steps 1 and 2 above and continue below:
2. Identify the battery's polarity. The positive (+) side should be facing up.
3. Insert the battery into the battery holder and push it down until you hear a click to ensure that the battery is securely locked.

! **Attention!** When replacing a battery, be sure to only replace it with the same type.

Battery Holder



This side up

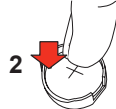
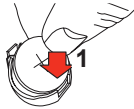

Press down until you hear a click.

3-5 Returning Motherboard for Service

A receipt or copy of your invoice marked with the date of purchase is required before any warranty service will be rendered. You can obtain service by calling your vendor for a Returned Merchandise Authorization (RMA) number. For faster service, you may also obtain RMA authorizations online (<http://www.supermicro.com/RmaForm/>). When you return the motherboard to the manufacturer, the RMA number should be prominently displayed on the outside of the shipping carton, and mailed prepaid or hand-carried. Shipping and handling charges will be applied for all orders that must be mailed when service is complete.

This warranty only covers normal consumer use and does not cover damages incurred in shipping or from failure due to the alteration, misuse, abuse or improper maintenance of products.

During the warranty period, contact your distributor first for any product problems.

Chapter 4

BIOS

4-1 Introduction

This chapter describes the BIOS Setup Utility for the C7B250-CB-ML. The BIOS is stored in a Flash EEPROM and can be easily updated. This chapter describes the basic navigation of the BIOS Setup Utility setup screens.



Note: For BIOS Recovery, please refer to the BIOS Recovery Instructions in Appendix C.

Starting BIOS GUI Setup Utility

To enter the BIOS GUI Setup Utility screens, press the <Delete> key while the system is booting up.



Note: In most cases, the <Delete> key is used to invoke the BIOS setup screen.

SUPER™ English F12

05:49:49
THU 04/05/2017

C7B250-CB-ML
VERSION T20170105113515
BIOS Build Date: 01/05/2017

CPU: Genuine Intel(R)
CPU Speed: 3700 MHz
BCLK: 99.756 MHz
VCPU: 1.152V

Memory: 4096 Mb
Memory Frequency: 2133 MHz
VDIMM: 1.252V
Temperature CPU: 45°C PCH: 32°C

Processor Information Previous

Name	Kabylake DT
Type	Genuine Intel(R) CPU 0000 @ 3.70GHz
Speed	3700 MHz
ID	0x506B
Stepping	A0
Number of Processors	4Core(s)/8Thread(s)
Microcode Revision	34
GT Information	GT2 (0x5912)
IGFX BIOS Version	1049
IGFX GOP Version	N/A
Memory RC Version	1.2.0.0

CPU Configuration

Power & Performance

CPU_FAN1	SYS_FAN1	SYS_FAN2
Sensor: CPU	Sensor: PCH	Sensor: PCH
Temperature	Temperature	Temperature
Speed: 800RPM	Speed: NA	Speed: NA

Version 1.01.0040 Copyright (C) 2017 American Megatrends, Inc.

Arrow Key: Move
Enter Key: Select
F1: Key: Value
ESC Key: Save
F10 Key: General Help

Each BIOS menu feature is described in this manual. The Main BIOS Setup screen has two main areas. The left area is the Main Navigation, and the main area is for the Information Section. Icons that do not respond when the mouse pointer is hovering on top are not configurable.

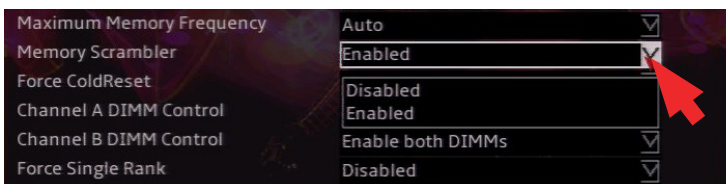

The BIOS GUI Setup Utility uses a mouse pointer navigation system similar to standard graphical user interfaces. Hover and click an icon to select a section, click a down arrow to select from an option list.

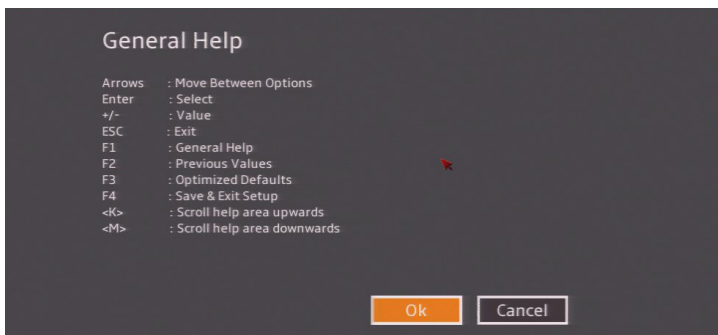

You may press the <F1> on any screen under the Setup Section to see a list of Hot Keys that are available. Press <F12> to print the screen.

The keyboard's Escape key <ESC> cancels the current screen and will you back to the previous screen.

How To Change the Configuration Data

The configuration data that determines the system parameters may be changed by entering the BIOS GUI Setup utility. This Setup utility can be accessed by pressing at the appropriate time during system boot.



Note: For the purposes of this manual, options that are printed in **Bold** are default settings.

How to Start the Setup Utility

Normally, the only visible Power-On Self-Test (POST) routine is the memory test. As the memory is being tested, press the <Delete> key to enter the main menu of the BIOS GUI Setup Utility. From the Setup Home screen, you can access the other Setup Sections.

4-2 System Information

The System Information Panel displays the motherboard's configuration.

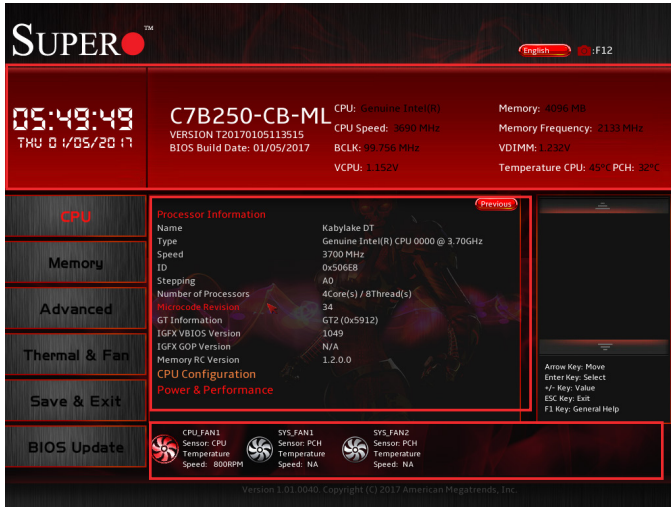

The following information among others is displayed in this section:

- **Motherboard Model Name** - C7B250-CB-ML.
- **Version** - this feature displays the BIOS version number.
- **Build Date and Time** - displays the BIOS build date and time.
- **CPU** - displays the CPU type speed, stepping, etc
- **CPU Fan Data** - displays sensor type, temperature, speed

System Date

Click on the date to open the setup fields. This feature sets and displays the system date. Click the up and down arrows to adjust the date.

System Time

Click on the time to open the setup fields. This feature sets and displays the system time. Click the up and down arrows to adjust the system time.

4-3 CPU

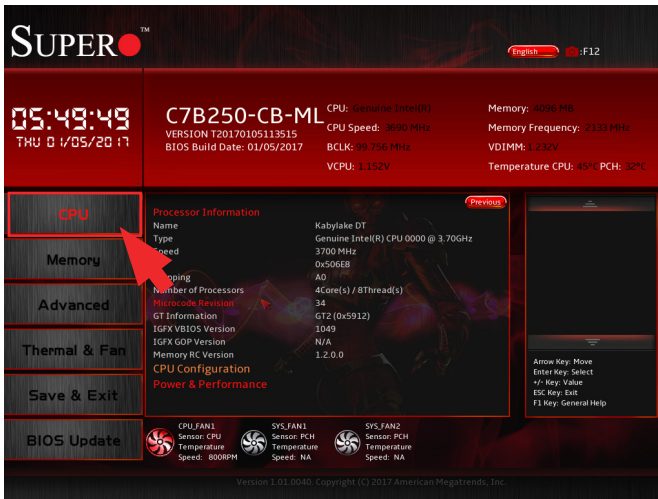

The following information is displayed in this section:

- **Name** - indicates the model name of the CPU.
- **Type** - indicates the brand, model name, model number of the CPU and its rated clock speed.
- **Speed** - this feature shows the detected CPU speed.
- **ID** - displays the unique CPU ID.
- **Stepping** - displays the processor stepping.
- **Number of Processors** - displays the number of cores detected.
- **Microcode Revision** - displays the CPU's microcode patch version.
- **GT Info** - this feature shows the processor's GT Information.
- **IGFX VBIOS Version** - this feature shows the Integrated Graphics VBIOS version.
- **IGFX GOP Version** - this feature shows the Integrated Graphics VOP version.
- **Memory RC Version** - this feature shows the memory RC version.

CPU Configuration

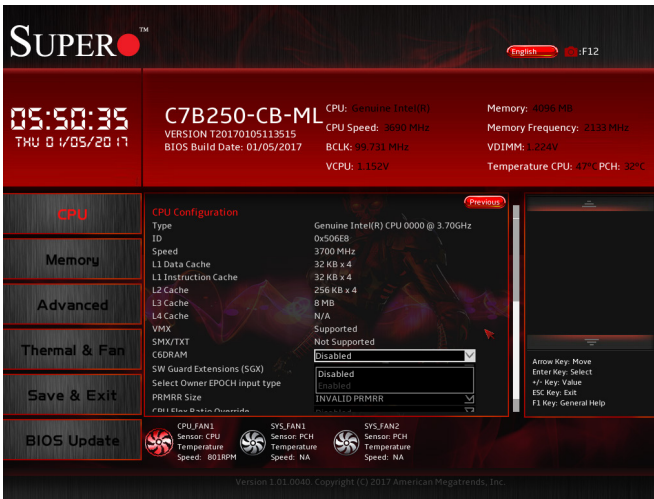

The following CPU information will be displayed:

- **CPU Type** - displays the CPU type.
- **Type** - indicates the brand, model name, model number of the CPU and its rated clock speed.
- **ID** - displays the unique CPU ID.
- **Speed** - this feature shows the detected CPU speed.
- **L1 Data Cache** - indicates if Level 1 cache is supported.
- **L1 Instruction Cache** - displays if Level 1 instruction cache is supported.
- **L2 Cache** - indicates if Level 2 cache is supported.
- **L3 Cache** - displays whether Level 3 cache is supported or not.
- **L4 Cache** - indicates if Level 4 cache is supported.
- **VMX** - indicates if VMX is supported.
- **SMX/TXT** - indicates if SMX/TXT is supported.

SW Guard Extension (SGX)

Select Enabled to activate the Software Guard Extensions (SGX). The options are Enabled, Disabled, and **Software Controlled**. Please enable this option for SGX support.

CPU Flex Ratio Override

Select Enabled to activate CPU Flex Ratio programming. The options are Enabled and **Disabled**.

CPU Flex Ratio Settings

When CPU Flex Ratio Override is enabled, this sets the value for the CPU Flex Ratio. The default is **16**.

Hardware Prefetcher

(Available when supported by the CPU)

If set to Enabled, the hardware prefetcher will prefetch streams of data and instructions from the main memory to the L2 cache to improve CPU performance. The options are Disabled and **Enabled**.

Adjacent Cache Line Prefetch

(Available when supported by the CPU)

Select Enabled for the CPU to prefetch both cache lines for 128 bytes as comprised. Select Disabled for the CPU to prefetch both cache lines for 64 bytes. The options are Disabled and **Enabled**.

Intel® (VMX) Virtualization Technology

(Available when supported by the CPU)

Select Enabled to use the Intel Virtualization Technology to allow one platform to run multiple operating systems and applications in independent partitions, creating multiple "virtual" systems in one physical computer. The options are **Enabled** and Disabled.



Note: If there is any change to this setting, you will need to power off and reboot the system for the change to take effect. Please refer to Intel's website for detailed information.

Active Processor Cores

Use this feature to select the number of active processor cores. The features are **All**, 1, 2, 3, and 4. These options depend on how many cores are supported by the CPU.

Hyper-Threading

Select Enabled to support Intel Hyper-threading Technology to enhance CPU performance. The options are **Enabled** and Disabled.

BIST

Select Enabled to activate the Built-In Self Test (BIST) on reset. The options are Enabled and **Disabled**.

AES

Select Enable for Intel CPU Advanced Encryption Standard (AES) Instructions support to enhance data integrity. The options are **Enabled** and Disabled.

Machine Check

Select Enable to activate Machine Check. The options are **Enabled** and Disabled.

MonitorMWait

Select Enable to activate MonitorMWait. The options are **Enabled** and Disabled.

Intel® Trusted Executed Technology

Intel TXT (Trusted Execution Technology) helps protect against software-based attacks and ensures protection, confidentiality and integrity of data stored or created on the system. The options are Enabled and **Disabled**.

*If Intel Trusted Execution Technology is Enabled, the options Alias Check Request and DPR Memory Size are available for configuration.

Alias Check Request

Use this feature to set up Alias Check Request. The options are Enabled and Disabled.

Reset AUX Content

Use this feature to reset the TPM Auxiliary content. The options are yes and **no**.

CPU SMM Enhancement

SMM Code Access Check

SMM Code Access is a special operating mode that is used by the BIOS to handle power and hardware management functions. The options are **Disabled** and Enabled.

SMM Use Delay Indication

Enable SMM Use Delay Indication to check whether a thread will be delayed while entering SMM. The options are **Disabled** and Enabled.

SMM Use Block Indication

Enable SMM Use Block Indication to check whether a thread is blocked from entering SMM. The options are **Disabled** and Enabled.

FCLK Frequency for Early Power On

Select the FCLK frequency for early power on. The options are Normal (800MHz), **1GHz**, and 400MHz.

Power and Performance

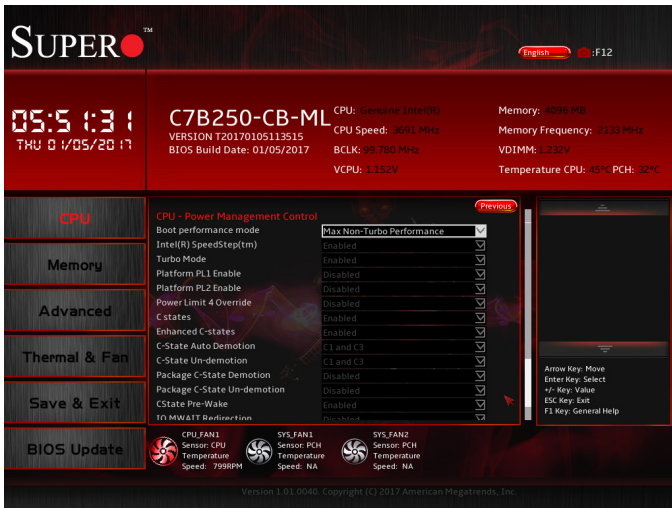

CPU - Power Management Control

Boot performance Mode

This feature enables the selection of the default CPU performance during system boot. The options are **Max Non-Turbo Performance**, Max Battery, and Turbo Performance.

Intel(R) SpeedStep(tm)

Intel SpeedStep Technology allows the system to automatically adjust processor voltage and core frequency in an effort to reduce power consumption and heat dissipation. **Please refer to Intel's website for detailed information.** The options are Disabled and **Enabled**.

Turbo Mode

This feature allows processor cores to run faster than the frequency recommended by the manufacturer. The options are Disabled and **Enabled**.

Platform PL1 Enable

This feature disables or enables the Platform Power Limit 1 programming. If this option is enabled, it activates the PL1 value to be used by the processor to limit the average power of the given time window. The options are **Disabled** and Enabled.

Platform PL2 Enable

This feature disables or enables the Platform Power Limit 2 programming. If this option is enabled, it activates the PL1 value to be used by the processor to limit the average power of the given time window. The options are **Disabled** and Enabled.

Power Limit 4 Override

This feature disables or enables the Power Limit 4 Override. If this option is disabled, the BIOS will program the default values for Power Limit and Power Limit 4 Time Window. The options are **Disabled** and Enabled.

C states

C-States architecture, a processor power management platform developed by Intel, can further reduce power consumption from the basic C1 (Halt State) state that blocks clock cycles to the CPU. Select Enabled for CPU C States support. The options are **Enabled** and Disabled. If this option is set to Enabled, the following items will display:

Enhanced C-states

(Available when "CPU C States" is set to Enabled)

Select Enabled to enable Enhanced C1 Power State to boost system performance. The options are **Enabled** and Disabled.

C-State Auto Demotion

When this feature is enabled, the CPU will conditionally demote C State based on un-cored auto-demote information. The options are Disabled, C1, C3, and **C1 and C3**.

C-State Un-demotion

When this feature is enabled, the CPU will conditionally undemote from demoted C3 or C1. The options are Disabled, C1, C3, and **C1 and C3**.

Package C-State Demotion

This feature enables the Package C-State demotion. The options are **Disabled** and Enabled.

Package C-State Un-Demotion

When this feature is enabled, the CPU will conditionally undemote from demoted Packaged Package C-State Un-Demotion. The options are **Disabled** and Enabled.

CState Pre-Wake

Use this feature to enable or disable the C-State pre wake. The options are **Enabled** and Disabled.

IO MWAIT Redirection

When enabled, this feature will map and send the IO read instructions to the IO registers. The options are **Disabled** and Enabled.

Package C State Limit

Select Auto for the BIOS to automatically set the limit on the C-State package register. The options are C0, C2, C3, C6, C7, C7s, and **Auto**.

Package C State Workaround

Enable this feature to fix old HDDs that have problems entering the Package C State. The options are **Disabled** and Enabled.

GT-Power Management

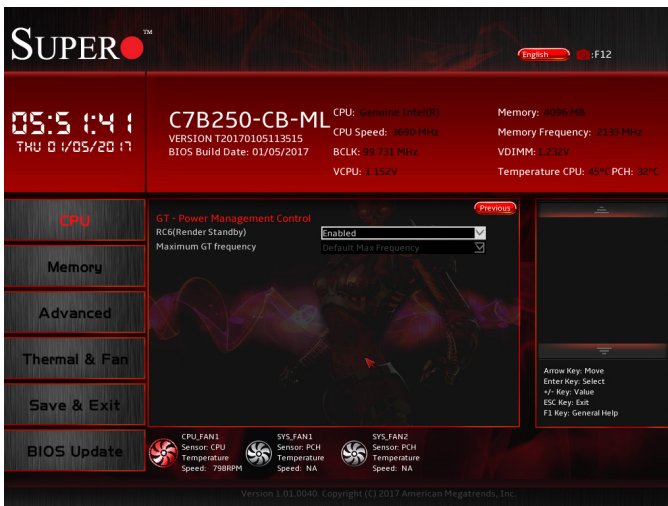

RC6 (Render Standby)

Use this feature enable Render Standby support. The options are **Enabled** and Disabled.

Maximum GT Frequency

This feature is the Maximum GT Frequency as defined by the user. Choose between 300MHz (RPN) and 1200MHz (RP0). Any value beyond this range will be clipped to its min/max supported by the CPU. The options are **Default Max Frequency**, 100MHz through 1200MHz in increments of 50MHz.

4-4 Memory

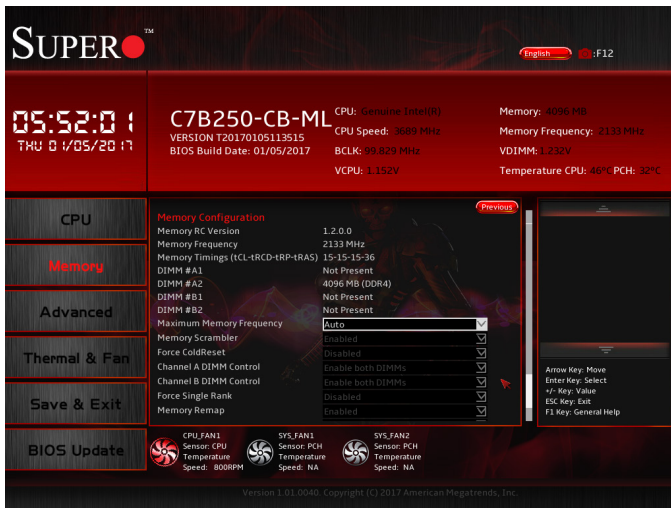

The following information is displayed in this section:

- **Memory RC Version**
- **Memory Frequency**
- **Memory Timings (tCL-tRCD-tRP-tRAS)**
- **DIMM#A1 ~ DIMM#B2**

Maximum Memory Frequency

This feature selects the type/speed of the memory installed. The options are 1333, 1600, 1867, 2133, 2400, 2667, 2933, and 3200. All values are in MHz. Default speed is **Auto** detected.

Memory Scrambler

This feature enables or disables memory scrambler support for memory error correction. The options are **Enabled** and Disabled.

Force ColdReset

Use this feature when ColdBoot is required during MRC execution. The options are Enabled and **Disabled**.

Channel A DIMM Control

This feature enables or disables the selected Channel A DIMM slot(s). The options are **Enable Both DIMMs**, Disable DIMM0, Disable DIMM1, and Disable Both DIMMs.

Channel B DIMM Control

This feature enables or disables the selected Channel B DIMM slot(s). The options are **Enable Both DIMMs**, Disable DIMM0, Disable DIMM1, and Disable Both DIMMs.

Force Single Rank

When enabled, only Rank0 will be use in each DIMM. The options are **Disabled** and Enabled.

Memory Remap

PCI memory resources will overlap with the total physical memory if 4GB of memory or above is installed on the motherboard. When this occurs, **Enable** this function to reallocate the overlapped physical memory to a location above the total physical memory to resolve the memory overlapping situation. The options are **Enabled** and Disabled.

MRC Fast Boot

This feature enables or disables fast path through MRC. The options are **Enabled** and Disabled.

4-5 Advanced

Boot Feature

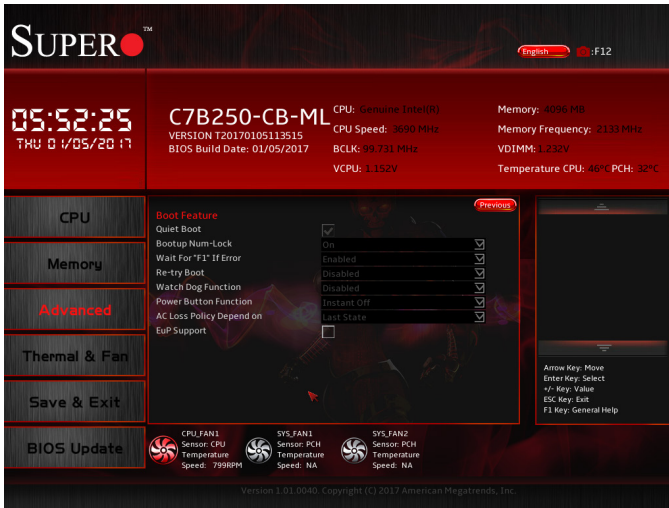

Quiet Boot

Use this feature to select the screen display between the POST messages and the OEM logo upon bootup. Uncheck the box to display the POST messages. Check the box to display the OEM logo instead of the normal POST messages.

Bootup Num-Lock

Use this feature to set the Power-on state for the <Numlock> key. The options are Off and **On**.

Wait for "F1" If Error

Use this feature to force the system to wait until the 'F1' key is pressed if an error occurs. The options are Disabled and Enabled.

Re-try Boot

If this feature is enabled, the BIOS will automatically reboot the system from a specified boot device after its initial boot failure. The options are **Disabled**, Legacy Boot, and EFI Boot.

Watch Dog Function

If enabled, the Watch Dog Timer will allow the system to reset or generate NMI based on jumper settings when it is expired for more than five minutes. The options are **Disabled** and Enabled.

Power Button Function

This feature controls how the system shuts down when the power button is pressed. Select 4 Seconds Override for the user to power off the system after pressing and holding the power button for four seconds or longer. Select Instant Off to instantly power off the system as soon as the user presses the power button. The options are **Instant Off** and 4 Seconds Override.

AC Loss Policy Depend On

Use this feature to set the power state after a power outage. Select Stay Off for the system power to remain off after a power loss. Select Power On for the system power to be turned on after a power loss. Select Last State to allow the system to resume its last power state before a power loss. The options are Stay Off, Power On, and **Last State**.

EUP Support

EUP, or Energy Using Product, is a European energy-saving specification that sets a standard on the maximum total power consumption on electrical products. Check the box to activate EUP support. The default is Unchecked (**Disabled**).

NCT6792D Super IO Configuration

SUPER™ English | F12

05:52:35
THU 01/05/2017

C7B250-CB-ML
VERSION T20170105113515
BIOS Build Date: 01/05/2017

CPU: Genuine Intel®
CPU Speed: 3600 MHz
BCLK: 10.731 MHz
VCPU: 1.152V

Memory: 4096 Mb
Memory Frequency: 2133 MHz
VDIMM: 1.232V
Temperature CPU: 48°C PCH: 32°C

Advanced

NCT6792D Super IO Configuration Previous

Super IO Chip: NCT6792D
Serial Port 1 Configuration

Arrow Key: Move
Enter Key: Select
+/- Key: Value
ESC Key: Exit
F3 Key: General Help

CPU_FAN1
Sensor: CPU
Temperature: 802RPM
Speed: 802RPM

SYS_FAN1
Sensor: PCH
Temperature: NA
Speed: NA

SYS_FAN2
Sensor: PCH
Temperature: NA
Speed: NA

Version 1.01.0040, Copyright (C) 2017 American Megatrends, Inc.

SuperIO Chip NCT6792D

Serial Port 1 Configuration

Serial Port

This feature will Enable or Disable Serial Port 1 (COM1). Place a tick mark on the box to enable Serial Port 1. The default is **Enabled**.

Device Settings

This feature displays the current IRQ setting for Serial Port 1 (COM1).

Change Settings

This feature configures the IRQ setting for Serial Port 1 (COM1).

The options for Serial Port 1 are **Auto**, IO=3F8h; IRQ=4, IO=3F8h; IRQ=3, 4, 5, 6, 7, 9, 10, 11, 12, IO=2F8h; IRQ=3, 4, 5, 6, 7, 9, 10, 11, 12), IO=3E8h; IRQ=3, 4, 5, 6, 7, 9, 10, 11, 12 and IO=2E8h; IRQ=3, 4, 5, 6, 7, 9, 10, 11, 12.

Serial Port Console Redirection

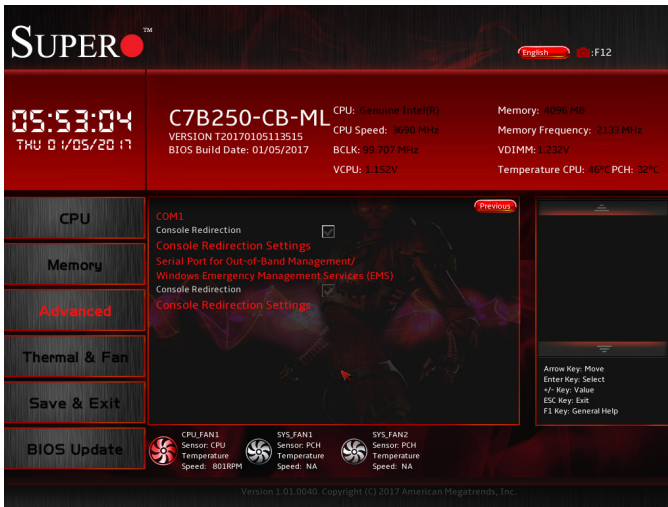

COM 1

Console Redirection

Select Enabled to enable COM Port 1 Console Redirection, which will allow a client machine to be connected to a host machine at a remote site for networking. The options are **Disabled (unchecked)** and Enabled (checked).

**If the feature above set to Enabled, the following features will become available for configuration:*

Console Redirection Settings

Terminal Type

This feature allows the user to select the target terminal emulation type for Console Redirection. Select VT100 to use the ASCII Character set. Select VT100+ to add color and function key support. Select ANSI to use the Extended ASCII Character Set. Select VT-UTF8 to use UTF8 encoding to map Unicode characters into one or more bytes. The options are **ANSI**, VT100, VT100+, and VT-UTF8.

Bits per second

Use this feature to set the transmission speed for a serial port used in Console Redirection. Make sure that the same speed is used in the host computer and the client computer. A lower transmission speed may be required for long and busy lines. The options are 9600, 19200, 38400, 57600, and **115200** (bits per second).

Data Bits

Use this feature to set the data transmission size for Console Redirection. The options are 7 (Bits) and **8 (Bits)**.

Parity

A parity bit can be sent along with regular data bits to detect data transmission errors. Select Even if the parity bit is set to 0, and the number of 1's in data bits is even. Select Odd if the parity bit is set to 0, and the number of 1's in data bits is odd. Select None if you do not want to send a parity bit with your data bits in transmission. Select Mark to add a mark as a parity bit to be sent along with the data bits. Select Space to add a Space as a parity bit to be sent with your data bits. The options are **None**, Even, Odd, Mark, and Space.

Stop Bits

A stop bit indicates the end of a serial data packet. Select 1 Stop Bit for standard serial data communication. Select 2 Stop Bits if slower devices are used. The options are **1** and 2.

Flow Control

Use this feature to set the flow control for Console Redirection to prevent data loss caused by buffer overflow. Send a "Stop" signal to stop sending data when the receiving buffer is full. Send a "Start" signal to start sending data when the receiving buffer is empty. The options are **None** and Hardware RTS/CTS.

VT-UTF8 Combo Key Support

Select Enabled to enable VT-UTF8 Combination Key support for ANSI/VT100 terminals. The options are **Enabled (checked)** and Disabled (unchecked).

Recorder Mode

Select Enabled to capture the data displayed on a terminal and send it as text messages to a remote server. The options are Enabled (checked) and **Disabled (unchecked)**.

Resolution 100x31

Select Enabled for extended-terminal resolution support. The options are **Enabled (checked)** and Disabled (unchecked).

Legacy OS Redirection Resolution

Use this feature to select the number of rows and columns used in Console Redirection for legacy OS support. The options are **80x24** and 80x25.

Putty KeyPad

This feature selects Function Keys and KeyPad settings for Putty, which is a terminal emulator designed for the Windows OS. The options are **VT100**, LINUX, XTERMR6, SCO, ESCN, and VT400.

Redirection After BIOS POST

Use this feature to enable or disable legacy Console Redirection after BIOS POST. When the option-Bootloader is selected, legacy Console Redirection is disabled before booting the OS. When the option- Always Enable is selected, legacy Console Redirection remains enabled upon OS bootup. The options are **Always Enable** and Bootloader.

Legacy Console Redirection

Legacy Console Redirection Settings

Legacy Serial Redirection Port

Select a COM port for Legacy Serial Redirection. The options are dependent on the available COM port(s).

Serial Port for Out-of-Band Management/Windows Emergency Management Services (EMS)

The submenu allows the user to configure Console Redirection settings to support Out-of-Band Serial Port management.

Console Redirection

Select Enabled to use a COM port selected by the user for EMS Console Redirection. The options are Enabled (checked) and **Disabled (unchecked)**.

**If the feature above set to Enabled, the following features will become available for user configuration:*

Console Redirection Settings

Out-of-Band Mgmt Port

The feature selects a serial port in a client server to be used by the Windows Emergency Management Services (EMS) to communicate with a remote host server. The options are **dependent on the available COM port(s)**.

Terminal Type

Use this feature to select the target terminal emulation type for Console Redirection. Select VT100 to use the ASCII character set. Select VT100+ to add color and function key support. Select ANSI to use the extended ASCII character set. Select VT-UTF8 to use UTF8 encoding to map Unicode characters into one or more bytes. The options are ANSI, VT100, VT100+, and **VT-UTF8**.

Bits per second

This feature sets the transmission speed for a serial port used in Console Redirection. Make sure that the same speed is used in both host computer and the client computer. A lower transmission speed may be required for long and busy lines. The options are 9600, 19200, 57600, and **115200** (bits per second).

Flow Control

Use this feature to set the flow control for Console Redirection to prevent data loss caused by buffer overflow. Send a "Stop" signal to stop data sending when the receiving buffer is full. Send a "Start" signal to start data sending when the receiving buffer is empty. The options are **None**, Hardware RTS/CTS, and Software Xon/Xoff.

The setting for each these features is displayed:

Data Bits, Parity, Stop Bits

System Agent (SA) Configuration



The following will be displayed:

- **SA PCIe Code Version**
- **VT-d Capability**

PEG Port Configuration

PEG 0:1:0

Enable Root Port

Select Enable to activate the Root Port. The options are Disabled, Enabled, and **Auto**.

Max Link Speed

Select **Auto**, Gen1, Gen2, or Gen3 to set the PEG Max Link Speed.

PEG0 Slot Power Limit Value

This feature sets the upper limit of the power supplied by the slot (in Watts). It is calculated by multiplying this value by the Slot Power Limit Scale. Valid range is from 0-255.

PEG0 Slot Power Limit Scale

This feature sets the scale of the Slot Power Limit Value (above). The options are **1.0x**, 0.1x, 0.01x, and 0.001x.

PEG0 Physical Slot Number

This feature sets the physical slot number attached to this port. The number has to be globally unique within the chassis. Valid range is from 0-8191.

PEG 0:1:1

Enable Root Port

Select Enable to activate the Root Port. The options are Disabled, Enabled, and **Auto**.

Max Link Speed

Select **Auto**, Gen1, Gen2, or Gen3 to set the PEG Max Link Speed.

PEG1 Slot Power Limit Value

This feature sets the upper limit of the power supplied by the slot (in Watts). It is calculated by multiplying this value by the Slot Power Limit Scale. Valid range is from 0-255.

PEG1 Slot Power Limit Scale

This feature sets the scale of the Slot Power Limit Value (above). The options are **1.0x**, 0.1x, 0.01x, and 0.001x.

PEG1 Physical Slot Number

This feature sets the physical slot number attached to this port. The number has to be globally unique within the chassis. Valid range is from 0-8191.

Graphics Turbo IMON Current

Use this feature to set the limit on the current voltage regulator. Valid range is 14-31. Default is **31**.

Skip Scanning of External Gfx Card

Use this feature to scan for External Gfx Card on PEG and PCH PCIE Ports. If this feature is enabled, the system will not scan for a new card. The options are **Disabled** and Enabled.

Primary Display

Use this feature to select the graphics device to be used as the primary display. Select from IGFX/PEG/PCI or select SG for switchable GFX. The options are **Auto**, IGFX, PEG, PCIE and SG.

Select PCIE Card

Use this feature to select either Elk Creek 4, PEG Eval or **Auto** to use on the platform.

External Gfx Card Primary Display Configuration

Primary PEG

This feature allows the user to select the primary PCI Express Graphics (PEG) slot. The options are **Auto**, PEG11, and PEG12.

Primary PCIE

This feature allows the user to specify which graphics card to be used as the primary graphics card. The options are **Auto**, PCIE1, PCIE2, PCIE3, PCIE4, PCIE5, PCIE6, PCIE7, PCIE8, PCIE9, PCIE10, PCIE11, PCIE12, PCIE13, PCIE14, PCIE15, PCIE16, PCIE17, PCIE18, and PCIE19.

Internal Graphics

This feature keeps the Internal Graphics Device (IGD) enabled, based on setup options. The options are **Auto**, Enabled, and Disabled.

GTT Size

Use this feature to set the memory size to be used by the graphics translation table (GTT). The options are 2MB, 4MB, and **8MB**.

Aperture Size

Use this feature to set the Aperture size, which is the size of system memory reserved by the BIOS for graphics device use. The options are 128MB, **256MB**, 512MB, 1024MB, and 2048MB.

DVMT Pre-Allocated

Dynamic Video Memory Technology (DVMT) allows dynamic allocation of system memory to be used for video devices to ensure best use of available system memory based on the DVMT 5.0 platform. The options are 0M, 4M, 8M, 12M, 16M, 20M, 24M, 28M, **32M**, 32M/F7, 36M, 40M, 44M, 48M, 52M, 56M, and 60M.

DVMT Total Gfx Mem

Use this feature to set the total memory size to be used by internal graphics devices based on the DVMT 5.0 platform. The options are 128MB, **256MB**, and MAX.

Gfx Low Power Mode

Select Enabled to use the low power mode for internal graphics devices installed in a small form factor (SFF) computer. The options are **Enabled** and Disabled.

VDD Enable

Activating this feature will force VDD in the BIOS. The options are Disabled and **Enabled**.

HDCP Support

Activating this feature will enable HDCP (High-bandwidth Digital Content Protection) BIOS support. The options are Disabled and **Enabled**.

Algorithm

Select either **One-Time** or Periodic for HDCP re-encryption flow.

PM Support

Activating this feature will enable Power Management BIOS support. The options are Disabled and **Enabled**.

PAVP Enable

Use the feature to enable Protect Audio Video Path Mode. The options are **Enabled** and Disabled.

Cdynmax Clamping Enable

Enable this feature to activate Cdynmas Clamping. The options are **Enabled** and Disabled.

Graphics Clock Frequency

Use this feature to set the internal graphics clock frequency. The options are 337.5MHz, 450MHz, 540MHz, and **675MHz**.

PCH-IO Configuration

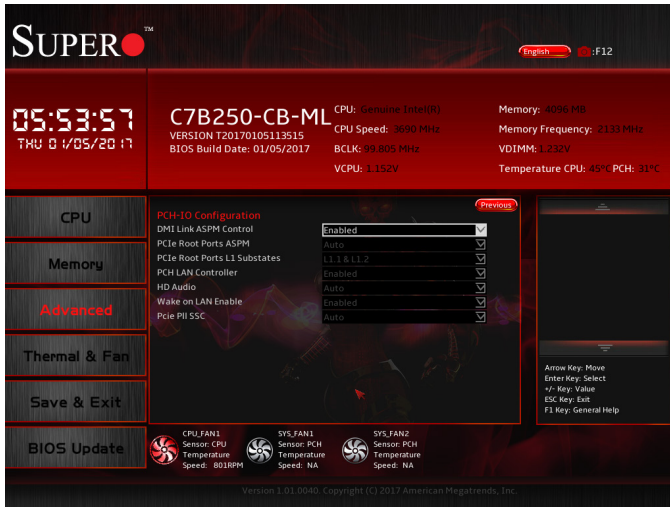

DMI Link ASPM Control

Use this feature to set the ASPM (Active State Power Management) state on the SA (System Agent) side of the DMI Link. The options are **Enabled** and Disabled.

PCIe Root Ports ASPM

Use this feature to set the Active State Power Management (ASPM) to power manage the PCIe link during the various L states. The options are **Auto**, L0sL1, L1, L0s, and Disabled.

PCIe Root Ports L1 Substates

Use this feature to define which L1 substate to use. The options are Disabled, L1.1, L1.2, and **L1.1&L1.2**.

PCH LAN Controller

Use this feature to enable or disable the PCH LAN Controller. The options are Disabled and **Enabled**.

HD Audio

Use this feature to detect an HD Audio device. The options are Disabled, Enabled, and **Auto**.

Wake on LAN Enable

Select Enabled to enable the capability to 'wake up' the system through the Ethernet port. The options are **Enabled** and Disabled.

Pcie PII SSC

Use this feature to set the PCIE PII SSC percentage. Select Auto to keep the hardware default with no BIOS override. The range is from 0.0% to 2.0%.

SATA and RST Configuration

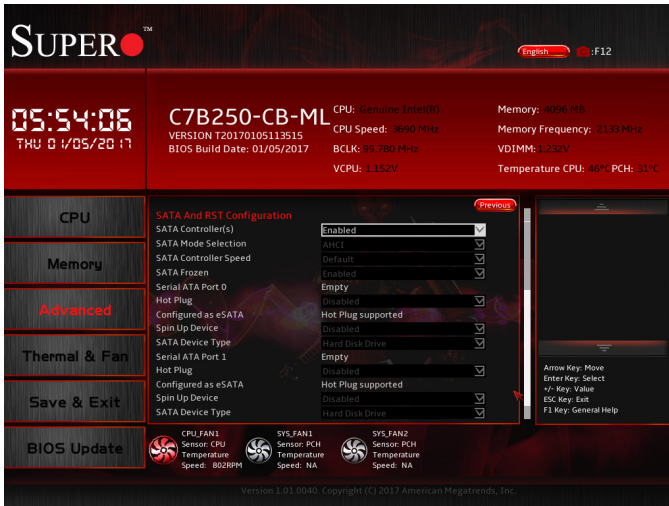

SATA Controllers

Select Disabled to disable the onboard SATA Controllers. The options are **Enabled** and Disabled.

SATA Mode Selection

This feature selects the mode for the installed SATA drives. The options are **AHCI** and Intel RST Premium.

SATA Controller Speed

Use this feature to specify the maximum speed the SATA controller can support. The options are **Default**, Gen 1, Gen 2, and Gen 3.

SATA Frozen

Select Disabled to disable the Freeze Lock Security feature. The options are **Enabled** and Disabled.

The remaining options in the section are similar across Serial ATA Ports 0 through 5.

Serial ATA Port

This feature displays the detected SATA drive, if any.

Hot Plug

This feature designates the port specified for hot plugging. Set this feature to Enabled for hot-plugging support, which will allow the user to replace a SATA disk drive without shutting down the system. The options are Enabled and **Disabled**.

Configured as eSATA

This feature displays the eSATA status for the detected hard drive.

Spin Up Device

When this feature is disabled, all drives will spin up at boot. When this option is enabled, it will perform Staggered Spin Up on any drive this option is activated. The options are Enabled and **Disabled**.

SATA Device Type

Use this feature to identify the type of HDD that is connected to the STATA port. The options are Hard Disk Drive and Solid State Drive.

PCH FW Configuration

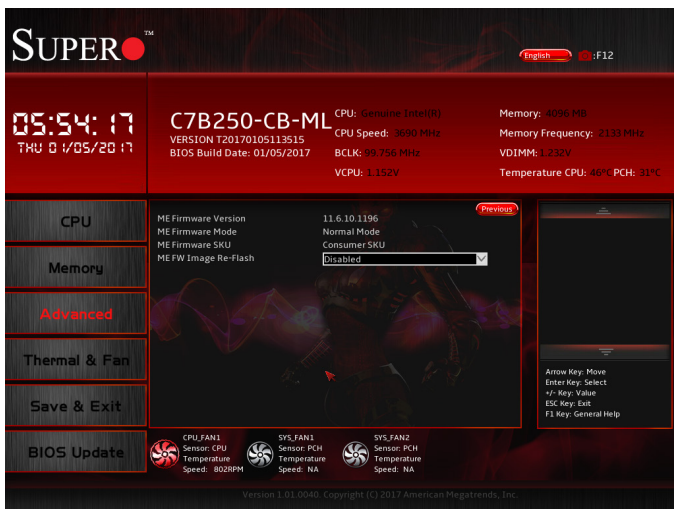

The following information is for the PCH Firmware.

- **ME Firmware Version**
- **ME Firmware Mode**
- **ME Firmware SKU**

ME FW Image Re-Flash

This feature will update the PCH Firmware from an image in a USB flash drive attached to a USB port. The options are Enabled and **Disabled**.

USB Configuration

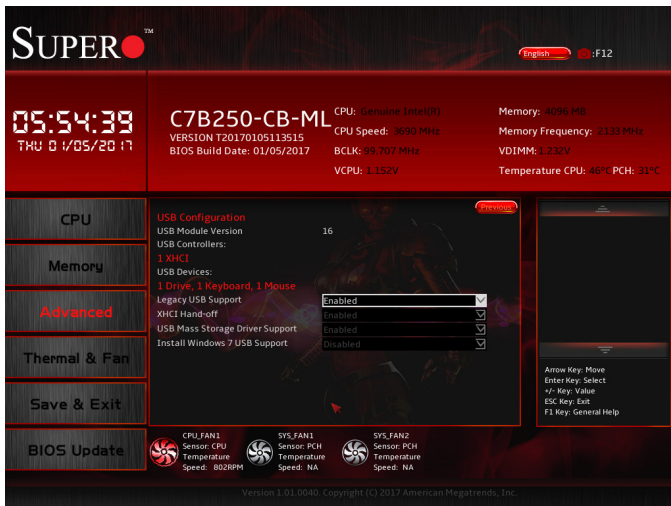

The following information is for USB Configuration.

- **USB Module Version**
- **USB Controllers**
- **USB Devices**

Legacy USB Support

Select Enabled to support legacy USB devices. Select Auto to disable legacy support when legacy USB devices are not present. If Disabled is selected, legacy USB devices will not be supported. The options are **Enabled**, Disabled, and Auto.

XHCI Hand-Off

This feature is a work-around solution for operating systems that do not support XHCI (Extensible Host Controller Interface) hand-off. The XHCI ownership change should be claimed by the XHCI driver. The options are **Enabled** and Disabled.

USB Mass Storage Driver Support

Select Enabled for USB mass storage device support. The options are Disabled and **Enabled**.

Install Windows 7 USB Support

Enable this feature to use the USB keyboard and mouse during the Windows 7 installation, since the native XHCI driver support is unavailable. Use a SATA optical drive as a USB drive, and USB CD/DVD drives are not supported. Disable this feature after the XHCI driver has been installed in Windows. The options are **Disabled** and **Enabled**.

PCIe/PCI/PnP Configuration

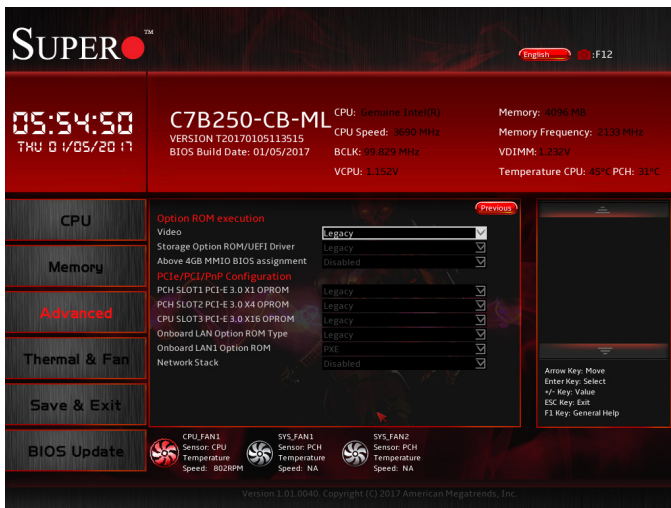

Option ROM Execution

Video

This feature controls which option ROM to execute for the Video device. The options are Do Not Launch, UEFI, and **Legacy**.

Storage Option ROM/UEFI Driver

This feature controls which option ROM to execute for the storage device. The options are Do Not Launch, UEFI, and **Legacy**.

Above 4GB MMIO BIOS Assignment

Select Enable for remapping of BIOS above 4GB. The options are Enabled and **Disabled**.

PCIe/PCI/PnP Configuration

PCH SLOT1 PCI-E 3.0 X1 OPROM, PCH SLOT2 PCI-E 3.0 X4 OPROM CPU SLOT3 PCI-E 3.0 X16 OPROM

Select Disabled to deactivate the selected slot, Legacy to activate the slot in legacy mode and EFI to activate the slot in EFI mode. The options are Disabled, **Legacy**, and EFI.

Onboard LAN Option ROM type

Use this feature to select the type of option ROM installed. The options are EFI and **Legacy**.

Onboard LAN1 Option ROM

Select PXE (Preboot Execution Environment) to boot the computer using a PXE device installed in a LAN port specified. Select Disabled to prevent system boot using a device installed in a LAN port. The options are Disabled and **PXE**.

Network Stack

Select Enabled to enable PXE (Preboot Execution Environment) or UEFI (Unified Extensible Firmware Interface) for network stack support. The options are Enabled and **Disabled**. If this feature is enabled, the two features below are available.

IPv4 PXE Support

Select Enabled to enable IPv4 PXE (Preboot Execution Environment) for boot support. If this feature is set to Disabled, IPv4 PXE boot option will not be supported. The options are **Enabled** and Disabled.

IPv6 PXE Support

Select Enabled to enable IPv6 PXE (Preboot Execution Environment) for boot support. If this feature is set to Disabled, IPv6 PXE boot option will not be supported. The options are Enabled and **Disabled**.

Security

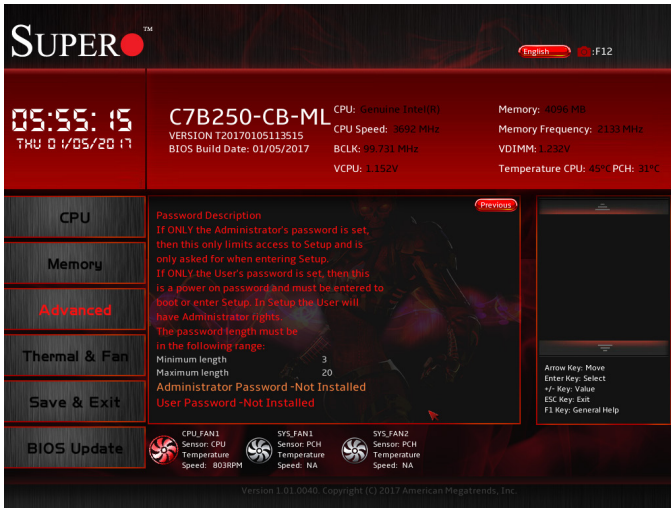

This menu allows the user to configure the following security settings for the system.

- If the Administrator password is defined ONLY - this controls access to the BIOS setup ONLY.
- If the User's password is defined ONLY - this password will need to be entered upon each system boot, and will also have Administrator rights in the setup.
- Passwords must be at least 3 and up to 20 characters long.

Administrator Password

Use this feature to set the Administrator Password which is required to enter the BIOS setup utility. The length of the password should be from 3 characters to 20 characters long.

User Password

Use this feature to set the User Password, which is required every time the system boots. The length of the password should be from 3 characters to 20 characters long.

Secure Boot

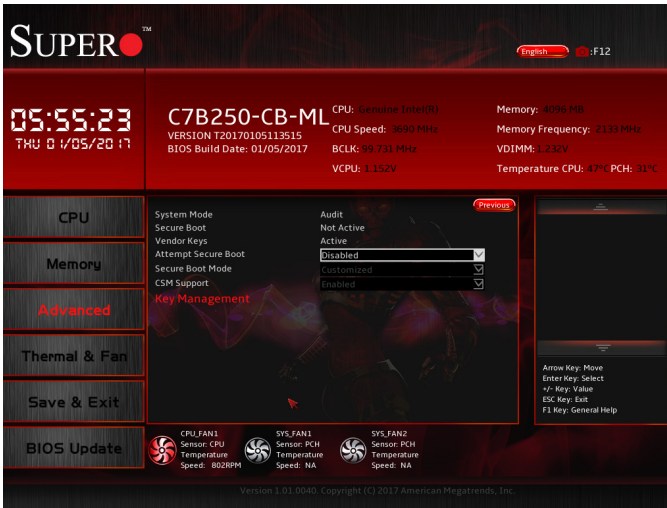

The following features will be displayed:

- **System Mode**
- **Secure Boot**
- **Vendor Keys**

Attempt Secure Boot

Select Enabled for Secure Boot flow control. This feature is available when the platform key (PK) is preregistered, the platform operates in the user mode, and CSM is disabled in the Setup utility. The options are **Disabled** and **Enabled**.

Secure Boot Mode

This feature allows selection of the Secure Boot Mode between Standard and Custom. Selecting Custom enables users to change the Image Execution Policy and manage Secure Boot Keys. The options are **Custom** and **Standard**.

CSM Support

Select enabled to support the Compatibility Support Module (CSM), which provides compatibility support for traditional legacy BIOS for system boot. The options are **Enabled** and **Disabled**.

Key Management

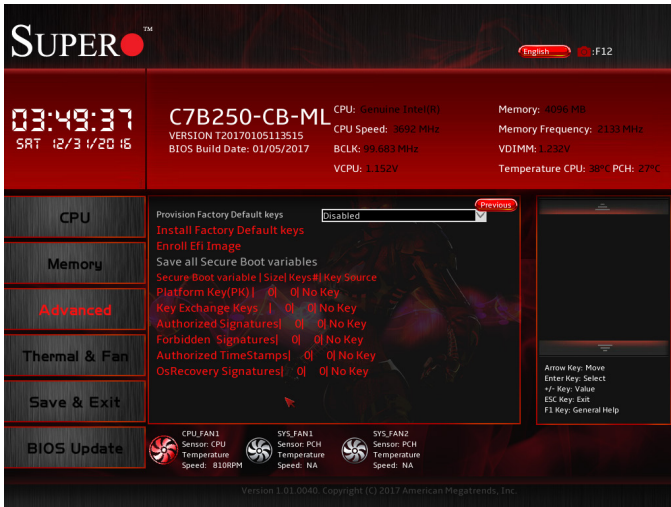

Provision Factory Default Keys

Allow provisioning the factory default secure boot keys when system is in setup mode. The options are **Disabled** and Enabled.

(if Secure Boot Mode is set to 'Custom')

Key Management allows experienced users to modify Secure Boot Variables.

Install Factory Default Keys

This feature forces the system to install the factory default keys. Click Yes or No.

Enroll Efi Image

This feature allows the image to run in Secure Boot Mode. Enroll SHA256 Hash Certificate of the image into the Authorized Signature Database.

Save All Secure Boot Variables

This feature saves all revised Secure Boot settings.

Platform Key (PK)

This feature uploads and installs a secure Platform Key. You may insert a factory default key or load from a file. The file formats accepted are:

- a. EFI Signature List
- b. EFI CERT X509 (DER Encoded)

- c. EFI CERT RSA2048 (bin)
 - d. EFI SERT SHA256 (bin)
- 2) EFI Time Based Authenticated Variable

When prompted, select "Yes" to load Factory Defaults or "No" to load from a file.

Delete Key Exchange Key

This feature deletes a previously installed Key Exchange Key.

Key Exchange Keys

This feature uploads and installs a Key Exchange Key. You may insert a factory default key or load from a file. When prompted, select "Yes" to load Factory Defaults or "No" to load from a file.

Append Key Exchange Key

This feature uploads and adds a Key Exchange Key into the Key Management. You may insert a factory default key or load from a file. When prompted, select "Yes" to load Factory Defaults or "No" to load from a file.

Delete Authorized Signature

This feature deletes a previously installed Authorized Signature.

Authorized Signatures

This feature uploads and installs an Authorized Signature . You may insert a factory default key or load from a file. The file formats accepted are:

- 1) Public Key Certificate
 - a. EFI Signature List
 - b. EFI CERT X509 (DER Encoded)
 - c. EFI CERT RSA2048 (bin)
 - d. EFI SERT SHA256 (bin)
- 2) EFI Time Based Authenticated Variable

When prompted, select "Yes" to load Factory Defaults or "No" to load from a file.

Append Authorized Signature

This feature uploads and adds an Authorized Signature into the Key Management. You may insert a factory default key or load from a file. When prompted, select "Yes" to load Factory Defaults or "No" to load from a file.

Delete Forbidden Signature

This feature deletes a previously installed Forbidden Signature.

Forbidden Signatures

This feature uploads and installs a Forbidden Signature. You may insert a factory default key or load from a file. The file formats accepted are:

1) Public Key Certificate

- a. EFI Signature List
- b. EFI CERT X509 (DER Encoded)
- c. EFI CERT RSA2048 (bin)
- d. EFI SERT SHA256 (bin)

2) EFI Time Based Authenticated Variable

When prompted, select "Yes" to load Factory Defaults or "No" to load from a file.

Append Forbidden Signature

This feature uploads and adds a Forbidden Signature into the Key Management. You may insert a factory default key or load from a file. When prompted, select "Yes" to load Factory Defaults or "No" to load from a file.

Delete Authorized TimeStamps

This feature deletes a previously installed Forbidden Signature.

Authorized TimeStamps

This feature uploads and installs an Authorized Time Stamp . You may insert a factory default key or load from a file. The file formats accepted are: 1) Public Key Certificate

- a. EFI Signature List
 - b. EFI CERT X509 (DER Encoded)
 - c. EFI CERT RSA2048 (bin)
 - d. EFI SERT SHA256 (bin)
- 2) EFI Time Based Authenticated Variable

When prompted, select "Yes" to load Factory Defaults or "No" to load from a file.

Append Authorized TimeStamp

This feature uploads and adds an Authorized TimeStamp into the Key Management. You may insert a factory default key or load from a file. When prompted, select "Yes" to load Factory Defaults or "No" to load from a file.

Delete OSRecovery Signatures

This feature deletes a previously installed OS Recovery Signature.

OsRecovery Signatures

This feature uploads and installs an OSRecovery Signature. You may insert a factory default key or load from a file. The file formats accepted are: 1) Public Key Certificate

- a. EFI Signature List
 - b. EFI CERT X509 (DER Encoded)
 - c. EFI CERT RSA2048 (bin)
 - d. EFI SERT SHA256 (bin)
- 2) EFI Time Based Authenticated Variable

When prompted, select "Yes" to load Factory Defaults or "No" to load from a file.

Append OsRecovery Signature

This feature uploads and adds an OSRecovery Signature into the Key Management. You may insert a factory default key or load from a file. When prompted, select "Yes" to load Factory Defaults or "No" to load from a file.

4-6 Thermal & Fan

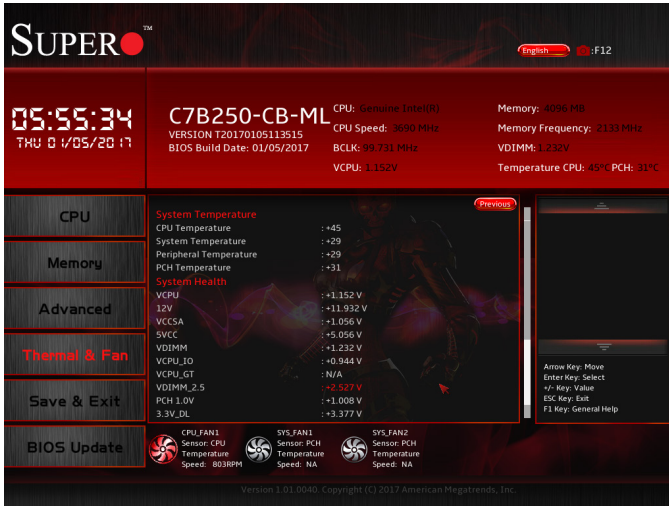

System Temperature

The following features will be displayed:

- **CPU Temperature** - displays the CPU temperature detected by PECI.
- **System Temperature** - indicates the system internal temperature.
- **Peripheral Temperature** - displays the detected peripheral device temperature.
- **PCH Temperature** - indicates the detected PCH chip temperature.

System Health

The following features will be displayed (Voltage):

- **VCPU**
- **12V**
- **VCCSA**
- **5VCC**
- **VDIMM**

- **VCPU_IO**
- **VCPU_GT**
- **VDIMM_2.5**
- **PCH 1.0V**
- **3.3V_DL**
- **USB**
- **3.3VCC**
- **VBAT**
- **VCPU_STPLL**

Fan Control

Fan Speed Control Mode

This feature allows the user to decide how the system controls the speeds of the onboard fans. The CPU temperature and the fan speed are correlative. When the CPU on-die temperature increases, the fan speed will also increase for effective system cooling. Select "Full Speed" to allow the onboard fans to run at full speed (of 100% Pulse Width Modulation Duty Cycle) for maximum cooling. This setting is recommended for special system configuration or debugging. Select "Stable" for the onboard fans to run at 50% of the Initial PWM Cycle in order to balance the needs between system cooling and power saving. This setting is recommended for regular systems with normal hardware configurations. Select "Quiet" to optimize for minimal fan noise and Custom to enter user-specific settings. The options are **Quiet**, Stable, Full Speed and Customize.

When "Customize" is selected above, the settings for **CPU_FAN1 Control**, **SYS FAN1/FAN2 Control** will appear and can be configured.

4-7 Save & Exit

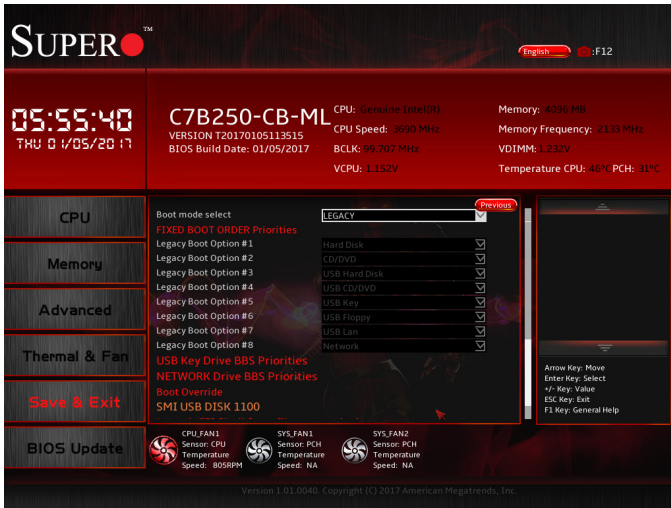

Boot mode select

Use this feature to select the type of device to be used for system boot. The options are **Legacy**, **UEFI**, and **Dual**.

FIXED BOOT ORDER Priorities

This feature prioritizes the order of bootable devices from which the system will boot. Choose an entry from top to bottom to select devices.

Legacy Boot Option #1~#8

The features are Hard Disk, CD/DVD, USB Hard Disk, USB CD/DVD, USB Key, USB Floppy, USB LAN, Network and Disabled.

USB Key Drive BBS Priorities

Use this feature to specify the Boot Device Priority sequence from available USB Key Drives. The options are **SMI USB DISK 110** and **Disable**.

NETWORK Drive BBS Priorities

Use this feature to specify the Boot Device Priority sequence from available Network Drives. The options are **IBA CL Slot 00FE v0110** and **Disable**.

Boot Override

Saves the specified boot override and resets the system, i.e., **IBA CL Slot 00FE v0110**. Select **OK** to activate, otherwise, click **Cancel**.

SMI USB DISK 1100

Launch EFI Shell from filesystem device

This feature will attempt to launch the EFI Shell application (shell.efi) from one of the available file system devices. Select OK to activate, otherwise, click Cancel.

For the following options, select OK to initiate, otherwise, click Cancel.

Save Changes and Reset

This feature will save the changes that have been made and will re-boot the system.

Discard Changes and Reset

This feature will save the changes that have been made and will re-boot the system.

Save Changes

This feature will save the changes but will remain in setup mode.

Discard Changes

This feature will discard the changes but will remain in setup mode.

4-8 BIOS Update

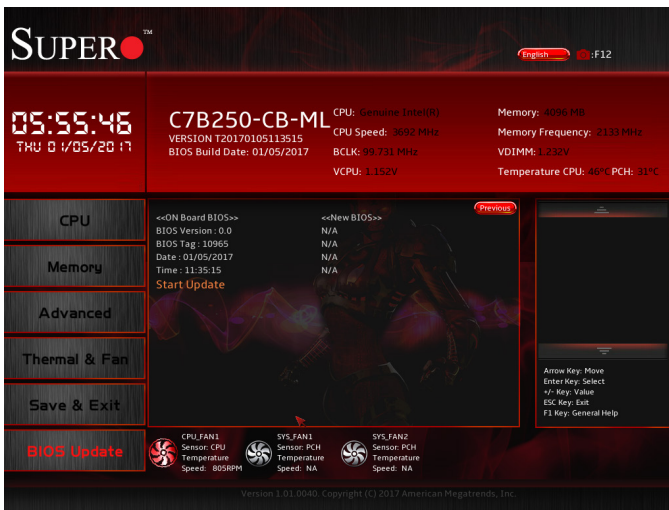

The following features will be displayed:

- **BIOS Version**
- **BIOS Tag**
- **Date**
- **Time**

Start Update

Use this utility to prepare BIOS Update with ME.

1. Click "Start Update" enter the SuperFlash utility.
2. At the prompt, select "Yes" to reboot and configure the system to Flash mode. Select "No" to cancel and view the BIOS information.
3. After the system reboots to the flash mode, the system is ready to flash the BIOS. At the prompt, select "OK" to continue.
4. Select "Select File" and then in the pop-up menu select "General USB Flash Disk 1.00."
5. Select the filename (i.e., "C7B250-CB-ML") in the pop-up menu.

6. Select "Start Flash" to flash the BIOS. A pop-up message will appear to show the progress of the BIOS flash.

7. If the flash is successful, a pop-up message will indicate the result. Select "OK" to complete the BIOS flash and to reboot the system. Go to the "SYSTEM INFORMATION - Motherboard" page in the BIOS Setup to check for the correct BIOS version.

Notes

Appendix A

BIOS Error Beep Codes

During the POST (Power-On Self-Test) routines, which are performed each time the system is powered on, errors may occur.

Non-fatal errors are those which, in most cases, allow the system to continue with bootup. The error messages normally appear on the screen.

Fatal errors will not allow the system to continue to boot up. If a fatal error occurs, you should consult with your system manufacturer for possible repairs.

These fatal errors are usually communicated through a series of audible beeps. The numbers on the fatal error list correspond to the number of beeps for the corresponding error.

Connect an external speaker to hear the beep codes.

A-1 BIOS Error Beep Codes

BIOS Error Beep Codes		
Beep Code/LED	Error Message	Description
1 beep	Refresh	Circuits have been reset. (Ready to power up)
5 short beeps + 1 long beep	Memory error	No memory detected in the system
5 short beeps	Display error	System display error
OH LED On	System OH	System Overheat

Notes

Appendix B

Software Installation Instructions

B-1 Installing Drivers

After you've installed the Windows Operating System, a screen as shown below will appear. You are ready to install software programs and drivers that have not yet been installed. To install these software programs and drivers, click the icons to the right of these items. (**Note:** To install the Windows Operating System, please refer to the instructions posted on our website at [http://www.supermicro.com/support/manuals/.](http://www.supermicro.com/support/manuals/))

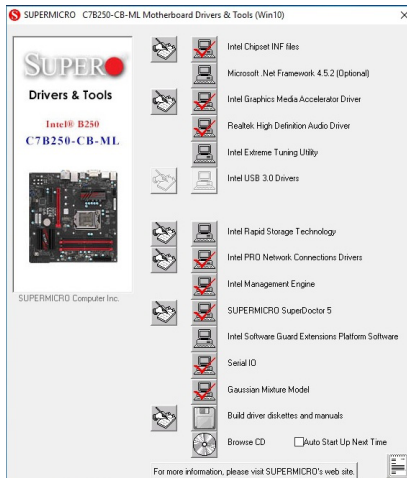

Driver/Tool Installation Display Screen



Note 1. Click the icons showing a hand writing on the paper to view the readme files for each item. Click on a computer icon to the right of an item to install this item (from top to bottom), one at a time. After installing each item, you must reboot the system before proceeding with the next item on the list. The bottom icon with a CD on it allows you to view the entire contents of the CD.

Note 2. When making a storage driver disk by booting into a Driver CD, please set the SATA Configuration to "Compatible Mode" and configure SATA as IDE in the BIOS Setup. After making the driver disk, be sure to change the SATA settings back to your original settings.

B-2 Configuring SuperDoctor® 5

The Supermicro SuperDoctor 5 is a hardware monitoring program that functions in a command-line or web-based interface in Windows and Linux operating systems. The program monitors system health information such as CPU temperature, system voltages, system power consumption, fan speed, and provides alerts via email or Simple Network Management Protocol (SNMP).

SuperDoctor 5 comes in local and remote management versions and can be used with Nagios to maximize your system monitoring needs. With SuperDoctor 5 Management Server (SSM Server), you can remotely control power on/off and reset chassis intrusion for multiple systems with SuperDoctor 5 or IPMI. SD5 Management Server monitors HTTP, FTP, and SMTP services to optimize the efficiency of your operation.



Note: The default Username and Password for SuperDoctor 5 is ADMIN / ADMIN. The SuperDoctor 5 program and user's manual can be downloaded from the Supermicro website at http://www.supermicro.com/products/nfo/sms_sd5.cfm.



SuperDoctor 5 Interface Display Screen-1 (Health Information)

Appendix C

BIOS Recovery Instructions

! **Attention!** Do not upgrade the BIOS unless your system has a BIOS-related issue. Flashing the wrong BIOS can cause irreparable damage to the system. In no event shall Supermicro be liable for direct, indirect, special, incidental, or consequential damages arising from a BIOS update. If you need to update the BIOS, do not shut down or reset the system while the BIOS is updating to avoid possible boot failure.

C-1 An Overview to the BIOS

The Unified Extensible Firmware Interface (UEFI) specification provides a software-based interface between the operating system and the platform firmware in the pre-boot environment. The UEFI specification supports an architecture-independent mechanism for add-on card initialization to allow the UEFI OS loader, which is stored in the add-on card, to boot up the system. UEFI offers a clean, hands-off control to a computer system at boot up.

C-2 How to Recover the BIOS Image (-the Main BIOS Block)

A BIOS flash chip consists of a recovery BIOS block, comprised of two boot blocks and a main BIOS block (a main BIOS image). The boot block contains critical BIOS codes, including memory detection and recovery codes for the user to flash a new BIOS image if the original main BIOS image is corrupted. When the system power is on, the boot block codes execute first. Once that is completed, the main BIOS code will continue with system initialization and bootup.



Note: Follow the BIOS Recovery instructions below for BIOS recovery when the main BIOS boot crashes. However, when the BIOS boot block crashes, you will need to follow the procedures in Appendix D.

C-3 To Recover the Main BIOS Block Using a USB-Attached Device

This feature allows the user to recover a BIOS image using a USB-attached device without additional utilities used. A USB flash device such as a USB Flash Drive, or a USB CD/DVD ROM/RW device can be used for this purpose. However, a USB Hard Disk drive cannot be used for BIOS recovery at this time.

To perform BIOS recovery using a USB-attached device, follow the instructions below.

1. Using a different machine, copy the "Super.ROM" binary image file into the disc Root "\ " Directory of a USB device or a writeable CD/DVD.



Note: If you cannot locate the "SUPER.ROM" file in your driver disk, visit our website at www.supermicro.com to download the BIOS image into a USB flash device (save in the root folder) and rename it "SUPER.ROM" for BIOS recovery use.

2. Insert the USB device that contains the new BIOS image ("SUPER.ROM") into any available USB port. Be sure the file is saved in the very top (root) folder.
3. Set the JBR1 switch on the motherboard to recovery mode and power on the system. If the screen appears as below, press to continue.

```
Version 2.18.1263. Copyright (C) 2016 American Megatrends, Inc.  
Supermicro C7B250-CB-ML BIOS Date:12/01/2016 Rev:T201612011
```

```
CPU : Intel(R) Core(TM) i3-6100TE CPU @ 2.70GHz  
Speed : 2.70 GHz  
The IMC is operating with DDR4 2133 MHz  
Setup default has been loaded.  
Press <DEL> to run Setup  
Press <F1> to Continue Booting
```

- After locating the new BIOS binary image, the system will enter the BIOS Recovery menu as shown below.

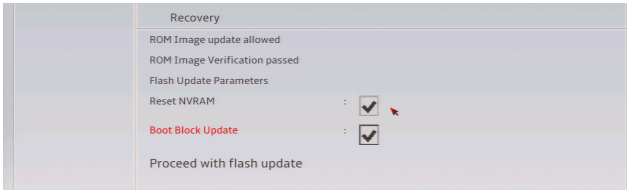

Note: At this point, you may decide if you want to start with BIOS Recovery. If you decide to proceed with BIOS Recovery, follow the procedures below.

- To continue with BIOS Recovery, select the item "Proceed with flash update." You will see the progress of BIOS Recovery as shown on the screens below.

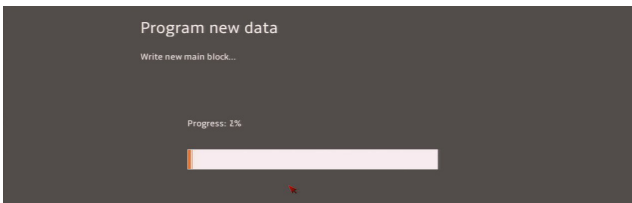
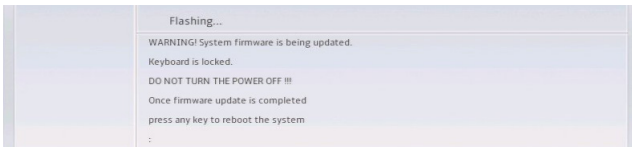

Note: *Do not interrupt* the BIOS programming until it is completed.

- After the BIOS Recovery process is complete, click OK to reboot the system.

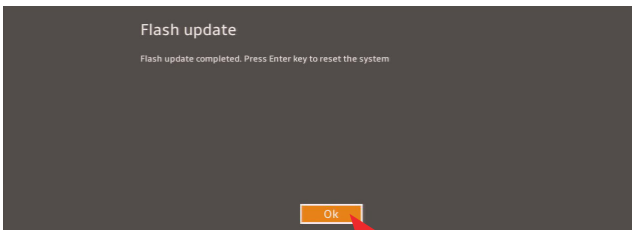

Notes

Appendix D

Dual Boot Block

D-1 Introduction

This motherboard supports the Dual Boot Block feature, which is the last-ditch mechanism to recover the BIOS boot block. This section provides an introduction to the feature.

BIOS Boot Block

A BIOS boot block is the minimum BIOS loader required to enable necessary hardware components for the BIOS crisis recovery flash that will update the main BIOS block. An on-call BIOS boot-block corruption may occur due to a software tool issue (refer to image below) or an unexpected power outage during BIOS updates.

```
-----
                AMI Firmware Update Utility vX.XX.XX
                Copyright (C)XXXX American Megatrends Inc. All Rights Reserved.
-----
```

```
Reading flash . . . . . done
-- ME Data Size checking . ok
-- FFS checksums . . . . . ok
Erasing Boot Block . . . . . done
_ Updating Boot Block . . . . . 0x00A91000 (13%)
```

BIOS Boot Block Corruption Occurrence

When a BIOS boot block is corrupted due to an unexpected power outage or a software tool malfunctioning during BIOS updates, you can still reboot the system by activating switch JBR1 on the motherboard. When JBR1 is activated, the system will boot from a backup boot block pre-loaded in the BIOS by the manufacturer.

D-2 Steps to Reboot the System by switch JBR1

1. Power down the system.
2. On switch JBR1 slide switch to ON, and power on the system.
3. Follow the BIOS recovery SOP listed in the previous chapter (Appendix C).
4. After completing the steps above, power down the system.
5. Turn OFF switch JBR1, and power on the system.

(Disclaimer Continued)

The products sold by Supermicro are not intended for and will not be used in life support systems, medical equipment, nuclear facilities or systems, aircraft, aircraft devices, aircraft/emergency communication devices or other critical systems whose failure to perform be reasonably expected to result in significant injury or loss of life or catastrophic property damage. Accordingly, Supermicro disclaims any and all liability, and should buyer use or sell such products for use in such ultra-hazardous applications, it does so entirely at its own risk. Furthermore, buyer agrees to fully indemnify, defend and hold Supermicro harmless for and against any and all claims, demands, actions, litigation, and proceedings of any kind arising out of or related to such ultra-hazardous use or sale.