



BH4SRG

USER'S MANUAL

Revision 1.0 (MNL-2866)

The information in this User's Manual has been carefully reviewed and is believed to be accurate. The vendor assumes no responsibility for any inaccuracies that may be contained in this document, and makes no commitment to update or to keep current the information in this manual, or to notify any person or organization of the updates. Note: For the most up-to-date version of this manual, see our website at <https://www.supermicro.com>.

Super Micro Computer, Inc. ("Supermicro") reserves the right to make changes to the product described in this manual at any time and without notice. This product, including software and documentation, is the property of Supermicro and/or its licensors, and is supplied only under a license. Any use or reproduction of this product is not allowed, except as expressly permitted by the terms of said license.

IN NO EVENT WILL Super Micro Computer, Inc. BE LIABLE FOR DIRECT, INDIRECT, SPECIAL, INCIDENTAL, SPECULATIVE OR CONSEQUENTIAL DAMAGES ARISING FROM THE USE OR INABILITY TO USE THIS PRODUCT OR DOCUMENTATION, EVEN IF ADVISED OF THE POSSIBILITY OF SUCH DAMAGES. IN PARTICULAR, SUPER MICRO COMPUTER, INC. SHALL NOT HAVE LIABILITY FOR ANY HARDWARE, SOFTWARE, OR DATA STORED OR USED WITH THE PRODUCT, INCLUDING THE COSTS OF REPAIRING, REPLACING, INTEGRATING, INSTALLING OR RECOVERING SUCH HARDWARE, SOFTWARE, OR DATA.

Any disputes arising between manufacturer and customer shall be governed by the laws of Santa Clara County in the State of California, USA. The State of California, County of Santa Clara shall be the exclusive venue for the resolution of any such disputes. Supermicro's total liability for all claims will not exceed the price paid for the hardware product.

FCC Statement: This equipment has been tested and found to comply with the limits for a Class A or Class B digital device pursuant to Part 15 of the FCC Rules. These limits are designed to provide reasonable protection against harmful interference when the equipment is operated in industrial environment for Class A device or in residential environment for Class B device. This equipment generates, uses, and can radiate radio frequency energy and, if not installed and used in accordance with the manufacturer's instruction manual, may cause harmful interference with radio communications. Operation of this equipment in a residential area is likely to cause harmful interference, in which case you will be required to correct the interference at your own expense.

California Best Management Practices Regulations for Perchlorate Materials: This Perchlorate warning applies only to products containing CR (Manganese Dioxide) Lithium coin cells. "Perchlorate Material-special handling may apply. See <https://www.dtsc.ca.gov/hazardouswaste/perchlorate>".



WARNING: This product can expose you to chemicals including lead, known to the State of California to cause cancer and birth defects or other reproductive harm. For more information, go to <https://www.P65Warnings.ca.gov>.



AVERTISSEMENT : Ce produit peut vous exposer à des agents chimiques, y compris le plomb, identifié par l'État de Californie comme pouvant causer le cancer, des malformations congénitales ou d'autres troubles de la reproduction. Pour de plus amples informations, prière de consulter <https://www.P65Warnings.ca.gov>.

The products sold by Supermicro are not intended for and will not be used in life support systems, medical equipment, nuclear facilities or systems, aircraft, aircraft devices, aircraft/emergency communication devices or other critical systems whose failure to perform be reasonably expected to result in significant injury or loss of life or catastrophic property damage. Accordingly, Supermicro disclaims any and all liability, and should buyer use or sell such products for use in such ultra-hazardous applications, it does so entirely at its own risk. Furthermore, buyer agrees to fully indemnify, defend and hold Supermicro harmless for and against any and all claims, demands, actions, litigation, and proceedings of any kind arising out of or related to such ultra-hazardous use or sale.

Manual Revision 1.0

Release Date: November 10, 2025

Unless you request and receive written permission from Super Micro Computer, Inc., you may not copy any part of this document. Information in this document is subject to change without notice. Other products and companies referred to herein are trademarks or registered trademarks of their respective companies or mark holders.

Copyright © 2025 by Super Micro Computer, Inc.
All rights reserved.

Published in the United States of America

Preface

About This Manual

This manual is written for professional system integrators and PC technicians. It provides information for the installation and use of the BH4SRG motherboard. Installation and maintenance should be performed by certified service technicians only.

Notes

For your system to work properly, follow the links below to download all necessary drivers/utilities and the user's manual for your motherboard.

- Supermicro product manuals: <https://www.supermicro.com/support/manuals>
- Product drivers and utilities: <https://www.supermicro.com/wdl>
- Product safety info: https://www.supermicro.com/about/policies/safety_information.cfm
- A secure data deletion tool designed to fully erase all data from storage devices can be found on our website:
https://www.supermicro.com/about/policies/disclaimer.cfm?url=/wdl/utility/Lot9_Secure_Data_Deletion_Utility
- Frequently Asked Questions: <https://www.supermicro.com/FAQ/index.php>
- If you still have questions after referring to our FAQs, contact our support team. Region-specific Technical Support email addresses can be found at: "[Contacting Supermicro](#)" on page 9
- If you have any feedback on Supermicro product manuals, contact our writing team at: Techwriterteam@supermicro.com

This manual may be periodically updated without notice. Check the Supermicro website for possible updates to the manual revision level.

Conventions Used in the Manual

Special attention should be given to the following symbols for proper installation and to prevent damage done to the components or injury to yourself.



Warning! Indicates important information given to prevent equipment/property damage or personal injury.



Warning! Indicates high voltage may be encountered while performing a procedure.

Important: Important information given to ensure proper motherboard installation or to relay safety precautions.

Note: Additional information given to differentiate various models or to provide information for proper motherboard setup.

Contents

Contacting Supermicro	9
Chapter 1: Introduction	10
1.1 Quick Reference	11
Checklist	11
Motherboard Layout	12
Quick Reference Table	14
Motherboard Features	15
Motherboard Block Diagram	17
1.2 Platform Overview	18
1.3 Special Features	19
Recovery from AC Power Loss	19
1.4 System Health Monitoring	20
Onboard Voltage Monitors	20
Fan Status Monitor with Firmware Control	20
Environmental Temperature Control	20
1.5 ACPI Features	21
Chapter 2: Component Installation	22
2.1 Static-Sensitive Devices	24
Precautions	24
Unpacking	24
Motherboard Installation	24
Tools Needed	25
Installing the Motherboard	25
2.2 Processor and Heatsink Installation	27
The AMD EPYC™ 4004 and 4005 Series Desktop Processor	27
Overview of the Processor Socket	28
Overview of the Heatsink	28
Installing the Processor	29
Installing the Heatsink	31
2.3 Memory Support and Installation	33
Memory Support	33

General Guidelines for Optimizing Memory Performance	33
DIMM Installation	34
DIMM Removal	36
2.4 Battery Removal and Installation	38
Battery Removal	38
Proper Battery Disposal	38
Battery Installation	38
2.5 Connections, Jumpers, and LEDs	39
Power Supply and Power Connections	39
Power Connector	39
Power Supply	39
Headers and Connections	39
M.2 M-Key PCIe 5.0 x2 Slot	39
M.2 M-Key PCIe 5.0 x4 Slot	40
MCIO PCIe 5.0 x8 Connectors	40
Power Distributor Board Sideband Signal Header	40
System Cooling Fan Header	40
Trusted Platform Module	40
Front Control Panel Board and I/O Connector	41
Front Control Panel Connector	41
Jumper Settings	42
CMOS Clear	42
Onboard TPM Enable/Disable	43
VGA Enable/Disable	43
Watchdog Timer	44
LED Indicators	44
BMC Heartbeat LED	44
Chapter 3: Troubleshooting	45
3.1 Troubleshooting Procedures	46
Before Power On	46
No Power	46
No Video	46
System Boot Failure	46
Memory Errors	47

Losing the System's Setup Configuration	47
If the System Becomes Unstable	47
3.2 Technical Support Procedures	49
3.3 Motherboard Battery	50
3.4 Where to Get Replacement Components	51
3.5 Returning Merchandise for Service	52
3.6 Feedback	53
Chapter 4: UEFI BIOS	54
4.1 Introduction	55
Starting the Setup Utility	55
4.2 Main Setup	56
4.3 Advanced Setup Configurations	58
Boot Feature Menu	58
CPU Configuration Menu	60
North Bridge Configuration Menu	61
Trusted Computing Menu	62
AMD fTPM Configuration	63
Super IO Configuration Menu	64
Serial Port 1 Configuration Menu	64
Serial Port 2 Configuration Menu	64
Serial Port Console Redirection Menu	65
SATA Configuration Menu	68
PCIe/PCI/PnP Configuration Menu	69
USB Configuration	70
Network Configuration Menu	70
HTTP Boot Configuration Menu	71
Supermicro KMS Server Configuration Menu	72
Super-Guardians Configuration Menu	74
TLS Authenticate Configuration Menu	76
Driver Health Menu	78
4.4 BMC	79
System Event Log Menu	79
BMC Network Configuration Menu	80
4.5 Security	83

4.6 Boot	87
4.7 Save & Exit	89
Appendix 5: Software	91
Microsoft Windows OS Installation	91
Installing the OS	91
Driver Installation	93
BMC	94
BMC ADMIN User Password	95
Appendix 6: Standardized Warning Statements	96
Battery Handling	96
Product Disposal	98

Contacting Supermicro

Headquarters

Address: Super Micro Computer, Inc.
980 Rock Ave.
San Jose, CA 95131 U.S.A.

Tel: +1 (408) 503-8000

Fax: +1 (408) 503-8008

Email: Marketing@supermicro.com (General Information)
Sales-USA@supermicro.com (Sales Inquiries)
Government_Sales-USA@supermicro.com (Gov. Sales Inquiries)
Support@supermicro.com (Technical Support)
RMA@Supermicro.com (RMA Support)
Webmaster@supermicro.com (Webmaster)

Website: <https://www.supermicro.com>

Europe

Address: Super Micro Computer B.V.
Het Sterrenbeeld 28, 5215 ML
's-Hertogenbosch, The Netherlands

Tel: +31 (0) 73-6400390

Fax: +31 (0) 73-6416525

Email: Sales_Europe@supermicro.com (Sales Inquiries)
Support_Europe@supermicro.com (Technical Support)
RMA_Europe@supermicro.com (RMA Support)

Website: <https://www.supermicro.nl>

Asia-Pacific

Address: Super Micro Computer, Inc.
3F, No. 150, Jian 1st Rd.
Zhonghe Dist., New Taipei City 235 Taiwan (R.O.C)

Tel: +886 (2) 8226-3990

Fax: +886 (2) 8226-3992

Email: Sales-Asia@supermicro.com.tw (Sales Inquiries)
Support@supermicro.com.tw (Technical Support)
RMA@supermicro.com.tw (RMA Support)

Website: <https://www.supermicro.com.tw>

Chapter 1:

Introduction

Congratulations on purchasing your computer motherboard from an industry leader. Supermicro motherboards are designed to provide you with the highest standards in quality and performance.

1.1 Quick Reference	11
Checklist	11
Motherboard Layout	12
Quick Reference Table	14
Motherboard Features	15
Motherboard Block Diagram	17
1.2 Platform Overview	18
1.3 Special Features	19
Recovery from AC Power Loss	19
1.4 System Health Monitoring	20
Onboard Voltage Monitors	20
Fan Status Monitor with Firmware Control	20
Environmental Temperature Control	20
1.5 ACPI Features	21

1.1 Quick Reference

For details on the BH4SRG motherboard layout, features, and other quick reference information, refer to the content below.

Checklist

In addition to the BH4SRG motherboard, several important parts that are included in your shipment are listed below. If anything listed is damaged or missing, contact your retailer.

Main Parts List		
Description	Part Number	Quantity
Supermicro Motherboard	BH4SRG	1
Quick Reference Guide	MNL-2866-QRG	1

Motherboard Layout

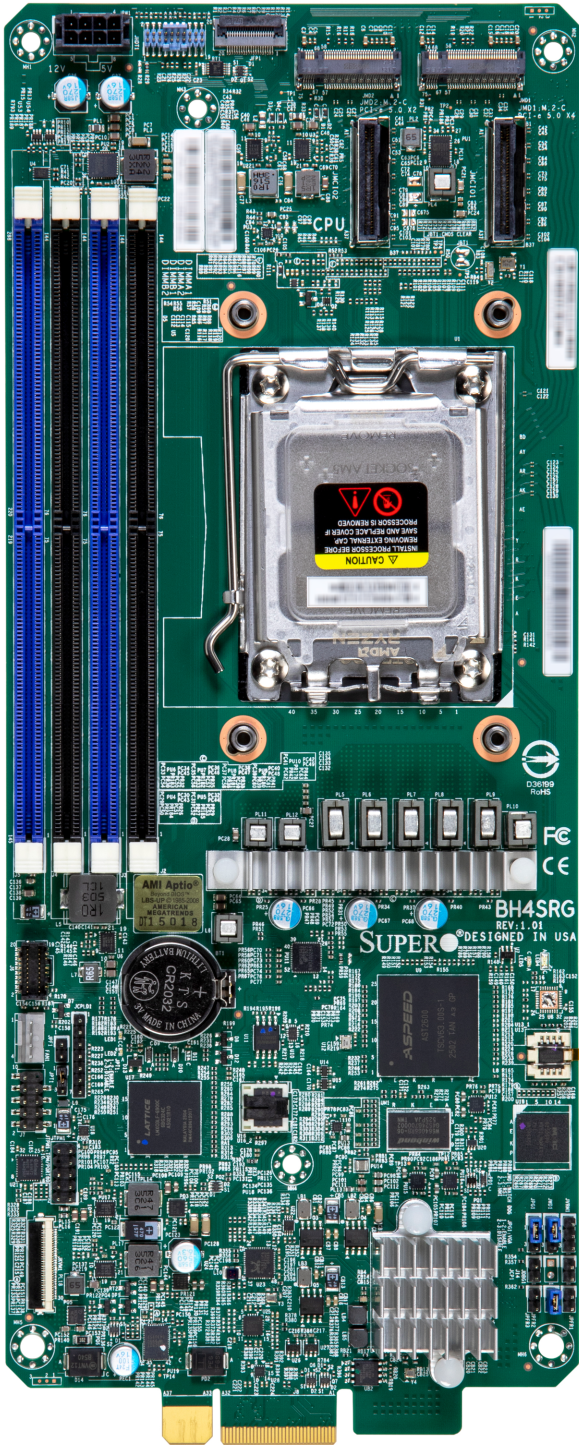

Figure 1-1. BH4SRG Motherboard Image

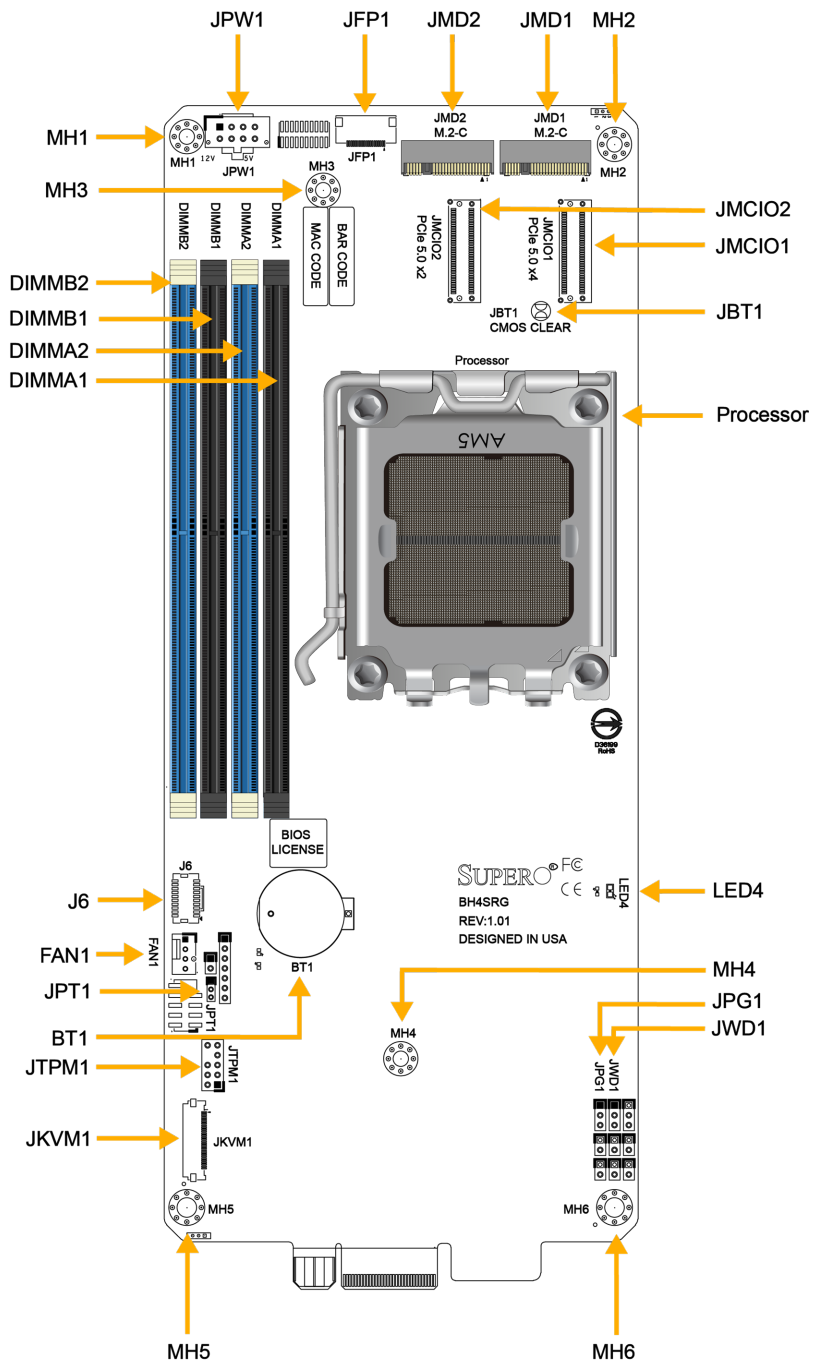

Figure 1-2. BH4SRG Motherboard Layout

Notes:

- For detailed information on jumpers, connectors, and LED indicators, see "[Component Installation](#)" on page 22.
- "■" indicates the location of pin 1.
- "MH" indicates the location of a mounting hole.
- Components not documented are for internal testing purposes only.
- Use only the correct type of onboard CMOS battery as specified by the manufacturer. To avoid possible explosion, do not install the onboard battery upside down.

Quick Reference Table

Jumper	Description	Default Setting
JBT1	CMOS Clear	Open (Normal)
JPG1	VGA Enable/Disable	Pins 1–2 (Enabled)
JPT1	Onboard TPM 2.0 Enable/Disable	Pins 1–2 (Enabled)
JWD1	Watchdog Timer	Pins 1–2 (Reset)

Connector	Description
FAN1	System Cooling Fan Header
J6	Power Distributor Board Sideband Signal Header
JFP1	Front Control Panel Connector
JMD1	M.2 Slot 2280/22110 M-Key (PCIe 5.0 x4)
JMD2	M.2 Slot 2280/22110 M-Key (PCIe 5.0 x2)
JMCO1/JMCO2	MCIO PCIe 5.0 x8 Connectors
JPW1	8-pin +12 V/+5 V Power Connector
JTPM1	Trusted Platform Module
JKVM1	VGA/USB Module Connector

LED	Description	Status
LED4	BMC Heartbeat LED	Blinking Green: BMC Normal

Motherboard Features

Motherboard Features
Processor
<ul style="list-style-type: none"> Supports a single AMD EPYC™ 4004/4005 processor with a Thermal Design Power (TDP) of up to 170 W in an AM5 socket
Memory
<ul style="list-style-type: none"> Supports up to 192 GB of ECC and Non-ECC DDR5 UDIMM memory with speeds of up to 5600 MT/s in two DIMM slots or up to 3600 MT/s in four DIMM slots
Chipset
<ul style="list-style-type: none"> System on Chip
DIMM Size
<ul style="list-style-type: none"> 16 GB, 24 GB, 32 GB, and 48 GB
Expansion Slots
<ul style="list-style-type: none"> One PCIe 5.0 x4 M.2 slot for 22110/2280 M.2 M-Key drive One PCIe 5.0 x2 M.2 slot for 22110/2280 M.2 M-Key drive
Network Controllers
<ul style="list-style-type: none"> BCM57414 Dual-Port 10 GbE
Baseboard Management Controller (BMC)
<ul style="list-style-type: none"> Aspeed AST 2600
Graphics
<ul style="list-style-type: none"> Aspeed AST 2600
I/O Devices
<ul style="list-style-type: none"> Two PCIe 5.0 x8 connectors for GPU One TPM 2.0 header
Peripheral Devices
<ul style="list-style-type: none"> N/A
BIOS
<ul style="list-style-type: none"> 256 Mb SPI AMI BIOS® SM Flash UEFI BIOS ACPI 6.4, SMBIOS 3.5.0 or later versions, and Plug and Play (PnP)
Power Management
<ul style="list-style-type: none"> ACPI power management (S5) Power-on mode for AC power recovery

Motherboard Features
System Health Monitoring
<ul style="list-style-type: none"> • Onboard voltage monitoring for +3.3 V, +5 V, +12 V, +3.3 VStb, +5 Stb, CPU temperature, system temperature, memory temperature, and peripheral temperature • CPU Thermal Trip support • Platform Environment Control Interface (PECI)/TSI
Fan Control
<ul style="list-style-type: none"> • One 4-pin fan header • Fans monitored by IPMI
System Management
<ul style="list-style-type: none"> • Trusted Platform Module (TPM) support • SuperDoctor® 5 • SAA-InBand, SAA-OOB • Intelligent Platform Management Interface (IPMIView, SMCIPMITOOL, IPMICFG)
LED Indicators
<ul style="list-style-type: none"> • BMC Heartbeat LED
Dimensions
<ul style="list-style-type: none"> • 4.8" x 12" (121.92 mm x 304.8 mm) (L x W) Proprietary

Note: The processor maximum thermal design power (TDP) is subject to chassis and heatsink cooling restrictions. For proper thermal management, check the chassis and heatsink specifications for proper processor TDP sizing.

Motherboard Block Diagram

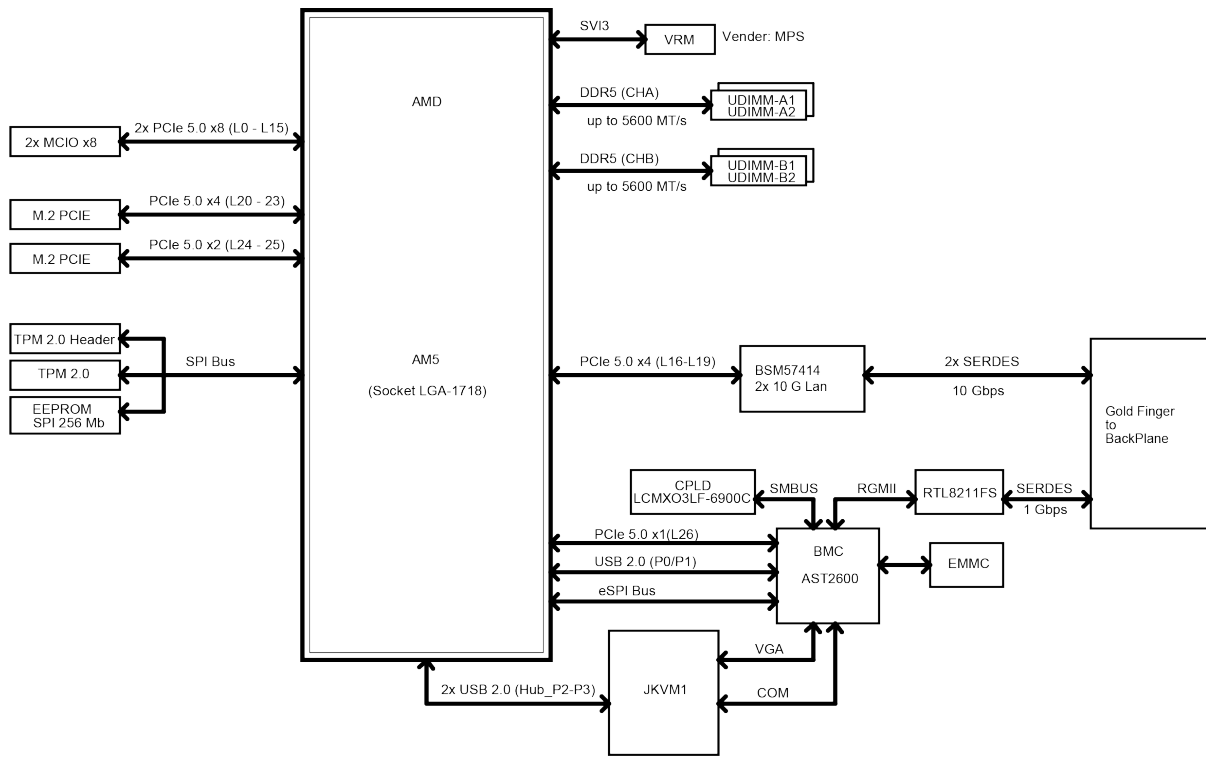

Figure 1-3. Motherboard Block Diagram

Note: This is a general block diagram and may not exactly represent the features on your motherboard. For the actual specifications of your motherboard, see the previous pages.

1.2 Platform Overview

Built upon the functionality and capability of the AMD EPYC™ 4004/4005 in Socket AM5, the BH4SRG motherboard offers maximum I/O expandability, energy efficiency, and data reliability in a 3 nm process architecture, and is optimized for embedded storage solutions, networking applications, or cloud-computing platforms.

With the support of new micro-architecture 3 nm process technology, it increases system performance for a multitude of server applications.

The following features are supported by the AMD EPYC™ 4004/4005:

- ACPI Power Management Logic Support Rev. 6.5
- Adaptive Thermal Management/Monitoring
- PCIe 5.0 with a transfer rate up to 32 GT/s and SATA 3.0 with a transfer rate of up to 6.0 Gb/s
- System Management Bus (SMBus) Specification Version 3.1.1

1.3 Special Features

Recovery from AC Power Loss

The Basic I/O System (BIOS) provides a setting that determines how the system will respond when AC power is lost and then restored to the system. You can choose for the system to remain powered off (in which case you must press the power switch to turn it back on), or for it to automatically return to the power-on state. See Advanced Setup Configurations under "[UEFI BIOS](#)" on [page 54](#) for this setting. The default setting is **Last State**.

1.4 System Health Monitoring

Onboard Voltage Monitors

An onboard voltage monitor will continuously scan the voltages of the onboard chipset, memory, processor, and battery. Once a voltage becomes unstable, a warning is given or an error message is sent to the screen. You can adjust the voltage thresholds to define the sensitivity of the voltage monitor. Real time voltage levels are displayed in IPMI.

Fan Status Monitor with Firmware Control

The system health monitor embedded in the BMC chip can check the RPM status of the cooling fans. The processor and chassis fans are controlled via IPMI.

Environmental Temperature Control

System Health sensors in the BMC monitor the temperatures and voltage settings of onboard processors and the system in real time via the IPMI interface. Whenever the temperature of the processor or the system exceeds a user-defined threshold, system/processor cooling fans will be turned on to prevent the processor or the system from overheating.

Note: To avoid possible system overheating, be sure to provide adequate airflow to your system.

1.5 ACPI Features

ACPI stands for Advanced Configuration and Power Interface. The ACPI specification defines a flexible and abstract hardware interface that provides a standard way to integrate power management features throughout a computer system, including its hardware, operating system, and application software. This enables the system to automatically turn on and off peripherals such as network cards, hard disk drives, and printers.

In addition to enabling operating system-directed power management, ACPI also provides a generic system event mechanism for Plug and Play, an operating system-independent interface for configuration control. ACPI leverages the Plug and Play BIOS data structures while providing a processor architecture-independent implementation that is compatible with Windows Server 2025.

Chapter 2:

Component Installation

This chapter provides instructions on installing and replacing main system components for the BH4SRG motherboard. To prevent compatibility issues, only use components that match the specifications and/or part numbers given.

Installation or replacement of most components require that power first be removed from the system. Follow the procedures given in each section.

2.1 Static-Sensitive Devices	24
Precautions	24
Unpacking	24
Motherboard Installation	24
Tools Needed	25
Installing the Motherboard	25
2.2 Processor and Heatsink Installation	27
The AMD EPYC™ 4004 and 4005 Series Desktop Processor	27
Overview of the Processor Socket	28
Overview of the Heatsink	28
Installing the Processor	29
Installing the Heatsink	31
2.3 Memory Support and Installation	33
Memory Support	33
General Guidelines for Optimizing Memory Performance	33
DIMM Installation	34
DIMM Removal	36
2.4 Battery Removal and Installation	38
Battery Removal	38
Proper Battery Disposal	38
Battery Installation	38
2.5 Connections, Jumpers, and LEDs	39
Power Supply and Power Connections	39
Headers and Connections	39

Front Control Panel Board and I/O Connector	41
Jumper Settings	42
LED Indicators	44

2.1 Static-Sensitive Devices

Electrostatic Discharge (ESD) can damage electronic components. To avoid damaging your motherboard, it is important to handle it very carefully. The following measures are generally sufficient to protect your equipment from ESD.

Precautions

- Use a grounded wrist strap designed to prevent static discharge.
- Touch a grounded metal object before removing the board from the antistatic bag.
- Handle the motherboard only by its edges. Do not touch its components, peripheral chips, memory modules, or gold contacts.
- When handling chips or modules, avoid touching their pins.
- Put the motherboard and peripherals back into their antistatic bags when not in use.
- For grounding purposes, make sure that your computer chassis provides excellent conductivity between the power supply, the case, the mounting fasteners, and the motherboard.
- Use only the correct type of onboard CMOS battery. To avoid possible explosion, do not install the onboard battery upside down.

Unpacking

To avoid static damage, the motherboard is shipped in antistatic packaging. When unpacking the motherboard, make sure that the person handling it is static protected.

Motherboard Installation

All motherboards have standard mounting holes to fit different types of chassis. Make sure that the locations of all the mounting holes for both the motherboard and the chassis match. Although a chassis may have both plastic and metal mounting fasteners, metal ones are highly recommended because they ground the motherboard to the chassis. Make sure that the metal standoffs click in or are screwed in tightly.

Tools Needed

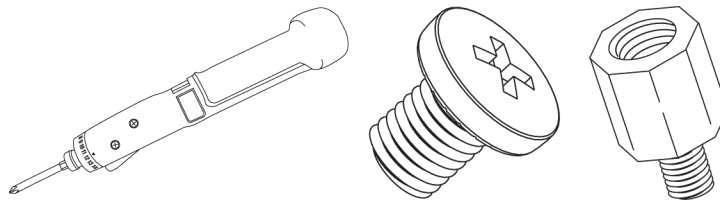

Figure 2-1. BH4SRG Torque Driver (1), Phillips Screws (6), Standoffs (6, only if needed).

Notes:

- To avoid damaging the motherboard and its components, do not use a force greater than 8 lbf-in on each mounting screw during motherboard installation.
- Some components are very close to the mounting holes. Take precautionary measures to avoid damaging these components when installing the motherboard to the chassis.

Installing the Motherboard

1. Locate the mounting holes on the motherboard and the mounting tray.

For a detailed diagram of the BH4SRG motherboard, see the layout under "[Quick Reference](#)" on page 11.

2. Install the standoffs on the mounting tray. Align the mounting holes on the motherboard against the mounting holes on the tray

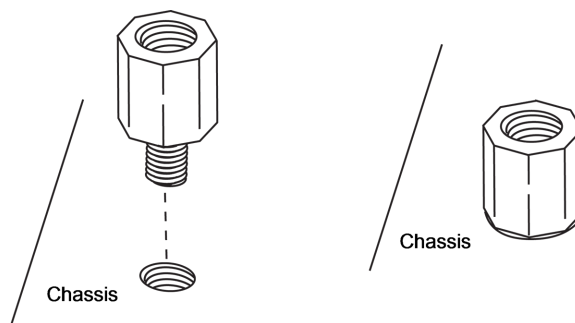

Figure 2-2. Locating the Mounting Holes

3. Using a T20 bit torque driver, set at 12.5–15.0 kgf-cm (10.8–13.0 lbf-in) to prevent damage to the processor, insert a Phillips head #6 screw into the mounting hole on the motherboard and its matching hole on the tray.

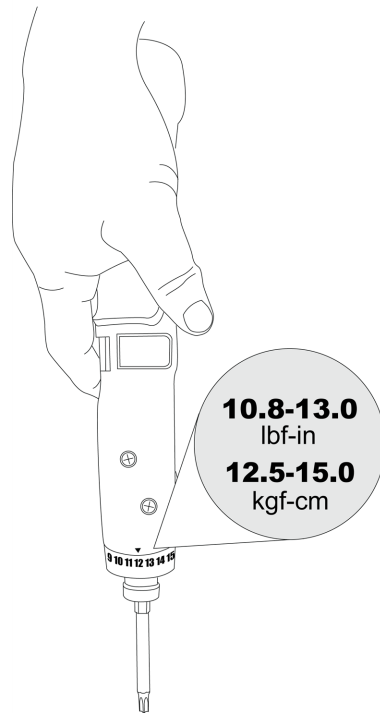

Figure 2-3. Torque Driver Settings

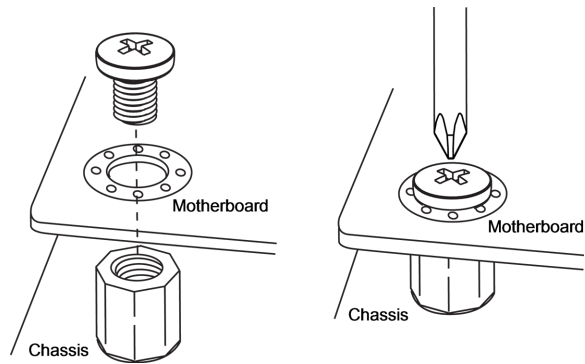

Figure 2-4. Aligning the Mounting Holes

4. Repeat Step 3 to insert #6 screws to all mounting holes located on the motherboard and the tray to securely install the motherboard onto the tray

2.2 Processor and Heatsink Installation

This section provides procedures to install the processor(s) and heatsink(s).

Notes:

- Take industry standard precautions to avoid ESD damage. For details, see "[Static-Sensitive Devices](#)" on page 24.
- Before starting, make sure that the plastic socket cap is in place and none of the socket pins are bent. If any damage is noted, contact your retailer.
- Do not connect the system power cord before the processor and heatsink installation is complete.
- When handling the processor, avoid touching or placing direct pressure on the LGA lands (gold contacts). Improper installation or socket misalignment can cause serious damage to the processor or processor socket.
- Install the processor in the socket and the motherboard into the chassis before installing the heatsink.
- When buying a processor separately, use only a Supermicro certified heatsink.
- Refer to the Supermicro website for the most recent processor support.
- When installing the heatsink, ensure a torque driver set to the correct force is used for each screw.
- Thermal grease is pre-applied on a new heatsink. No additional thermal grease is needed.

The AMD EPYC™ 4004 and 4005 Series Desktop Processor

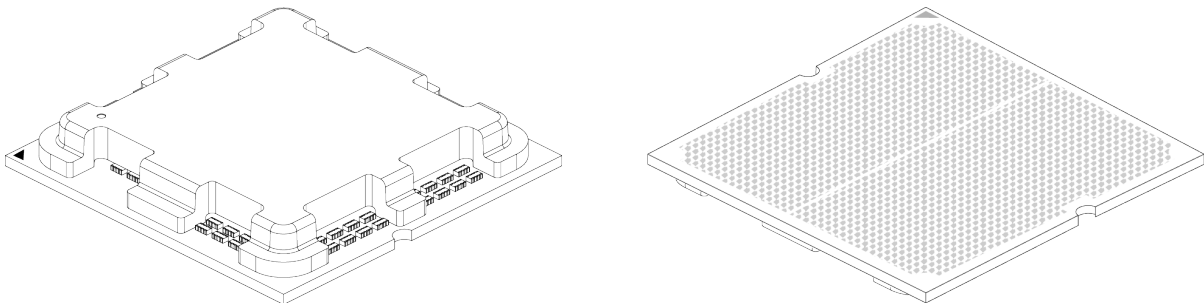

Figure 2-5. Processor

Overview of the Processor Socket

The processor socket is protected by an outer plastic protective cover.

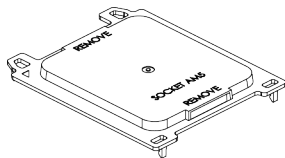

Figure 2-6. Outer Plastic Cover

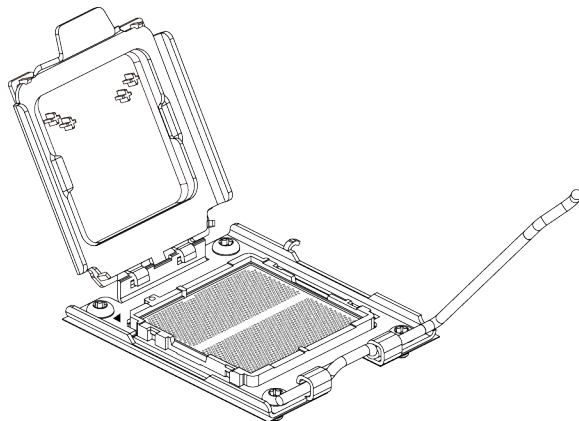

Figure 2-7. AM5 Socket

Overview of the Heatsink

The heatsink (SNK-P0094AP4) is attached to the socket with Phillips #1 screws after the processor is secured. If this is a new heatsink, thermal grease is pre-applied.

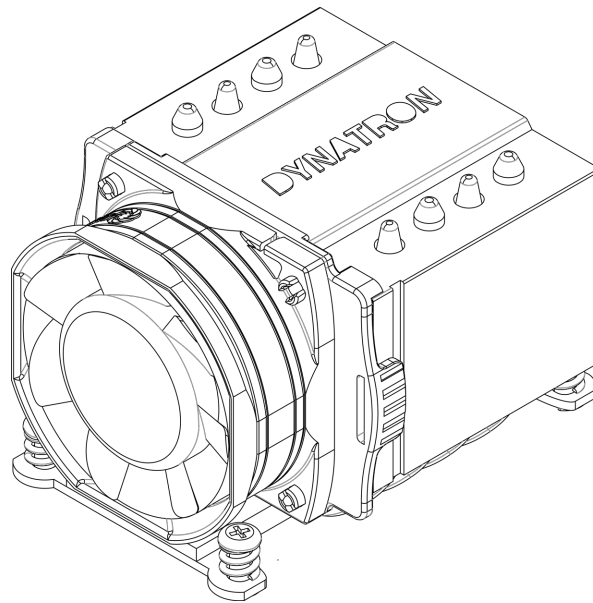

Figure 2-8. 2U Heatsink

Installing the Processor

Note: Do not remove the plastic cover covering the outside of the socket. This cover will pop out during the installation of the processor

1. Use a finger to push down the lever, then move the lever rightward. Pull the lever until it passes over the processor socket.

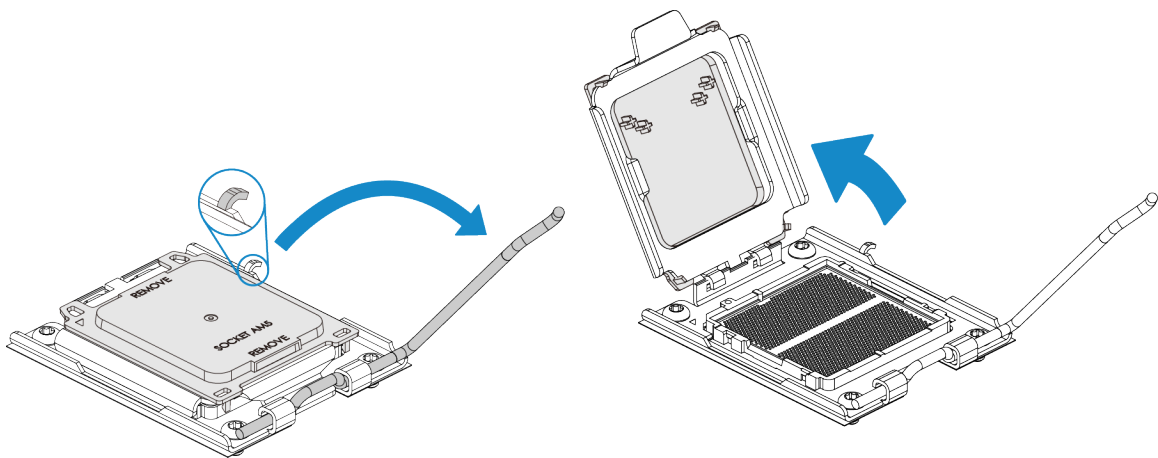

Figure 2-9. Open Load Plate

2. Pick up the processor on its left and right edges. Hold the processor over the socket and align the arrow on the top-left corner of the processor with the arrow on the top-left corner of the socket. Gently lower it onto the AM5 socket pins.

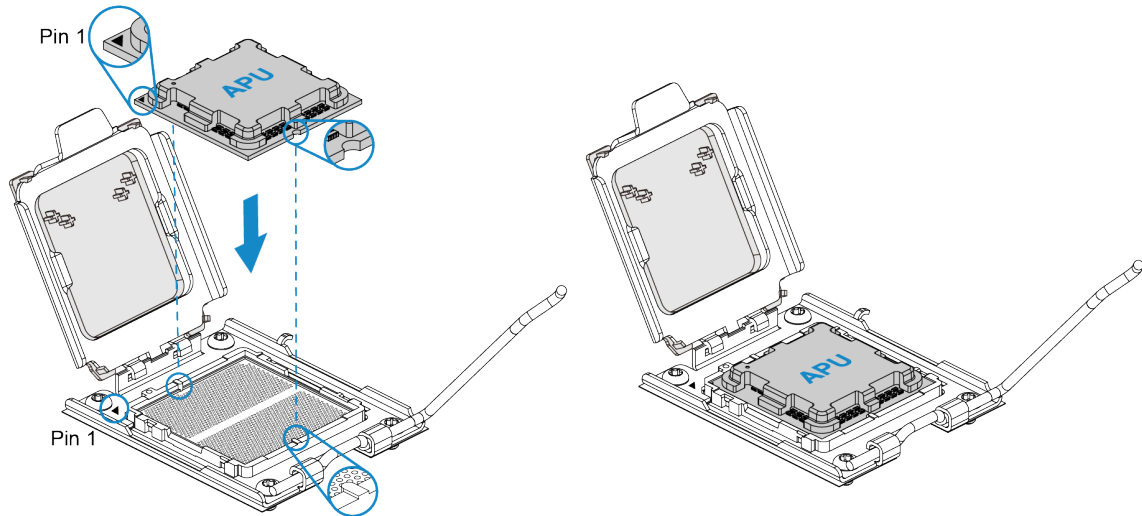

Figure 2-10. Processor in the Socket

3. With the processor in the socket, lower the socket force frame.

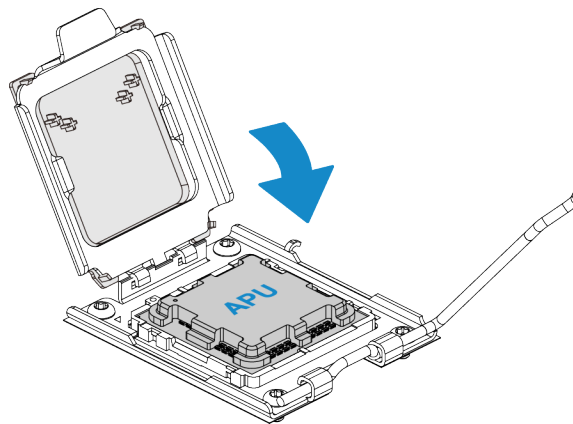

Figure 2-11. Lower the Socket Frame

4. Reattach the lever arm onto the right side of the socket. The outer plastic cover will pop out when the lever arm is reattached.

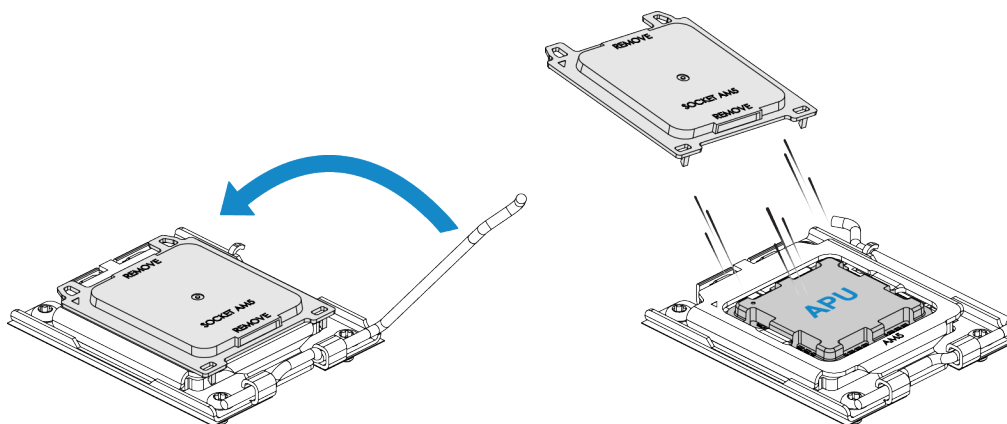

Figure 2-12. Reattach Lever

5. When finished, the socket force frame will secure the processor.

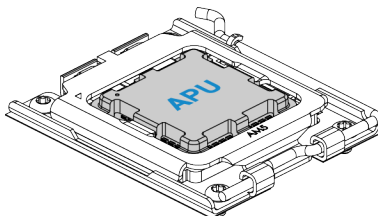

Figure 2-13. Processor in the Socket

Installing the Heatsink

1. After the processor is secured, now you must install the heatsink to the socket frame. Lower the heatsink down until the four screws on the heatsink align with the four screw holes on the socket frame.
2. Using a diagonal pattern, tighten the four screws down on the heatsink. The heatsink will now be secured and you have finished installing the processor and heatsink onto the motherboard. When finished, the heatsink will be secured over the socket and processor.

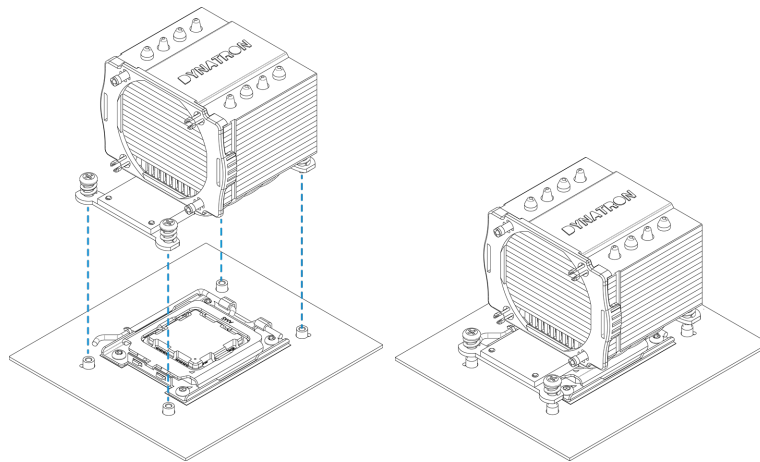

Figure 2-14. Processor with 2U Heatsink

3. Install the heatsink cooling fan and holder assembly on the heatsink body.

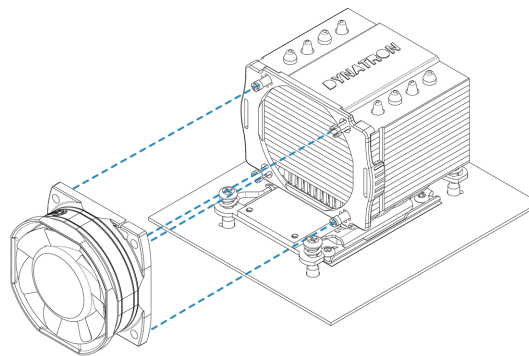

Figure 2-15. Heatsink with Fan

4. Connect cooling fan connector to the fan header labeled for CPU on the motherboard.

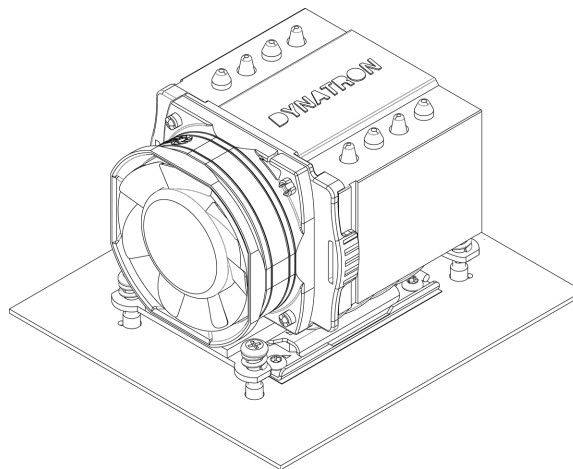

Figure 2-16. Heatsink

2.3 Memory Support and Installation

Important: To prevent any damage, exercise extreme care when installing or removing memory modules.

Note: Check the Supermicro website for recommended memory modules.

Memory Support

The BH4SRG motherboard supports up to 192 GB of ECC and Non-ECC DDR5 UDIMM memory with speeds of up to 5600 MT/s in two DIMM slots or up to 3600 MT/s in four DIMM slots.

Four DIMM Slots							
Channel	DIMM Slot	DIMM Configuration and Maximum Memory Speed (MT/s)					
		1	2	3	4	5	6
Channel A	DIMMA1					Up to 3600 MT/s	Up to 3600 MT/s
	DIMMA2	Up to 5600 MT/s		Up to 5600 MT/s		Up to 3600 MT/s	Up to 3600 MT/s
Channel B	DIMMB1				Up to 3600 MT/s		Up to 3600 MT/s
	DIMMB2		Up to 5600 MT/S	Up to 5600 MT/s	Up to 3600 MT/s		Up to 3600 MT/s

General Guidelines for Optimizing Memory Performance

- The blue slot must be populated first.
- It is recommended to use DDR5 memory of the same type, size, and speed.
- Mixed DIMM speeds can be installed. However, all DIMMs will run at the speed of the slowest DIMM.

- The motherboard will not support an odd-numbered amount of DIMM modules except for a single DIMM module necessary for board operation.

DIMM Installation

Important: To avoid causing any damage to the memory module or the DIMM socket, do not use excessive force when pressing the release tabs on the ends of the DIMM socket. Handle memory modules with care. To avoid ESD-related damage to your memory modules or components, carefully follow all the instructions given in "[Static-Sensitive Devices](#)" on [page 24](#).

1. Insert DIMM modules in the following order: DIMMA2, DIMMB2, then DIMMA1, DIMMB1, and insert the desired number of DIMMs into memory slots based on the recommended DIMM population table earlier in this section. For the system to work properly, use memory modules of the same type and speed.
2. Push the release tabs outwards on both ends of the DIMM slot to unlock it.

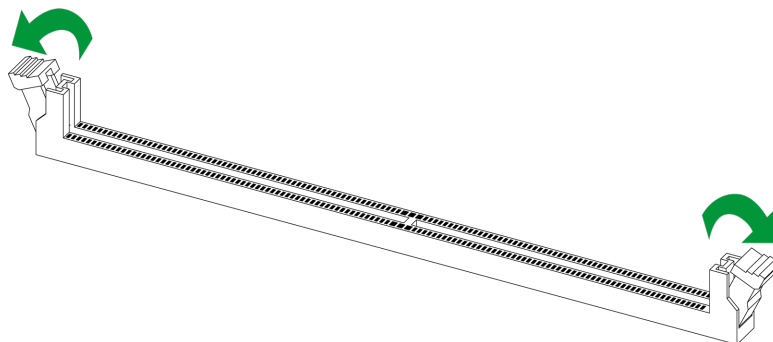

Figure 2-17. Unlocking the DIMM Slot

3. Align the key of the DIMM with the receptive point on the memory slot.

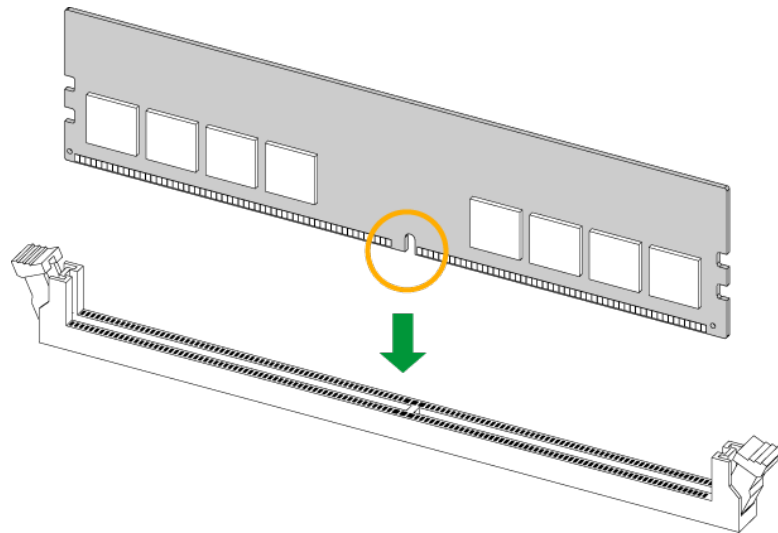

Figure 2-18. Aligning the DIMM Slot with the Receptive Point

4. Align the notches on both ends of the module against the receptive points on the ends of the slot.

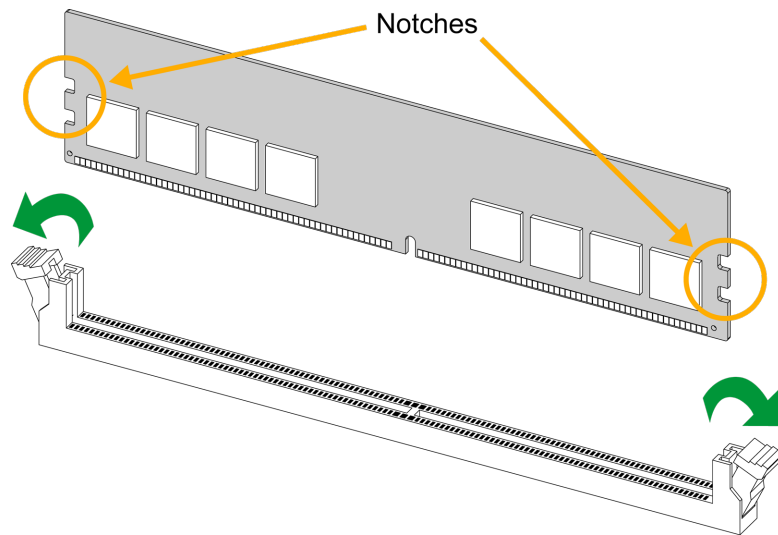

Figure 2-19. Aligning the Notches

5. Press both ends of the module straight down into the slot until the module snaps into place.
6. Press the release tabs to the lock positions to secure the DIMM into the slot.

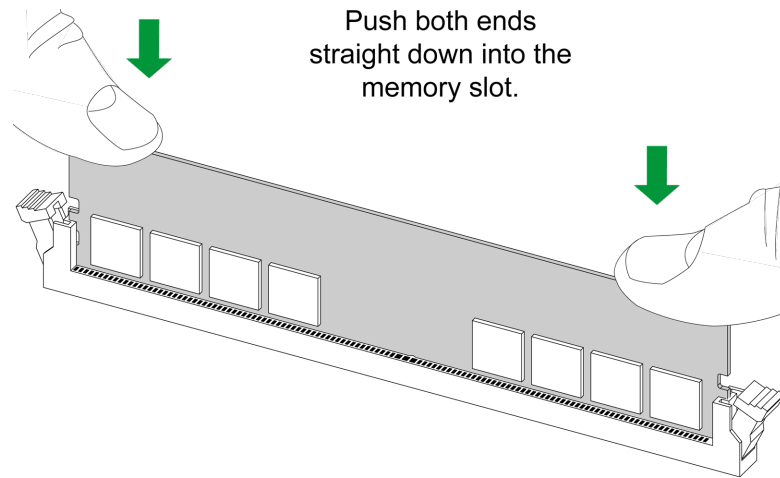

Figure 2-20. Securing the DIMM

For a detailed diagram of the BH4SRG motherboard, see the layout under ["Quick Reference"](#) on page 11.

DIMM Removal

Important: To avoid causing any damage to the memory module or the DIMM socket, do not use excessive force when pressing the release tabs on the ends of the DIMM socket. Handle memory modules with care. To avoid ESD-related damage to your memory modules or components, carefully follow all the instructions given in ["Static-Sensitive Devices"](#) on page 24.

Press both release tabs on the ends of the DIMM socket to unlock it. Once the DIMM is loosened, remove it from the memory slot.

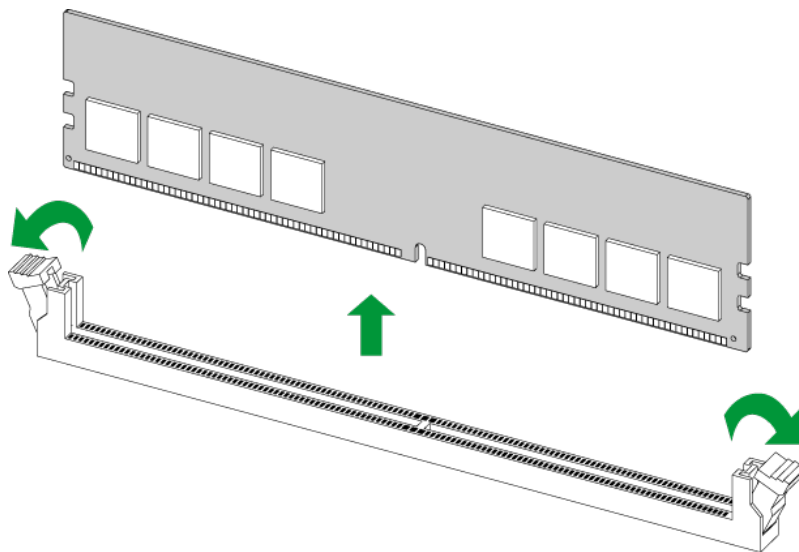

Figure 2-21. Unlocking the DIMM Slot

For a detailed diagram of the BH4SRG motherboard, see the layout under "[Quick Reference](#)" on page 11.

2.4 Battery Removal and Installation

Battery Removal

To remove the onboard battery, follow the steps below:

1. Power off your system and unplug your power cable.
2. Place the system on a workbench.
3. Remove the top cover from the system.
4. Locate the onboard battery as shown below.
5. Using a tool such as a pen or a small screwdriver, push the battery lock outwards to unlock it. Once unlocked, the battery will pop out from the holder.
6. Remove the battery.

Proper Battery Disposal

Important: Handle used batteries carefully. Do not damage the battery in any way; a damaged battery may release hazardous materials into the environment. Do not discard a used battery in the garbage or a public landfill. Comply with the regulations set up by your local hazardous waste management agency to dispose of your used battery properly.

Battery Installation

To install an onboard battery, follow steps 1 and 2 above and continue below:

Important: When replacing a battery, be sure to only replace it with the same type.

1. Identify the battery's polarity. The positive (+) side should be facing up.
2. Insert the battery into the battery holder and push it down until you hear a click to ensure that the battery is securely locked.

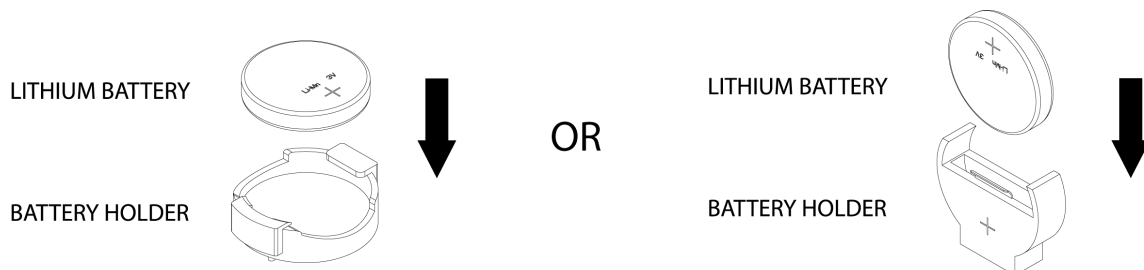

Figure 2-22. Installing a Battery

2.5 Connections, Jumpers, and LEDs

Refer to the following sections for information about connections, jumpers, and LEDs for the BH4SRG motherboard.

Power Supply and Power Connections

For information about the power supply and power connections of the BH4SRG motherboard, refer to the following content.

Power Connector

JPW1 is the +12 V output power connector for the riser cable.

8-pin Power Connector	
Pin Definitions: Eight Total	
Pin#	Definition
1–4	GND
5–6	+12 V (12 V Power)
7–8	+5 V (5 V Power)

Power Supply

As with all computer products, a stable power source is necessary for proper and reliable operation. It is even more important for processors that have high CPU clock rates where noisy power transmission is present.

It is strongly recommended that you use a high quality power supply that meets ATX power supply Specification 2.02 or above. It must also be SSI compliant.

Headers and Connections

For information about the headers on the BH4SRG motherboard, refer to the following content.

M.2 M-Key PCIe 5.0 x2 Slot

The M.2 M-key slot on the motherboard, located at JMD2, supports PCIe 5.0 x2 devices in a 2280/22110 form factor.

For a detailed diagram of the BH4SRG motherboard, see the layout under ["Quick Reference" on page 11](#).

M.2 M-Key PCIe 5.0 x4 Slot

The M.2 M-key slot on the motherboard, located at JMD1, supports PCIe 5.0 x4 devices in a 2280/22110 form factor.

For a detailed diagram of the BH4SRG motherboard, see the layout under ["Quick Reference" on page 11](#).

MCIO PCIe 5.0 x8 Connectors

Mini Cool Edge IO (MCIO) PCIe 5.0 x8 connectors are located at JMCO1 and JMCO2 on the BH4SRG motherboard.

For a detailed diagram of the BH4SRG motherboard, see the layout under ["Quick Reference" on page 11](#).

Power Distributor Board Sideband Signal Header

The power distributor board sideband signal header, located at J6 on the BH4SRG motherboard, monitors the power distributor board (PDB).

For a detailed diagram of the BH4SRG motherboard, see the layout under ["Quick Reference" on page 11](#).

System Cooling Fan Header

There is one 4-pin fan header located at FAN1 on the motherboard.

For a detailed diagram of the BH4SRG motherboard, see the layout under ["Quick Reference" on page 11](#).

4-pin Fan Header	
Pin Definitions: Four Total	
Pin#	Definition
1	GND (Black)
2	+12 V (Red)
3	TACH
4	PWM

Trusted Platform Module

The JTPM1 header on the BH4SRG motherboard is used to connect a Trusted Platform Module (TPM), which is available from Supermicro (optional). A TPM connector is a security device that supports encryption and authentication in storage drives. It allows the motherboard to deny access if the TPM associated with the storage drive is not installed in the system. Information on the TPM is available at the following page:

https://www.supermicro.com/manuals/other/AOM-TPM-9670V_9670H_X12_H12.pdf

For a detailed diagram of the BH4SRG motherboard, see the layout under "Quick Reference" on page 11.

Trusted Platform Module Header			
Pin Definitions: 10 Total			
Pin#	Definition	Pin#	Definition
1	+3.3 V	2	SPI_CS#
3	RESET#	4	SPI_MISO
5	SPI_CLK	6	Ground
7	SPI_MOSI	8	No Connection
9	+1.8 V Standby	10	SPI_IRQ#

Front Control Panel Board and I/O Connector

Refer to the following content for information about the front control board and the I/O connector on the BH4SRG motherboard.

Front Control Panel Connector

The connector for the Front Control Panel board, located at JFP1 on the BH4SRG motherboard, contains various header pins and LED indications for front access through an appropriate cable.

Button or LED	Function	State	Description
	Power Button	N/A	Turns the blade module on and off.
	Power LED	Green Solid Orange Flashing Orange	Indicates power status "On." Indicates power status "Off" with power cables plugged in. Indicates the node is not ready or does not have enough power to turn on.
	KVM/UID LED	Blue Flashing Blue	Indicates the KVM is in use by the blade unit. Indicates UID is activated on the blade module.

Button or LED	Function	State	Description
	Network/IB LED	Flashing Green Flashing Orange	Indicates network activity over LAN. Indicates network activity over the Infiniband module.
	System Fault LED	Red	Indicates that a memory error, overheat, VGA error, or any other error prevents booting.

(missing or bad snippet)

Jumper Settings

To modify the operation of the motherboard, jumpers can be used to choose between optional settings. Jumpers create shorts between two pins to change the function of the connector. Pin 1 is identified with a square solder pad on the printed circuit board. See the diagram below for an example of jumping pins 1 and 2. Refer to the motherboard layout page for jumper locations.

Note: On two-pin jumpers, "Closed" means the jumper is on and "Open" means the jumper is off the pins.

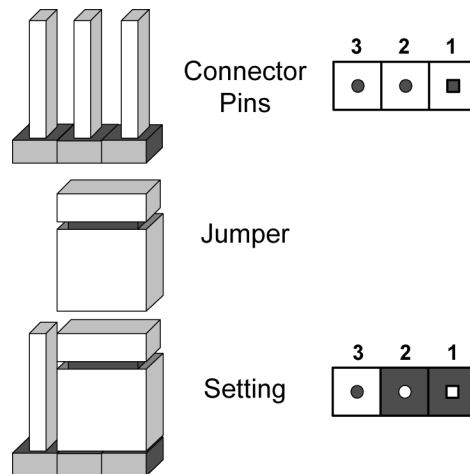

Figure 2-23. Jumping Connector Pins

CMOS Clear

JBT1 on the BH4SRG motherboard is used to clear CMOS, which will also clear any passwords. Instead of pins, this jumper consists of contact pads to prevent accidentally clearing the contents of CMOS.

For a detailed diagram of the BH4SRG motherboard, see the layout under ["Quick Reference" on page 11](#).



1. First power down the system and unplug the power cord(s).
2. Remove the cover of the chassis to access the motherboard.
3. Remove the onboard battery from the motherboard.
4. Short the CMOS pads, JBT1, with a metal object such as a small screwdriver for at least four seconds.

Note: Clearing CMOS will also clear all passwords.

5. Remove the screwdriver (or shorting device).
6. Replace the cover, reconnect the power cord(s), and power on the system.

Onboard TPM Enable/Disable

Use JPT1 to enable or disable the onboard TPM.

For a detailed diagram of the BH4SRG motherboard, see the layout under ["Quick Reference" on page 11](#).

TPM Enable/Disable	
Jumper Settings	
Jumper Setting	Definition
Pins 1–2	Enabled (Default)
Pins 2–3	Disabled

VGA Enable/Disable

Jumper JPG1 allows you to enable the onboard VGA signal on the BH4SRG motherboard. The default setting is pins 1–2 to enable the connection.

For a detailed diagram of the BH4SRG motherboard, see the layout under ["Quick Reference" on page 11](#).

VGA Enable/Disable	
Jumper Settings	
Jumper Setting	Definition
Pins 1–2	Enabled (Default)
Pins 2–3	Disabled

Watchdog Timer

Watchdog (JWD1) is a system monitor that can reboot the system when a software application hangs. Close pins 1–2 to reset the system if an application hangs. Close pins 2–3 to generate a non-maskable interrupt (NMI) signal for the application that hangs. The Watchdog must also be enabled in the BIOS.

For a detailed diagram of the BH4SRG motherboard, see the layout under "[Quick Reference](#)" on page 11.

Watchdog Timer	
Jumper Settings	
Jumper Setting	Definition
Pins 1–2	Reset (Default)
Pins 2–3	NMI
Open	Disabled

LED Indicators

For information about the LED indicators on the BH4SRG motherboard, refer to the following content.

BMC Heartbeat LED

A BMC Heartbeat LED is located on the BH4SRG motherboard. When this LED is blinking, the BMC is functioning normally.

For a detailed diagram of the BH4SRG motherboard, see the layout under "[Quick Reference](#)" on page 11.

BMC Heartbeat LED Indicator	
LED Color	Definition
Green: Blinking	BMC Normal

Chapter 3:

Troubleshooting

The following content contains information on common issues and how to resolve them.

3.1 Troubleshooting Procedures	46
Before Power On	46
No Power	46
No Video	46
System Boot Failure	46
Memory Errors	47
Losing the System's Setup Configuration	47
If the System Becomes Unstable	47
3.2 Technical Support Procedures	49
3.3 Motherboard Battery	50
3.4 Where to Get Replacement Components	51
3.5 Returning Merchandise for Service	52
3.6 Feedback	53

3.1 Troubleshooting Procedures

Use the following procedures to troubleshoot your system. If you have followed all of the procedures below and still need assistance, refer to the ["Technical Support Procedures" on page 49](#) or ["Returning Merchandise for Service" on page 52](#) section(s) in this chapter. Always disconnect the AC power cord before adding, changing or installing any non hot-swap hardware components. If the below steps do not fix the setup configuration problem, contact your vendor for repairs.

Before Power On

1. Make sure that there are no short circuits between the motherboard and chassis.
2. Disconnect all ribbon/wire cables from the motherboard, including those for the keyboard and mouse.
3. Remove all add-on cards.
4. Install the processor (making sure it is fully seated) and connect the front panel connectors to the motherboard.

No Power

1. Make sure that there are no short circuits between the motherboard and the chassis.
2. Make sure that the power connectors are properly connected.
3. Check that the 115 V/230 V switch, if available, on the power supply is properly set.
4. Turn the power switch on and off to test the system, if applicable.
5. Check the processor socket for bent pins and make sure the processor is fully seated.
6. The battery on your motherboard may be old. Check to verify that it still supplies approximately 3 VDC. If it does not, replace it with a new one.

No Video

1. If the power is on, but you do not have video, remove all add-on cards and cables.
2. Remove all memory modules and turn on the system (if the alarm is on, check the specs of memory modules, reset the memory, or try a different one).

System Boot Failure

If the system does not display Power-On-Self-Test (POST) or does not respond after the power is turned on, do the following:

1. Check the screen for an error message.
2. Clear the CMOS settings by unplugging the power cord and contacting both pads on the CMOS clear jumper. Restart the system. Refer to ["CMOS Clear" on page 42](#).
3. Remove all components from the motherboard and turn on the system with only one DIMM installed. If the system boots, turn off the system and repopulate the components back into the system to retest. Add one component at a time to isolate which one may have caused the system boot issue.

Memory Errors

When suspecting faulty memory is causing the system issue, check the following:

1. Make sure that the memory modules are compatible with the system and are properly installed. See ["Component Installation" on page 22](#) for installation instructions. (For memory compatibility, refer to the "Tested Memory List" link on the motherboard's product page to see a list of supported memory.)
2. Check if different speeds of DIMMs have been installed. It is strongly recommended that you use the same RAM type and speed for all DIMMs in the system.
3. Make sure that you are using the correct type of DIMMs recommended by the manufacturer.
4. Check for bad DIMMs or slots by swapping a single module among all memory slots and check the results.

Losing the System's Setup Configuration

1. Make sure that you are using a high-quality power supply. A poor-quality power supply may cause the system to lose the CMOS setup information. Refer to ["Introduction" on page 10](#) for details on recommended power supplies.
2. The battery on your motherboard may be old. Check to verify that it still supplies approximately 3 VDC. If it does not, replace it with a new one.

If the System Becomes Unstable

If the system becomes unstable during or after OS installation, check the following:

1. Processor/BIOS support: Make sure that your processor is supported and that you have the latest BIOS installed in your system.

2. Memory support: Make sure that the memory modules are supported. Refer to the product page on our website at <https://www.supermicro.com>. Test the modules using memtest86 or a similar utility.

Note: Click on the "Tested Memory List" link on the motherboard's product page to see a list of supported memory.

3. Storage Drive support: Make sure that all storage drives work properly. Replace the failed storage drives with good ones.
4. System cooling: Check the system cooling to make sure that all heatsink fans and processor/system fans, etc., work properly. Check the hardware monitoring settings in the IPMI to make sure that the processor and system temperatures are within the normal range. Also, check the front panel Overheat LED and make sure that it is not on.
5. Adequate power supply: Make sure that the power supply provides adequate power to the system. Make sure that all power connectors are connected. Refer to our website for more information on the minimum power requirements.
6. Proper software support: Make sure that the correct drivers are used.

If the system becomes unstable before or during OS installation, check the following:

1. Source of installation: Make sure that the devices used for installation are working properly, including boot devices such as a USB flash or media device.
2. Cable connection: Check to make sure that all cables are connected and working properly.
3. Use the minimum configuration for troubleshooting: Remove all unnecessary components (starting with add-on cards first), and use the minimum configuration (but with the processor and a memory module installed) to identify the trouble areas. Refer to the steps listed above in this section for proper troubleshooting procedures.
4. Identify bad components by isolating them: If necessary, remove a component in question from the chassis, and test it in isolation to make sure that it works properly. Replace a bad component with a good one.
5. Check and change one component at a time instead of changing several items at the same time. This will help isolate and identify the problem.
6. To find out if a component is good, swap this component with a new one to see if the system will work properly. If so, then the old component is bad. You can also install the component in question in another system. If the new system works, the component is good and the old system has problems.

3.2 Technical Support Procedures

Before contacting Technical Support, take the following steps. Also, note that as a motherboard manufacturer, Supermicro also sells motherboards through its channels, so it is best to first check with your distributor or reseller for troubleshooting services. They should know of any possible problems with the specific system configuration that was sold to you.

1. Refer to "Troubleshooting Procedures" on page 46 or see the FAQs on our website (<https://www.supermicro.com/FAQ/index.php>) before contacting Technical Support.
2. BIOS upgrades can be downloaded from our website (https://www.supermicro.com/support/resources/bios_ipmi.php).
3. If you still cannot resolve the problem, include the following information when contacting Supermicro for technical support:
 - Motherboard model and PCB revision number
 - BIOS release date/version (This can be seen on the initial display when your system first boots up.)
 - System configuration
4. An example of a Technical Support form is on our website at <https://webpr3.supermicro.com/SupportPortal>.
5. Distributors: For immediate assistance, have your account number ready when placing a call to our Technical Support department. For Supermicro contact information, refer to "Contacting Supermicro" on page 9.

3.3 Motherboard Battery

For information on removing, disposing of, and replacing the motherboard battery of your system, refer to ["Battery Removal and Installation"](#) on page 38.

3.4 Where to Get Replacement Components

If you need replacement parts for your BH4SRG motherboard, to ensure the highest level of professional service and technical support, purchase exclusively from our Supermicro Authorized Distributors/System Integrators/Resellers. A list can be found on the Supermicro website:

<https://www.supermicro.com>

Under the "Buy" menu, click the "Where to Buy" link.

3.5 Returning Merchandise for Service

A receipt or copy of your invoice marked with the date of purchase is required before any warranty service will be rendered. You can obtain service by calling your vendor for a Returned Merchandise Authorization (RMA) number. When returning the motherboard to the manufacturer, the RMA number should be prominently displayed on the outside of the shipping carton, and the shipping package is mailed prepaid or hand-carried. Shipping and handling charges will be applied for all orders that must be mailed when service is complete.

For faster service, RMA authorizations can be requested online at the following page:

<https://www.supermicro.com/RmaForm>

Whenever possible, repack the motherboard in the original Supermicro carton, using the original packaging material. If these are no longer available, be sure to pack the motherboard securely, using packaging material to surround the motherboard so that it does not shift within the carton and become damaged during shipping.

This warranty only covers normal consumer use and does not cover damages incurred in shipping or from failure due to the alternation, misuse, abuse or improper maintenance of products.

During the warranty period, contact your distributor first for any product problems.

3.6 Feedback

Supermicro values your feedback as we strive to improve our customer experience in all facets of our business. Email us at Techwriterteam@supermicro.com to provide feedback on our manuals.

Chapter 4:

UEFI BIOS

The following content contains information on BIOS configuration with the BH4SRG motherboard.

4.1 Introduction	55
4.2 Main Setup	56
4.3 Advanced Setup Configurations	58
4.4 BMC	79
4.5 Security	83
4.6 Boot	87
4.7 Save & Exit	89

4.1 Introduction

This chapter describes the AMIBIOS™ Setup utility for the motherboard. The BIOS is stored on a chip and can be easily upgraded using the UEFI script (flash.nsh), the BMC WebUI, or the SuperServer Automation Assistant (SAA) utility.

Note: Due to periodic changes to the BIOS, some settings may have been added or deleted and might not yet be recorded in this manual. Refer to the Manual Download area of our website for any changes to BIOS that may not be reflected in this manual.

Starting the Setup Utility

To enter the BIOS Setup utility, press the <Delete> key while the system is booting-up. In most cases, the <Delete> key is used to invoke the BIOS Setup screen. There are a few cases when other hot keys are used, such as <F1>, <F2>, etc. Each main BIOS menu option is described in this manual.

The Main BIOS screen has two main frames. The left frame displays all the options that can be configured. “Grayed-out” options cannot be configured. The right frame displays the key legend. Above the key legend is an area reserved for a text message. When a BIOS submenu or item is selected in the left frame, it is highlighted in white. Often a text message will accompany it. (Note that BIOS has default text messages built in. We retain the option to include, omit, or change any of these text messages.) Settings printed in Bold are the default values.

A "►" indicates a submenu. Highlighting such an item and pressing the <Enter> key open the list of settings within that submenu.

The BIOS Setup utility uses a key-based navigation system called hot keys. Most of these hot keys (<F1>, <F2>, <F3>, <F4>, <F5>, <F6>, <Enter>, <ESC>, the arrow keys, etc.) can be used at any time during the setup navigation process.

4.2 Main Setup

The Main setup screen appears when the AMI BIOS Setup utility is first entered. To return to the Main setup screen, select the Main tab at the top of the screen. The Main BIOS setup screen is shown below.



Figure 4-1. UEFI BIOS Main Tab Screen

System Date/System Time

Use the two features to change the system date and time. Highlight **System Date** or **System Time** using the arrow keys. Enter new values using the keyboard. Press the <Tab> key or the arrow keys to move between fields. The date must be entered in MM/DD/YYYY format. The time is entered in HH:MM:SS format.

Note: The time is in the 24-hour format. For example, 5:30 P.M. appears as 17:30:00.

Supermicro BH4SRG

BIOS Version

This feature displays the version of the BIOS ROM used in the system.

Build Date

This feature displays the date when the version of the BIOS ROM used in the system was built.

CPLD Version

This feature displays the version of the Complex-Programmable Logical Device (CPLD) used in the system.

Memory Information**Total Memory**

This feature displays the total size of memory available in the system.

4.3 Advanced Setup Configurations

Use the arrow keys to select the Advanced submenu and press <Enter> to access the submenu items.

Important: Use caution when changing the Advanced settings. An incorrect value, an improper DRAM frequency, or a wrong BIOS timing setting may cause the system to malfunction. When this occurs, revert the settings to the default manufacturing settings.

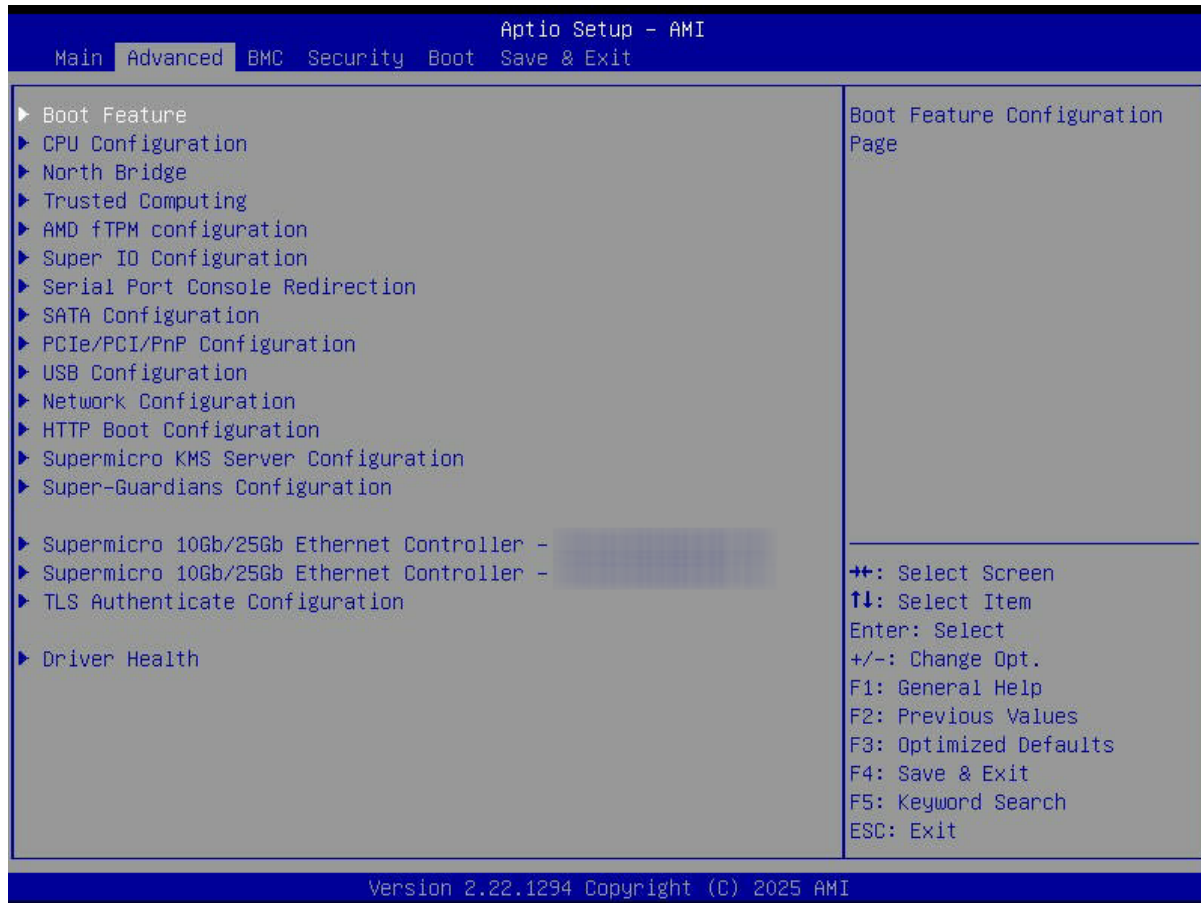

Figure 4-2. Advanced BIOS Screen

Boot Feature Menu

▶ Boot Feature

Quiet Boot

Use this feature to select the screen between displaying the Power-on Self Test (POST) messages or the OEM logo upon bootup. Select Disabled to display the POST messages. Select Enabled to display the OEM logo instead of the normal POST messages. The options

are Disabled and **Enabled**.

Note: BIOS POST messages are always displayed regardless of the setting of this feature.

Option ROM Messages

Use this feature to set the display mode for the Option ROM. Select Keep Current to display the current AddOn ROM display settings. Select Force BIOS to use the Option ROM display mode set by the system BIOS. The options are **Force BIOS** and Keep Current.

Bootup NumLock State

Use this feature to set the Power-on state for the <Numlock> key. The options are **On** and Off.

Wait For "F1" If Error

Select Enabled to force the system to wait until the <F1> key is pressed if an error occurs. The options are Disabled and **Enabled**.

INT19 Trap Response

Interrupt 19 is the software interrupt that handles the boot disk function. When this feature is set to Immediate, the ROM BIOS of the host adaptors will "capture" Interrupt 19 at bootup immediately and allow the drives that are attached to these host adaptors to function as bootable disks. If this feature is set to Postponed, the ROM BIOS of the host adaptors will not capture Interrupt 19 immediately to allow the drives attached to these adaptors to function as bootable devices at bootup. The options are **Immediate** and Postponed.

Re-try Boot

If this feature is set to Enabled, the system BIOS will automatically reboot the system from an Extensible Firmware Interface (EFI) boot device after an initial boot failure. The options are **Disabled** and Enabled.

Power Configuration

Watch Dog Function

Select Enabled to allow the Watch Dog timer to reboot the system when it is inactive for more than five minutes. The options are **Disabled** and Enabled.

Watch Dog Action (Available when "Watch Dog Function" is set to Enabled)

Use this feature to configure the Watch Dog Time_out setting. The options are **Reset** and NMI.

Power Button Function

This feature controls how the system shuts down when the power button is pressed. Select 4 Seconds Override to power off the system after pressing and holding the power button for four seconds or longer. Select Instant Off to instantly power off the system as soon as you press the power button. The options are **Instant Off** and 4 Seconds Override.

CPU Configuration Menu

► CPU Configuration

Module Version:

This feature displays the Module Version.

Global C-state Control

Controls IO based C-state generation and DF C-states. The options are **Disabled**, Enabled, and Auto.

PSS Support

Use this feature to enable or disable the generation of ACPI_PCC, _PSS, and _PCT objects. The options are Disabled and **Enabled**.

PPC Adjustment (Available when PSS Support is set to "Enabled")

Use this feature to adjust _PPC, the PState object. The options are **PState 0** and PState 1.

NX Mode

Use this feature to enable or disable the No Execute (NX) page protection function. When this feature is Disabled, execution of code in memory pages will be prevented. The options are Disabled and **Enabled**.

SVM Mode

This setting enables or disables CPU Virtualization. The options are Disabled and **Enabled**.

SMT Control

This setting is used to disable symmetric multithreading. To re-enable SMT, a power cycle is needed after selecting the Enable option. Select Auto based on BIOS PCD default setting. The options are Disabled, Enabled, and **Auto**.

Core Performance Boost

Use this setting to configure Core Performance Boost. The options are Disabled and **Auto**.

► CPU Information

This feature displays general information about the CPU installed on the motherboard.

The following information is displayed:

- Socket0:
- Core(s) Running @ MHz and mV

- Processor Family:
- Processor Model:
- CPUID:
- Max Speed:
- Min Speed:
- Microcode Patch Level:

----- Cache per core -----

- L1 Instruction Cache:
- L1 Data Cache:
- L2 Cache:
- Total L3 Cache per Socket:

North Bridge Configuration Menu

North Bridge Configuration

Above 4G MMIO Limit

Use this feature to set the Above 4G MMIO Limit between 38 to 43 bits. This feature works only when "Above 4G Decoding is enabled" under "PCIe/PCI/PnP Conguration." The options are **40bit (1TB)**, 41bit (2TB), 42bit (4TB), 43bit (8TB), 44bit (16TB), 45bit(32TB), 46bit (64TB), 47bit (128TB), and 48bit (256TB).

IOMMU

Use this setting to enable or disable IOMMU. The options are Disabled, Enabled, and **Auto**.

PPT Control

Use this feature to set or disable Package Power Tracking (PPT) Control. The options are Manual and **Auto**.

► Memory Information

The following information is displayed:

- Ending Address
- DIMMA1
- DIMMA2

- DIMMB1
- DIMMB2

Trusted Computing Menu

When a Trusted-Platform Module (TPM) device is detected in your machine, the following information will display:

- TPM 2.0 Device Found
- Firmware Version:
- Vendor:

Security Device Support

If this feature and the TPM jumper on the motherboard are both set to Enabled, onboard security devices will be enabled for Trusted Platform Module (TPM) support to enhance data integrity and network security. Please reboot the system for a change on this setting to take effect. The options are Disabled and **Enabled**.

When "Security Device Support" is set to Enabled and a TPM 2.0 device is detected by the BIOS, the following information is displayed.

- Active PCR banks
- Available PCR banks

Note: The following features are available when a TPM 2.0 device is detected by the BIOS.

SHA256 PCR Bank (Available when "Security Device Support" is set to Enable)

Use this feature to disable or enable the SHA256 Platform Configuration Register (PCR) bank for the installed TPM device to enhance system integrity and data security. The options are Disabled and **Enabled**.

SHA384 PCR Bank (Available when "Security Device Support" is set to Enable)

Select Enabled to enable SHA384 PCR Bank support to enhance system integrity and data security. The options are Enabled and **Disabled**.

Pending Operation

Use this feature to schedule a TPM-related operation to be performed by a security device for system data integrity. The options are **None** and TPM Clear.

Note: Your system will reboot to carry out a pending TPM operation.

Platform Hierarchy (Available when "Security Device Support" is set to Enable)

Select Enabled for TPM Platform Hierarchy support, which allows the manufacturer to use the cryptographic algorithm to define a constant key or a fixed set of keys to be used for initial system boot. These early boot codes are shipped with the platform and are included in the list of "public keys." During system boot, the platform firmware uses the trusted public keys to verify a digital signature in an attempt to manage and control the security of the platform firmware used in a host system via a TPM device. The options are Disabled and **Enabled**.

Storage Hierarchy (Available when "Security Device Support" is set to Enable)

Select Enabled for TPM Storage Hierarchy support that is intended to be used for non-privacy-sensitive operations by a platform owner such as an IT professional or the end user. Storage Hierarchy has an owner policy and an authorization value, both of which can be set and are held constant (rarely changed) through reboots. This hierarchy can be cleared or changed independently of the other hierarchies. The options are Disabled and **Enabled**.

Endorsement Hierarchy (Available when "Security Device Support" is set to Enable)

Select Enabled for Endorsement Hierarchy support, which contains separate controls to address privacy concerns because the primary keys in the hierarchy are certified by the TPM key or by a manufacturer with restrictions on how an authentic TPM device that is attached to an authentic platform can be accessed and used. A primary key can be encrypted and certified with a certificate created by using TPM2_ActivateCredential, which allows you to independently enable "flag, policy, and authorization values" without involving other hierarchies. A user with privacy concerns can disable the endorsement hierarchy while still using the storage hierarchy for TPM applications, permitting the platform software to use the TPM. The options are Disabled and **Enabled**.

PH Randomization

Use this feature to disable or enable Platform Hierarchy (PH) Randomization. The options are **Disabled** and Enabled.

AMD fTPM Configuration

AMD fTPM Switch

Use this feature to setup AMD fTPM. The options are AMD CPU fTPM and **Route to SPI TPM**.

Erase fTPM NV for Factory Reset

When a new CPU is installed, select "Enabled" to reset fTPM. If the system has BitLocker or an encryption-enable system, then the system will not boot without a recovery key. Select "Disabled" to keep the previous fTPM record and continue system boot. fTPM will not be enabled with a new CPU unless fTPM is reset (reinitialized). Swap back to the old CPU to recover TPM related keys and data. The options are Disabled and **Enabled**.

Super IO Configuration Menu

► Super IO Configuration

Note: This submenu is available when your system supports this feature.

The following information is displayed.

- Super IO Chip

Select for Serial Port 1 or Serial Port 2.

Serial Port 1 Configuration Menu

Serial Port 1 Configuration

Serial Port 1

Select Enabled to enable serial port 1. The options are Disabled and **Enabled**.

Device Settings (Available when "Serial Port 1" above is set to Enabled)

This feature displays the base I/O port address and the Interrupt Request address of serial port 1.

Change Settings (Available when "Serial Port 1" above is set to Enabled)

Use this feature to specify the base I/O port address and the Interrupt Request address of serial port 1. Select Auto for the BIOS to automatically assign the base I/O and IRQ address to serial port 1. The options are **Auto**, (IO=3F8h; IRQ=4;), (IO=3F8h; IRQ=3,4,5,6,7,9,10,11,12;), (IO=2F8h; IRQ=3,4,5,6,7,9,10,11,12;), (IO=3E8h; IRQ=3,4,5,6,7,9,10,11,12;), and (IO=2E8h; IRQ=3,4,5,6,7,9,10,11,12;).

Serial Port 2 Configuration Menu

Serial Port 2 Configuration

Serial Port 2/SOL ("Serial Port 2" or "SOL" based on your system support)

Select Enabled to enable serial port 2 (or SOL). The options are Disabled and **Enabled**.

Device Settings (Available when "Serial Port 2/SOL" above is set to Enabled)

This feature displays the base I/O port address and the Interrupt Request address of serial port 2 (or SOL).

Change Settings (Available when "Serial Port 2/SOL" above is set to Enabled)

Use this feature to specify the base I/O port address and the Interrupt Request address of serial port 2 (or SOL). Select Auto for the BIOS to automatically assign the base I/O and IRQ address to serial port 2 (or SOL).

The options are **Auto**, (IO=2F8h; IRQ=3;), (IO=3F8h; IRQ=3,4,5,6,7,9,10,11,12;), (IO=2F8h; IRQ=3,4,5,6,7,9,10,11,12;), (IO=3E8h; IRQ=3,4,5,6,7,9,10,11,12;), and (IO=2E8h; IRQ=3,4,5,6,7,9,10,11,12;).

Serial Port 2 Attribute (Available for Serial Port 2 only)

Select SOL to use serial port 2 as a Serial Over LAN (SOL) port for console redirection. The options are **SOL** and COM.

Serial Port Console Redirection Menu

COM1 (Available when your system supports the serial port of COM1)

Console Redirection

Select Enabled to enable COM port 1 for Console Redirection, which allows a client machine to be connected to a host machine at a remote site for networking. The options are **Disabled** and Enabled.

Note: This feature will be set to Enabled if there is no BMC support.

► Console Redirection Settings

Note: This submenu is available when "Console Redirection" for COM1 or SOL/COM2 is set to Enabled.

Terminal Type

Use this feature to select the target terminal emulation type for Console Redirection. Select VT100 to use the ASCII Character set. Select VT100+ to add color and function key support. Select ANSI to use the Extended ASCII Character Set. Select VT-UTF8 to use UTF8 encoding to map Unicode characters into one or more bytes. The options are VT100, **VT100+**, VT-UTF8, and ANSI.

Bits Per Second

Use this feature to set the transmission speed for a serial port used in Console Redirection. Make sure that the same speed is used in the host computer and the client computer. A lower transmission speed may be required for long and busy lines. The options are 9600, 19200, 38400, 57600, and **115200** (bits per second).

Data Bits

Use this feature to set the data transmission size for Console Redirection. The options are 7 and **8** (bits).

Parity

A parity bit can be sent along with regular data bits to detect data transmission errors. Select Even if the parity bit is set to 0, and the number of 1's in data bits is even. Select Odd if the parity bit is set to 0, and the number of 1's in data bits is odd. Select None if you do not want to send a parity bit with your data bits in transmission. Select Mark to add a mark as a parity bit to be sent along with the data bits. Select Space to add a Space as a parity bit to be sent with your data bits. The options are **None**, Even, Odd, Mark, and Space.

Stop Bits

A stop bit indicates the end of a serial data packet. Select 1 Stop Bit for standard serial data communication. Select 2 Stop Bits if slower devices are used. The options are **1** and 2.

Flow Control

Use this feature to set the flow control for Console Redirection to prevent data loss caused by buffer overflow. Send a "Stop" signal to stop sending data when the receiving buffer is full. Send a "Start" signal to start sending data when the receiving buffer is empty. The options are **None** and Hardware RTS/CTS.

VT-UTF8 Combo Key Support

Select Enabled to enable VT-UTF8 Combination Key support for ANSI/VT100 terminals. The options are Disabled and **Enabled**.

Recorder Mode

Select Enabled to capture the data displayed on a terminal and send it as text messages to a remote server. The options are **Disabled** and Enabled.

Resolution 100x31

Select Enabled for extended-terminal resolution support. The options are Disabled and **Enabled**.

Putty KeyPad

This feature selects Function Keys and KeyPad settings for Putty, which is a terminal emulator designed for the Windows OS. The options are **VT100**, LINUX, XTERMR6, SCO, ESCN, and VT400.

SOL

Console Redirection

Select Enabled to enable the COM port for Console Redirection, which will allow a client machine to be connected to a host machine at a remote site for networking. The options are Disabled and **Enabled**.

► Console Redirection Settings

Note: This submenu is available when "Console Redirection" for COM1 or SOL/COM2 is set to Enabled.

Terminal Type

Use this feature to select the target terminal emulation type for Console Redirection. Select VT100 to use the ASCII Character set. Select VT100+ to add color and function key support. Select ANSI to use the Extended ASCII Character Set. Select VT-UTF8 to use UTF8 encoding to map Unicode characters into one or more bytes. The options are VT100, **VT100+**, VT-UTF8, and ANSI.

Bits Per Second

Use this feature to set the transmission speed for a serial port used in Console Redirection. Make sure that the same speed is used in the host computer and the client computer. A lower transmission speed may be required for long and busy lines. The options are 9600, 19200, 38400, 57600, and **115200** (bits per second).

Data Bits

Use this feature to set the data transmission size for Console Redirection. The options are 7 and **8** (bits).

Parity

A parity bit can be sent along with regular data bits to detect data transmission errors. Select Even if the parity bit is set to 0, and the number of 1's in data bits is even. Select Odd if the parity bit is set to 0, and the number of 1's in data bits is odd. Select None if you do not want to send a parity bit with your data bits in transmission. Select Mark to add a mark as a parity bit to be sent along with the data bits. Select Space to add a Space as a parity bit to be sent with your data bits. The options are **None**, Even, Odd, Mark, and Space.

Stop Bits

A stop bit indicates the end of a serial data packet. Select 1 Stop Bit for standard serial data communication. Select 2 Stop Bits if slower devices are used. The options are **1** and 2.

Flow Control

Use this feature to set the flow control for Console Redirection to prevent data loss caused by buffer overflow. Send a "Stop" signal to stop sending data when the receiving buffer is full. Send a "Start" signal to start sending data when the receiving buffer is empty. The options are **None** and Hardware RTS/CTS.

VT-UTF8 Combo Key Support

Select Enabled to enable VT-UTF8 Combination Key support for ANSI/VT100 terminals. The options are Disabled and **Enabled**.

Recorder Mode

Select Enabled to capture the data displayed on a terminal and send it as text messages to a remote server. The options are **Disabled** and Enabled.

Resolution 100x31

Select Enabled for extended-terminal resolution support. The options are Disabled and **Enabled**.

Putty KeyPad

This feature selects Function Keys and KeyPad settings for Putty, which is a terminal emulator designed for the Windows OS. The options are **VT100**, LINUX, XTERMR6, SCO, ESCN, and VT400.

► Legacy Console Redirection Settings

Legacy Serial Redirection Port

Select a COM port to display redirection of legacy OS and legacy OPROM messages. The options are **COM1** and SOL/COM2.

Resolution

On legacy OS, the number of rows and columns supported redirection. The options are 80x24 and **80x25**.

Redirection After BIOS Post

When bootloader is selected, then legacy console redirection is disabled before booting to legacy OS. When always is select, then legacy console redirection is enabled for legacy OS. The options are **Always Enable** and BootLoader.

Serial Port for Out-of-Band Management / Windows Emergency Management Services (EMS)

The feature allows you to configure Console Redirection settings to support Out-of-Band Serial Port management.

Console Redirection EMS

Select Enabled to use the SOL port for Console Redirection. The options are **Disabled** and Enabled.

SATA Configuration Menu

SATA MODE

Use this feature to set the SATA mode. The options are RAID Mode, and **AHCI Mode**.

PCIe/PCI/PnP Configuration Menu

The following information is displayed:

- PCI Bus Driver Version

PCI Devices Common Settings:

Above 4G Decoding

This setting enables 64-bit PCI device access to memory beyond 4 GB for improved memory utilization and performance. The options are Disabled and **Enabled**.

Re-Size BAR Support

This setting enables or disables the Re-Size Base Address Register feature for compatible PCIe devices, which allows the system to allocate more memory to the device. The options are Disabled and **Enabled**.

SR-IOV Support

This setting enables or disables Single Root I/O Virtualization support for the system's PCIe devices. The options are Disabled and **Enabled**.

BME DMA Mitigation

This setting enables or disables Bus Mastering Error (BME) Direct Memory Access (DMA) mitigation for protection during the pre-boot process. The options are **Disabled** and Enabled.

ASPM Support

Configure the Active State Power Management (ASPM) level for PCIe links to optimize power consumption and performance. The options are **Disabled**, Auto, and Force L1.

Relaxed Ordering

This setting determines whether PCI Express devices are permitted to bypass strict transaction ordering, which can lead to potential performance improvements. The options are Disabled and **Enabled**.

No Snoop

This setting configures the No Snoop option for PCI Express devices, determining whether memory accesses bypass the cache. The options are Disabled and **Enabled**.

NVMe Firmware Source

This setting determines the source of firmware for NVMe devices, allowing you to select between native support or vendor-specific firmware. The options are **Vendor Defined Firmware** and AMI Native Support.

NVMe RAID Mode

Use this feature to enable or disable NVMe RAID mode. The options are **Disabled** and Enabled.

CBL-ASMC-1235DM5RYP35 SLOT1 PCI-e 5.0 X16 OPROM

Select EFI to allow you to boot the computer using the EFI device installed on the PCIe slot specified. The options are Disabled and **EFI**.

Onboard LAN1 Option ROM

Select which firmware function to be loaded for Onboard LAN1. The options are Disabled and **EFI**.

Onboard LAN1 Support

Use this feature to enable or disable the Onboard LAN1 Support. The options are **Enabled** and Disabled.

M.2-C PCI-e 5.0 x4 OPROM

Use this feature to enable or disable the M.2-C PCI-e 5.0 x4 OPROM option. The options are **EFI** and Disabled.

M.2-C PCI-e 5.0 x2 OPROM

Use this feature to enable or disable the M.2-C PCI-e 5.0 x2 OPROM option. The options are **EFI** and Disabled.

USB Configuration

The following information is displayed:

- USB Devices

XHCI Hand-off

This setting provides a workaround for operating systems that do not support XHCI hand-off. The XHCI ownership change must be claimed by the XHCI driver. The options are **Enabled** and Disabled.

Port 60/64 Emulation

Select Enabled for I/O port 60h/64h emulation support, which will provide complete legacy USB keyboard support for the operating systems that do not support legacy USB devices. The options are Disabled, Enabled, and **Auto**.

Network Configuration Menu

Network Stack

Select Enabled to enable Preboot Execution Environment (PXE) or Unified Extensible Firmware Interface (UEFI) for network stack support. The options are Disabled and **Enabled**.

IPv4 PXE Support (Available when "Network Stack" is set to Enabled)

Select Enabled to enable IPv4 PXE boot support. If this feature is disabled, it will not create the IPv4 PXE boot option. The options are Disabled and **Enabled**.

IPv4 HTTP Support (Available when "Network Stack" is set to Enabled)

Select Enabled to enable IPv4 HTTP boot support. If this feature is disabled, it will not create the IPv4 HTTP boot option. The options are Disabled and **Enabled**.

IPv6 PXE Support (Available when "Network Stack" is set to Enabled)

Select Enabled to enable IPv6 PXE boot support. If this feature is disabled, it will not create the IPv6 PXE boot option. The options are Disabled and **Enabled**.

IPv6 HTTP Support (Available when "Network Stack" is set to Enabled)

Select Enabled to enable IPv6 HTTP boot support. If this feature is disabled, it will not create the IPv6 HTTP boot option. The options are **Disabled** and Enabled.

PXE Boot Wait Time (Available when "Network Stack" is set to Enabled)

Use this feature to set the wait time (in seconds) upon which the system BIOS will wait for you to press the <ESC> key to abort PXE boot instead of proceeding with PXE boot by connecting to a network server immediately. Press the <+> or <-> key on your keyboard to change the value. The default value is **0**.

Media Detect Count (Available when "Network Stack" is set to Enabled)

Use this feature to set the wait time (in seconds) for the BIOS ROM to detect the presence of a LAN media either via the Internet connection or via a LAN port. Press the <+> or <-> key on your keyboard to change the value. The default value is **1**.

HTTP Boot Configuration Menu

HTTP Boot Configuration

HTTP Boot Policy

Use this feature to set the HTTP boot policy. The options are Apply to all LANs, **Apply to each LAN**, and Boot Priority #1 instantly.

HTTPS Boot Checks Hostname

Important: Disabling "HTTPS Boot Checks Hostname" is a violation of RFC 6125 and may expose you to Man-in-the-Middle Attacks. Supermicro is not responsible for any and all security risks incurred by you disabling this feature.

This setting determines whether HTTPS Boot verifies that the hostname in the server's TLS certificate matches the hostname of the remote server. The options are **Enabled** and Disabled (WARNING: Security Risk!!).

Priority of HTTP Boot

Instance of Priority 1: (Available when your motherboard supports this feature)

This feature sets the rank target port. The default setting is **1**.

Select IPv4 or IPv6

This feature specifies which connection the target LAN port should boot from. The options are **IPv4** and IPv6.

Boot Description

Use this feature to enter a boot description, which cannot be longer than 75 characters. Please be sure to enter a boot description; otherwise, the boot option for the URI cannot be created.

Boot URI

Enter a Boot Uniform Research Identifier (URI) with 128 characters or shorter. This Boot URI determines how IPv4 Boot Option and IPv6 Boot Option will be created. This feature is only supported on Dual or EFI Boot Mode.

Supermicro KMS Server Configuration Menu

► Supermicro KMS Server Configuration

Note: Be sure to configure all the features in the submenu of Supermicro KMS Server Configuration and the feature of "KMS Security Policy" in the submenu of Super-Guardians Configuration so that your system can communicate with the KMS server.

Supermicro KMS Server IP address

Use this feature to set the Supermicro Key Management Service (KMS) server IPv4 address in dotted-decimal notation.

Second Supermicro KMS Server IP address

Use this feature to set the second Supermicro KMS server IPv4 address in dotted-decimal notation.

Supermicro KMS TCP Port number

Use this feature to set the TCP port number used in Supermicro KMS Server. The valid range is 100–9999. The default setting is **5696**. Do not change the default setting unless a different TCP port number has been specified and used in the Supermicro KMS Server.

KMS Time Out

Use this feature to enter the KMS server connecting time-out (in seconds). The default setting is **5** (seconds).

TimeZone

Use this feature to set the correct time zone. The default setting is **0** (not specified).

Client UserName

Press <Enter> to set the client identity (UserName). The username can be between 0 and 63 characters in length.

Client Password

Press <Enter> to set the client identity (Password). The password can be between 0 and 31 characters in length.

KMS TLS Certificate/Size

This feature displays the Transport Layer Security (TLS) certificate and its size for CA Certificate, Client Certificate, and Client Private Key.

► CA Certificate

This setting provides options for managing the Certificate Authority (CA) certificate. The options are **Update**, Delete, and Export.

► Client Certificate

This setting provides options for managing the client certificate. The options are **Update**, Delete, and Export.

► Client Private Key

Use the three features to enroll factory defaults or load the KMS Transport Layer Security (TLS) certificates, which are generated by the KMS Server, from the file stored in the USB flash drive as shown below.

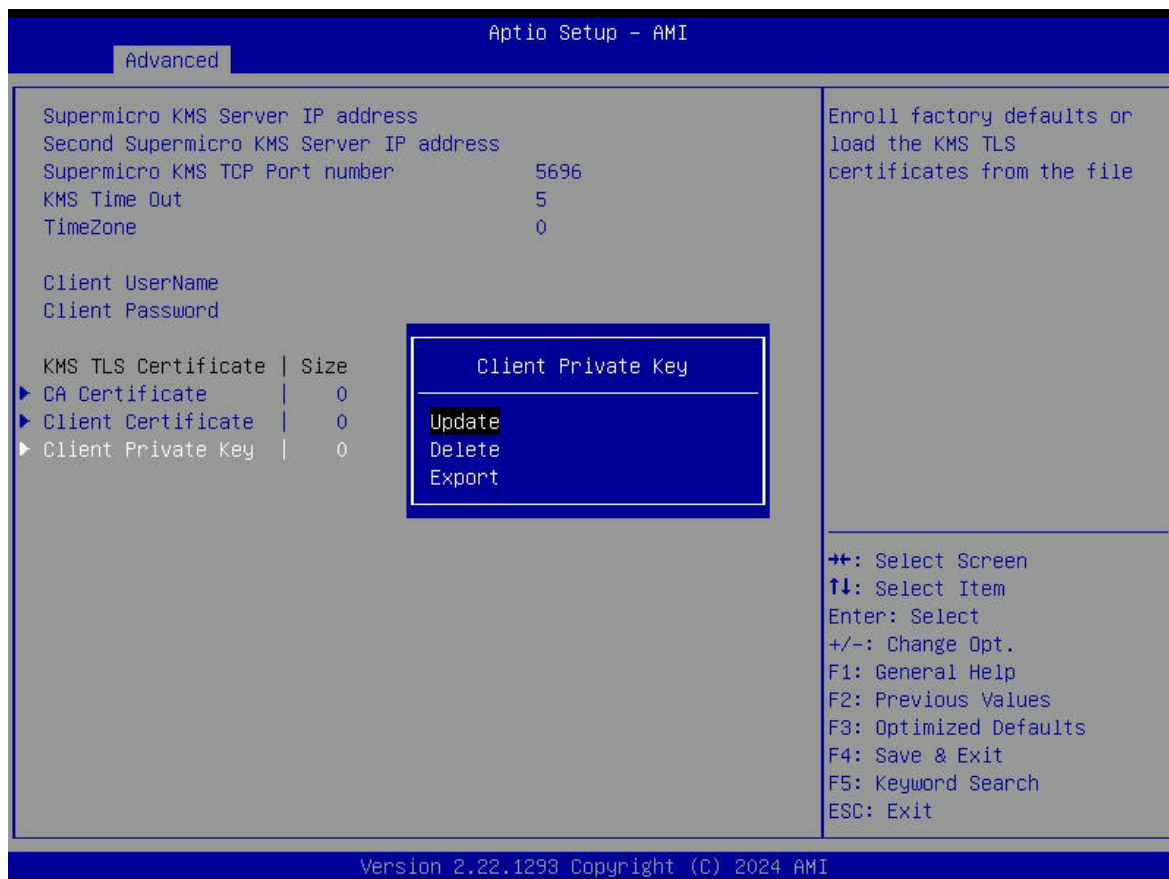

Private Key Password (Available when "Client Private Key" above has been set)

Use this feature to change the password for the client private key.

Super-Guardians Configuration Menu

▶ Super-Guardians Configuration

Super-Guardians Protection Policy

Use this feature to enable the Super-Guardians Protection Policy. The options are **Storage**, **System**, and **System and Storage**. Set this feature to **Storage** to protect and have secure access to Trusted Computing Group (TCG) NVMe devices with the Authentication-Key (AK). Set this feature to **System** to protect and have secure access to your system/motherboard with the AK. Set this feature to **System and Storage** to protect and have secure access to your system/motherboard/storage devices with the AK.

KMS Security Policy (Available when "TPM Security Policy" and "USB Security Policy" are set to Disabled)

Set this feature to **Enabled** to enable the KMS Security Policy. When this feature has not previously been set to **Enabled**, the options are **Disabled** and **Enabled**. Changes take effect after you save settings and reboot the system.

When this feature has previously been set to Enabled, the options are **Enabled**, Reset, and Key Rotation. Set this feature to Key Rotation to obtain an existing AK from the KMS server and create a new AK. To disable the KMS Security Policy, set this feature to Reset. When this feature is set to Reset, the system and TCG NVMe devices chosen in "Super-Guardians Protection Policy" will be in the unprotected mode.

Notes:

- Be sure that the KMS server is ready before configuring this feature.
- Use the professional KMS server solutions (e.g., Thales Server) or the Supermicro PyKMIP Software Package to establish the KMS server.

KMS Server Retry Count (Available when "TPM Security Policy" and "USB Security Policy" are set to Disabled)

Use this feature to specify how many times the system will attempt reconnecting to the KMS server. The valid range is 0–10. Press the <+> or <-> key on your keyboard to change the value. The default setting is 5. If the value is 0, the system will retry infinitely.

TPM Security Policy (Available when "KMS Security Policy" and "USB Security Policy" are set to Disabled)

Set this feature to Enabled to enable the TPM Security Policy. When this feature has not previously been set to Enabled, the options are **Disabled** and Enabled. Changes take effect after you save settings and reboot the system.

When this feature has previously been set to Enabled, the options are **Enabled** and Reset. To disable the TPM Security Policy, set this feature to Reset. When this feature is set to reset, the system and TCG NVMe devices chosen in "Super-Guardians Protection Policy" will be in the unprotected mode.

Note: Be sure to install a TPM 2.0 device to your system before configuring this feature.

TPM Security Policy (Available when "KMS Security Policy" and "USB Security Policy" are set to Disabled)

Set this feature to Enabled to enable the TPM Security Policy. When this feature has not previously been set to Enabled, the options are **Disabled** and Enabled. Changes take effect after you save settings and reboot the system.

When this feature has previously been set to Enabled, the options are Enabled and Reset. To disable the TPM Security Policy, set this feature to Reset. When this feature is set to reset, the system and TCG NVMe devices chosen in "Super-Guardians Protection Policy" will be in the unprotected mode.

Note: Be sure to install a TPM 2.0 device to your system before configuring this feature.

Load Authentication-Key (Available when "KMS Security Policy," "TPM Security Policy," and "USB Security Policy" are set to Disabled)

The options are **Disabled** and Enabled. Set this feature to Enabled. Changes take effect after you save settings and reboot the system. While booting, the BIOS will automatically load the Authentication-Key (filename: TPMAuth.bin) from the USB flash drive. Afterwards, the default setting will be set to Disabled by the BIOS.

Notes:

- Be sure to connect a USB flash drive with the Authentication-Key (filename: TPMAuth.bin) to your system before the system reboots.
- Be sure to save the Authentication-Key (filename: TPMAuth.bin) to the USB flash drive and have a backup. Please load the Authentication-Key (filename: TPMAuth.bin) after installing a TPM device. Otherwise, the TPM function can not work properly.

USB Security Policy (Available when "KMS Security Policy" and "TPM Security Policy" are set to Disabled)

Use this feature to enable the USB Security Policy. The options are **Disabled** and Enabled. Set this feature to Enabled. Changes take effect after you save settings and reboot the system. Connect a USB flash drive to your system before the system reboot. While booting, the BIOS will automatically create the USB Authentication-Key (filename: USBAuth.bin) and save it to the USB flash drive.

When this feature has been previously set to Enabled, the options are Enabled and Reset. To disable the USB Security Policy, set this feature to Reset. When this feature is set to Reset, the system and TCG NVMe devices chosen in "Super-Guardians Protection Policy" will be in the unprotected mode.

Note: Be sure to connect a USB flash drive to your system before configuring this feature. Save the USB Authentication-Key (filename: USBAuth.bin) to the USB flash drive and keep a backup.

TLS Authenticate Configuration Menu

► Server CA Configuration

This feature allows you to configure the client certificate that is to be used by the server.

▶ Enroll Certification

This feature allows you to enroll the certificate in the system.

▶ Enroll Certification Using File

This feature allows you to enroll the security certificate in the system by using a file.

Certification GUID

Press <Enter> and input the certification Global Unique Identifier (GUID).

▶ Commit Changes and Exit

Use this feature to save all changes and exit TLS settings.

▶ Discard Changes and Exit

Use this feature to discard all changes and exit TLS settings.

▶ Delete Certification

This feature is used to remove the selected TLS certificates that are no longer needed or valid.

▶ Client Certification Configuration

Use this feature to manage the TLS certificates used to authenticate remote clients connecting to your system. Add, view, or delete client certificates as needed.

▶ Enroll Certification

This feature allows you to enroll the certificate in the system.

▶ Enroll Certification Using File

This feature allows you to enroll the security certificate in the system by using a file.

Certification GUID

Press <Enter> and input the certification Global Unique Identifier (GUID).

▶ Commit Changes and Exit

Use this feature to save all changes and exit TLS settings.

▶ Discard Changes and Exit

Use this feature to discard all changes and exit TLS settings.

► Delete Certification

This feature is used to remove the selected TLS certificates that are no longer needed or valid.

Driver Health Menu

► Driver Health

This feature displays the health information of the drivers installed in your system, including LAN controllers, as detected by the BIOS. Select one and press <Enter> to see the details.

Note: This section is provided for reference only, for the driver health status will differ depending on the drivers installed in your system. It's also based on your system configuration and the environment that your system is operating in.

4.4 BMC

Use this menu to configure Baseboard Management Console (BMC) settings.



Figure 4-3. BMC Tab Screen

BMC Firmware Revision

This feature indicates the BMC firmware revision used in this system.

BMC STATUS

This feature indicates the status of the BMC firmware installed in this system.

System Event Log Menu

▶ System Event Log

Note: All values changed in this submenu do not take effect until computer is restarted.

SEL Components

Select Enabled to enable all system event logging upon system boot. The options are Disabled and **Enabled**.

Erasing Settings

Erase SEL (Available when "SEL Components" is set to Enabled)

Select (Yes, On next reset) to erase all system event logs upon next system boot. Select (Yes, On every reset) to erase all system event logs upon each system reboot. Select No to keep all system event logs after each system reboot. The options are **No**, (Yes, On next reset), and (Yes, On every reset).

When SEL is Full (Available when "SEL Components" is set to Enabled)

This feature defines what the BIOS should do when the system event log is full. Select Erase Immediately to erase all events in the log when the system event log is full. The options are **Do Nothing** and Erase Immediately.

BMC Network Configuration Menu

► BMC Network Configuration

Update BMC LAN Configuration

Select Yes for the BIOS to implement all IP/MAC address changes upon next system boot. The options are **No** and Yes.

Configure IPv4 Support

BMC LAN Selection

This feature displays the type of the BMC LAN.

BMC Network Link Status:

This feature displays the status of the BMC network link for this system.

Configuration Address Source (Available when "Update BMC LAN Configuration" is set to Yes)

Use this feature to select the source of the IPv4 connection. If Static is selected, note the IP address of the IPv4 connection and enter it to the system manually in the field. If DHCP is selected, the BIOS will search for a Dynamic Host Configuration Protocol (DHCP) server in the network that is attached to and request the next available IP address for this computer. The options are Static and **DHCP**.

Station IP Address

This feature displays the Station IP address in decimal and in dotted quad form (i.e., 172.29.176.131). It is available for configuration when "Configuration Address Source" above is set to Static.

Subnet Mask

This feature displays the sub-network that this computer belongs to. It is available for configuration when "Configuration Address Source" above is set to Static.

Station MAC Address

This feature displays the Station MAC address for this computer. MAC addresses are six two-digit hexadecimal numbers.

Gateway IP Address

This feature displays the Gateway IP address for this computer. This should be in decimal and in dotted quad form (i.e., 172.29.0.1). It is available for configuration when "Configuration Address Source" above is set to Static.

Configure IPv6 Support

IPv6 Address Status

This feature displays the status of the IPv6 address.

IPv6 Support (Available when "Update BMC LAN Configuration" is set to Yes)

Use this feature to enable IPv6 support. The options are **Enabled** and Disabled.

Configuration Address Source (Available when "IPv6 Support" is set to Enabled)

Use this feature to select the source of the IPv6 connection. If Static Configuration is selected, note the IP address of IPv6 connection and enter it to the system manually in the field. If the other two options are selected, the BIOS will search for a DHCP server in the network that is attached to and request the next available IP address for this computer. The options are Static Configuration, **DHCPv6 Stateless**, and DHCPv6 Stateful.

IPv6 Address ("Static," "DHCPv6 Stateless," or "DHCPv6 Stateful," depending on the option you selected for "Configuration Address Source" above)

This feature displays the station IPv6 address.

Prefix Length

This feature displays the prefix length. It is available for configuration when "Configuration Address Source" above is set to Static Configuration.

Gateway IP

This feature displays the IPv6 gateway IP address. It is available for configuration when "Configuration Address Source" above is set to Static Configuration.

Advanced Settings (Available when "Configuration Address Source" is set to DHCPv6 Stateless)

Use this feature to set the DNS server IP. The default setting allows this system to obtain the DNS server IP automatically. The options are **Auto obtain DNS server IP** and Manually obtain DNS server IP.

Preferred DNS server IP (Available when "Advanced Settings" above is set to Manually obtain DNS server IP)

This feature displays the preferred DNS server IP. It can be configured via Redfish.

Alternative DNS server IP (Available when "Advanced Settings" above is set to Manually obtain DNS server IP)

This feature displays the alternative DNS server IP. It can be configured via Redfish.

Configure VLAN Support

VLAN Support (Available when "Update BMC LAN Configuration" is set to Yes)

Use this feature to enable the virtual LAN (VLAN) support. The options are Enabled and Disabled.

VLAN ID (Available when "VLAN Support" is set to Enabled)

Use this feature to create a new VLAN ID. The valid range is 1–4094. The default setting is 1.

4.5 Security

This menu allows you to configure the following security settings for the system.

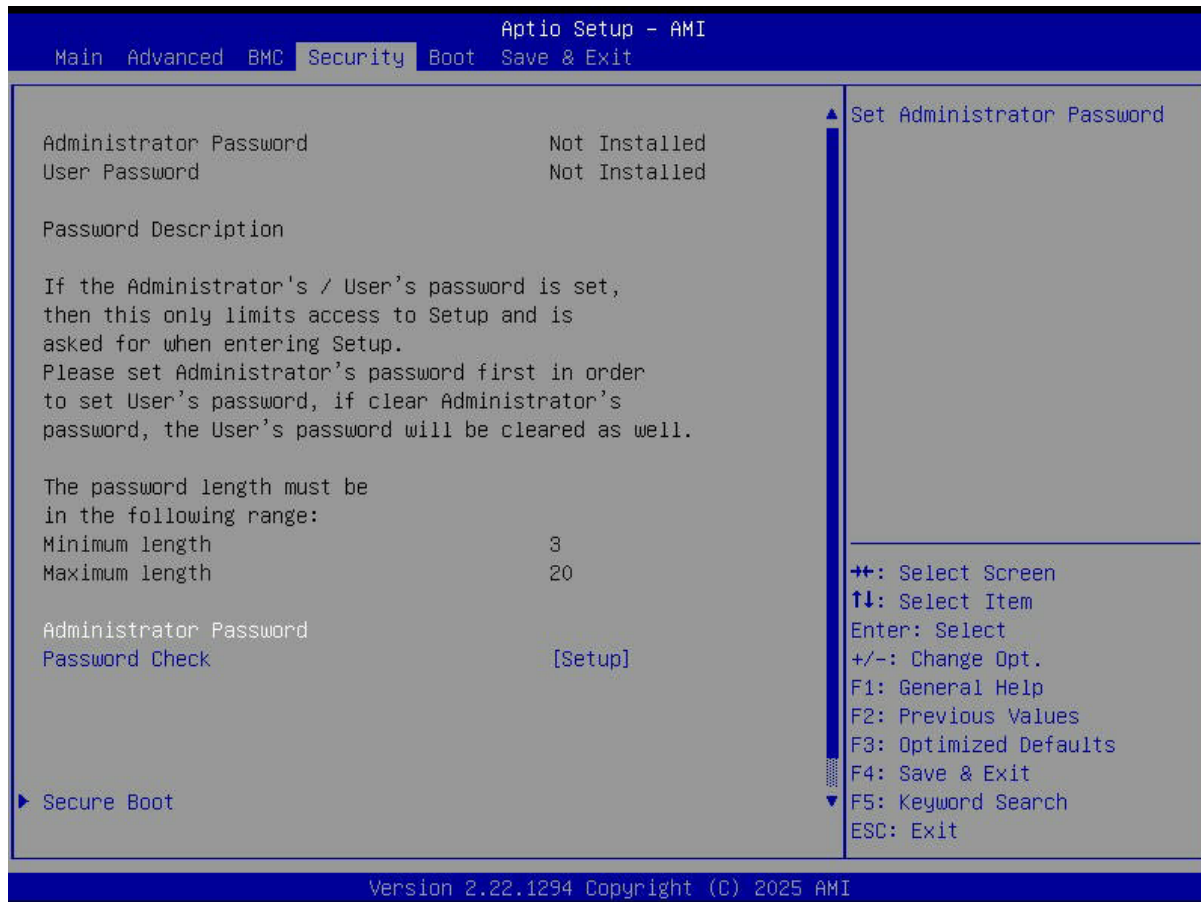

Figure 4-4. Security Tab Screen

Disable Block Sid and Freeze Lock (Available when your storage devices support TCG)

Select Enabled to allow SID authentication to be performed in TCG storage devices. The options are **Disabled** and Enabled.

The following information is displayed:

- Administrator Password
- User Password
- Password Description

Administrator Password

This feature indicates if an administrator password has been installed. Use this feature to set the administrator password, which is required to enter the BIOS Setup utility. The length of the password can be between three and 20 characters long.

User Password (Available when "Administrator Password" has been set)

This feature indicates if a user password has been installed. Use this feature to set the user password which is required to enter the BIOS Setup utility. The length of the password can be between three and 20 characters long.

Password Check

Select Setup for the system to check for a password upon entering the BIOS Setup utility. Select Always for the system to check for the passwords needed at bootup and upon entering the BIOS Setup utility. The options are **Setup** and Always.

► Secure Boot

The following information is displayed:

- System Mode
- Secure Boot

Note: For detailed instructions on configuring Security Boot settings, refer to the Security Boot Configuration User's Guide at <https://www.supermicro.com/support/manuals>.

Secure Boot

Select Enabled to configure Secure Boot settings. The options are **Disabled** and Enabled.

Secure Boot Mode

Use this feature to select the desired secure boot mode for the system. The options are Standard and **Custom**.

► Key Management

The following information is displayed:

- Vendor Keys

Note: This submenu is available when "Secure Boot Mode" is set to Custom.

Provision Factory Defaults

Select Enabled to install the default secure boot keys when the system is in the Setup Mode. Changes take effect after you save settings and reboot the system. The options are **Disabled** and Enabled.

► Restore Factory Keys

Select Yes to restore manufacturer default keys to ensure system security. The options are **Yes** and No. Selecting Yes will reset system to the User Mode.

Note: This submenu is available when any secure keys have been installed.

► Reset To Setup Mode

This feature resets the system to the Setup Mode. The options are **Yes** and No.

Note: This submenu is available when any secure keys have been installed.

► Enroll Efi Image

This feature allows the Efi image to run in the secure boot mode and enroll the SHA256 Hash certificate of a PE image into the Authorized Signature Database (DB).

► Export Secure Boot Variables

This feature exports the NVRAM contents of secure boot variables to a storage device. The options are **Yes** and No.

Note: This submenu is available when any secure keys have been installed.

Secure Boot variable / Size / Keys / Key Source

► Platform Key (PK)

Use this feature to enter and configure a set of values to be used as platform firmware keys for the system. These values also indicate the sizes, key numbers, and the sources of the authorized signatures. Select Update to update the platform key.

► Key Exchange Keys (KEK)

Use this feature to enter and configure a set of values to be used as Key Exchange Keys for the system. These values also indicate the sizes, key numbers, and the sources of the authorized signatures. Select Update to update the Key Exchange Keys. Select Append to append the Key Exchange Keys.

► Authorized Signatures (db)

Use this feature to enter and configure a set of values to be used as Authorized Signatures for the system. These values also indicate the sizes, key numbers, and sources of the authorized signatures. Select Update to update the Authorized Signatures. Select Append to append the new Authorized Signatures.

► Forbidden Signatures (dbx)

Use this feature to enter and configure a set of values to be used as Forbidden Signatures for the system. These values also indicate sizes, key numbers, and key sources of the forbidden signatures. Select Update to update the Forbidden Signatures. Select Append to append the Forbidden Signature.

► Authorized TimeStamps (dbt)

Use this feature to set and save the timestamps for the Authorized Signatures, which will indicate the time when these signatures are entered into the system. These values also indicate sizes, keys, and key sources of the authorized timestamps. Select Update to update the Authorized TimeStamps. Select Append to append the Authorized TimeStamps.

► OsRecovery Signatures (dbr)

Use this feature to set and save the Authorized Signatures used for OS recovery. Select Update to update the OsRecovery Signatures. These values also indicate sizes, keys, and key sources of the OsRecovery Signatures. Select Append to append the OsRecovery Signatures.

4.6 Boot

Use this menu to configure Boot settings.

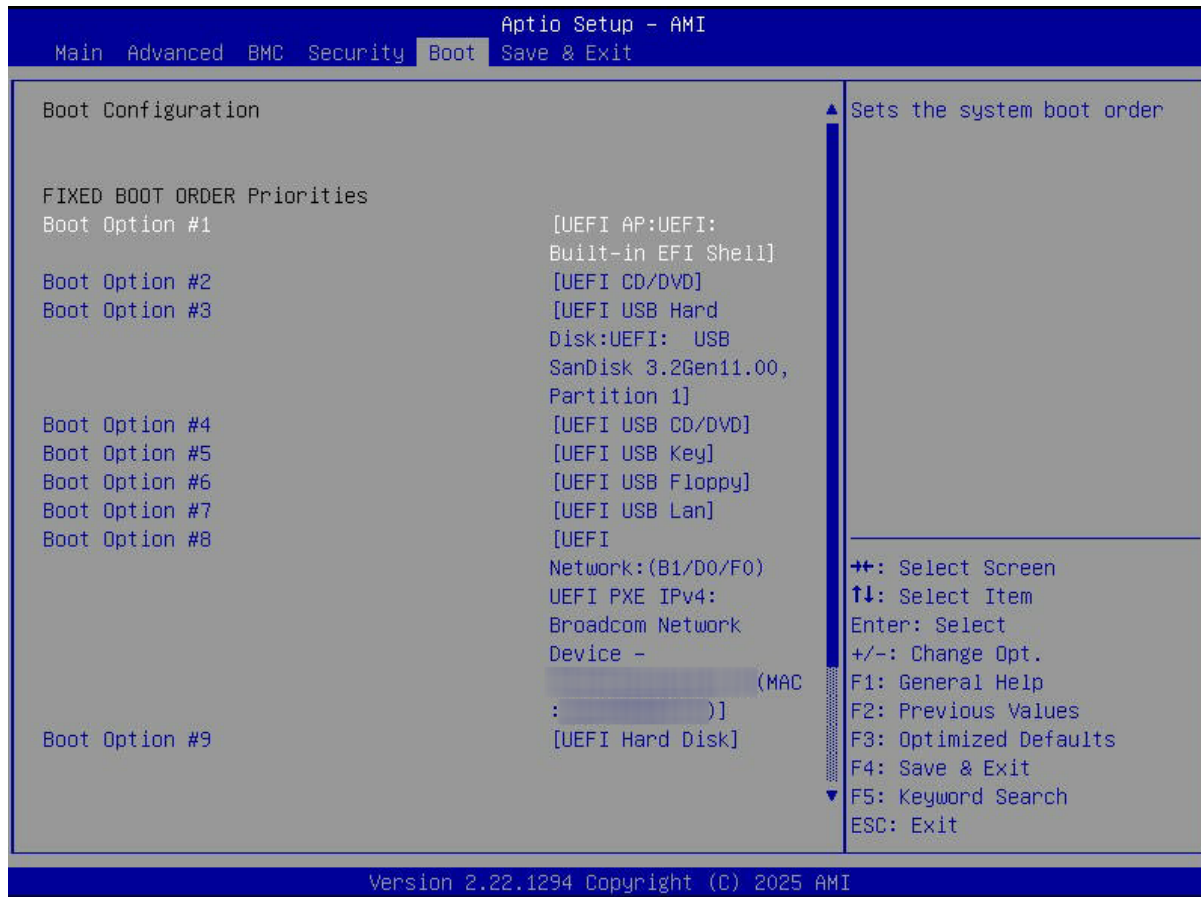

Figure 4-5. Boot Tab Screen

FIXED BOOT ORDER Priorities

Use this feature to prioritize the order of a bootable device from which the system will boot. Press <Enter> on each item sequentially to select the device.

- Boot Option #1 – Boot Option #9

► Add New Boot Option

Use this feature to add a new boot option to the boot priority features for system boot.

Note: This submenu is available when any storage device is detected by the BIOS.

Add boot option

Use this feature to specify the name for the new boot option.

Path for boot option

Use this feature to enter the path for the new boot option in the format fsx:\path\filename.efi.

Boot option File Path

Use this feature to specify the file path for the new boot option.

Create

After setting the name and the file path for the boot option, press <Enter> to create the new boot option in the boot priority list.

▶ Delete Boot Option

Use this feature to select a boot device to delete from the boot priority list.

Delete Boot Option

Use this feature to remove an EFI boot option from the boot priority list.

▶ UEFI NETWORK Drive BBS Priorities

Use this feature to set the system boot order of detected devices.

▶ UEFI Application Boot Priorities

Use this feature to set the system boot order of detected devices.

▶ UEFI USB Key Drive BBS Priorities

Use this feature to set the system boot order of detected devices.

▶ UEFI Hard Disk Drive BBS Priorities

Use this feature to set the system boot order of detected devices.

4.7 Save & Exit

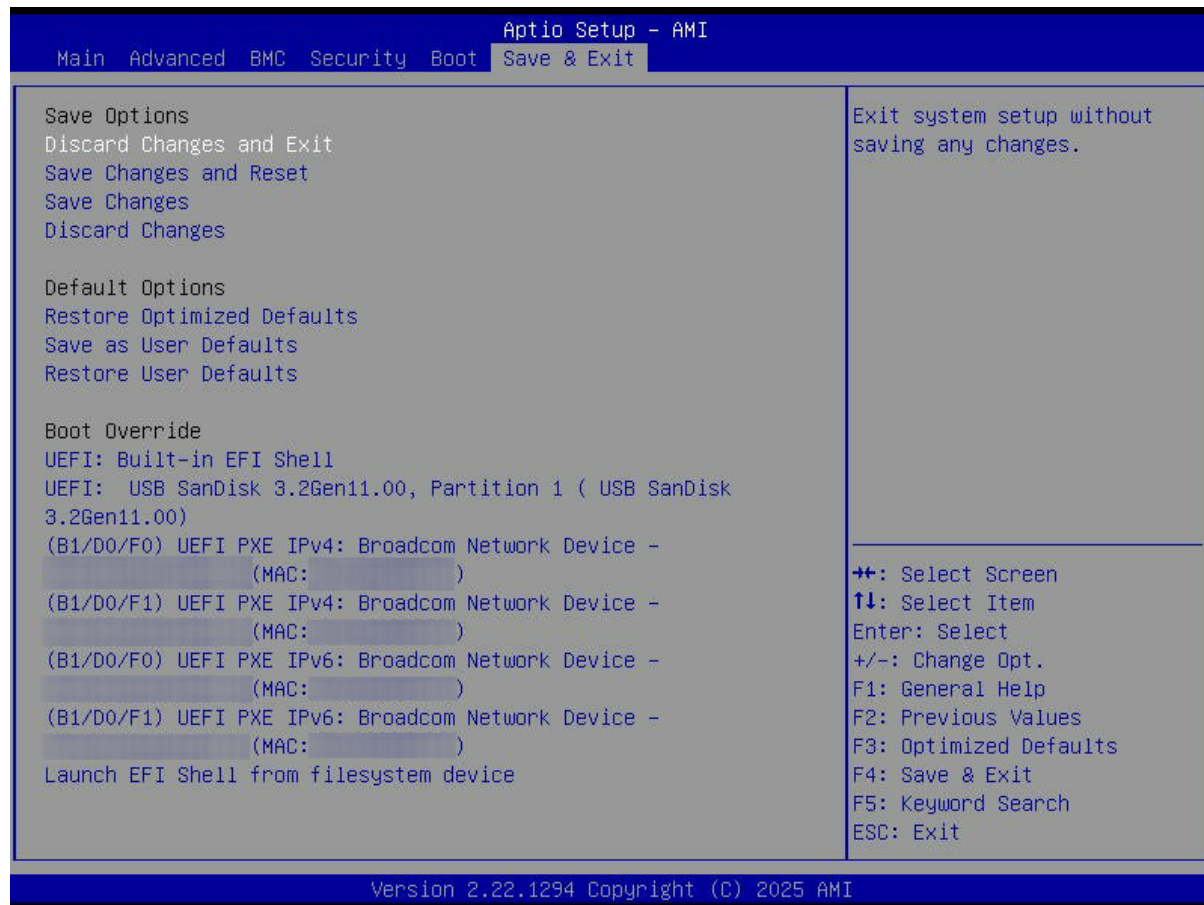

Figure 4-6. Save & Exit Tab

Save Options

Discard Changes and Exit

Use this feature to exit from the BIOS Setup utility without making any permanent changes to the system configuration and reboot the computer.

Save Changes and Reset

On completing the system configuration changes, use this feature to exit the BIOS Setup utility and reboot the computer for the new system configuration parameters to take effect.

Save Changes

On completing the system configuration changes, use this feature to save all changes made. This will not reset (reboot) the system.

Discard Changes

Select this feature and press <Enter> to discard all changes made and return to the BIOS Setup utility.

Default Options**Restore Optimized Defaults**

Select this feature and press <Enter> to load manufacturer optimized default settings, which are intended for maximum system performance but not for maximum stability.

Note: After pressing <Enter>, reboot the system for the changes to take effect, which ensures that this system has the optimized default settings.

Save as User Defaults

Select this feature and press <Enter> to save all changes as the default values specified to the BIOS Setup utility for future use.

Restore User Defaults

Select this feature and press <Enter> to retrieve user-defined default settings that have been saved previously.

Boot Override

Note: Use this section to override the Boot priorities sequence in the Boot menu, and immediately boot the system with a device specified here instead of the one specified in the boot list. This is a one-time boot override.

Appendix 5:

Software

After the BH4SRG motherboard has been installed, you can install the Operating System (OS), configure RAID settings, and install the drivers.

Microsoft Windows OS Installation

If you will be using RAID, you must configure RAID settings before installing the Windows OS and the RAID driver. Refer to the RAID Configuration User Guides posted on our website at <https://www.supermicro.com/support/manuals>.

Installing the OS

1. Create a method to access the Microsoft Windows installation ISO file. That can be a USB flash or media drive, or the BMC KVM console.
2. Retrieve the proper drivers. Go to the Supermicro web page for your motherboard and click on "Download the Latest Drivers and Utilities," select the proper driver, and copy it to a USB flash drive.
3. Boot from a bootable device with Windows OS installation. You can see a bootable device list by pressing <F11> during the system bootup.

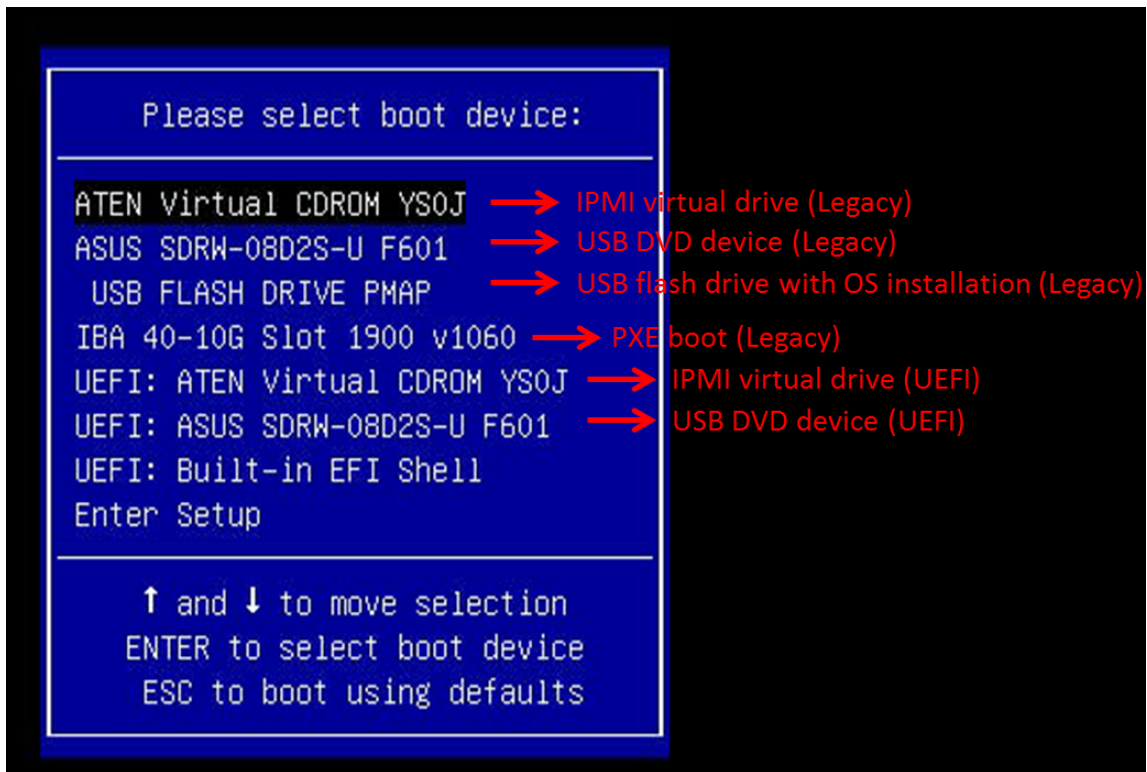

Figure 5-1. Selecting the Boot Device

4. During Windows Setup, continue to the dialog box where you select the drives on which to install Windows. If the disk you want to use is not listed, click on the “Load driver” link at the bottom left corner.

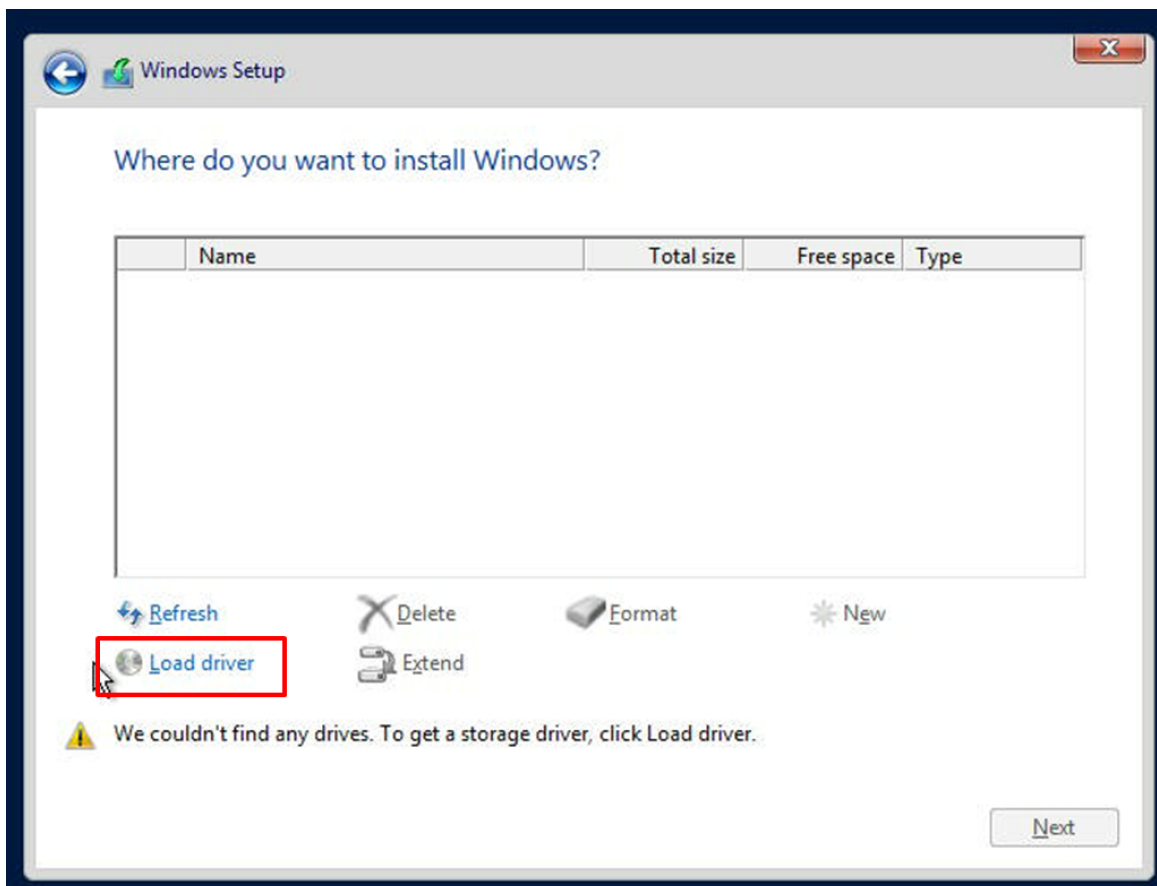

Figure 5-2. Loading the Driver Link

To load the driver, browse the USB flash drive for the proper driver files.

5. Once all devices are specified, continue with the installation.
6. After the Windows OS installation has completed, the system will automatically reboot multiple times for system updates.

Driver Installation

The Supermicro website contains drivers and utilities for your system at the following page:

<https://www.supermicro.com/wdl>.

Some of these drivers and utilities must be installed, such as the chipset driver. After accessing the website, go into the CDR_Images (in the parent directory of the above link) and locate the ISO file for your motherboard. Download this file to a USB flash or media drive. You may also use a utility to extract the ISO file if preferred.

Another option is to go to the Supermicro website at <https://www.supermicro.com>. Find the product page for your motherboard and download the latest drivers and utilities. Insert the flash drive or disk, and the screenshot shown below should appear.

Note: Click the icons showing a hand writing on paper to view the readme files for each item. Click the computer icons to the right of these items to install each item (from top to bottom) one at a time. After installing each item, you must reboot the system before moving on to the next item on the list. The bottom icon with a CD on it allows you to view the entire contents.

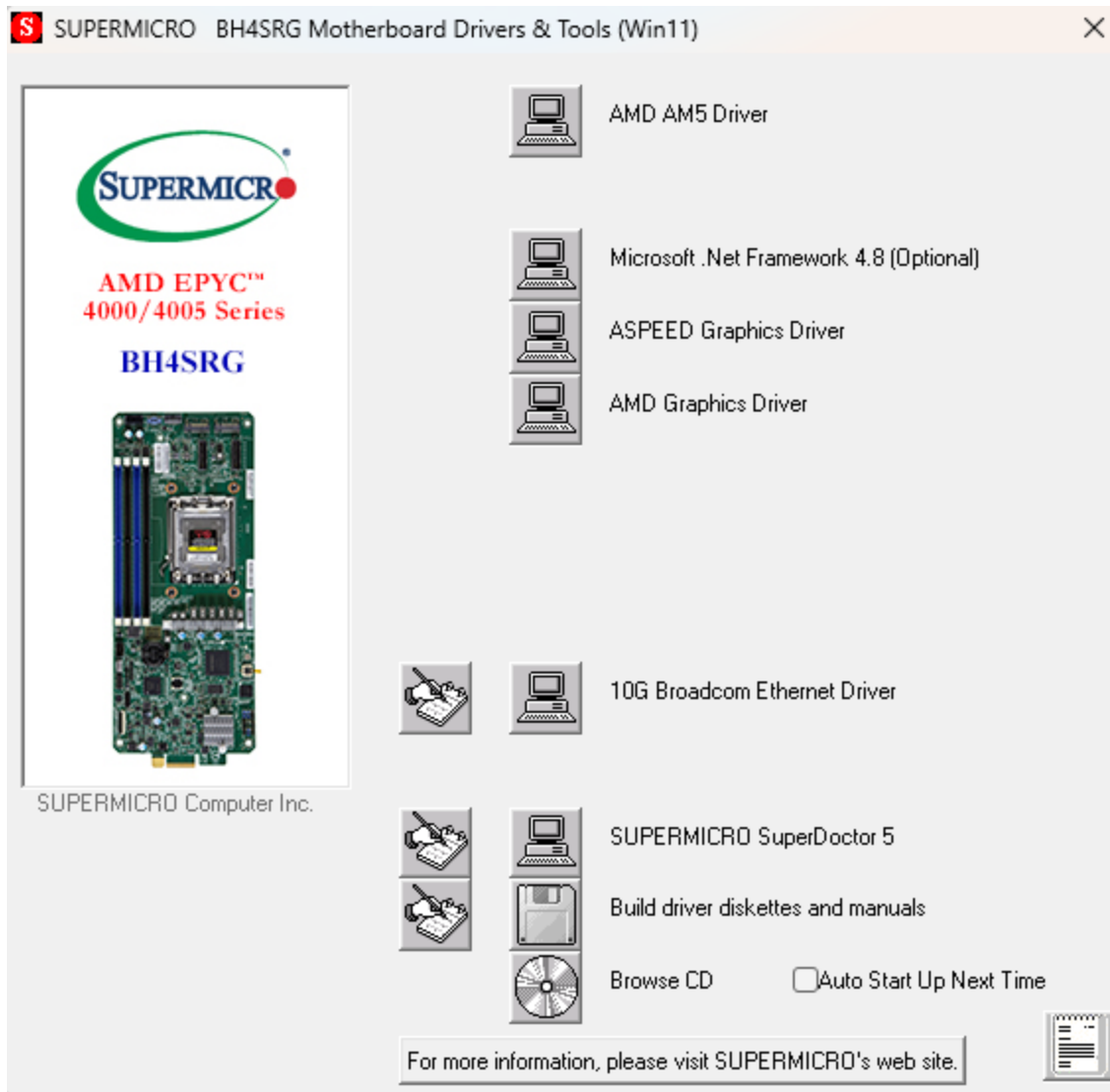

Figure 5-3. Drivers & Tools Screen

BMC

The BH4SRG motherboard provides remote access, monitoring, and management through the baseboard management controller (BMC) and other management controllers distributed among different system modules. There are several BIOS settings that are related to BMC. For general documentation and information on BMC, visit our website at the following page:

<https://www.supermicro.com/en/solutions/management-software/bmc-resources>

BMC ADMIN User Password

For security, each system is assigned a unique default BMC password for the ADMIN user. The password can be found on a sticker on the motherboard and a sticker on the chassis, for Supermicro chassis. The sticker also displays the BMC MAC address. If necessary, the password can be reset using the Supermicro IPMICFG tool.



Figure 5-4. BMC Password Label

Appendix 6:

Standardized Warning Statements

The following statements are industry standard warnings, provided to warn the user of situations which have the potential for bodily injury. Should you have questions or experience difficulty, contact Supermicro's Technical Support department for assistance. Only certified technicians should attempt to install or configure components.

Read this section in its entirety before installing or configuring components in the Supermicro BH4SRG motherboard.

These warnings may also be found on our website at the following page:

https://www.supermicro.com/about/policies/safety_information.cfm

Battery Handling



CAUTION There is risk of explosion if the battery is replaced by an incorrect type. Replace the battery only with the same or equivalent type recommended by the manufacturer. Dispose of used batteries according to the manufacturer's instructions.

警告!

バッテリーを間違ったタイプに交換すると爆発の危険があります。交換する電池はメーカーが推奨する型、または同等のものを使用下さい。使用済電池は製造元の指示に従って処分して下さい。

警告!

如果更换的电池类型不正确。请只使用同类电池或制造商推荐的功能相当的电池更换原有电池。请按制造商的说明处理废旧电池。

警告!

如果更換的電池類型不正確。請使用製造商建議之相同或功能相當的電池更換原有電池。請按照製造商的說明指示處理廢棄舊電池。

WARNUNG!

Es besteht Explosionsgefahr, wenn die Batterie durch einen falschen Typ ersetzt wird. Ersetzen Sie die Batterie nur durch den gleichen oder vom Hersteller empfohlenen Batterietyp. Entsorgen Sie die benutzten Batterien nach den Anweisungen des Herstellers.

¡ADVERTENCIA!

Existe riesgo de explosión si la batería se reemplaza por un tipo incorrecto. Reemplazar la batería exclusivamente con el mismo tipo o el equivalente recomendado por el fabricante. Desechar las baterías gastadas según las instrucciones del fabricante.

ATTENTION!

Il existe un risque d'explosion si la batterie est remplacée par un type incorrect. Ne la remplacer que par une pile de type semblable ou équivalent, recommandée par le fabricant. Jeter les piles usagées conformément aux instructions du fabricant.

אזהרה!

קיימת סכנת פיצוץ אם הסוללה תוחלף בסוג שגוי. יש להחליף את הסוללה בסוג התואם מחברת יצרן מומלצת. סילוק הסוללות המשומשות יש לבצע לפי הוראות היצרן.

تحذير!

هناك خطر الانفجار إذا تم استبدال البطارية بنوع غير صحيح
اسحبذال البطارية
فقط بنفس النوع أو ما يعادلها مما أوصت به الشركة المصنعة
جخلص من البطاريات المسحمة وفقاً لعليمات الشركة الصانعة

경고!

배터리를 잘못된 종류로 교체하면 폭발의 위험이 있습니다. 기존 배터리와 동일하거나 제조사에서 권장하는 동등한 종류의 배터리로만 교체해야 합니다. 제조사의 안내에 따라 사용된 배터리를 처리하여 주십시오.

WAARSCHUWING!

Er bestaat explosiegevaar als de batterij wordt vervangen door een verkeerd type. Vervang de batterij slechts met hetzelfde of een equivalent type die door de fabrikant aanbevolen wordt. Gebruikte batterijen dienen overeenkomstig fabrieksvoorschriften afgevoerd te worden.

Product Disposal

Warning! Ultimate disposal of this product should be handled according to all national laws and regulations.

警告!

この製品を廃棄処分する場合、国の関係する全ての法律・条例に従い処理する必要があります。

警告!

本产品的废弃处理应根据所有国家的法律和规章进行。

警告!

本產品的廢棄處理應根據所有國家的法律和規章進行。

Warnung!

Die Entsorgung dieses Produkts sollte gemäß allen Bestimmungen und Gesetzen des Landes erfolgen.

¡Advertencia!

Al deshacerse por completo de este producto debe seguir todas las leyes y reglamentos nacionales.

Attention!

La mise au rebut ou le recyclage de ce produit sont généralement soumis à des lois et/ou directives de respect de l'environnement. Renseignez-vous auprès de l'organisme compétent.

אזהרה!

סילוק סופי של מוצר זה חייב להיות בהתאם להנחיות וחוקי המדינה.

تحذير!

عند التخلص النهائي من هذا المنتج ينبغي التعامل معه وفقا لجميع القوانين والأنظمة الوطنية

경고!

이 제품은 해당 국가의 관련 법규 및 규정에 따라 폐기되어야 합니다.

Waarschuwing!

De uiteindelijke verwijdering van dit product dient te geschieden in overeenstemming met alle nationale wetten en reglementen.